

# 2557

## PROTECTED QUAD LOW-SIDE DRIVER WITH FAULT DETECTION & SLEEP MODE

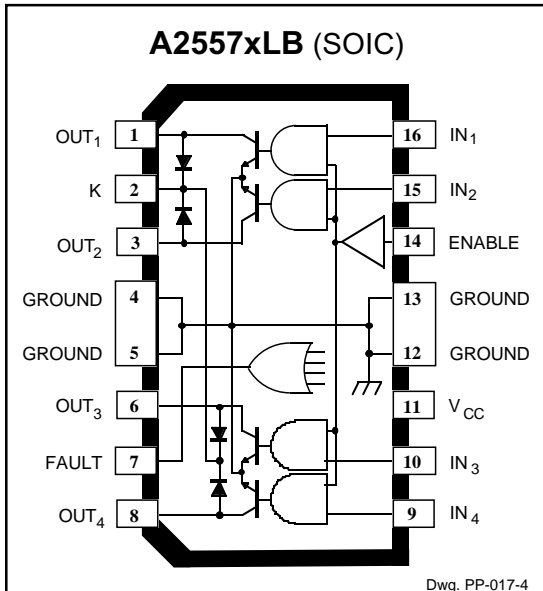

Note that the A2557xB (DIP) and the A2557xLB (SOIC) are electrically identical and share a common terminal number assignment.

### ABSOLUTE MAXIMUM RATINGS

Output Voltage, $V_O$ .....	60 V
Over-Current Protected Output Voltage, $V_{OCP}$ .....	32 V
Output Current, $I_O$ .....	500 mA*
FAULT Output Voltage, $V_{FLT}$ .....	60 V
Logic Supply Voltage, $V_{CC}$ .....	7.0 V
Input Voltage, $V_I$ or $V_{OE}$ .....	7.0 V
Package Power Dissipation, $P_D$ .....	See Graph
Operating Temperature Range, $T_A$	
Suffix 'S-' .....	-20°C to +85°C
Suffix 'E-' .....	-40°C to +85°C
Suffix 'K-' .....	-40°C to +125°C
Junction Temperature, $T_J$ .....	+150°C*
Storage Temperature Range, $T_S$ .....	-55°C to +150°C

\*Outputs are current limited at approximately 500 mA per driver and junction temperature limited if higher current is attempted.

The A2557xB, A2557xEB, and A2557xLB have been specifically designed to provide cost-effective solutions to relay-driving applications with up to 300 mA drive current per channel. They may also be used for driving incandescent lamps in applications where turn-on time is not a concern. Each of the four outputs will sink 300 mA in the on state. The outputs have a minimum breakdown voltage of 60 V and a sustaining voltage of 40 V. A low-power Sleep Mode is activated with either ENABLE low or all inputs low. In this mode, the supply current drops to below 100  $\mu$ A.

Over-current protection for each channel has been designed into these devices and is activated at a nominal 500 mA. It protects each output from short circuits with supply voltages up to 32 V. When an output experiences a short circuit, the output current is limited at the 500 mA current clamp. In addition, foldback circuitry decreases the current limit if an excessive voltage is present across the output and assists in keeping the device within its SOA (safe operating area). An exclusive-OR circuit compares the input and output state of each driver. If either a short or open load condition is detected, a single FAULT output is turned on (active low). Similar devices, for operation to 1.3 A, are available as the UDx2547B/EB.

Continuous or multiple overload conditions causing the channel temperature to reach approximately 165°C will result in an additional linear decrease in the output current of the affected driver. If the fault condition is corrected, the output stage will return to its normal saturated condition.

The first character of the part number suffix determines the device operating temperature range. Suffix 'S-' is the standard -20°C to +85°C; suffix 'E-' is -40°C to +85°C; suffix 'K-' is for the industrial temperature range of -40°C to +125°C. Package suffix '-B' devices are 16-pin power DIPs; suffix '-EB' devices are 28-lead power PLCCs; and suffix '-LB' are 16-lead power wide-body SOICs for surface-mount applications. All packages are of batwing construction to provide for maximum package power dissipation.

### FEATURES

- 300 mA Output Current per Channel
- Independent Over-Current Protection & Thermal Limiting for Each Driver
- Output Voltage to 60 V
- Output SOA Protection
- Fault-Detection Circuitry for Open or Shorted Load
- Low Quiescent Current Sleep Mode
- Integral Output Flyback/Clamp Diodes
- TTL- and 5 V CMOS-Compatible Inputs

Complete part number includes a suffix to identify operating temperature range (E-, K-, or S-) and package type (-B, -EB, or -LB). Always order by complete part number, e.g., **A2557KLB**.



**2557**  
**PROTECTED QUAD DRIVER**  
**WITH FAULT DETECTION**  
**& SLEEP MODE**

**ELECTRICAL CHARACTERISTICS** over operating temperature range,  $V_{CC} = 4.75\text{ V}$  to  $5.25\text{ V}$

Characteristic	Symbol	Test Conditions	Limits			
			Min.	Typ.	Max.	Units
Output Leakage Current*	$I_{CEX}$	$V_O = 60\text{ V}, V_I = 0.8\text{ V}, V_{OE} = 2.0\text{ V}$	—	30	100	$\mu\text{A}$
		$V_O = 60\text{ V}, V_I = 2.0\text{ V}, V_{OE} = 0.8\text{ V}$	—	<1.0	100	$\mu\text{A}$
Output Sustaining Voltage	$V_{O(SUS)}$	$I_O = 100\text{ mA}, V_I = V_{OE} = 0.8\text{ V}, V_{CC} = \text{Open}$	40	—	—	V
Output Saturation Voltage	$V_{O(SAT)}$	$I_O = 100\text{ mA}$	—	65	200	mV
		$I_O = 300\text{ mA}$	—	180	300	mV
Over-Current Limit	$I_{OM}$	5 ms PulseTest, $V_O = 5.0\text{ V}$	—	500	—	mA
Input Voltage	$V_{IH}$	$IN_n$ or ENABLE	2.0	—	—	V
	$V_{IL}$	$IN_n$ or ENABLE	—	—	0.8	V
Input Current	$I_{IH}$	$IN_n$ or ENABLE, $V_{IH} = 2.0\text{ V}$	—	—	10	$\mu\text{A}$
	$I_{IL}$	$IN_n$ or ENABLE, $V_{IL} = 0.8\text{ V}$	—	—	-10	$\mu\text{A}$
Fault Output Leakage Current	$I_{FLT}$	$V_{FLT} = 60\text{ V}$	—	4.0	15	$\mu\text{A}$
		$V_{FLT} = 5\text{ V}$	—	<1.0	2.0	$\mu\text{A}$
Fault Output Current	$I_{FLT}$	$V_{FLT} = 5\text{ V}$ , Driver Output Open, $V_I = 0.8\text{ V}, V_{OE} = 2.0\text{ V}$	40	60	80	$\mu\text{A}$
Fault Output Saturation Voltage	$V_{FLT(SAT)}$	$I_{FLT} = 30\text{ }\mu\text{A}$	—	0.1	0.4	V
Clamp Diode Forward Voltage	$V_F$	$I_F = 500\text{ mA}$	—	1.2	1.7	V
		$I_F = 750\text{ mA}$	—	1.5	2.1	V
Clamp Diode Leakage Current	$I_R$	$V_R = 60\text{ V}$	—	—	50	$\mu\text{A}$
Turn-On Delay	$t_{PHL}$	$I_O = 300\text{ mA}, 50\% V_I$ to $50\% V_O$	—	0.6	10	$\mu\text{s}$
		From Sleep, $I_O = 300\text{ mA}, 50\% V_I$ to $50\% V_O$	—	3.0	—	$\mu\text{s}$
		$I_O = 300\text{ mA}, 50\% V_{OE}$ to $50\% V_O$	—	1.3	10	$\mu\text{s}$
Turn-Off Delay	$t_{PLH}$	$I_O = 300\text{ mA}, 50\% V_I$ to $50\% V_O$	—	2.0	10	$\mu\text{s}$
		$I_O = 300\text{ mA}, 50\% V_{OE}$ to $50\% V_O$	—	1.4	10	$\mu\text{s}$
Total Supply Current	$I_{CC}$	All Outputs Off	—	0.075	0.1	mA
		Any One Output On	—	12	20	mA
		Two Outputs On	—	18	30	mA
		Three Outputs On	—	24	40	mA
		All Outputs On	—	30	50	mA
Thermal Limit	$T_J$		—	165	—	$^{\circ}\text{C}$

Typical Data is at  $T_A = +25^{\circ}\text{C}$  and  $V_{CC} = 5\text{ V}$  and is for design information only.

Negative current is defined as coming out of (sourcing) the specified terminal.

As used here, -100 is defined as greater than +10 (absolute magnitude convention) and the minimum is implicitly zero.

\* Measurement includes output fault-sensing pull-down current.

# 2557 PROTECTED QUAD DRIVER WITH FAULT DETECTION & SLEEP MODE

## TYPICAL OPERATING CHARACTERISTICS

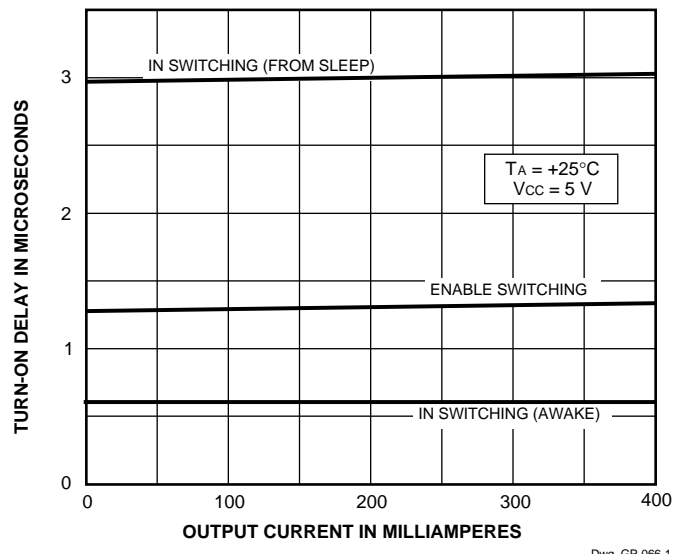
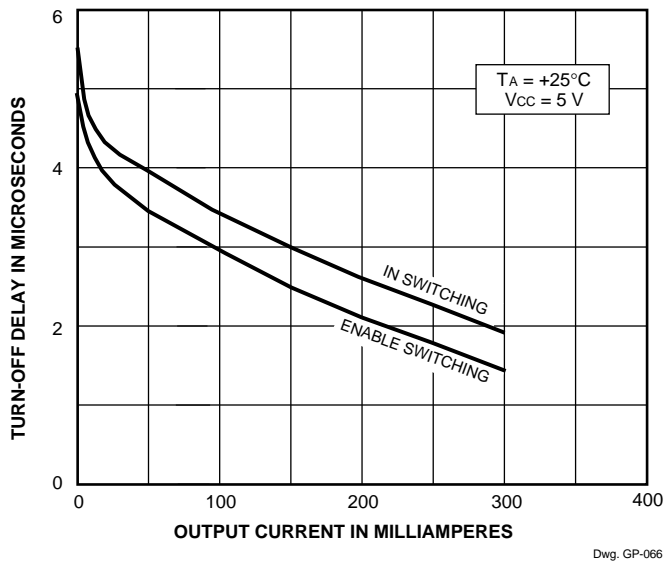
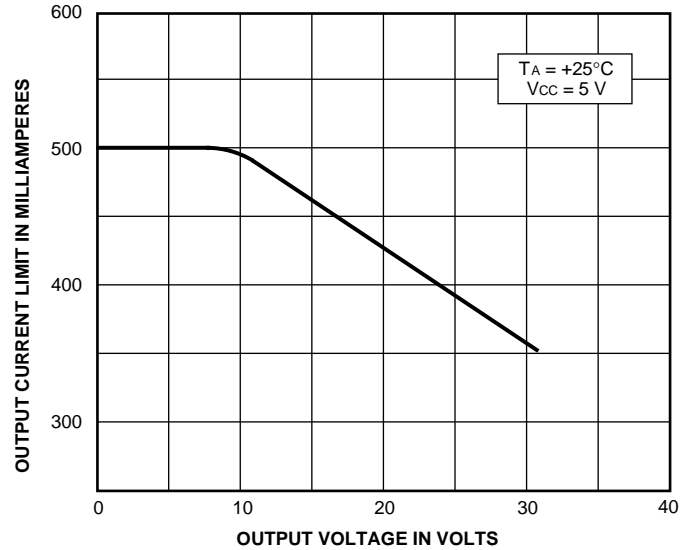
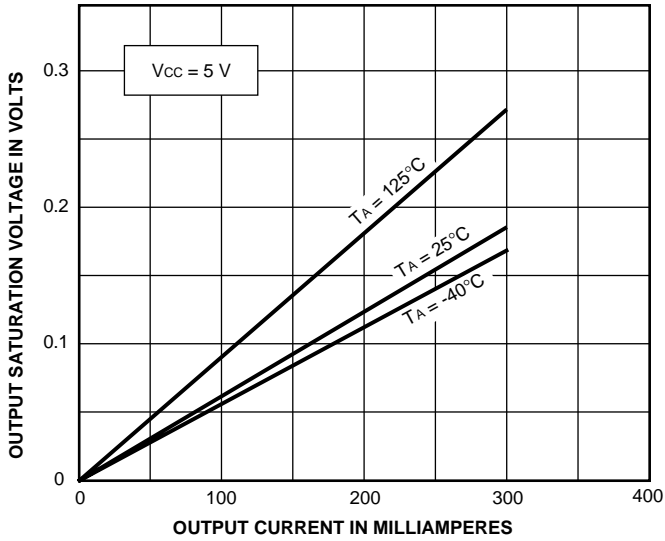

# 2557 PROTECTED QUAD DRIVER WITH FAULT DETECTION & SLEEP MODE

## CIRCUIT DESCRIPTION AND APPLICATION

The A2557 low-current quad power drivers provide the same protected output driver function as (and are pin compatible with) the UDx2543/49/59 devices, combined with a fault diagnostic scheme similar to the UDx2547, plus an automatic low-current Sleep-Mode function. These devices monitor their outputs for fault (open or shorted) conditions. For each channel the input and output levels are compared. If these are different from the expected levels then a fault condition is flagged by pulling the common FAULT output low.

Status	IN <sub>N</sub>	ENABLE	OUT <sub>N</sub>	FAULT
Normal Load	H	H	L	H
	L	H	H	H
Sleep Mode	X	L	H	H
	All L	X	H	H
Over-Current or Short to Supply	H	H	R	L
Open Load or Short to Ground	L	H	L	L
Thermal Fault	H	H	H	L

R = Linear drive, current limited.

The FAULT output is operational only if ENABLE is high. The output state is detected by monitoring the OUT<sub>n</sub> terminal using a comparator whose threshold is typically 2.5 V. In order to detect open-circuit outputs, a 30 μA current sink pulls the output below the comparator threshold. To ensure correct fault operation, a minimum load of approximately 1 mA is required. The fault function is disabled when in 'sleep' mode, i.e., FAULT goes high and the 30 μA output sinks are turned off. The FAULT output is a switched current sink of typically 60 μA.

Each channel consists of a TTL/CMOS-compatible logic input gated with a common ENABLE input. A logic high at the input will provide drive to turn on the output npn switch. Each output has a current-limit circuit that limits the output current by detecting the voltage drop across a low-value internal resistor in the emitter of the output switch. If this drop reaches a threshold, then the base drive to the output switch is reduced to maintain constant current in the output.

To keep the device within its safe operating area (SOA) this output current limit is further reduced

- if the power dissipation in the output device increases the local junction temperature above 165°C (nominal), so as to limit the power dissipation (and hence the local junction temperature). As each channel has its own thermal limit circuitry this provides some independence between the output channels, i.e., one channel can be operating in thermally reduced current limit, while the others can provide full drive capability.
- as a function of the output voltage. Full current limit of 500 mA (nominal) is available up to approximately V<sub>O</sub> = 8 V; above this the limit is reduced linearly to about 350 mA at V<sub>O</sub> = 32 V. This helps to improve SOA by immediately reducing the peak power pulse into a shorted load at high V<sub>O</sub>.

A logic low at the ENABLE input causes all outputs to be switched off regardless of the state of the IN terminals. In addition, the device is put into a low quiescent current 'sleep' mode, reducing I<sub>CC</sub> below 100 μA. If ENABLE is taken high and any of the inputs go high, the circuit will 'auto-wake-up'. However, if the device is enabled, but all inputs stay low, then the circuit remains in 'sleep' mode.

All outputs have internal flyback diodes, with a common-cathode connection at the K terminal.

### Incandescent lamp driver

High incandescent lamp turn-on (in-rush currents) can contribute to poor lamp reliability and destroy semiconductor lamp drivers. When an incandescent lamp is initially turned on, the cold filament is at minimum resistance and would normally allow a 10x to 12x in-rush current.

Warming (parallel) or current-limiting (series) resistors protect both driver and lamp but use significant power either when the lamp is off or when the lamp is on, respectively. Lamps with steady-state current ratings up to 300 mA can be driven without the need for warming or current-limiting resistors, if lamp turn-on time is not a concern (10s of ms).

With these drivers, during turn-on, the high in-rush current is sensed by the internal sense resistor, drive current to the output stage is reduced, and the output operates in a linear mode with the load current limited to approximately 500 mA. During lamp warmup, the filament resistance increases to its maximum value, the output driver goes into saturation and applies maximum rated voltage to the lamp.

# 2557 PROTECTED QUAD DRIVER WITH FAULT DETECTION & SLEEP MODE

## CIRCUIT DESCRIPTION AND APPLICATION (continued)

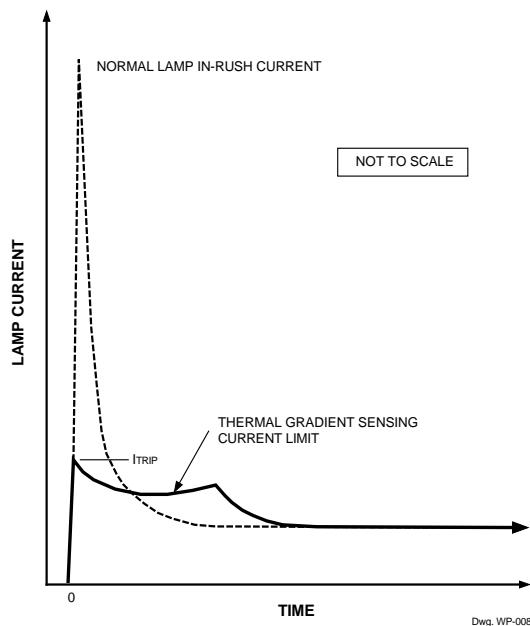

### Inductive load driver

Bifilar (unipolar) stepper motors (and other inductive loads) can be driven directly. The internal diodes prevent damage to the output transistors by suppressing the high-voltage spikes that occur when turning off an inductive load. For rapid current decay (fast turn-off speeds), the use of Zener diodes will raise the flyback voltage and improve performance. However, the peak voltage must not exceed the specified minimum sustaining voltage ( $V_{\text{SUPPLY}} + V_Z + V_F < V_{\text{O(SUS)}}$ ).

### Over-current conditions

In the event of a shorted load, or stalled motor, the load current will attempt to increase. As described above, the drive current to the affected output stage is linearly reduced, causing the output to go linear (limiting the load current to about 500 mA). As the junction temperature of the output stage increases, the thermal-shutdown circuit will shut off the affected output. If the fault condition is corrected, the output driver will return to its normal saturated condition.

### Fault diagnostics

A pull-up resistor or current source is required on the FAULT output. This can be connected to whatever supply level the following circuitry requires (within the specification constraints). For a 5 V supply (i.e.,  $V_{\text{CC}}$ ) 150 k $\Omega$  or greater should be used. As the fault diagnostic function is to indicate when the output state is different from the input state for any channel, the FAULT output waveform will obviously produce a pulse waveform following the combined duty-cycle of all channels showing a fault condition. There are therefore two basic approaches to using the function in an application:

- As an interrupt in a controller-based system. If the system has a microcontroller then a FAULT low causes an interrupt, which then initiates a diagnostic sequence to find the culprit channel. This sequence usually consists of cycling through each channel one at a time, while monitoring the FAULT output. It is then easy to determine which channel has the faulty output and how it is failing (i.e., short to supply, open-circuit or short to ground). The system may then take whatever action is required, but could continue with operation of the remaining 'good' channels while disabling signals to the faulty channel.
- As a simple 'common' fault indication. If there is no controller in the system then the FAULT output can be set to give an indication (via a lamp or LED, etc.) of a fault condition which might be anywhere on the four channels. Because the FAULT output is dependent on the states of the input and output (four possibilities) but will only indicate on two of them, the duty cycle at the FAULT output will reflect the duty cycle at the faulty channel's input (or its inverse, depending upon fault type).

In typical applications (50% duty cycles) a simple solution is to make the pull-up current on the FAULT output much less than the pull-down current (60  $\mu\text{A}$ ), and add a capacitor to give a time constant longer than the period of operation. For typical values, the device will produce a continuous dc output level. Component values will need to be adjusted to cope with different conditions.

# 2557 PROTECTED QUAD DRIVER WITH FAULT DETECTION & SLEEP MODE

## CIRCUIT DESCRIPTION AND APPLICATION (continued)

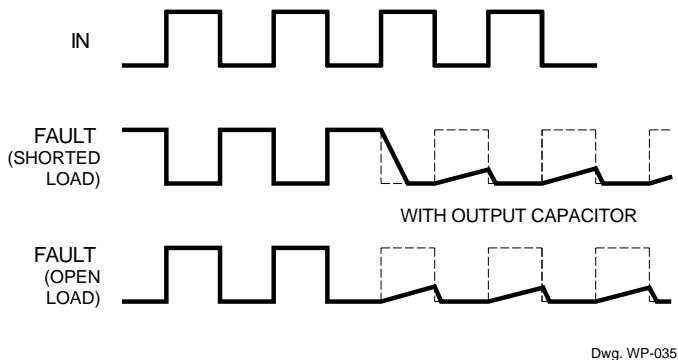

Under some conditions it is possible to get spurious glitches on the FAULT output at load turn-on and turn-off transitions:

- Light load turn-off. Under light loading conditions the turn-off delay (see characteristics above) of the output stage increases and may result in a spurious fault output of a few  $\mu\text{s}$  (the duration being proportional to the turn-off delay). As it is difficult to define this over all operating conditions, if a particular application would be sensitive to this type of glitch, then it is generally recommended to include a small (about 0.01  $\mu\text{F}$ ) smoothing/storage capacitor at the FAULT output.
- Incandescent lamp turn-on. As described above, driving an incandescent filament results in the driver operating in current limit for a period after turn-on. During this period a “fault” condition will be indicated (over current). As discussed above this period can be 10s of ms. To avoid this indication, the capacitor on the FAULT output would need to be increased to provide an appropriate time constant. Alternatively, in a microcontroller-based system, the code could be written to ignore the FAULT condition for an appropriate period after lamp turn on.

Correct FAULT operation cannot be guaranteed with an unconnected output — unused outputs should not be turned on, *or* unused outputs should be pulled high to  $>2.5\text{ V}$ , *and/or* associated inputs tied low.

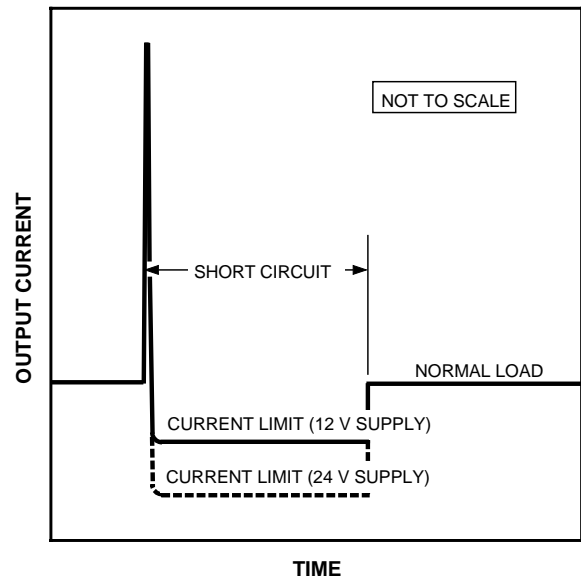

### Thermal considerations

Device power dissipation can be calculated as:

$$P_D = (V_{O1} \times I_{O1} \times \text{duty cycle}_1) + \dots + (V_{O4} \times I_{O4} \times \text{duty cycle}_4) + (V_{CC} \times I_{CC})$$

Note -  $I_{CC}$  is also modulated by the duty cycle, but this is a reasonable approximation for most purposes.

This can then be compared against the permitted package power dissipation, using:

$$\text{Permitted } P_D = (150 - T_A) / R_{\theta JA}$$

where  $R_{\theta JA}$  is given as:

- 28-lead PLCC (part number suffix ‘-EB’) = 36°C/W
- 16-pin PDIP (part number suffix ‘-B’) = 43°C/W
- 16-lead SOIC (part number suffix ‘-LB’) = 90°C/W

$R_{\theta JA}$  is measured on typical two-sided PCB with minimal copper ground area. The thermal resistance from junction to power tab ( $R_{\theta JT}$ ) is about 6°C/W for the three package types, therefore the power dissipation can be improved by 20% to 30% by adding an area of printed wiring board copper (typically 6 to 18 square centimetres) connected to the power-tab GROUND terminals of the device. See Application Note 29501.5, *Improving Batwing Power Dissipation*.

# 2557 PROTECTED QUAD DRIVER WITH FAULT DETECTION & SLEEP MODE

## A2557EB, A2557KB, & A2557SB

Dimensions in Inches  
(controlling dimensions)

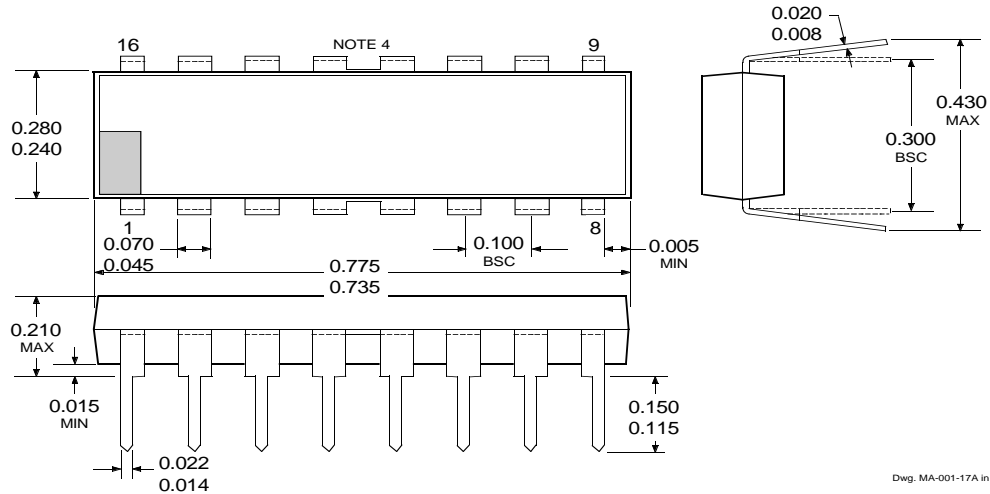

Dimensions in Millimeters  
(for reference only)

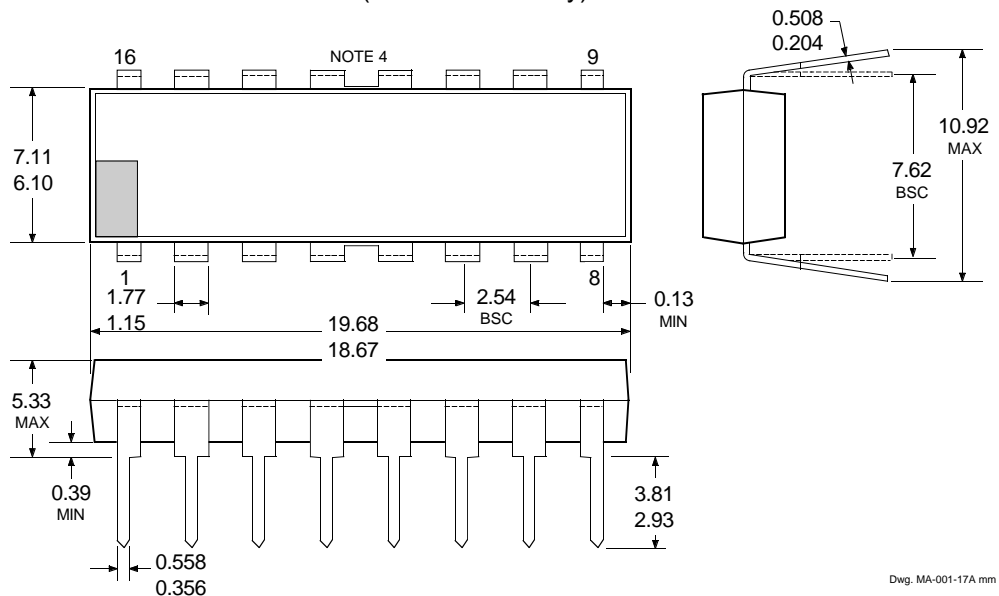

- NOTES: 1. Exact body and lead configuration at vendor's option within limits shown.  
 2. Lead spacing tolerance is non-cumulative  
 3. Lead thickness is measured at seating plane or below.  
 4. Webbed lead frame. Leads 4, 5, 12, and 13 are internally one piece.



# 2557 PROTECTED QUAD DRIVER WITH FAULT DETECTION & SLEEP MODE

## A2557ELB, A2557KLB, & A2557SLB

Dimensions in Inches  
(for reference only)

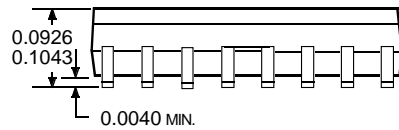
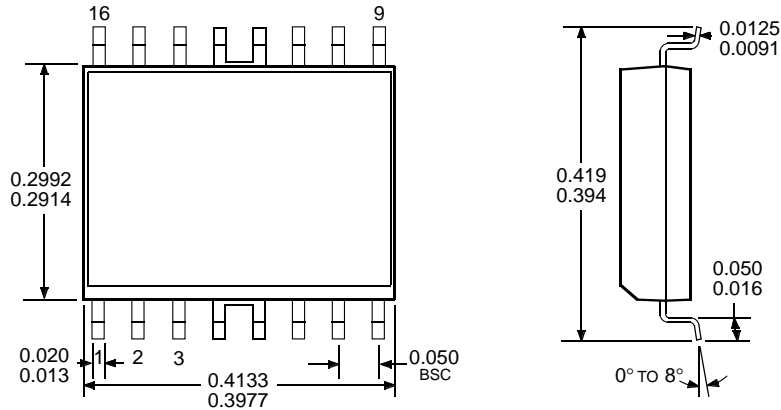

Dwg. MA-008-17A in

Dimensions in Millimeters  
(controlling dimensions)

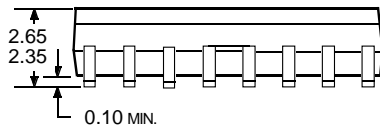
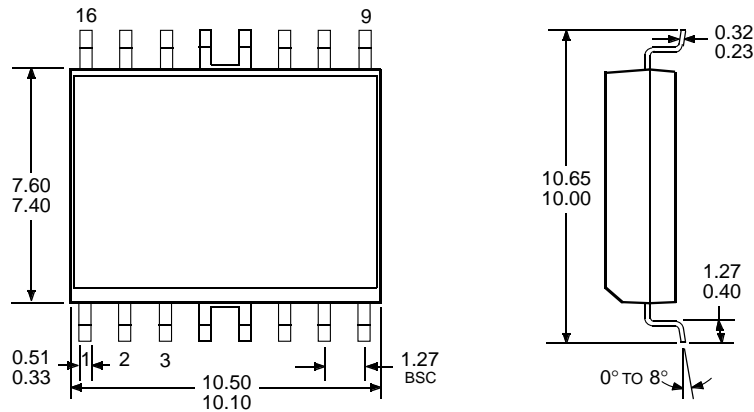

Dwg. MA-008-17A mm

- NOTES: 1. Exact body and lead configuration at vendor's option within limits shown.  
 2. Lead spacing tolerance is non-cumulative  
 3. Lead thickness is measured at seating plane or below.  
 4. Webbed lead frame. Leads 4, 5, 12, and 13 are internally one piece.



**2557**  
**PROTECTED QUAD DRIVER**  
**WITH FAULT DETECTION**  
**& SLEEP MODE**

*The products described here are manufactured under one or more U.S. patents or U.S. patents pending.*

*Allegro MicroSystems, Inc. reserves the right to make, from time to time, such departures from the detail specifications as may be required to permit improvements in the performance, reliability, or manufacturability of its products. Before placing an order, the user is cautioned to verify that the information being relied upon is current.*

*Allegro products are not authorized for use as critical components in life-support devices or systems without express written approval.*

*The information included herein is believed to be accurate and reliable. However, Allegro MicroSystems, Inc. assumes no responsibility for its use; nor for any infringement of patents or other rights of third parties which may result from its use.*

# 2557 PROTECTED QUAD DRIVER WITH FAULT DETECTION & SLEEP MODE

## POWER SINK DRIVERS

IN ORDER OF 1) OUTPUT CURRENT, 2) OUTPUT VOLTAGE, 3) NUMBER OF DRIVERS

Output Ratings *			Features					Part Number <sup>†</sup>
mA	V	#	Serial Input	Latched Drivers	Diode Clamp	Outputs	Internal Protection	
75	17	8	X	X	–	constant current	–	6275
	17	16	X	X	–	constant current	–	6276
100	20	8	–	–	–	saturated	–	2595
	30	32	X	X	–	–	–	5833
	40	32	X	X	–	saturated	–	5832
	50	8	–	–	–	addressable decoder/driver	DMOS	6B259
	50	8	–	X	–	DMOS	–	6B273
	50	8	X	X	–	DMOS	–	6B595
120	24	8	X	X	–	constant current	–	6277
250	50	8	–	–	–	addressable decoder/driver	DMOS	6259
	50	8	–	X	–	DMOS	–	6273
	50	8	X	X	–	DMOS	–	6595
	50	8	–	–	X	saturated	–	2596
	60	4	–	–	X	saturated	X	2557
350	50	4	–	X	X	–	–	5800
	50	7	–	–	X	–	–	2003
	50	7	–	–	X	–	–	2004
	50	8	–	–	X	–	–	2803
	50	8	–	X	X	–	–	5801
	50	8	X	X	–	–	–	5821
	50	8	X	X	X	–	–	5841
	50	8	–	–	–	addressable decoder/driver	DMOS	6A259
	50	8	X	X	–	DMOS	–	6A595
	80	8	X	X	–	–	–	5822
	80	8	X	X	X	–	–	5842
	95	7	–	–	X	–	–	2023
	95	7	–	–	X	–	–	2024
450	30	28	–	–	–	dual 4- to 14-line decoder/driver	–	6817
600	60	4	–	–	–	saturated	X	2547
	60	4	–	–	X	saturated	X	2549 and 2559
700	60	4	–	–	X	saturated	X	2543
750	50	8	–	–	X	saturated	–	2597
1000	46	4	–	–	–	stepper motor controller/driver	MOS	7024 and 7029
1200	46	4	–	–	–	microstepping controller/driver	MOS	7042
1250	50	4	–	–	–	stepper motor translator/driver	–	5804
1800	50	4	–	–	X	–	–	2540
3000	46	4	–	–	–	stepper motor controller/driver	MOS	7026
	46	4	–	–	–	microstepping controller/driver	MOS	7044
4000	50	4	–	–	X	–	–	2878

\* Current is maximum specified test condition, voltage is maximum rating. See specification for sustaining voltage limits or over-current protection voltage limits.

† Complete part number includes additional characters to indicate operating temperature range and package style.