

64K (8K x 8) UV EPROM and OTP ROM

- VERY FAST ACCESS TIME: 150ns
- COMPATIBLE with HIGH SPEED MICROPROCESSORS, ZERO WAIT STATE
- LOW POWER "CMOS" CONSUMPTION:
 - Active Current 30mA
 - Standby Current 100µA
- PROGRAMMING VOLTAGE: 12.5V
- ELECTRONIC SIGNATURE for AUTOMATED PROGRAMMING
- HIGH SPEED PROGRAMMING (less than 1 minute)

DESCRIPTION

The M27C64A is a high speed 65,536 bit UV erasable and electrically programmable memory EPROM ideally suited for microprocessor systems requiring large programs. It is organized as 8,192 by 8 bits.

The 28 pin Window Ceramic Frit-Seal Dual-in-Line package has transparent lid which allows the user to expose the chip to ultraviolet light to erase the bit pattern. A new pattern can then be written to the device by following the programming procedure.

For applications where the content is programmed only on time and erasure is not required, the M27C64A is offered in Plastic Leaded Chip Carrier package.

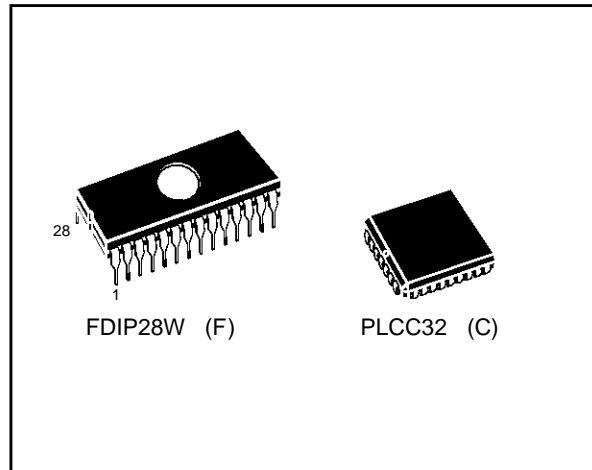

Figure 1. Logic Diagram

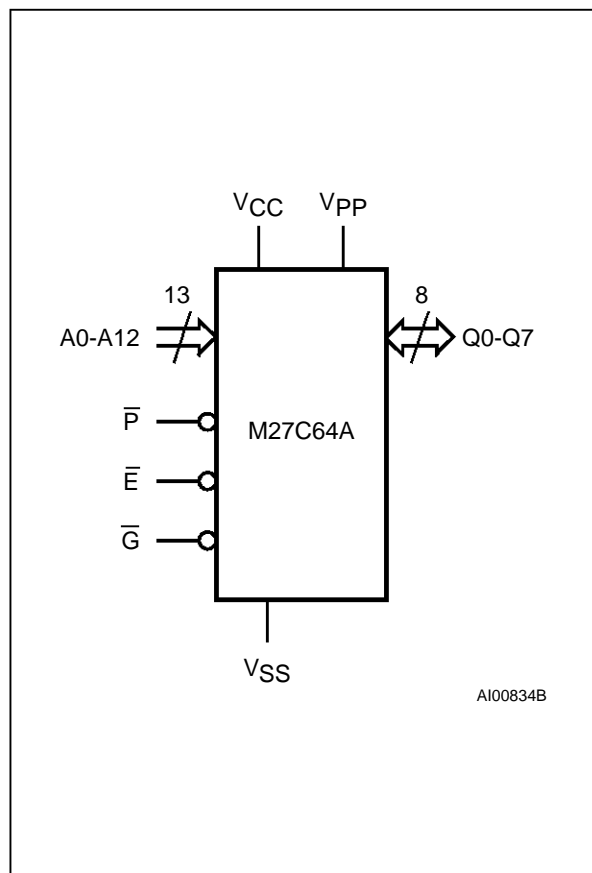
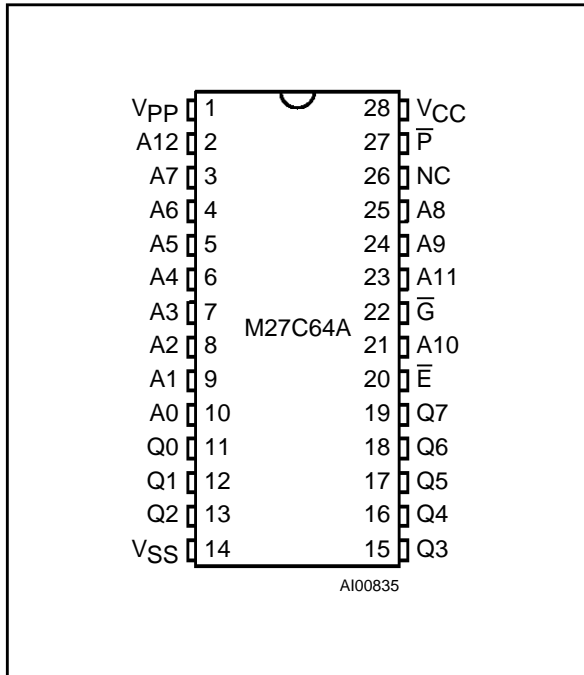

Table 1. Signal Names

A0 - A12	Address Inputs
Q0 - Q7	Data Outputs
\bar{E}	Chip Enable
\bar{G}	Output Enable
\bar{P}	Program
V _{PP}	Program Supply
V _{CC}	Supply Voltage
V _{SS}	Ground

Figure 2A. DIP Pin Connections



Warning: NC = Not Connected

Figure 2B. LCC Pin Connections

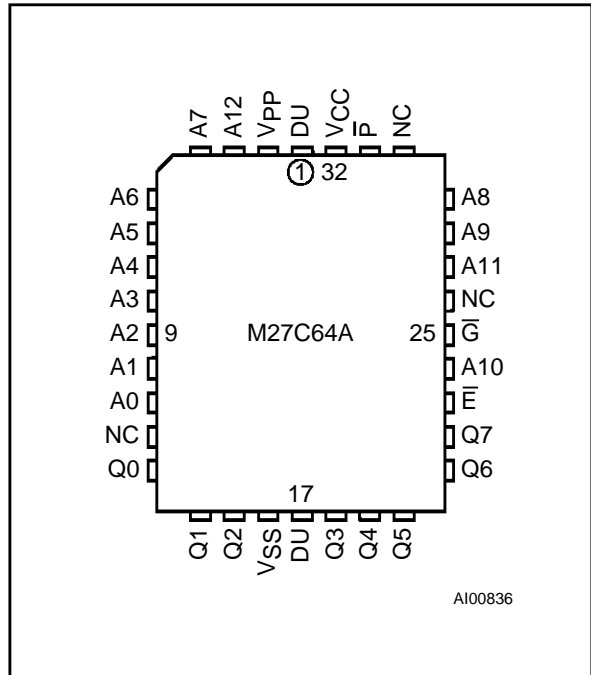

Warning: NC = Not Connected, DU = Don't Use

Table 2. Absolute Maximum Ratings ⁽¹⁾

Symbol	Parameter	Value	Unit
T _A	Ambient Operating Temperature	-40 to 125	°C
T _{BIAS}	Temperature Under Bias	-50 to 125	°C
T _{STG}	Storage Temperature	-65 to 150	°C
V _{IO (2)}	Input or Output Voltages (except A9)	-2 to 7	V
V _{CC}	Supply Voltage	-2 to 7	V
V _{A9 (2)}	A9 Voltage	-2 to 13.5	V
V _{PP}	Program Supply Voltage	-2 to 14	V

Notes: 1. Except for the rating "Operating Temperature Range", stresses above those listed in the Table "Absolute Maximum Ratings" may cause permanent damage to the device. These are stress ratings only and operation of the device at these or any other conditions above those indicated in the Operating sections of this specification is not implied. Exposure to Absolute Maximum Rating conditions for extended periods may affect device reliability. Refer also to the SGS-THOMSON SURE Program and other relevant quality documents.

2. Minimum DC voltage on Input or Output is -0.5V with possible undershoot to -2.0V for a period less than 20ns. Maximum DC voltage on Output is V_{CC} +0.5V with possible overshoot to V_{CC} +2V for a period less than 20ns.

DEVICE OPERATION

The modes of operation of the M27C64A are listed in the Operating Modes table. A single 5V power supply is required in the read mode. All inputs are TTL levels except for V_{PP} and 12V on A9 for Electronic Signature.

Read Mode

The M27C64A has two control functions, both of which must be logically active in order to obtain data at the outputs. Chip Enable (\bar{E}) is the power control and should be used for device selection. Output Enable (\bar{G}) is the output control and should

be used to gate data to the output pins, independent of device selection. Assuming that the addresses are stable, the address access time (t_{AVQV}) is equal to the delay from \bar{E} to output (t_{ELQV}). Data is available at the output after a delay of t_{GLQV} from the falling edge of \bar{G} , assuming that \bar{E} has been low and the addresses have been stable for at least $t_{AVQV} - t_{GLQV}$.

Standby Mode

The M27C64A has a standby mode which reduces the active current from 30mA to 100 μ A. The M27C64A is placed in the standby mode by applying a CMOS high signal to the \bar{E} input. When in the standby mode, the outputs are in a high impedance state, independent of the \bar{G} input.

Two Line Output Control

Because EPROMs are usually used in larger memory arrays, this product features a 2 line control function which accommodates the use of multiple memory connection. The two line control function allows:

- the lowest possible memory power dissipation,
- complete assurance that output bus contention will not occur.

For the most efficient use of these two control lines, \bar{E} should be decoded and used as the primary device selecting function, while \bar{G} should be made a common connection to all devices in the array and connected to the READ line from the system

control bus. This ensures that all deselected memory devices are in their low power standby mode and that the output pins are only active when data is required from a particular memory device.

System Considerations

The power switching characteristics of Advanced CMOS EPROMs require careful decoupling of the devices. The supply current, I_{CC} , has three segments that are of interest to the system designer: the standby current level, the active current level, and transient current peaks that are produced by the falling and rising edges of \bar{E} . The magnitude of the transient current peaks is dependent on the capacitive and inductive loading of the device at the output.

The associated transient voltage peaks can be suppressed by complying with the two line output control and by properly selected decoupling capacitors. It is recommended that a 0.1 μ F ceramic capacitor be used on every device between V_{CC} and V_{SS} . This should be a high frequency capacitor of low inherent inductance and should be placed as close to the device as possible. In addition, a 4.7 μ F bulk electrolytic capacitor should be used between V_{CC} and V_{SS} for every eight devices. The bulk capacitor should be located near the power supply connection point. The purpose of the bulk capacitor is to overcome the voltage drop caused by the inductive effects of PCB traces.

Table 3. Operating Modes

Mode	\bar{E}	\bar{G}	\bar{P}	A9	V_{PP}	Q0 - Q7
Read	V_{IL}	V_{IL}	V_{IH}	X	V_{CC}	Data Out
Output Disable	V_{IL}	V_{IH}	V_{IH}	X	V_{CC}	Hi-Z
Program	V_{IL}	V_{IH}	V_{IL} Pulse	X	V_{PP}	Data In
Verify	V_{IL}	V_{IL}	V_{IH}	X	V_{PP}	Data Out
Program Inhibit	V_{IH}	X	X	X	V_{PP}	Hi-Z
Standby	V_{IH}	X	X	X	V_{CC}	Hi-Z
Electronic Signature	V_{IL}	V_{IL}	V_{IH}	V_{ID}	V_{CC}	Codes

Note: X = V_{IH} or V_{IL} , $V_{ID} = 12V \pm 0.5V$

Table 4. Electronic Signature

Identifier	A0	Q7	Q6	Q5	Q4	Q3	Q2	Q1	Q0	Hex Data
Manufacturer's Code	V_{IL}	1	0	0	1	1	0	1	1	9Bh
Device Code	V_{IH}	0	0	0	0	1	0	0	0	08h

AC MEASUREMENT CONDITIONS

Input Rise and Fall Times $\leq 20\text{ns}$
 Input Pulse Voltages 0.4 to 2.4V
 Input and Output Timing Ref. Voltages 0.8 to 2.0V

Note that Output Hi-Z is defined as the point where data is no longer driven.

Figure 3. AC Testing Input Output Waveforms

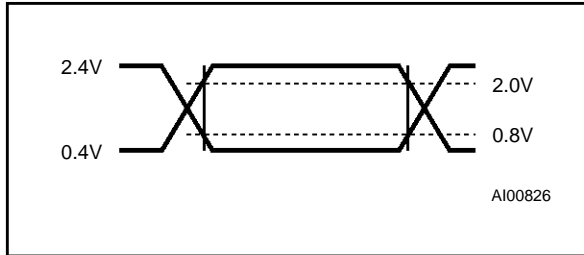

Figure 4. AC Testing Load Circuit

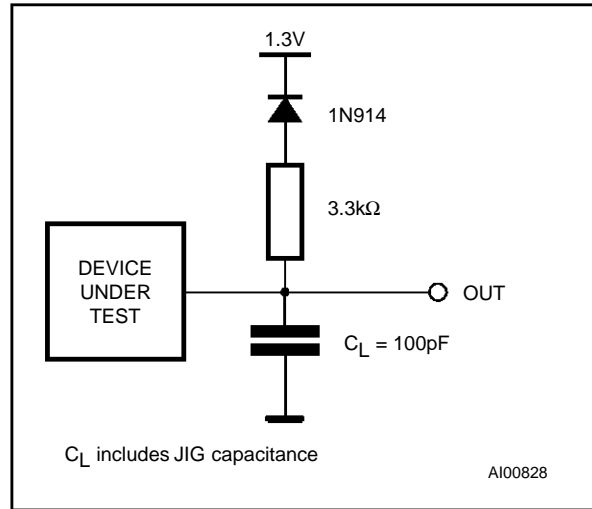

Table 5. Capacitance⁽¹⁾ ($T_A = 25\text{ }^\circ\text{C}$, $f = 1\text{ MHz}$)

Symbol	Parameter	Test Condition	Min	Max	Unit
C_{IN}	Input Capacitance	$V_{IN} = 0V$		6	pF
C_{OUT}	Output Capacitance	$V_{OUT} = 0V$		12	pF

Note: 1. Sampled only, not 100% tested.

Figure 5. Read Mode AC Waveforms

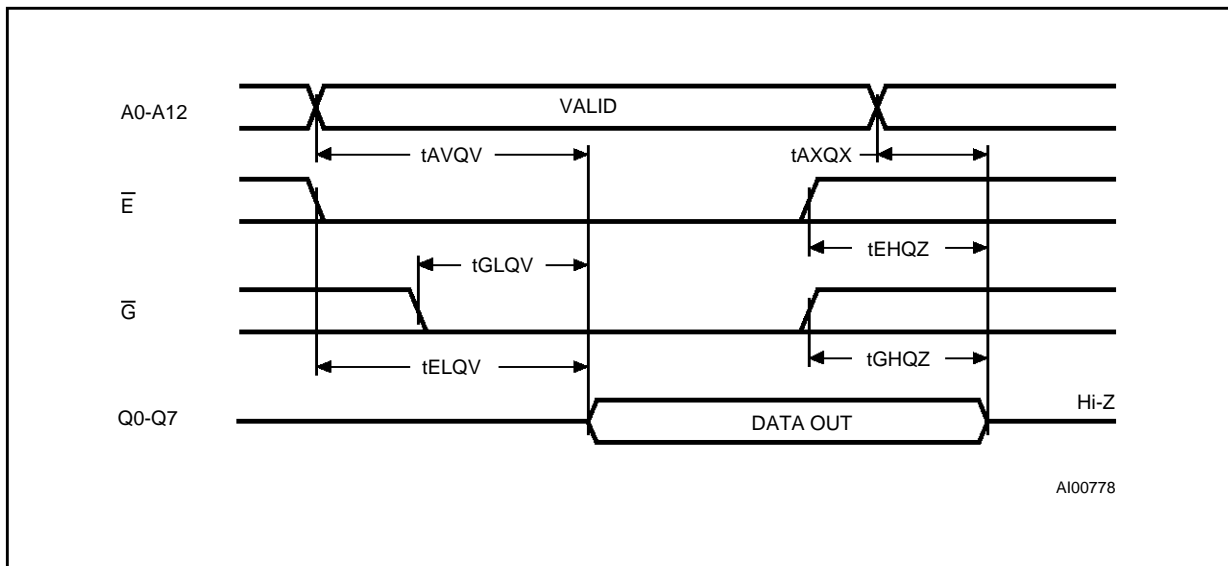

Table 6. Read Mode DC Characteristics ⁽¹⁾(T_A = 0 to 70 °C or -40 to 85 °C: V_{CC} = 5V ± 10%; V_{PP} = V_{CC})

Symbol	Parameter	Test Condition	Min	Max	Unit
I _{LI}	Input Leakage Current	0V ≤ V _{IN} ≤ V _{CC}		±10	μA
I _{LO}	Output Leakage Current	0V ≤ V _{OUT} ≤ V _{CC}		±10	μA
I _{CC}	Supply Current	$\bar{E} = V_{IL}, \bar{G} = V_{IL},$ I _{OUT} = 0mA, f = 5MHz		30	mA
I _{CC1}	Supply Current (Standby) TTL	$\bar{E} = V_{IH}$		1	mA
I _{CC2}	Supply Current (Standby) CMOS	$\bar{E} > V_{CC} - 0.2V$		100	μA
I _{PP}	Program Current	V _{PP} = V _{CC}		100	μA
V _{IL}	Input Low Voltage		-0.3	0.8	V
V _{IH} ⁽²⁾	Input High Voltage		2	V _{CC} + 1	V
V _{OL}	Output Low Voltage	I _{OL} = 2.1mA		0.4	V
V _{OH}	Output High Voltage TTL	I _{OH} = -400μA	2.4		V
	Output High Voltage CMOS	I _{OH} = -100μA	V _{CC} - 0.7V		V

Notes: 1. V_{CC} must be applied simultaneously with or before V_{PP} and removed simultaneously with or after V_{PP}.
2. Maximum DC voltage on Output is V_{CC} + 0.5V.

Table 7. Read Mode AC Characteristics ⁽¹⁾(T_A = 0 to 70 °C or -40 to 85 °C: V_{CC} = 5V ± 10%; V_{PP} = V_{CC})

Symbol	Alt	Parameter	Test Condition	M27C64A								Unit
				-15		-20		-25		-30		
				Min	Max	Min	Max	Min	Max	Min	Max	
t _{AVQV}	t _{ACC}	Address Valid to Output Valid	$\bar{E} = V_{IL}, \bar{G} = V_{IL}$		150		200		250		300	ns
t _{ELQV}	t _{CE}	Chip Enable Low to Output Valid	$\bar{G} = V_{IL}$		150		200		250		300	ns
t _{GLQV}	t _{OE}	Output Enable Low to Output Valid	$\bar{E} = V_{IL}$		75		80		100		120	ns
t _{EHQZ} ⁽²⁾	t _{DF}	Chip Enable High to Output Hi-Z	$\bar{G} = V_{IL}$	0	50	0	50	0	60	0	105	ns
t _{GHQZ} ⁽²⁾	t _{DF}	Output Enable High to Output Hi-Z	$\bar{E} = V_{IL}$	0	50	0	50	0	60	0	105	ns
t _{AXQX}	t _{OH}	Address Transition to Output Transition	$\bar{E} = V_{IL}, \bar{G} = V_{IL}$	0		0		0		0		ns

Notes: 1. V_{CC} must be applied simultaneously with or before V_{PP} and removed simultaneously with or after V_{PP}.
2. Sampled only, not 100% tested.

Table 8. Programming Mode DC Characteristics ⁽¹⁾
 (T_A = 25 °C; V_{CC} = 6V ± 0.25V; V_{PP} = 12.5V ± 0.3V)

Symbol	Parameter	Test Condition	Min	Max	Unit
I _{LI}	Input Leakage Current	V _{IL} ≤ V _{IN} ≤ V _{IH}		±10	μA
I _{CC}	Supply Current			30	mA
I _{PP}	Program Current	$\bar{E} = V_{IL}$		30	mA
V _{IL}	Input Low Voltage		-0.3	0.8	V
V _{IH}	Input High Voltage		2	V _{CC} + 0.5	V
V _{OL}	Output Low Voltage	I _{OL} = 2.1mA		0.4	V
V _{OH}	Output High Voltage TTL	I _{OH} = -400μA	2.4		V
V _{ID}	A9 Voltage		11.5	12.5	V

Note: 1. V_{CC} must be applied simultaneously with or before V_{PP} and removed simultaneously or after V_{PP}.

Table 9. Programming Mode AC Characteristics ⁽¹⁾
 (T_A = 25 °C; V_{CC} = 6V ± 0.25V; V_{PP} = 12.5V ± 0.3V)

Symbol	Alt	Parameter	Test Condition	Min	Max	Unit
t _{AVPL}	t _{AS}	Address Valid to Program Low		2		μs
t _{QVPL}	t _{DS}	Input Valid to Program Low		2		μs
t _{VPHPL}	t _{PS}	V _{PP} High to Program Low		2		μs
t _{VCHPL}	t _{CS}	V _{CC} High to Program Low		2		μs
t _{ELPL}	t _{CES}	Chip Enable Low to Program Low		2		μs
t _{PLPH}	t _{PW}	Program Pulse Width (Initial)		0.95	1.05	ms
		Program Pulse Width (Over Program)		2.85	78.75	ms
t _{PHQX}	t _{DH}	Program High to Input Transition		2		μs
t _{QXGL}	t _{OES}	Input Transition to Output Enable Low		2		μs
t _{GLQV}	t _{OE}	Output Enable Low to Output Valid			100	ns
t _{GHQZ} ⁽²⁾	t _{DFP}	Output Enable High to Output Hi-Z		0	130	ns
t _{GHAX}	t _{AH}	Output Enable High to Address Transition		0		ns

Notes: 1. V_{CC} must be applied simultaneously with or before V_{PP} and removed simultaneously or after V_{PP}.

2. Sampled only, not 100% tested.

Figure 6. Programming and Verify Modes AC Waveforms

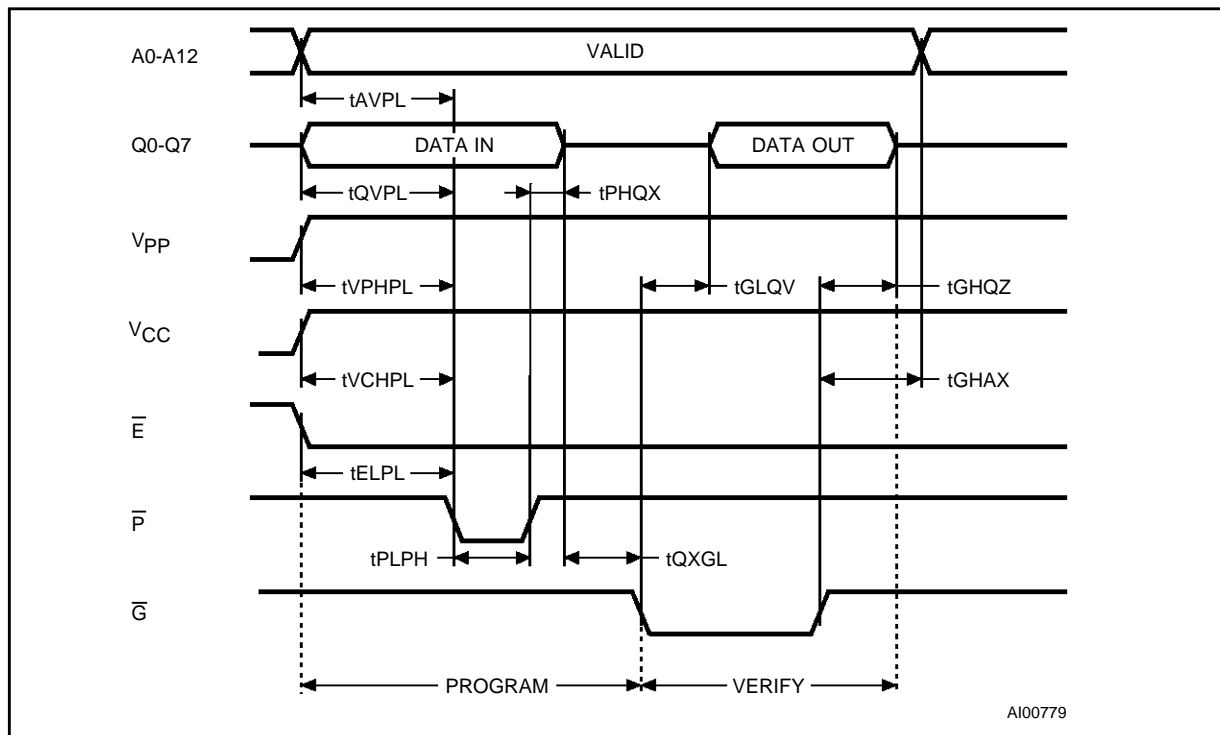
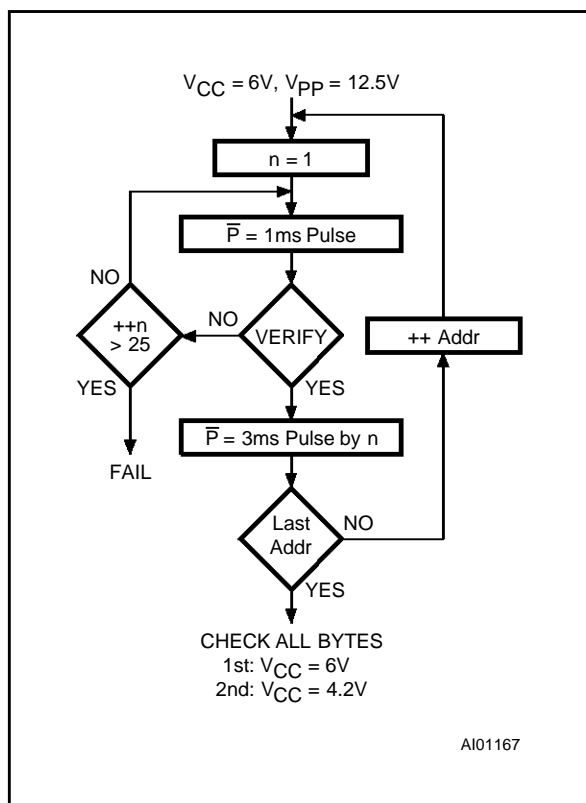

Figure 7. Programming Flowchart



Programming

When delivered (and after each erasure for UV EPROM), all bits of the M27C64A are in the "1" state. Data is introduced by selectively programming "0s" into the desired bit locations. Although only "0s" will be programmed, both "1s" and "0s" can be present in the data word. The only way to change a "0" to a "1" is by die exposition to ultraviolet light (UV EPROM). The M27C64A is in the programming mode when V_{pp} input is at 12.5V, and \bar{E} and \bar{P} are at TTL-low. The data to be programmed is applied 8 bits in parallel to the data output pins. The levels required for the address and data inputs are TTL. V_{CC} is specified to be 6V ± 0.25V.

High Speed Programming

The high speed programming algorithm, described in the flowchart, rapidly programs the M27C64A using an efficient and reliable method, particularly suited to the production programming environment. An individual device will take around 1 minute to program.

Program Inhibit

Programming of multiple M27C64A in parallel with different data is also easily accomplished. Except for \bar{E} , all like inputs including \bar{G} of the parallel M27C64A may be common. A TTL low level pulse applied to a M27C64A \bar{E} input, with \bar{P} low and V_{PP}

DEVICE OPERATIONS (cont'd)

at 12.5V, will program that M27C64A. A high level \bar{E} input inhibits the other M27C64A from being programmed.

Program Verify

A verify (read) should be performed on the programmed bits to determine that they were correctly programmed. The verify is accomplished with \bar{E} and \bar{G} at V_{IL} , \bar{P} at V_{IH} , V_{PP} at 12.5V and V_{CC} at 6V.

Electronic Signature

The Electronic Signature mode allows the reading out of a binary code from an EPROM that will identify its manufacturer and type. This mode is intended for use by programming equipment to automatically match the device to be programmed with its corresponding programming algorithm. This mode is functional in the $25^{\circ}\text{C} \pm 5^{\circ}\text{C}$ ambient temperature range that is required when programming the M27C64A. To activate this mode, the programming equipment must force 11.5V to 12.5V on address line A9 of the M27C64A, with $V_{PP}=V_{CC}=5\text{V}$. Two identifier bytes may then be sequenced from the device outputs by toggling address line A0 from V_{IL} to V_{IH} . All other address lines must be held at V_{IL} during Electronic Signature mode.

Byte 0 ($A0=V_{IL}$) represents the manufacturer code and byte 1 ($A0=V_{IH}$) the device identifier code. For

the SGS-THOMSON M27C64A, these two identifier bytes are given in Table 4 and can be read-out on outputs Q0 to Q7.

ERASURE OPERATION (applies to UV EPROM)

The erasure characteristics of the M27C64A is such that erasure begins when the cells are exposed to light with wavelengths shorter than approximately 4000 Å. It should be noted that sunlight and some type of fluorescent lamps have wavelengths in the 3000-4000 Å range. Research shows that constant exposure to room level fluorescent lighting could erase a typical M27C64A in about 3 years, while it would take approximately 1 week to cause erasure when exposed to direct sunlight. If the M27C64A is to be exposed to these types of lighting conditions for extended periods of time, it is suggested that opaque labels be put over the M27C64A window to prevent unintentional erasure. The recommended erasure procedure for the M27C64A is exposure to short wave ultraviolet light which has a wavelength of 2537 Å. The integrated dose (i.e. UV intensity x exposure time) for erasure should be a minimum of 15 W-sec/cm². The erasure time with this dosage is approximately 15 to 20 minutes using an ultraviolet lamp with 12000 uW/cm² power rating. The M27C64A should be placed within 2.5 cm (1 inch) of the lamp tubes during the erasure. Some lamps have a filter on their tubes which should be removed before erasure.

ORDERING INFORMATION SCHEME

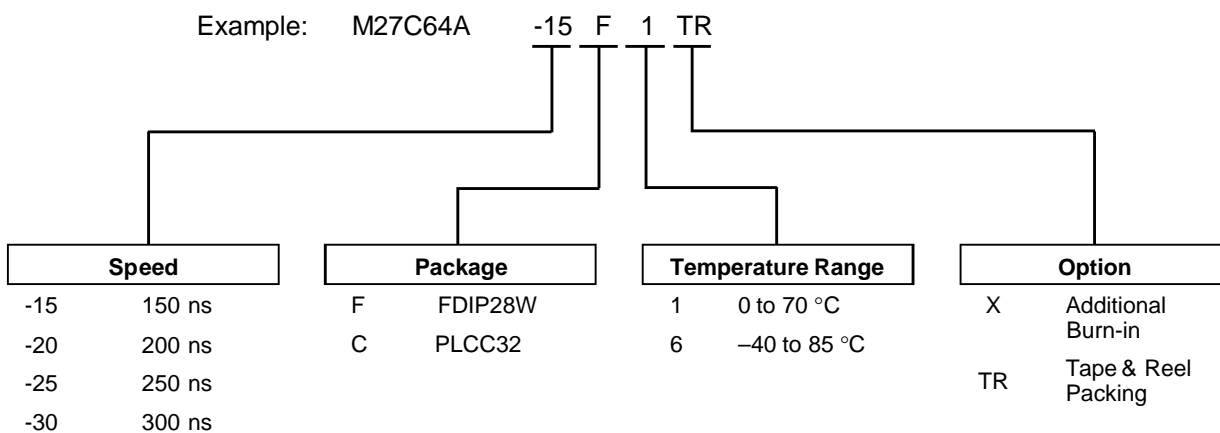

For a list of available options (Speed, Package, etc...) refer to the current Memory Shortform catalogue. For further information on any aspect of this device, please contact SGS-THOMSON Sales Office nearest to you.

FDIP28W - 28 pin Ceramic Frit-seal DIP, with window

Symb	mm			inches		
	Typ	Min	Max	Typ	Min	Max
A			5.71			0.225
A1		0.50	1.78		0.020	0.070
A2		3.90	5.08		0.154	0.200
B		0.40	0.55		0.016	0.022
B1		1.17	1.42		0.046	0.056
C		0.22	0.31		0.009	0.012
D			38.10			1.500
E		15.40	15.80		0.606	0.622
E1		13.05	13.36		0.514	0.526
e1	2.54	–	–	0.100	–	–
e3	33.02	–	–	1.300	–	–
eA		16.17	18.32		0.637	0.721
L		3.18	4.10		0.125	0.161
S		1.52	2.49		0.060	0.098
∅	7.11	–	–	0.280	–	–
α		4°	15°		4°	15°
N		28			28	

FDIP28W

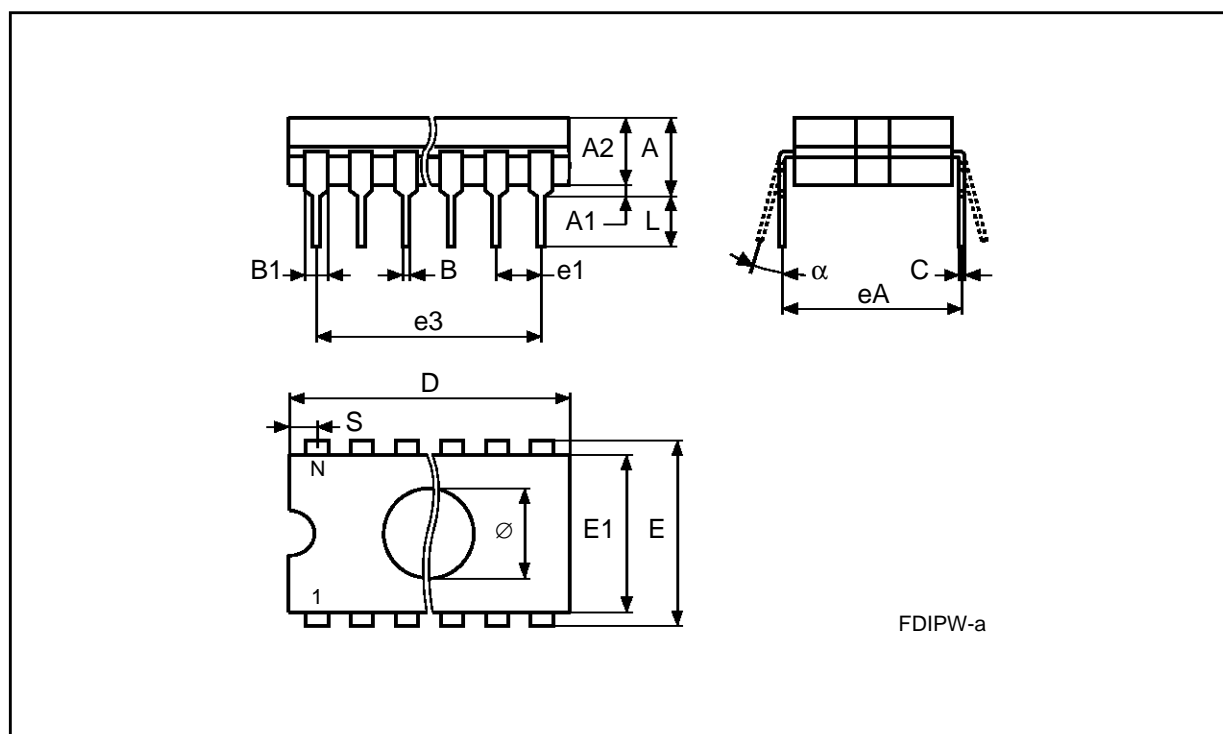

Drawing is no to scale

PLCC32 - 32 lead Plastic Leaded Chip Carrier - rectangular

Symb	mm			inches		
	Typ	Min	Max	Typ	Min	Max
A		2.54	3.56		0.100	0.140
A1		1.52	2.41		0.060	0.095
B		0.33	0.53		0.013	0.021
B1		0.66	0.81		0.026	0.032
D		12.32	12.57		0.485	0.495
D1		11.35	11.56		0.447	0.455
D2		9.91	10.92		0.390	0.430
E		14.86	15.11		0.585	0.595
E1		13.89	14.10		0.547	0.555
E2		12.45	13.46		0.490	0.530
e	1.27	-	-	0.050	-	-
N	32			32		
Nd	7			7		
Ne	9			9		
CP			0.10			0.004

PLCC32

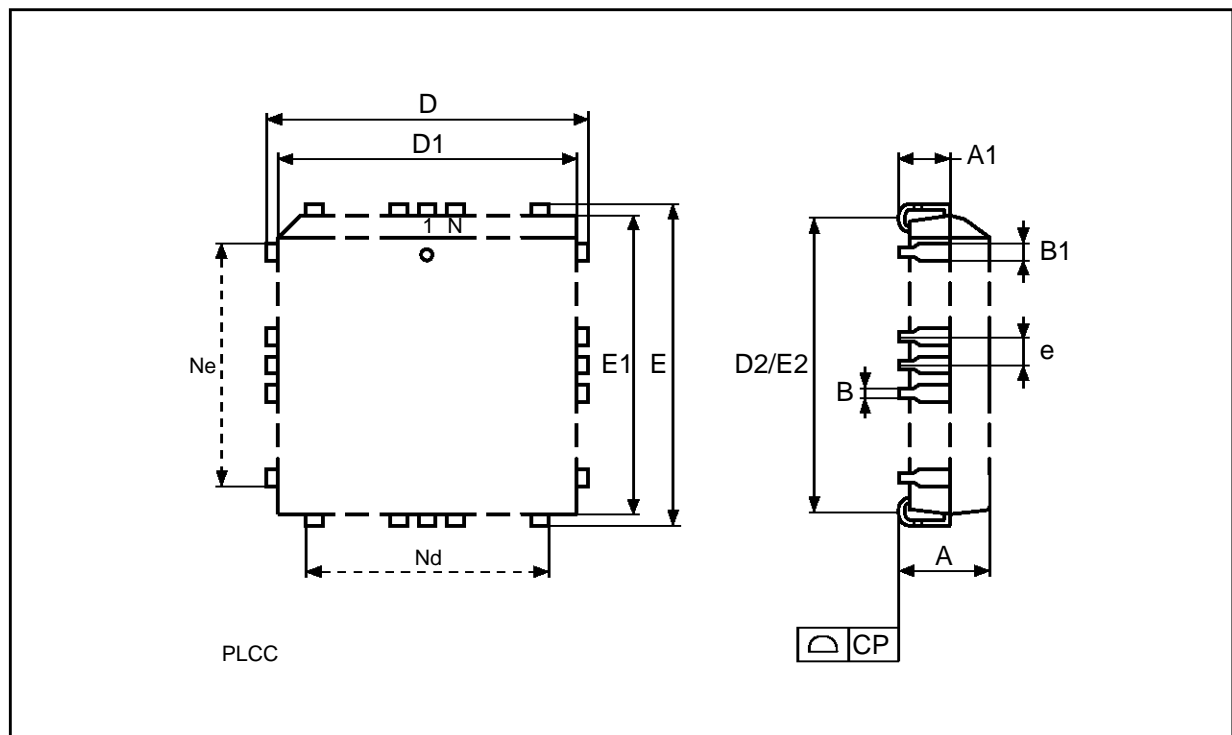

Drawing is no to scale

Information furnished is believed to be accurate and reliable. However, SGS-THOMSON Microelectronics assumes no responsibility for the consequences of use of such information nor for any infringement of patents or other rights of third parties which may result from its use. No license is granted by implication or otherwise under any patent or patent rights of SGS-THOMSON Microelectronics. Specifications mentioned in this publication are subject to change without notice. This publication supersedes and replaces all information previously supplied. SGS-THOMSON Microelectronics products are not authorized for use as critical components in life support devices or systems without express written approval of SGS-THOMSON Microelectronics.

© 1995 SGS-THOMSON Microelectronics - All Rights Reserved

SGS-THOMSON Microelectronics GROUP OF COMPANIES
Australia - Brazil - China - France - Germany - Hong Kong - Italy - Japan - Korea - Malaysia - Malta - Morocco - The Netherlands -
Singapore - Spain - Sweden - Switzerland - Taiwan - Thailand - United Kingdom - U.S.A.