

Features

- Fast Read Access Time - 120 ns
- Automatic Page Write Operation
 - Internal Address and Data Latches for 128-Bytes
 - Internal Control Timer
- Fast Write Cycle Time
 - Page Write Cycle Time - 10 ms Maximum
 - 1 to 128-Byte Page Write Operation
- Low Power Dissipation
 - 40 mA Active Current
 - 200 μ A CMOS Standby Current
- Hardware and Software Data Protection
- DATA Polling for End of Write Detection
- High Reliability CMOS Technology
 - Endurance: 10^4 or 10^5 Cycles
 - Data Retention: 10 Years
- Single 5V \pm 10% Supply
- CMOS and TTL Compatible Inputs and Outputs
- JEDEC Approved Byte-Wide Pinout
- Commercial and Industrial Temperature Ranges

Description

The AT28C010 is a high-performance Electrically Erasable and Programmable Read Only Memory. Its 1 megabit of memory is organized as 131,072 words by 8 bits. Manufactured with Atmel's advanced nonvolatile CMOS technology, the device offers access times to 120 ns with power dissipation of just 220 mW. When the device is deselected, the CMOS standby current is less than 200 μ A.

(continued)

Pin Configurations

Pin Name	Function
A0 - A16	Addresses
$\overline{\text{CE}}$	Chip Enable
$\overline{\text{OE}}$	Output Enable
$\overline{\text{WE}}$	Write Enable
I/O0 - I/O7	Data Inputs/Outputs
NC	No Connect
DC	Don't Connect

TSOP
Top View



PLCC
Top View

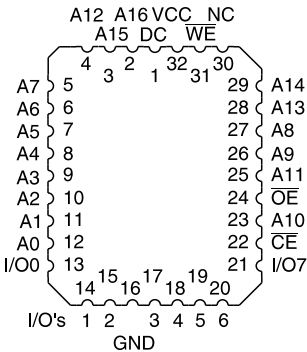

Note: PLCC package pin 1 is a DON'T CONNECT.

PDIP
Top View

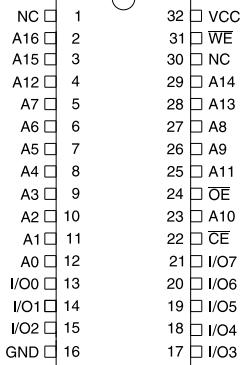

**1 Megabit
(128K x 8)
Paged
CMOS
E²PROM**

**Commercial
and
Industrial**



Description (Continued)

The AT28C010 is accessed like a Static RAM for the read or write cycle without the need for external components. The device contains a 128-byte page register to allow writing of up to 128-bytes simultaneously. During a write cycle, the address and 1 to 128-bytes of data are internally latched, freeing the address and data bus for other operations. Following the initiation of a write cycle, the device will automatically write the latched data using an internal control timer. The end of a write cycle can be detected by DATA POLLING of I/O7. Once the end of a write cycle has been detected a new access for a read or write can begin.

Atmel's 28C010 has additional features to ensure high quality and manufacturability. The device utilizes internal error correction for extended endurance and improved data retention characteristics. An optional software data protection mechanism is available to guard against inadvertent writes. The device also includes an extra 128-bytes of E²PROM for device identification or tracking.

Block Diagram

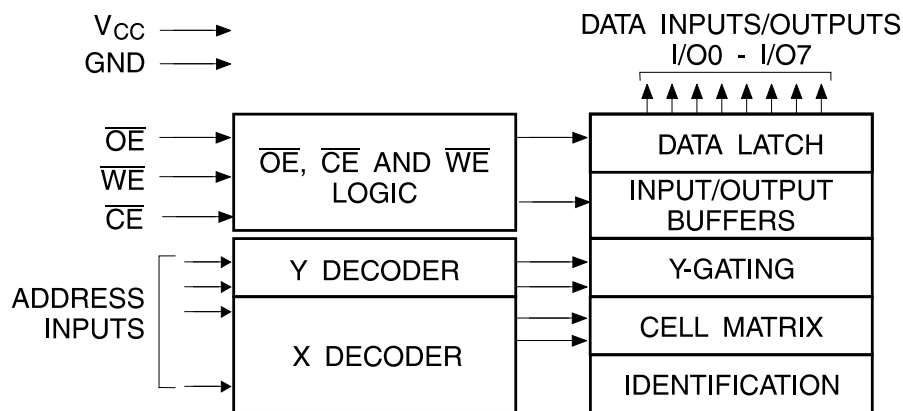

Absolute Maximum Ratings*

Temperature Under Bias.....	-55°C to +125°C
Storage Temperature.....	-65°C to +150°C
All Input Voltages (including NC Pins) with Respect to Ground	-0.6V to +6.25V
All Output Voltages with Respect to Ground	-0.6V to V _{cc} + 0.6V
Voltage on \overline{OE} and A9 with Respect to Ground	-0.6V to +13.5V

*NOTICE: Stresses beyond those listed under "Absolute Maximum Ratings" may cause permanent damage to the device. This is a stress rating only and functional operation of the device at these or any other conditions beyond those indicated in the operational sections of this specification is not implied. Exposure to absolute maximum rating conditions for extended periods may affect device reliability.

Device Operation

READ: The AT28C010 is accessed like a Static RAM. When \overline{CE} and \overline{OE} are low and \overline{WE} is high, the data stored at the memory location determined by the address pins is asserted on the outputs. The outputs are put in the high impedance state when either \overline{CE} or \overline{OE} is high. This dual-line control gives designers flexibility in preventing bus contention in their system.

BYTE WRITE: A low pulse on the \overline{WE} or \overline{CE} input with \overline{CE} or \overline{WE} low (respectively) and \overline{OE} high initiates a write cycle. The address is latched on the falling edge of \overline{CE} or \overline{WE} , whichever occurs last. The data is latched by the first rising edge of \overline{CE} or \overline{WE} . Once a byte write has been started it will automatically time itself to completion. Once a programming operation has been initiated and for the duration of t_{WC} , a read operation will effectively be a polling operation.

PAGE WRITE: The page write operation of the AT28C010 allows 1 to 128-bytes of data to be written into the device during a single internal programming period. A page write operation is initiated in the same manner as a byte write; the first byte written can then be followed by 1 to 127 additional bytes. Each successive byte must be written within 150 μ s (t_{BLC}) of the previous byte. If the t_{BLC} limit is exceeded the AT28C010 will cease accepting data and commence the internal programming operation. All bytes during a page write operation must reside on the same page as defined by the state of the A7 - A16 inputs. For each \overline{WE} high to low transition during the page write operation, A7 - A16 must be the same.

The A0 to A6 inputs are used to specify which bytes within the page are to be written. The bytes may be loaded in any order and may be altered within the same load period. Only bytes which are specified for writing will be written; unnecessary cycling of other bytes within the page does not occur.

DATA POLLING: The AT28C010 features \overline{DATA} Polling to indicate the end of a write cycle. During a byte or page write cycle an attempted read of the last byte written will result in the complement of the written data to be presented on I/O7. Once the write cycle has been completed, true data is valid on all outputs, and the next write cycle may begin. \overline{DATA} Polling may begin at anytime during the write cycle.

TOGGLE BIT: In addition to \overline{DATA} Polling the AT28C010 provides another method for determining the end of a write cycle. During the write operation, successive attempts to read data from the device will result in I/O6 toggling between one and zero. Once the write has completed, I/O6 will stop toggling and valid data will be read. Reading the toggle bit may begin at any time during the write cycle.

DATA PROTECTION: If precautions are not taken, inadvertent writes may occur during transitions of the host system power supply. Atmel has incorporated both hardware and software features that will protect the memory against inadvertent writes.

HARDWARE PROTECTION: Hardware features protect against inadvertent writes to the AT28C010 in the following ways: (a) V_{CC} sense - if V_{CC} is below 3.8V (typical) the write function is inhibited; (b) V_{CC} power-on delay - once V_{CC} has reached 3.8V the device will automatically time out 5 ms (typical) before allowing a write; (c) write inhibit - holding any one of \overline{OE} low, \overline{CE} high or \overline{WE} high inhibits write cycles; (d) noise filter - pulses of less than 15 ns (typical) on the \overline{WE} or \overline{CE} inputs will not initiate a write cycle.

SOFTWARE DATA PROTECTION: A software controlled data protection feature has been implemented on the AT28C010. When enabled, the software data protection (SDP), will prevent inadvertent writes. The SDP feature may be enabled or disabled by the user; the AT28C010 is shipped from Atmel with SDP disabled.

SDP is enabled by the host system issuing a series of three write commands; three specific bytes of data are written to three specific addresses (refer to Software Data Protection Algorithm). After writing the 3-byte command sequence and after t_{WC} the entire AT28C010 will be protected against inadvertent write operations. It should be noted, that once protected the host may still perform a byte or page write to the AT28C010. This is done by preceding the data to be written by the same 3-byte command sequence used to enable SDP.

Once set, SDP will remain active unless the disable command sequence is issued. Power transitions do not disable SDP and SDP will protect the AT28C010 during power-up and power-down conditions. All command sequences must conform to the page write timing specifications. The data in the enable and disable command sequences is not written to the device and the memory addresses used in the sequence may be written with data in either a byte or page write operation.

After setting SDP, any attempt to write to the device without the 3-byte command sequence will start the internal write timers. No data will be written to the device; however, for the duration of t_{WC} , read operations will effectively be polling operations.

(continued)



Device Operation (Continued)

DEVICE IDENTIFICATION: An extra 128-bytes of E²PROM memory are available to the user for device identification. By raising A9 to $12V \pm 0.5V$ and using address locations 1FF80H to 1FFFFH the bytes may be written to or read from in the same manner as the regular memory array.

OPTIONAL CHIP ERASE MODE: The entire device can be erased using a 6-byte software code. Please see Software Chip Erase application note for details.

DC and AC Operating Range

		AT28C010-12	AT28C010-15	AT28C010-20
Operating Temperature (Case)	Com.	0°C - 70°C	0°C - 70°C	0°C - 70°C
	Ind.	-40°C - 85°C	-40°C - 85°C	-40°C - 85°C
V _{CC} Power Supply		5V ± 10%	5V ± 10%	5V ± 10%

Operating Modes

Mode	\overline{CE}	\overline{OE}	\overline{WE}	I/O
Read	V _{IL}	V _{IL}	V _{IH}	D _{OUT}
Write ⁽²⁾	V _{IL}	V _{IH}	V _{IL}	D _{IN}
Standby/Write Inhibit	V _{IH}	X ⁽¹⁾	X	High Z
Write Inhibit	X	X	V _{IH}	
Write Inhibit	X	V _{IL}	X	
Output Disable	X	V _{IH}	X	High Z

Notes: 1. X can be V_{IL} or V_{IH}.
2. Refer to AC Programming Waveforms.

DC Characteristics

Symbol	Parameter	Condition	Min	Max	Units
I _{LI}	Input Load Current	V _{IN} = 0V to V _{CC} + 1V		10	μA
I _{LO}	Output Leakage Current	V _{I/O} = 0V to V _{CC}		10	μA
I _{SB1}	V _{CC} Standby Current CMOS	$\overline{CE} = V_{CC} - 0.3V$ to V _{CC} + 1V		200	μA
I _{SB2}	V _{CC} Standby Current TTL	$\overline{CE} = 2.0V$ to V _{CC} + 1V		3	mA
I _{CC}	V _{CC} Active Current	f = 5 MHz; I _{OUT} = 0 mA		40	mA
V _{IL}	Input Low Voltage			0.8	V
V _{IH}	Input High Voltage		2.0		V
V _{OL}	Output Low Voltage	I _{OL} = 2.1 mA		.45	V
V _{OH1}	Output High Voltage	I _{OH} = -400 μA	2.4		V
V _{OH2}	Output High Voltage CMOS	I _{OH} = -100 μA; V _{CC} = 4.5V	4.2		V

AC Read Characteristics

Symbol	Parameter	AT28C010-12		AT28C010-15		AT28C010-20		Units
		Min	Max	Min	Max	Min	Max	
t_{ACC}	Address to Output Delay		120		150		200	ns
$t_{CE}^{(1)}$	\overline{CE} to Output Delay		120		150		200	ns
$t_{OE}^{(2)}$	\overline{OE} to Output Delay	0	50	0	55	0	55	ns
$t_{DF}^{(3,4)}$	\overline{CE} or \overline{OE} to Output Float	0	50	0	55	0	55	ns
t_{OH}	Output Hold from \overline{OE} , \overline{CE} or Address, whichever occurred first	0		0		0		ns

AC Read Waveforms (1, 2, 3, 4)

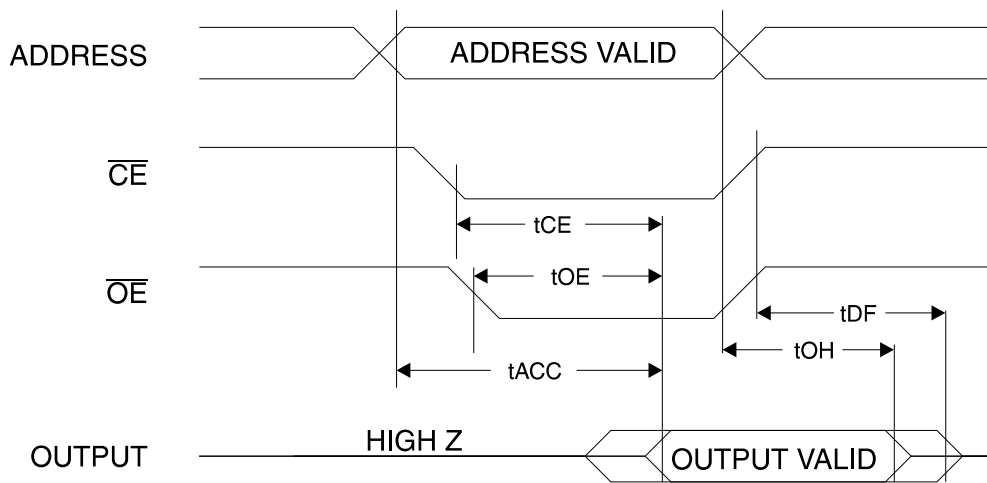

- Notes:
- \overline{CE} may be delayed up to $t_{ACC} - t_{CE}$ after the address transition without impact on t_{ACC} .
 - \overline{OE} may be delayed up to $t_{CE} - t_{OE}$ after the falling edge of \overline{CE} without impact on t_{CE} or by $t_{ACC} - t_{OE}$ after an address change without impact on t_{ACC} .

- t_{DF} is specified from \overline{OE} or \overline{CE} whichever occurs first ($C_L = 5 \text{ pF}$).
- This parameter is characterized and is not 100% tested.

Input Test Waveforms and Measurement Level

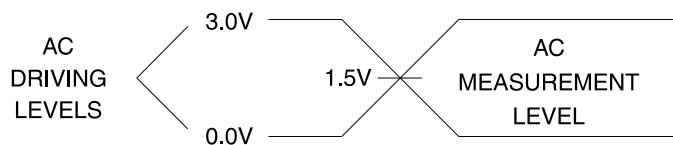

$t_R, t_F < 5 \text{ ns}$

Output Test Load

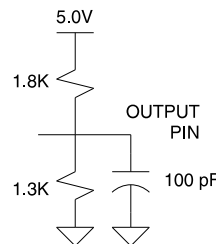

Pin Capacitance ($f = 1 \text{ MHz}, T = 25^\circ\text{C}$)⁽¹⁾

	Typ	Max	Units	Conditions
C_{IN}	4	10	pF	$V_{IN} = 0V$
C_{OUT}	8	12	pF	$V_{OUT} = 0V$

Note: 1. This parameter is characterized and is not 100% tested.

AC Write Characteristics

Symbol	Parameter	Min	Max	Units
t_{AS}, t_{OES}	Address, \overline{OE} Set-up Time	0		ns
t_{AH}	Address Hold Time	50		ns
t_{CS}	Chip Select Set-up Time	0		ns
t_{CH}	Chip Select Hold Time	0		ns
t_{WP}	Write Pulse Width (\overline{WE} or \overline{CE})	100		ns
t_{DS}	Data Set-up Time	50		ns
t_{DH}, t_{OEH}	Data, \overline{OE} Hold Time	0		ns

AC Write Waveforms

\overline{WE} Controlled

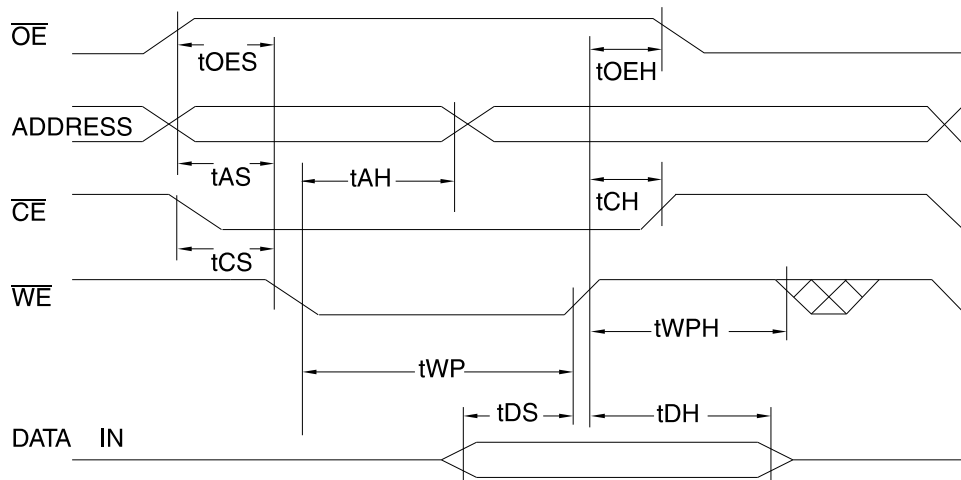

\overline{CE} Controlled

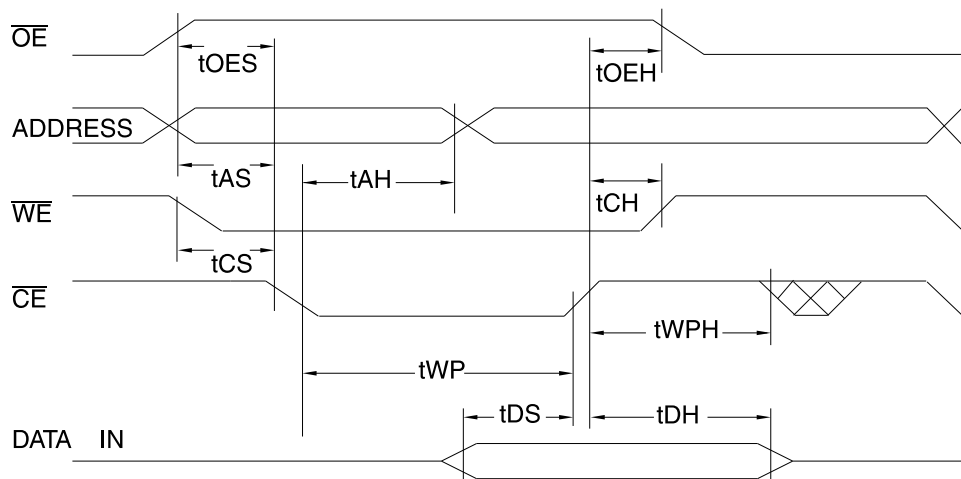

Page Mode Characteristics

Symbol	Parameter	Min	Max	Units
t _{WC}	Write Cycle Time		10	ms
t _{AS}	Address Set-up Time	0		ns
t _{AH}	Address Hold Time	50		ns
t _{DS}	Data Set-up Time	50		ns
t _{DH}	Data Hold Time	0		ns
t _{WP}	Write Pulse Width	100		ns
t _{BLC}	Byte Load Cycle Time		150	μs
t _{WPH}	Write Pulse Width High	50		ns

Page Mode Write Waveforms (1, 2)

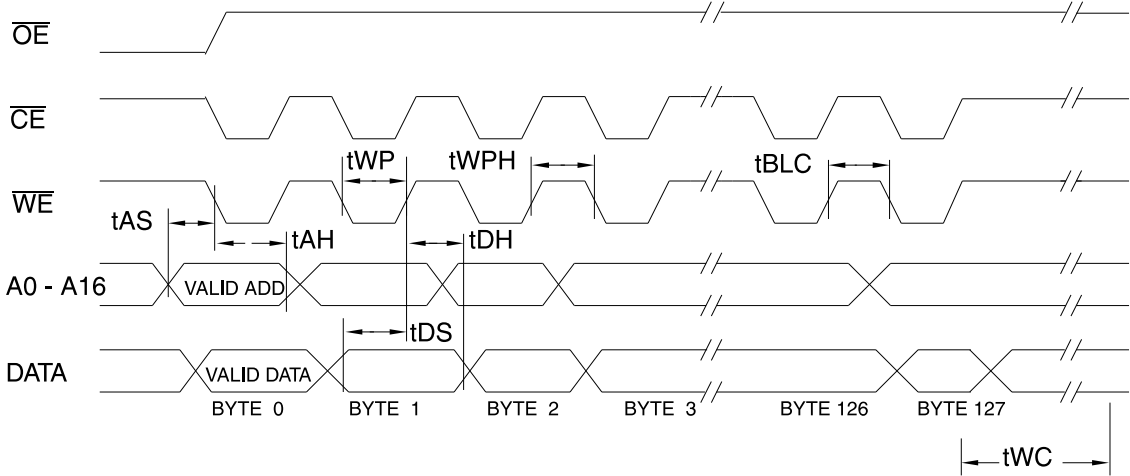

- Notes: 1. A7 through A16 must specify the page address during each high to low transition of \overline{WE} (or \overline{CE}).
- 2. \overline{OE} must be high only when \overline{WE} and \overline{CE} are both low.

Chip Erase Waveforms

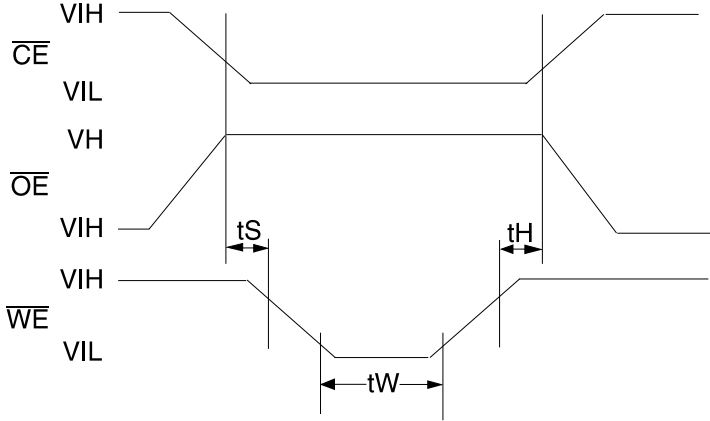

t_S = 5 μsec (min.)
 t_W = t_H = 10 msec (min.)
 V_H = 12.0V ± 0.5V



Software Data Protection Enable Algorithm ⁽¹⁾

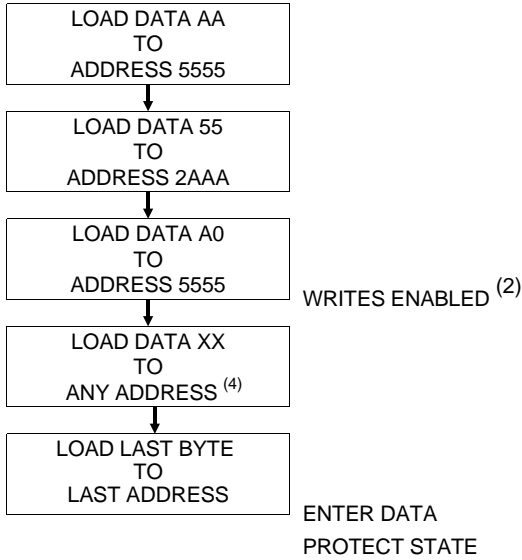

Software Data Protection Disable Algorithm ⁽¹⁾

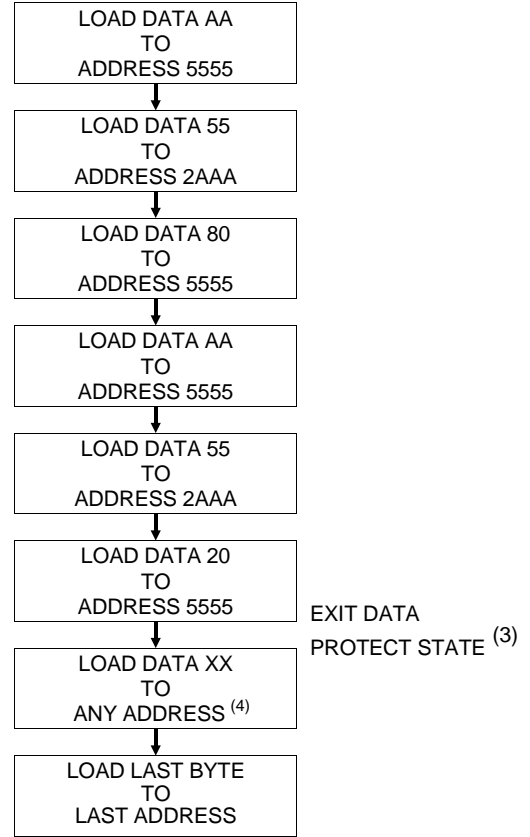

Notes:

1. Data Format: I/O7 - I/O0 (Hex); Address Format: A14 - A0 (Hex).
2. Write Protect state will be activated at end of write even if no other data is loaded.
3. Write Protect state will be deactivated at end of write period even if no other data is loaded.
4. 1 to 128-bytes of data are loaded.

Software Protected Program Cycle Waveform ^(1, 2, 3)

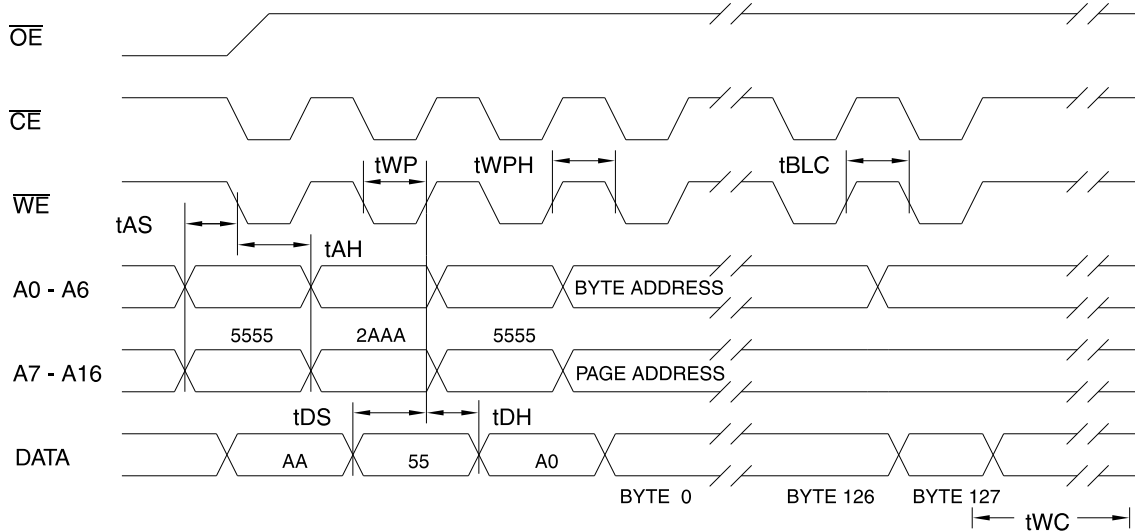

1. A0 - A14 must conform to the addressing sequence for the first 3-bytes as shown above.
2. After the command sequence has been issued and a page write operation follows, the page address inputs (A7 - A16) must be the same for each high to low transition of WE (or CE).
3. \overline{OE} must be high only when \overline{WE} and \overline{CE} are both low.

Data Polling Characteristics ⁽¹⁾

Symbol	Parameter	Min	Typ	Max	Units
t _{DH}	Data Hold Time	10			ns
t _{OE\bar{H}}	\overline{OE} Hold Time	10			ns
t _{OE}	\overline{OE} to Output Delay ⁽²⁾				ns
t _{WR}	Write Recovery Time	0			ns

Notes: 1. These parameters are characterized and not 100% tested. 2. See AC Read Characteristics.

Data Polling Waveforms

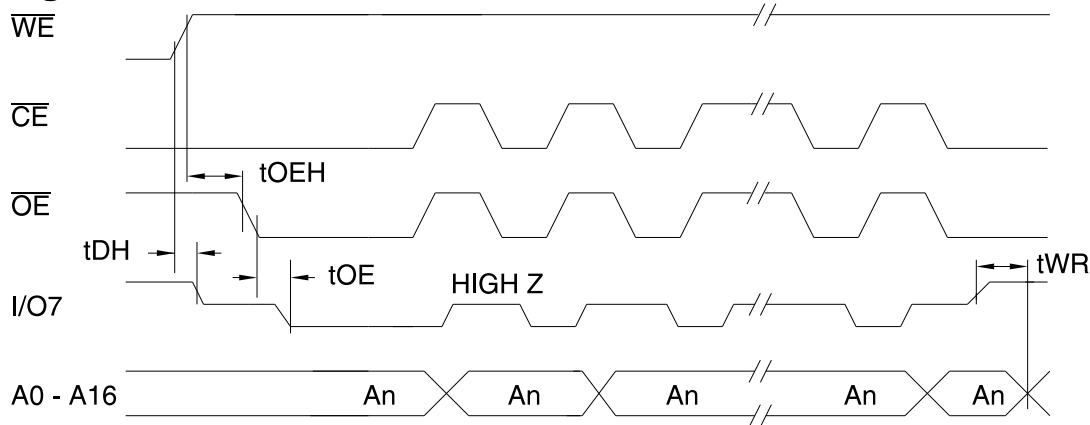

Toggle Bit Characteristics ⁽¹⁾

Symbol	Parameter	Min	Typ	Max	Units
t _{DH}	Data Hold Time	10			ns
t _{OE\bar{H}}	\overline{OE} Hold Time	10			ns
t _{OE}	\overline{OE} to Output Delay ⁽²⁾				ns
t _{OEHP}	\overline{OE} High Pulse	150			ns
t _{WR}	Write Recovery Time	0			ns

Notes: 1. These parameters are characterized and not 100% tested. 2. See AC Read Characteristics.

Toggle Bit Waveforms

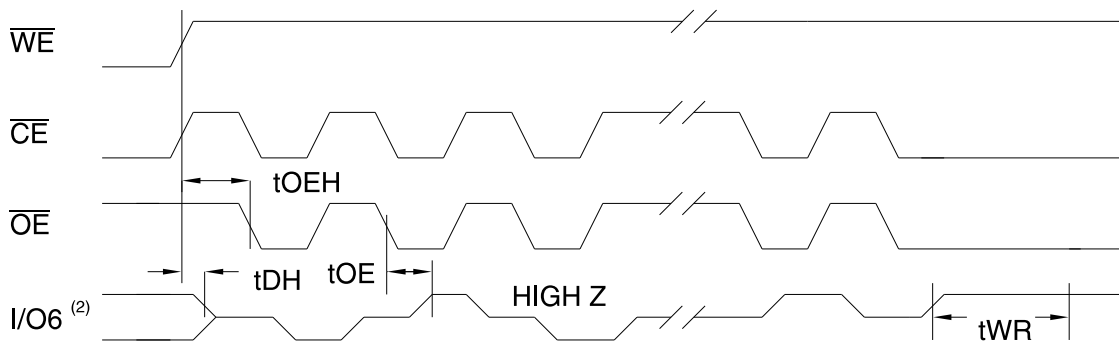

Notes: 1. Toggling either \overline{OE} or \overline{CE} or both \overline{OE} and \overline{CE} will operate toggle bit.
2. Beginning and ending state of $I/O6$ will vary.

3. Any address location may be used but the address should not vary.



Ordering Information ⁽¹⁾

t _{ACC} (ns)	I _{CC} (mA)		Ordering Code	Package	Operation Range
	Active	Standby			
120	40	0.2	AT28C010(E)-12JC AT28C010(E)-12PC AT28C010(E)-12TC	32J 32P6 32T	Commercial (0° to 70°C)
	40	0.2	AT28C010(E)-12JI AT28C010(E)-12PI AT28C010(E)-12TI	32J 32P6 32T	Industrial (-40° to 85°C)
150	40	0.2	AT28C010(E)-15JC AT28C010(E)-15PC AT28C010(E)-15TC	32J 32P6 32T	Commercial (0° to 70°C)
	40	0.2	AT28C010(E)-15JI AT28C010(E)-15PI AT28C010(E)-15TI	32J 32P6 32T	Industrial (-40° to 85°C)
200	40	0.2	AT28C010(E)-20JC AT28C010(E)-20PC AT28C010(E)-20TC	32J 32P6 32T	Commercial (0° to 70°C)
	40	0.2	AT28C010(E)-20JI AT28C010(E)-20PI AT28C010(E)-20TI	32J 32P6 32T	Industrial (-40° to 85°C)
	40	0.2	AT28C010-W	DIE	Commercial (0° to 70°C)

Note: 1. See Valid Part Number table below.

Valid Part Numbers

The following table lists standard Atmel products that can be ordered.

Device Numbers	Speed	Package and Temperature Combinations
AT28C010	12	JC, JI, PC, PI, TC, TI
AT28C010E	12	JC, JI, PC, PI, TC, TI
AT28C010	15	JC, JI, PC, PI, TC, TI
AT28C010E	15	JC, JI, PC, PI, TC, TI
AT28C010	20	JC, JI, PC, PI, TC, TI
AT28C010E	20	JC, JI, PC, PI, TC, TI
AT28C010	-	W

Package Type	
32J	32 Lead, Plastic J-Leaded Chip Carrier (PLCC)
32P6	32 Lead, 0.600" Wide, Plastic Dual Inline Package (PDIP)
32T	32 Lead, Plastic Thin Small Outline Package (TSOP)
W	DIE
Options	
Blank	Standard Device: Endurance = 10K Write Cycles; Write Time = 10 ms
E	High Endurance Option: Endurance = 100K Write Cycles

