

5348

SMOKE DETECTOR WITH INTERCONNECT AND TIMER

The A5348CA is a low-current, CMOS circuit providing all of the required features for an ionization-type smoke detector. A networking capability allows as many as 125 units to be interconnected so that if any unit senses smoke, all units will sound an alarm. In addition, special features are incorporated to facilitate alignment and test of the finished smoke detector. This device is designed to comply with Underwriters Laboratories Specification UL217.

The internal oscillator and timing circuitry keeps standby power to a minimum by powering down the device for 1.66 seconds and sensing smoke for only 10 ms. Every 24 on/off cycles, a check is made for low battery condition. By substituting other types of sensors, or a switch for the ionization detector, this very-low power device can be used in numerous other battery-operated safety/security applications.

The A5348CA is supplied in a low-cost, 16-pin dual in-line plastic package. It is rated for continuous operation over the temperature range of 0°C to +50°C.

FEATURES

- Interconnect Up to 125 Detectors
- Piezoelectric Horn Driver
- Guard Outputs for Detector Input
- Pulse Testing for Low Battery
- Power-ON Reset
- Internal Reverse Battery Protection
- Internal Timer & Control for Reduced Sensitivity
- Built-In Hysteresis Reduces False Triggering

ABSOLUTE MAXIMUM RATINGS (Voltages are referenced to V_{SS})

Supply Voltage Range,

V_{DD} -0.5 V to +15 V

Reverse Battery (10.5 V) 20 s

Input Voltage Range,

V_{IN} -0.3 V to $V_{DD} + 0.3$ V

Input Current, I_{IN} 10 mA

Operating Temperature Range,

T_A 0°C to +50°C

Storage Temperature Range,

T_S -55°C to +125°C

CAUTION: CMOS devices have input static protection but are susceptible to damage when exposed to extremely high static electrical charges.

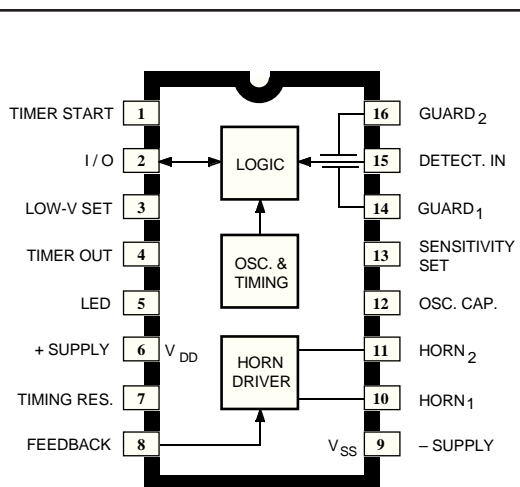

Dwg. PC-004

Always order by complete part number: **A5348CA**.

5348 SMOKE DETECTOR with INTERCONNECT and TIMER

FUNCTIONAL BLOCK DIAGRAM AND TYPICAL APPLICATION

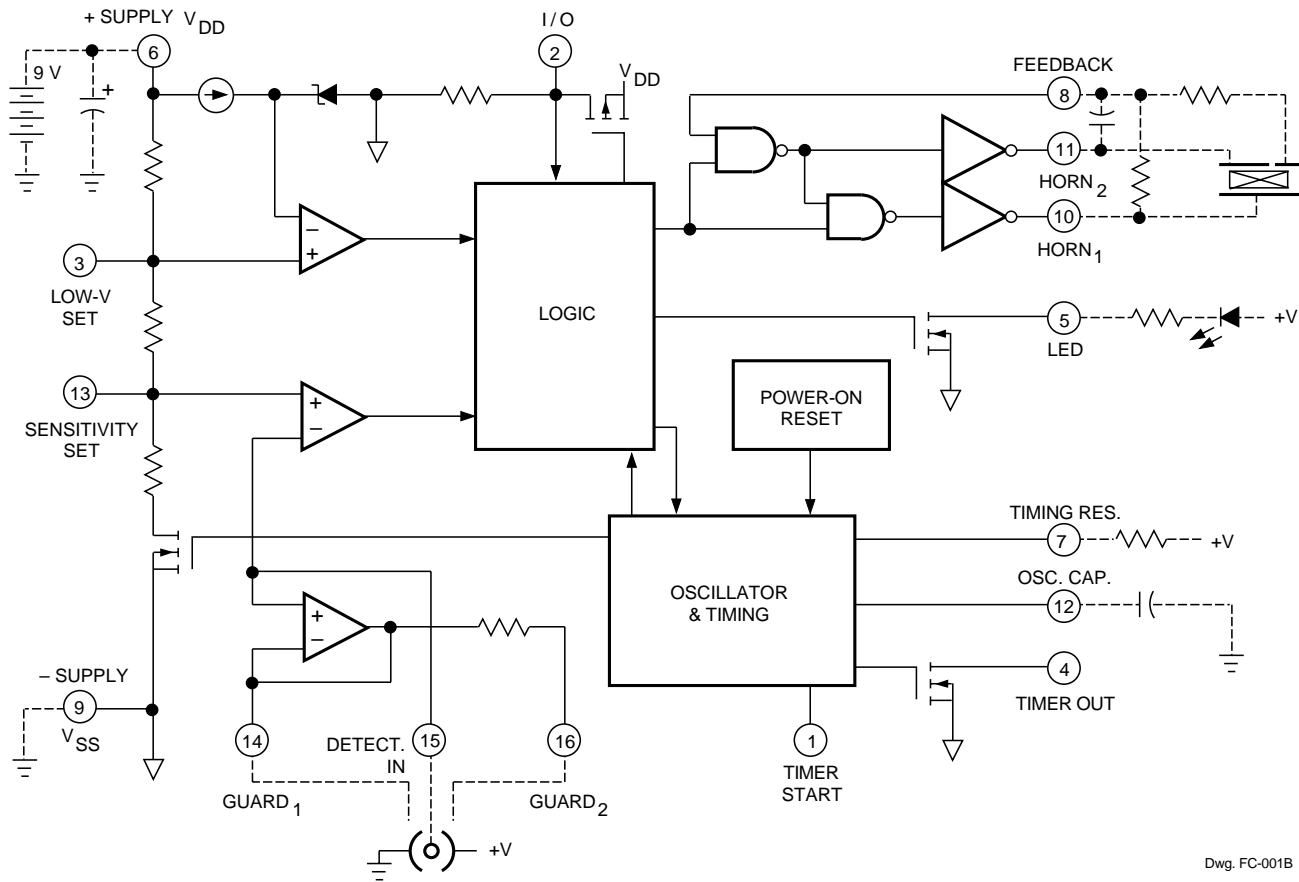

Dwg. FC-001B

5348
SMOKE DETECTOR
with INTERCONNECT
and TIMER

ELECTRICAL CHARACTERISTICS at $T_A = +25^\circ\text{C}$, $V_{DD} = 9.0\text{ V}$, $V_{SS} = 0\text{ V}$, $C_{12} = 0.1\ \mu\text{F}$,
 $R_7 = 8.2\ \text{M}\Omega$ (unless otherwise noted).

Characteristic	Test Pin	Test Conditions	Limits			
			Min.	Typ.	Max.	Units
Supply Voltage Range	6	Operating	6.0	9.0	12	V
Detector Input Current	15	0 to 40% RH, $V_{IN} = 0$ to 9.0 V	—	—	± 1.0	pA
Input Offset Voltage	14-15	Active Guard	—	—	± 100	mV
	16-15	Active Guard	—	—	± 100	mV
	15-13	Detect Comparator	—	—	± 50	mV
Hysteresis	13	No Alarm to Alarm	90	130	170	mV
Common Mode Range	14-15	Guard Amplifier	2.0	—	$V_{DD} - 0.5$	V
	13-15	Smoke Comparator	0.5	—	$V_{DD} - 2.0$	V
Active Guard Impedance	14	to V_{SS}	—	10	—	k Ω
	16	to V_{SS}	—	500	—	k Ω
Oscillator Period	12	No Alarm	1.34	1.67	2.00	s
		Alarm	32	40	48	ms
Oscillator Pulse Width	4		8.0	10	12	ms
Timer Period	4	After Pin 1 High-to-Low, No Smoke	8.0	10	12	min
Low Voltage Threshold	6	$T_A = 0$ to 50°C	7.2	—	7.8	V
Sensitivity Adj. Voltage	13	V_{13}/V_{DD} , pin 13 open circuit	48.5	50	51.5	%
Horn Output Voltage	10-11	$I_{OUT} = 16\ \text{mA}$, $V_{DD} = 9.0\ \text{V}$	—	0.1	0.5	V
		$I_{OUT} = 16\ \text{mA}$, $V_{DD} = 7.2\ \text{V}$	—	—	0.9	V
		$I_{OUT} = -16\ \text{mA}$, $V_{DD} = 9.0\ \text{V}$	8.5	8.8	—	V
		$I_{OUT} = -16\ \text{mA}$, $V_{DD} = 7.2\ \text{V}$	6.3	—	—	V
Horn Output ON Time	10-11	Alarm	120	160	208	ms
		Low Battery	8.0	10	12	ms
Horn Output OFF Time	10-11	Alarm	60	80	104	ms
		Low Battery	32	40	48	s
Timer Start Logic Levels	1	V_{IH}	3.5	—	—	V
		V_{IL}	—	—	1.5	V
Timer Start Input Current	1	$V_{IN} = 9.0\ \text{V}$	20	—	80	μA

Continued next page . . .

NOTE 1: Negative current is defined as coming out of (sourcing) the specified device pin.

NOTE 2: Alarm (Smoke) Condition is defined as $V_{15} < V_{13}$; No Alarm (No Smoke) Condition as $V_{15} > V_{13}$.

5348

SMOKE DETECTOR

with INTERCONNECT

and TIMER

ELECTRICAL CHARACTERISTICS continued

Characteristic	Test Pin	Test Conditions	Limits			
			Min.	Typ.	Max.	Units
Timer Out Output Current	4	$V_{OUT} = 0.5 \text{ V}$	500	—	—	μA
LED Output ON Current	5	$V_{DD} = 7.2 \text{ V}, V_{OUT} = 1.0 \text{ V}$	10	—	—	mA
LED Output ON Time	5		8.0	10	12	ms
LED Output OFF Time	5	No Alarm, In Standby	32	40	48	s
		No Alarm, Timer Mode After Pin 1 High-to-Low	8.0	10	12	s
I/O Current	2	No Alarm, $V_{I/O} = V_{DD} - 2.0 \text{ V}$	25	—	60	μA
		Alarm, $V_{I/O} = V_{DD} - 2.0 \text{ V}$	-7.5	—	—	mA
I/O Alarm Voltage	2	External "Alarm" In	3.0	—	—	V
I/O Delay	2	"Alarm" Out	—	3.0	—	s
Supply Current	6	$V_{DD} = 9.0 \text{ V}$, No Alarm, No Loads	—	5.0	9.0	μA
		$V_{DD} = 12 \text{ V}$, No Alarm, No Loads	—	—	12	μA

NOTE 1: Negative current is defined as coming out of (sourcing) the specified device pin.

NOTE 2: Alarm (Smoke) Condition is defined as $V_{15} < V_{13}$; No Alarm (No Smoke) Condition as $V_{15} > V_{13}$.

CIRCUIT DESCRIPTION

The A5348CA is a low-current CMOS circuit providing all of the required features for an ionization-type smoke detector.

Oscillator. An internal oscillator operates with a period of 1.67 seconds during no-smoke conditions. Every 1.67 seconds, internal power is applied to the entire circuit and a check is made for smoke. Every 24 clock cycles (40 seconds), the LED is pulsed and a check is made for low battery by comparing V_{DD} to an internal reference. Since very-low currents are used in the device, the oscillator capacitor at pin 12 should be a low-leakage type (PTFE, polystyrene, or polypropylene).

Detector Circuitry. When smoke is detected, the resistor divider network that sets the sensitivity (smoke trip point) is altered to increase the sensitivity set voltage (pin 13) by typically 130 mV with no external connections to pins 3 or 13. This provides hysteresis and reduces false triggering. An active guard is provided on both pins adjacent to the detector input (pin 15). The voltage at pins 14 and 16 will be within 100 mV of the input. This will keep surface leakage currents to a minimum and provide a method of measuring the input voltage without loading the ionization chamber. The active guard amplifier is not power strobed and thus provides constant protection from surface leakage currents. The detector input has internal diode protection against static damage.

Alarm Circuitry. If smoke is detected, the oscillator period changes to 40 ms and the horn is enabled. The horn output is typically 160 ms ON, 80 ms OFF. During the OFF time, smoke is again checked and will inhibit further alarm output if smoke is not sensed. During smoke conditions the low battery alarm is inhibited and the LED is driven at a 1 Hz rate.

5348 SMOKE DETECTOR with INTERCONNECT and TIMER

Sensitivity Adjust. The detector sensitivity to smoke is set internally by a voltage divider connected between V_{DD} and V_{SS} . The sensitivity can be externally adjusted to the individual characteristics of the ionization chamber by connecting a resistor between pin 13 and V_{DD} , or between pin 13 and V_{SS} .

Low Battery. The low battery threshold is set internally by a voltage divider connected between V_{DD} and V_{SS} . The threshold can be increased by connecting a resistor between pin 3 and V_{DD} . The threshold can be decreased by connecting a resistor between pin 3 and V_{SS} . The battery voltage level is checked every 40 seconds during the 10 mA, 10 ms LED pulse. If an LED is not used, it should be replaced with an equivalent resistor (typically 500 Ω to 1000 Ω) such that the battery loading remains at 10 mA.

Timer. An internal timer is provided that can be used in various configurations to allow for a period of reduced smoke detector sensitivity ("hush"). When a high-to-low transition occurs at pin 1, the internal timer is reset, the timer mode enabled, and the circuit reset to a no alarm condition. The LED will flash at a 10 second rate. If the level of smoke is increased such that the reduced sensitivity level is reached, the device will go into the alarm condition. The timer, however, will continue to completion of the nominal 10-1/4 minute period (368 clock cycles). If the timer mode is not used, pin 1 should be tied low.

I/O. A connection is provided at pin 2 to allow multiple smoke detectors to be commoned. If any single unit detects smoke (I/O is driven high), all connected units will sound their associated horns after a nominal 3 second delay. The LED is suppressed when an alarm is signaled from an interconnected unit.

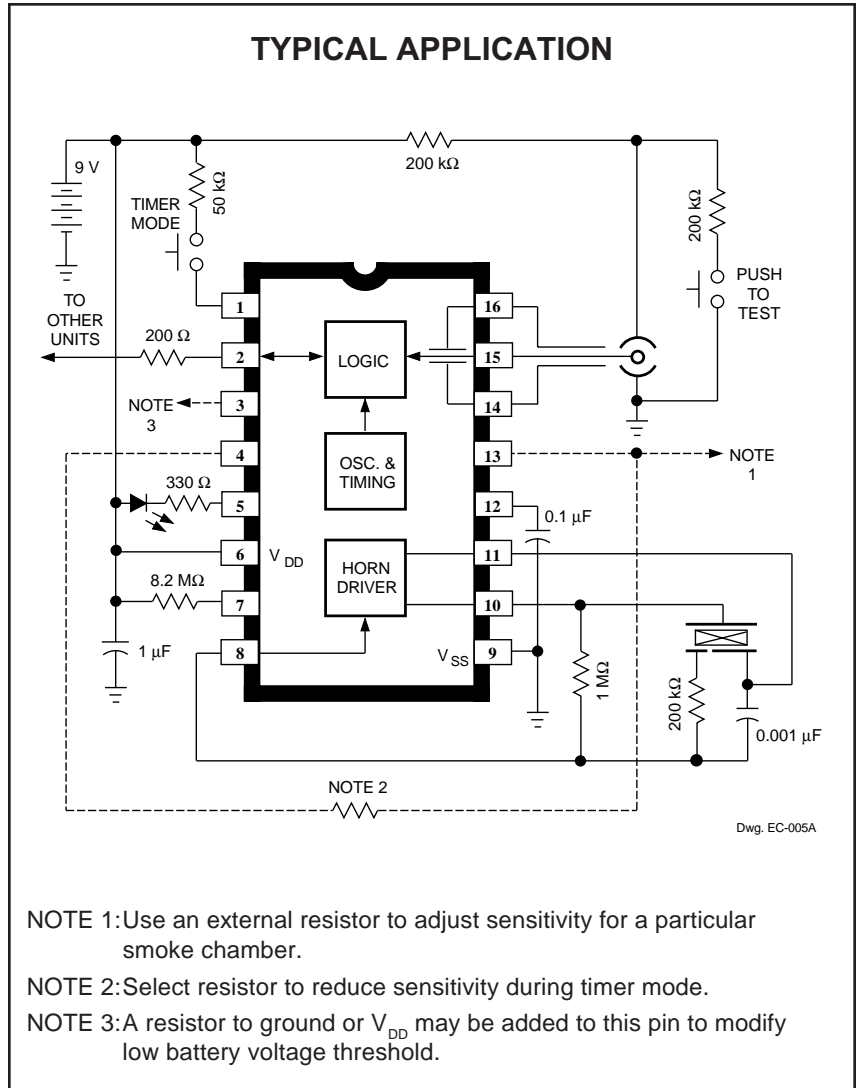

Testing. On power up, all internal counters are reset. Internal test circuitry allows for low battery check by holding pins 8 and 12 low during power up, then reducing V_{DD} and monitoring HORN₁ (pin 10). All functional tests can be accelerated by driving pin 12 with a 2 kHz square wave. The 10 ms strobe period must be maintained for proper operation of the comparator circuitry.

5348 SMOKE DETECTOR with INTERCONNECT and TIMER

TIMING DIAGRAMS IN TYPICAL APPLICATION

NON-TIMER MODE

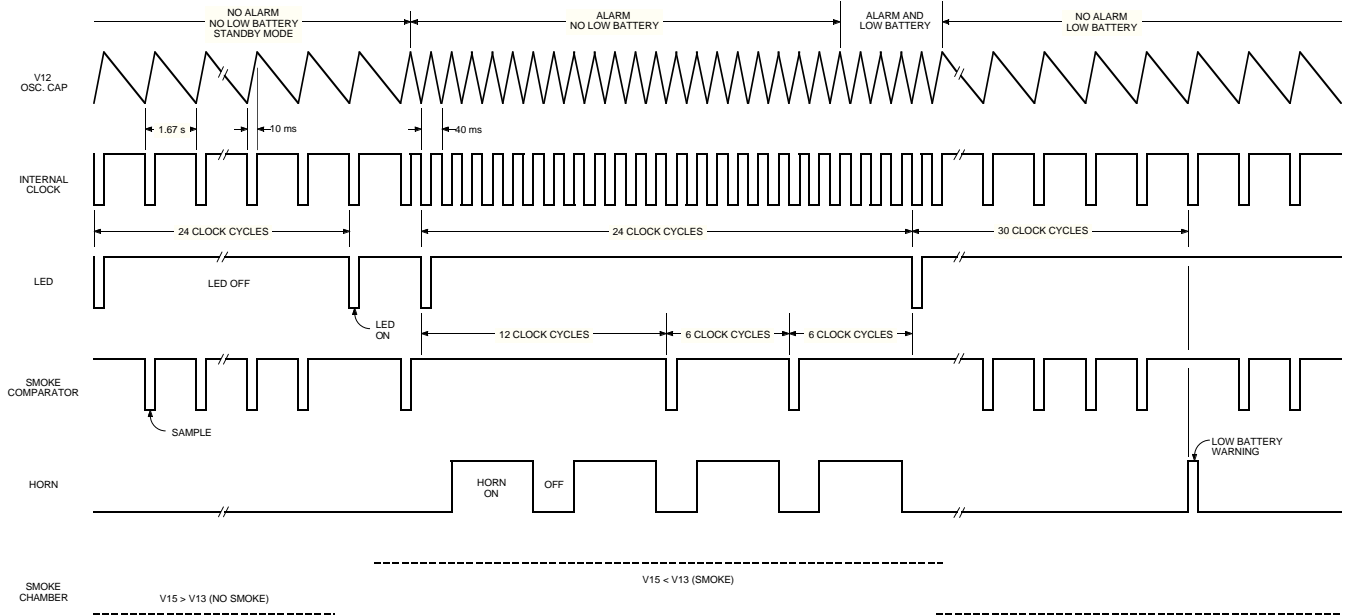

Dwg. WC-003

TIMER MODE

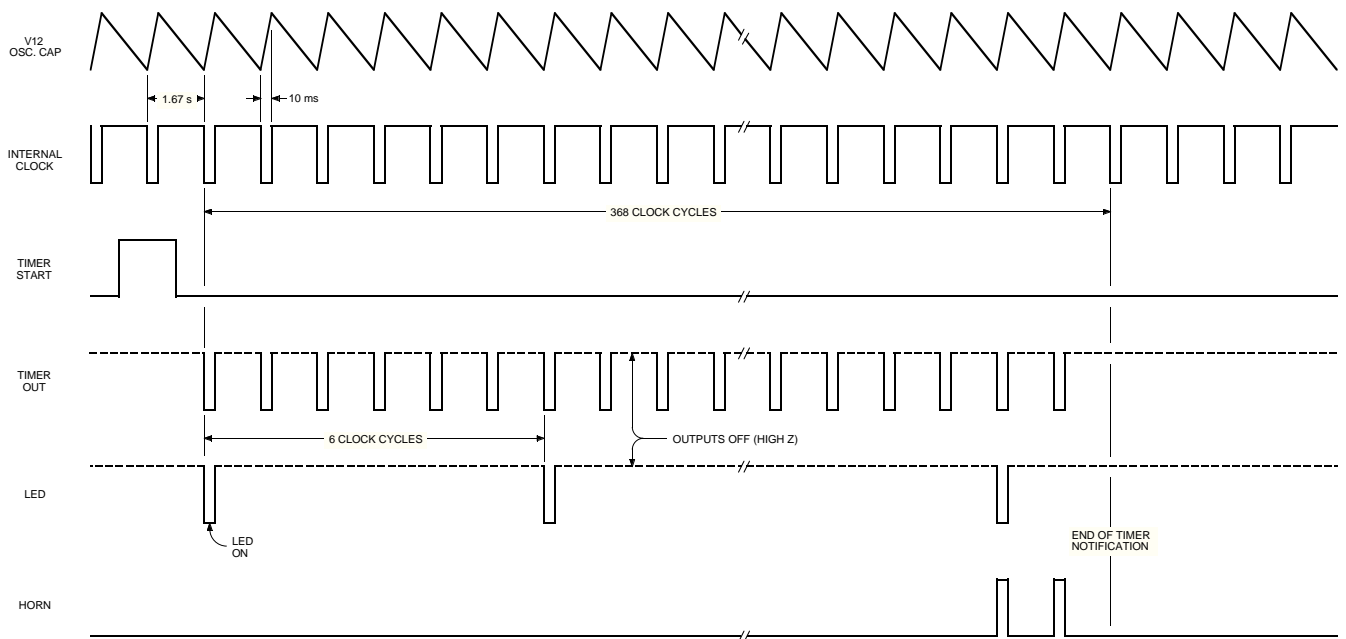

Dwg. WC-005

5348
SMOKE DETECTOR
with INTERCONNECT
and TIMER

I/O OPERATION

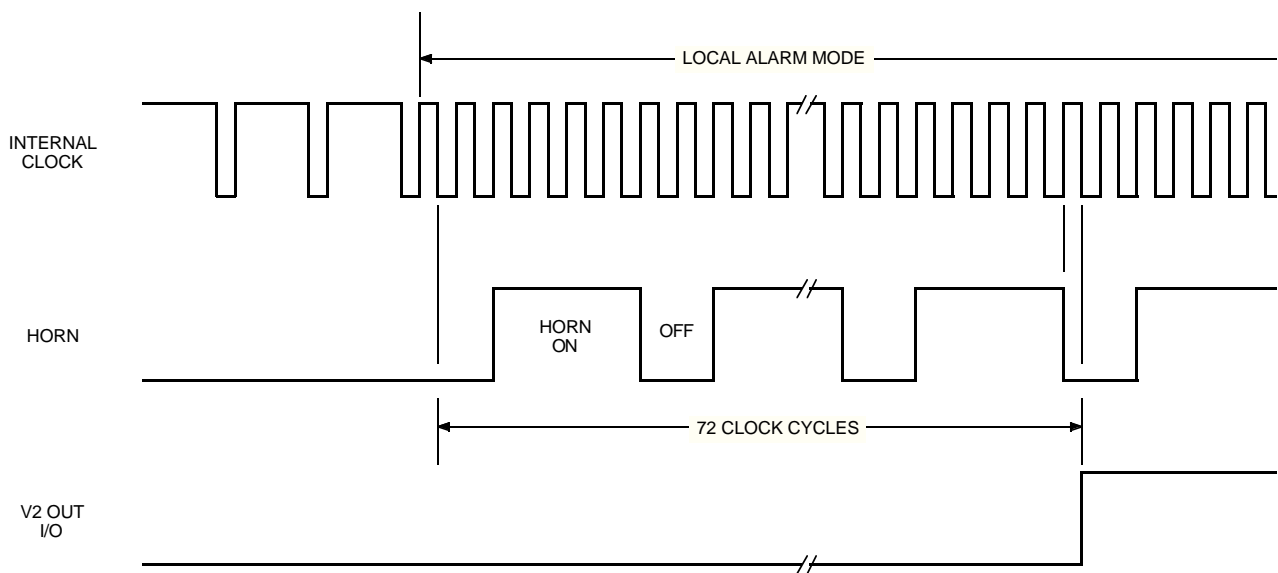
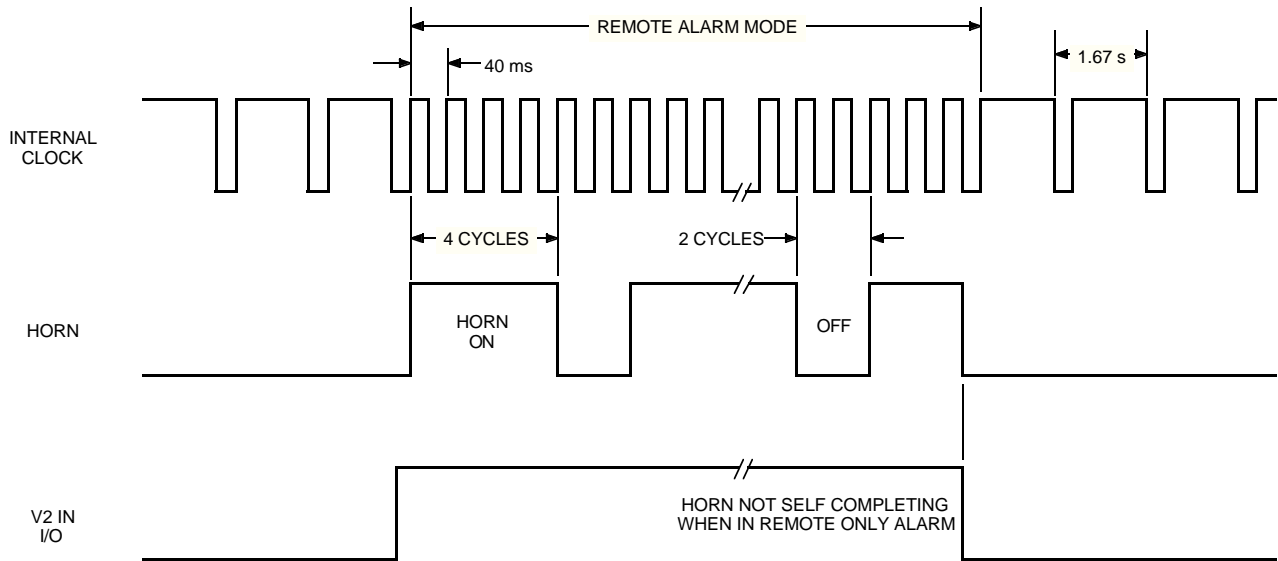

5348 SMOKE DETECTOR with INTERCONNECT and TIMER

Dimensions in Inches (controlling dimensions)

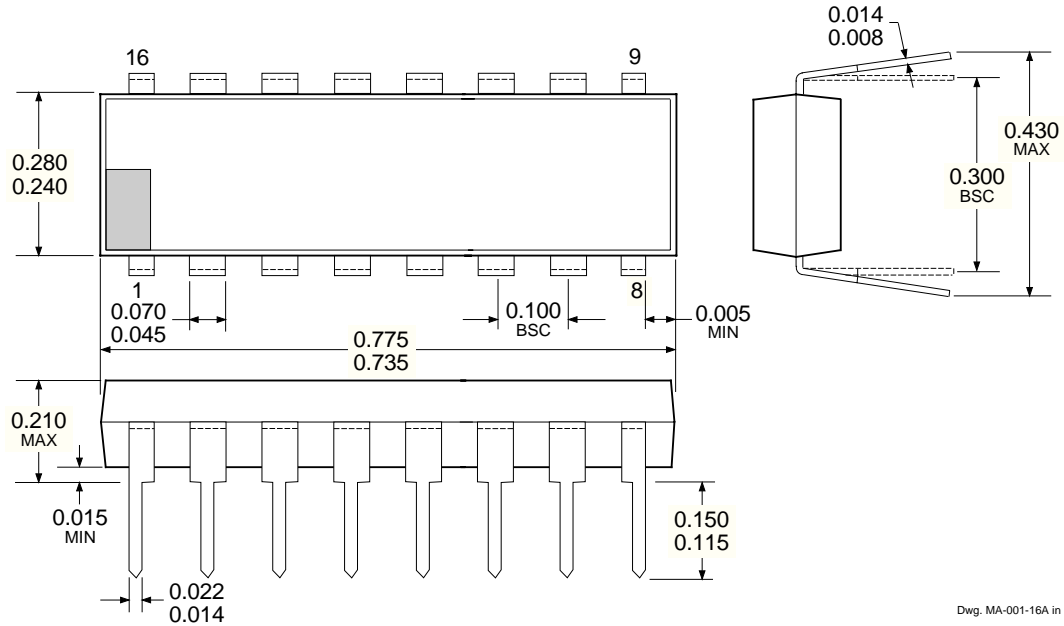

Dimensions in Millimeters (for reference only)

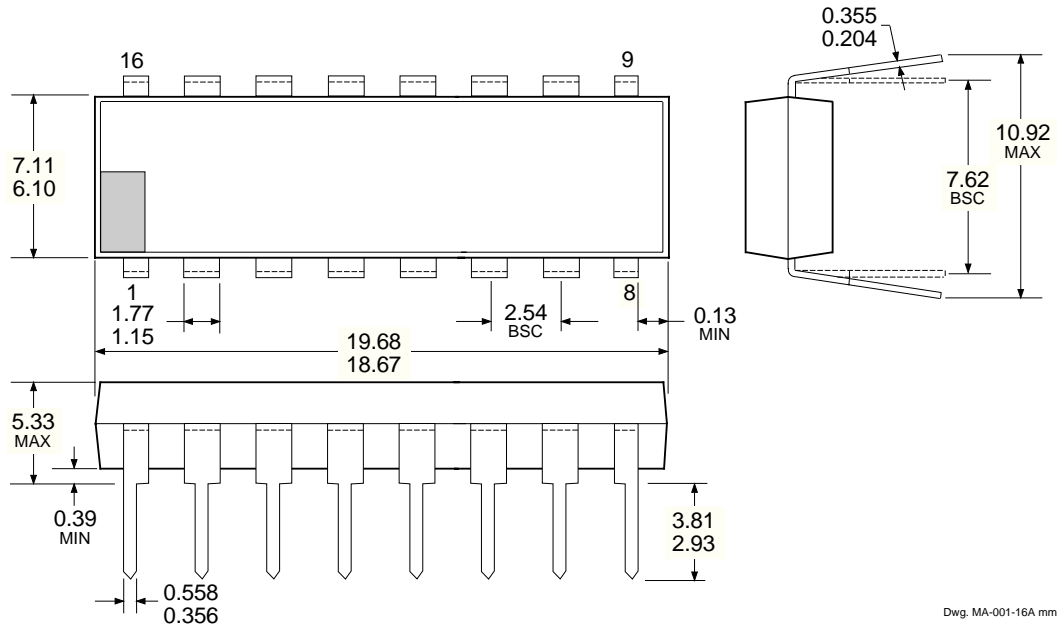

- NOTES:
1. Lead thickness is measured at seating plane or below.
 2. Lead spacing tolerance is non-cumulative.
 3. Exact body and lead configuration at vendor's option within limits shown.

Allegro MicroSystems, Inc. reserves the right to make, from time to time, such departures from the detail specifications as may be required to permit improvements in the design of its products.
The information included herein is believed to be accurate and reliable. However, Allegro MicroSystems, Inc. assumes no responsibility for its use; nor for any infringements of patents or other rights of third parties which may result from its use.