

54F219,74F219

54F219 74F219 64-Bit Random Access Memory with TRI-STATE(RM) Outputs



Literature Number: SNOS173A

54F/74F219 64-Bit Random Access Memory with TRI-STATE® Outputs

General Description

The 'F219 is a high-speed 64-bit RAM organized as a 16-word by 4-bit array. Address inputs are buffered to minimize loading and are fully decoded on-chip. The outputs are TRI-STATE and are in the high-impedance state whenever the Chip Select (\overline{CS}) input is HIGH. The outputs are active only in the Read mode. This device is similar to the 'F189 but features non-inverting, rather than inverting, data outputs.

Features

- TRI-STATE outputs for data bus applications
- Buffered inputs minimize loading
- Address decoding on-chip
- Diode clamped inputs minimize ringing
- Available in SOIC (300 mil only)

Commercial	Military	Package Number	Package Description
74F219PC		N16E	16-Lead (0.300" Wide) Molded Dual-In-Line
	54F219DL (Note 2)	J16A	16-Lead Ceramic Dual-In-Line
74F219SC (Note 1)		M16B	16-Lead (0.300" Wide) Molded Small Outline, JEDEC
74F219SJ (Note 1)		M16D	16-Lead (0.300" Wide) Molded Small Outline, EIAJ
	54F219FL (Note 2)	W16A	16-Lead Cerpack
	54F219LL (Note 2)	E20A	20-Lead Ceramic Leadless Chip Carrier, Type C

Note 1: Devices also available in 13" reel. Use suffix = SCX and SJX.

Note 2: Military grade device with environmental and burn-in processing. Use suffix = DLQB, FLQB and LLQB.

Logic Symbol

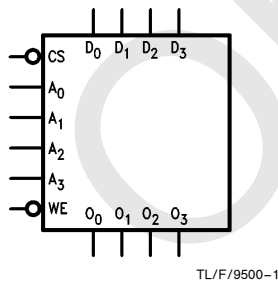

Connection Diagrams

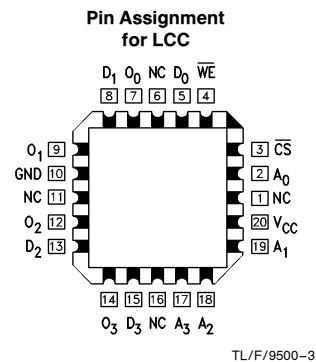
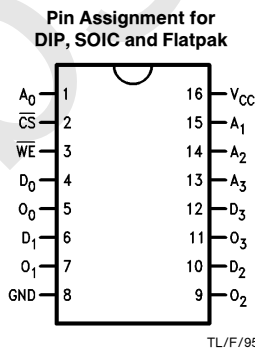

TRI-STATE® is a registered trademark of National Semiconductor Corporation.

Unit Loading/Fan Out

Pin Names	Description	54F/74F	
		U.L. HIGH/LOW	Input I_{IH}/I_{IL} Output I_{OH}/I_{OL}
A_0-A_3	Address Inputs	1.0/1.0	$20 \mu A / -0.6 \text{ mA}$
\overline{CS}	Chip Select Input (Active LOW)	1.0/2.0	$20 \mu A / -1.2 \text{ mA}$
\overline{WE}	Write Enable Input (Active LOW)	1.0/1.0	$20 \mu A / -0.6 \text{ mA}$
D_0-D_3	Data Inputs	1.0/1.0	$20 \mu A / -0.6 \text{ mA}$
O_0-O_3	TRI-STATE Data Outputs	150/40 (33.3)	$-3 \text{ mA} / 24 \text{ mA} (20 \text{ mA})$

Function Table

Inputs		Operation	Condition of Outputs
\overline{CS}	\overline{WE}		
L	L	Write	High Impedance
L	H	Read	True Stored Data
H	X	Inhibit	High Impedance

H = HIGH Voltage Level
L = LOW Voltage Level
X = Immaterial

Block Diagram

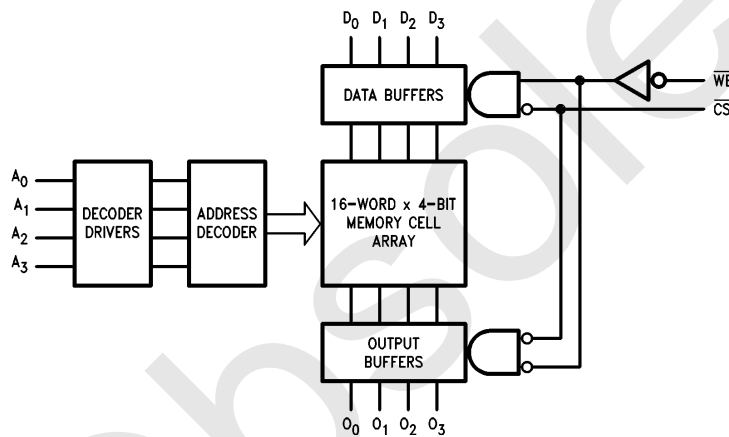

TL/F/9500-4

Absolute Maximum Ratings (Note 1)

If Military/Aerospace specified devices are required, please contact the National Semiconductor Sales Office/Distributors for availability and specifications.

Storage Temperature	-65°C to +150°C
Ambient Temperature under Bias	-55°C to +125°C
Junction Temperature under Bias	-55°C to +175°C
Plastic	-55°C to +150°C
V _{CC} Pin Potential to Ground Pin	-0.5V to +7.0V
Input Voltage (Note 2)	-0.5V to +7.0V
Input Current (Note 2)	-30 mA to +5.0 mA
Voltage Applied to Output in HIGH State (with V _{CC} = 0V)	
Standard Output	-0.5V to V _{CC}
TRI-STATE Output	-0.5V to +5.5V

Current Applied to Output in LOW State (Max) twice the rated I_{OL} (mA)

Note 1: Absolute maximum ratings are values beyond which the device may be damaged or have its useful life impaired. Functional operation under these conditions is not implied.

Note 2: Either voltage limit or current limit is sufficient to protect inputs.

Recommended Operating Conditions

Free Air Ambient Temperature	
Military	-55°C to +100°C
Commercial	0°C to +70°C
Supply Voltage	
Military	+4.5V to +5.5V
Commercial	+4.5V to +5.5V

DC Electrical Characteristics

Symbol	Parameter		54F/74F			Units	V _{CC}	Conditions
			Min	Typ	Max			
V _{IH}	Input HIGH Voltage		2.0			V		Recognized as a HIGH Signal
V _{IL}	Input LOW Voltage		0.8			V		Recognized as a LOW Signal
V _{CD}	Input Clamp Diode Voltage		-1.2			V	Min	I _{IN} = -18 mA
V _{OH}	Output HIGH Voltage	54F 10% V _{CC}	2.5			V	Min	I _{OH} = -1 mA I _{OH} = -3 mA I _{OH} = -1 mA I _{OH} = -3 mA I _{OH} = -1 mA I _{OH} = -3 mA
		54F 10% V _{CC}	2.4					
		74F 10% V _{CC}	2.5					
		74F 10% V _{CC}	2.4					
		74F 5% V _{CC}	2.7					
		74F 5% V _{CC}	2.7					
V _{OL}	Output LOW Voltage	54F 10% V _{CC}	0.5			V	Min	I _{OL} = 20 mA I _{OL} = 24 mA
		74F 10% V _{CC}	0.5					
I _{IH}	Input HIGH Current	54F	20.0			μA	Max	V _{IN} = 2.7V
		74F	5.0					
I _{BVI}	Input HIGH Current Breakdown Test	54F	100			μA	Max	V _{IN} = 7.0V
		74F	7.0					
I _{CEX}	Output HIGH Leakage Current	54F	250			μA	Max	V _{OUT} = V _{CC}
		74F	50					
V _{ID}	Input Leakage Test	74F	4.75			V	0.0	I _{ID} = 1.9 μA All Other Pins Grounded
I _{OD}	Output Leakage Circuit Current	74F	3.75			μA	0.0	V _{IOD} = 150 mV All Other Pins Grounded
I _{IL}	Input LOW Current		-0.6 -1.2			mA	Max	V _{IN} = 0.5V (A _n , \overline{WE} , D _n) V _{IN} = 0.5V (CS)
I _{OZH}	Output Leakage Current		50			μA	Max	V _{OUT} = 2.7V
I _{OZL}	Output Leakage Current		-50			μA	Max	V _{OUT} = 0.5V
I _{OS}	Output Short-Circuit Current		-60 -150			mA	Max	V _{OUT} = 0V
I _{ZZ}	Bus Drainage Test		500			μA	0.0V	V _{OUT} = 5.25V
I _{CC}	Power Supply Current		37 55			mA	Max	

AC Electrical Characteristics

Symbol	Parameter	74F			54F		74F		Units
		$T_A = +25^\circ\text{C}$ $V_{CC} = +5.0\text{V}$ $C_L = 50\text{ pF}$			$T_A = +100^\circ\text{C}$ $V_{CC} = \text{Mil}$ $C_L = 50\text{ pF}$		$T_A, V_{CC} = \text{Com}$ $C_L = 50\text{ pF}$		
		Min	Typ	Max	Min	Max	Min	Max	
t_{PLH} t_{PHL}	Access Time, HIGH or LOW A_n to O_n	10.0 8.0	18.5 13.5	26.0 19.0	9.0 8.0	32.0 23.0	10.0 8.0	27.0 20.0	ns
t_{PZH} t_{PZL}	Access Time, HIGH or LOW \overline{CS} to O_n	3.5 5.0	6.0 9.0	8.5 13.0	3.5 5.0	10.5 15.0	3.5 5.0	9.5 14.0	ns
t_{PHZ} t_{PLZ}	Disable Time, HIGH or LOW \overline{CS} to O_n	2.0 3.0	4.0 5.5	6.0 8.0	2.0 2.5	8.0 10.0	2.0 3.0	7.0 9.0	ns
t_{PZH} t_{PZL}	Write Recovery Time HIGH or LOW, \overline{WE} to O_n	6.5 6.5	20.0 11.0	28.0 15.5	6.5 6.5	37.5 17.5	6.5 6.5	29.0 16.5	ns
t_{PHZ} t_{PLZ}	Disable Time, HIGH or LOW \overline{WE} to O_n	4.0 5.0	7.0 9.0	10.0 13.0	3.5 5.0	12.0 15.0	4.0 5.0	11.0 14.0	ns

AC Operating Requirements

Symbol	Parameter	74F		54F		74F		Units
		$T_A = +25^\circ\text{C}$ $V_{CC} = +5.0\text{V}$		$T_A = +100^\circ\text{C}$ $V_{CC} = \text{Mil}$		$T_A, V_{CC} = \text{Com}$		
		Min	Max	Min	Max	Min	Max	
$t_s(H)$ $t_s(L)$	Setup Time, HIGH or LOW A_n to \overline{WE}	0 0		0 0		0 0		ns
$t_h(H)$ $t_h(L)$	Hold Time, HIGH or LOW A_n to \overline{WE}	2.0 2.0		2.0 2.0		2.0 2.0		ns
$t_s(H)$ $t_s(L)$	Setup Time, HIGH or LOW D_n to \overline{WE}	10.0 10.0		11.0 11.0		10.0 10.0		ns
$t_h(H)$ $t_h(L)$	Hold Time, HIGH or LOW D_n to \overline{WE}	0 0		2.0 2.0		0 0		ns
$t_s(L)$	Setup Time, LOW \overline{CS} to \overline{WE}	0		0		0		ns
$t_h(L)$	Hold Time, LOW \overline{CS} to \overline{WE}	6.0		7.5		6.0		ns
$t_w(L)$	\overline{WE} Pulse Width, LOW	6.0		15.0		6.0		ns

Ordering Information

The device number is used to form part of a simplified purchasing code where the package type and temperature range are defined as follows:

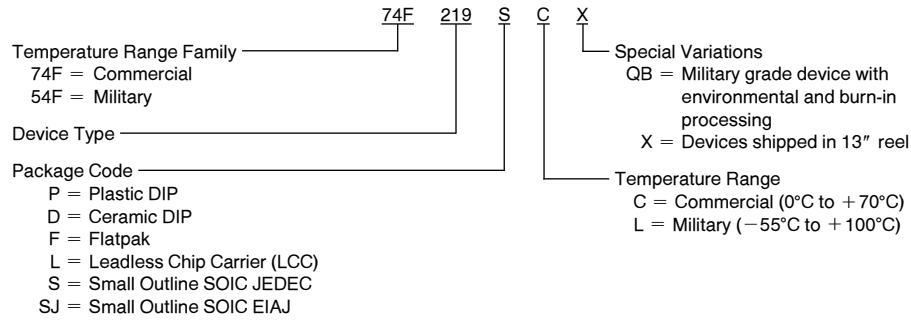

Physical Dimensions inches (millimeters)

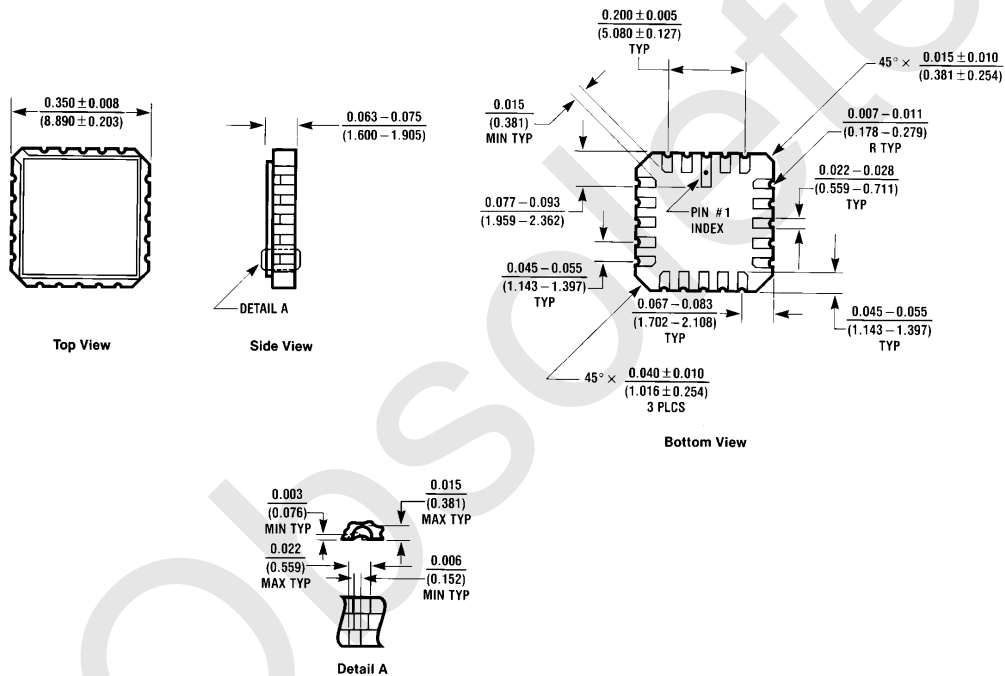

20-Lead Ceramic Leadless Chip Carrier (L)
NS Package Number E20A

E20A (REV D)

Physical Dimensions inches (millimeters) (Continued)

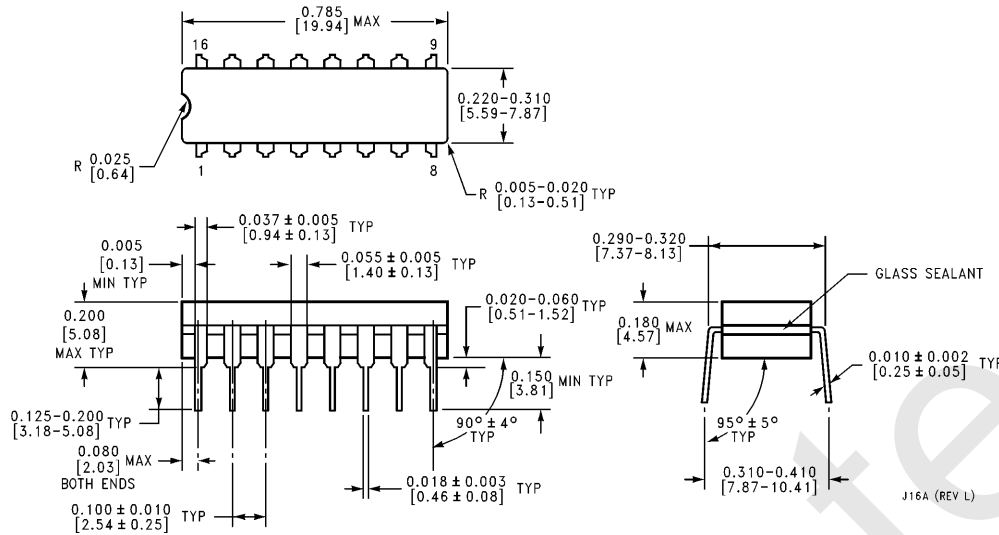

**16-Lead Ceramic Dual-In-Line Package (D)
NS Package Number J16A**

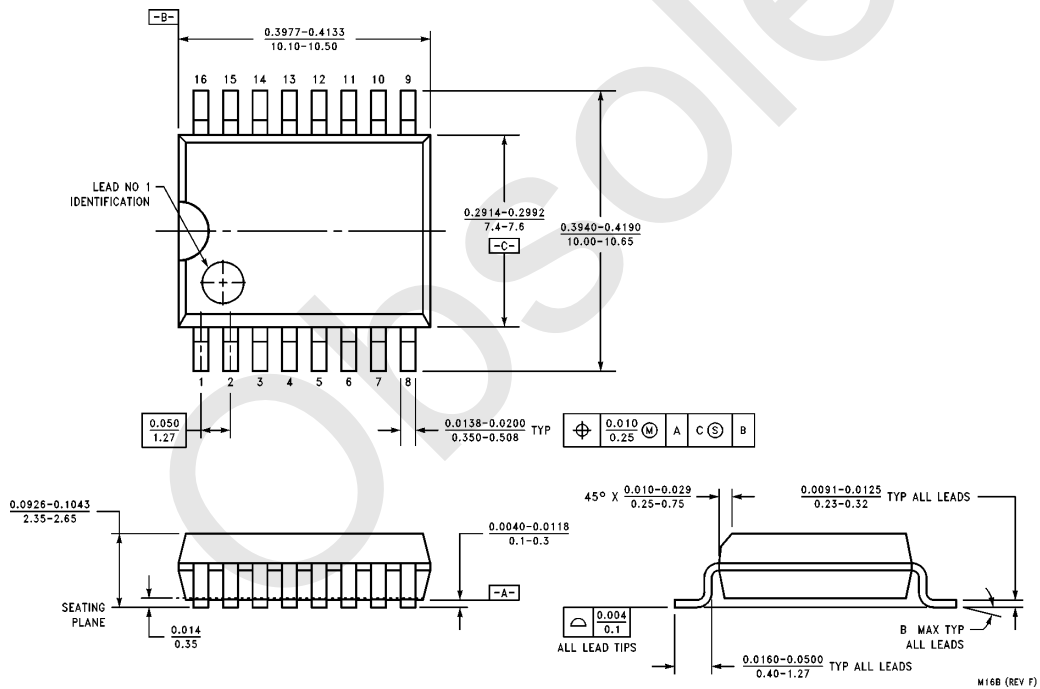

**16-Lead (0.300" Wide) Molded Small Outline Package, JEDEC (S)
NS Package Number M16B**

Physical Dimensions inches (millimeters) (Continued)

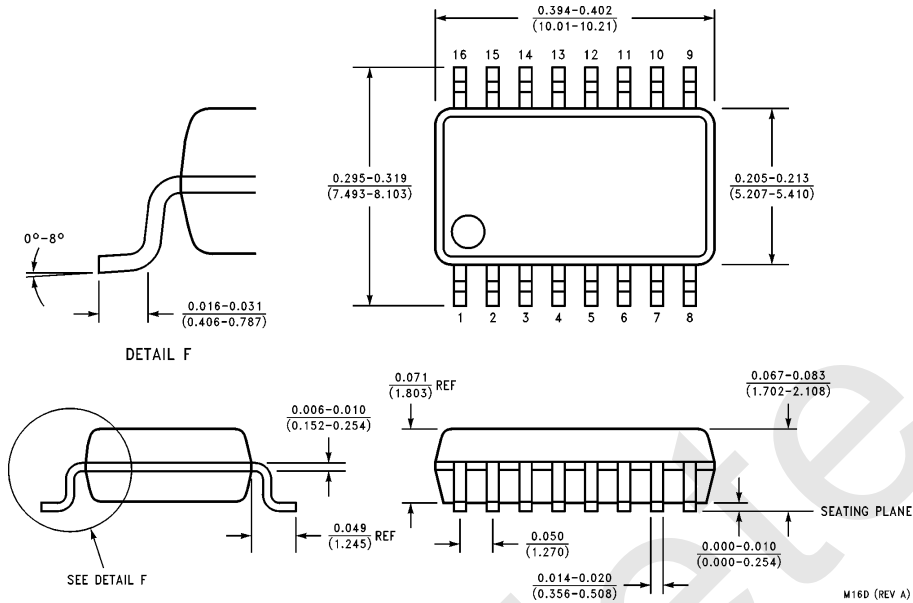

**16-Lead (0.300" Wide) Molded Small Outline Package, EIAJ (SJ)
NS Package Number M16D**

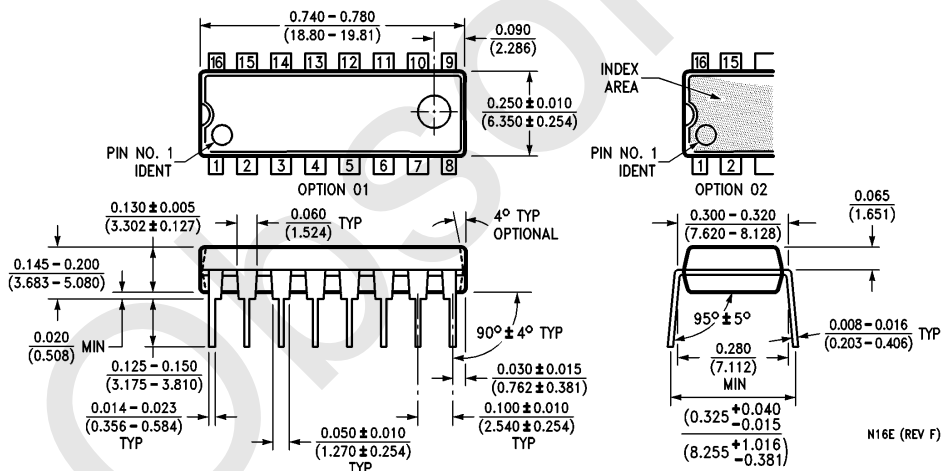

**16-Lead (0.300" Wide) Molded Dual-In-Line Package (P)
NS Package Number N16E**

Physical Dimensions inches (millimeters) (Continued)

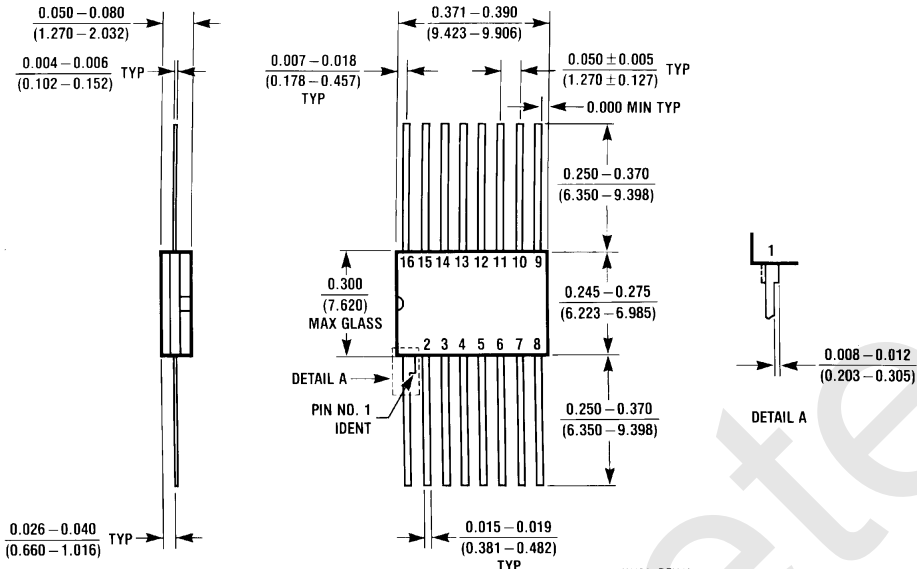

16-Lead Ceramic Flatpak (F)
NS Package Number W16A

W16A (REV. H)

LIFE SUPPORT POLICY

NATIONAL'S PRODUCTS ARE NOT AUTHORIZED FOR USE AS CRITICAL COMPONENTS IN LIFE SUPPORT DEVICES OR SYSTEMS WITHOUT THE EXPRESS WRITTEN APPROVAL OF THE PRESIDENT OF NATIONAL SEMICONDUCTOR CORPORATION. As used herein:

1. Life support devices or systems are devices or systems which, (a) are intended for surgical implant into the body, or (b) support or sustain life, and whose failure to perform, when properly used in accordance with instructions for use provided in the labeling, can be reasonably expected to result in a significant injury to the user.
2. A critical component is any component of a life support device or system whose failure to perform can be reasonably expected to cause the failure of the life support device or system, or to affect its safety or effectiveness.



National Semiconductor Corporation
1111 West Bardin Road
Arlington, TX 76017
Tel: 1(800) 272-9959
Fax: 1(800) 737-7018

National Semiconductor Europe
Fax: (+49) 0-180-530 85 86
Email: cnjwge@tevm2.nsc.com
Deutsch Tel: (+49) 0-180-530 85 85
English Tel: (+49) 0-180-532 78 32
Français Tel: (+49) 0-180-532 93 58
Italiano Tel: (+49) 0-180-534 16 80

National Semiconductor Hong Kong Ltd.
19th Floor, Straight Block,
Ocean Centre, 5 Canton Rd.
Tsimshatsui, Kowloon
Hong Kong
Tel: (852) 2737-1600
Fax: (852) 2736-9960

National Semiconductor Japan Ltd.
Tel: 81-043-299-2309
Fax: 81-043-299-2408

National does not assume any responsibility for use of any circuitry described, no circuit patent licenses are implied and National reserves the right at any time without notice to change said circuitry and specifications.

IMPORTANT NOTICE

Texas Instruments Incorporated and its subsidiaries (TI) reserve the right to make corrections, modifications, enhancements, improvements, and other changes to its products and services at any time and to discontinue any product or service without notice. Customers should obtain the latest relevant information before placing orders and should verify that such information is current and complete. All products are sold subject to TI's terms and conditions of sale supplied at the time of order acknowledgment.

TI warrants performance of its hardware products to the specifications applicable at the time of sale in accordance with TI's standard warranty. Testing and other quality control techniques are used to the extent TI deems necessary to support this warranty. Except where mandated by government requirements, testing of all parameters of each product is not necessarily performed.

TI assumes no liability for applications assistance or customer product design. Customers are responsible for their products and applications using TI components. To minimize the risks associated with customer products and applications, customers should provide adequate design and operating safeguards.

TI does not warrant or represent that any license, either express or implied, is granted under any TI patent right, copyright, mask work right, or other TI intellectual property right relating to any combination, machine, or process in which TI products or services are used. Information published by TI regarding third-party products or services does not constitute a license from TI to use such products or services or a warranty or endorsement thereof. Use of such information may require a license from a third party under the patents or other intellectual property of the third party, or a license from TI under the patents or other intellectual property of TI.

Reproduction of TI information in TI data books or data sheets is permissible only if reproduction is without alteration and is accompanied by all associated warranties, conditions, limitations, and notices. Reproduction of this information with alteration is an unfair and deceptive business practice. TI is not responsible or liable for such altered documentation. Information of third parties may be subject to additional restrictions.

Resale of TI products or services with statements different from or beyond the parameters stated by TI for that product or service voids all express and any implied warranties for the associated TI product or service and is an unfair and deceptive business practice. TI is not responsible or liable for any such statements.

TI products are not authorized for use in safety-critical applications (such as life support) where a failure of the TI product would reasonably be expected to cause severe personal injury or death, unless officers of the parties have executed an agreement specifically governing such use. Buyers represent that they have all necessary expertise in the safety and regulatory ramifications of their applications, and acknowledge and agree that they are solely responsible for all legal, regulatory and safety-related requirements concerning their products and any use of TI products in such safety-critical applications, notwithstanding any applications-related information or support that may be provided by TI. Further, Buyers must fully indemnify TI and its representatives against any damages arising out of the use of TI products in such safety-critical applications.

TI products are neither designed nor intended for use in military/aerospace applications or environments unless the TI products are specifically designated by TI as military-grade or "enhanced plastic." Only products designated by TI as military-grade meet military specifications. Buyers acknowledge and agree that any such use of TI products which TI has not designated as military-grade is solely at the Buyer's risk, and that they are solely responsible for compliance with all legal and regulatory requirements in connection with such use.

TI products are neither designed nor intended for use in automotive applications or environments unless the specific TI products are designated by TI as compliant with ISO/TS 16949 requirements. Buyers acknowledge and agree that, if they use any non-designated products in automotive applications, TI will not be responsible for any failure to meet such requirements.

Following are URLs where you can obtain information on other Texas Instruments products and application solutions:

Products

Audio	www.ti.com/audio
Amplifiers	amplifier.ti.com
Data Converters	dataconverter.ti.com
DLP® Products	www.dlp.com
DSP	dsp.ti.com
Clocks and Timers	www.ti.com/clocks
Interface	interface.ti.com
Logic	logic.ti.com
Power Mgmt	power.ti.com
Microcontrollers	microcontroller.ti.com
RFID	www.ti-rfid.com
OMAP Mobile Processors	www.ti.com/omap
Wireless Connectivity	www.ti.com/wirelessconnectivity

Applications

Communications and Telecom	www.ti.com/communications
Computers and Peripherals	www.ti.com/computers
Consumer Electronics	www.ti.com/consumer-apps
Energy and Lighting	www.ti.com/energy
Industrial	www.ti.com/industrial
Medical	www.ti.com/medical
Security	www.ti.com/security
Space, Avionics and Defense	www.ti.com/space-avionics-defense
Transportation and Automotive	www.ti.com/automotive
Video and Imaging	www.ti.com/video

TI E2E Community Home Page

e2e.ti.com

Mailing Address: Texas Instruments, Post Office Box 655303, Dallas, Texas 75265
Copyright © 2011, Texas Instruments Incorporated