

QUAD BUS DRIVER | 8T09

DIGITAL 8000 SERIES TTL/MSI

DESCRIPTION

The 8T09 is a high speed quad bus driver device for applications requiring up to 25 loads interconnected on a single bus.

The outputs present a high impedance to the bus when disabled, (control input "1") and active drive when enabled

(control input "0"). This eliminates the resistor pull-up requirement while providing performance superior to open collector schemes. Each output can sink 40mA and drive 300pF loading with guaranteed propagation delay less than 22 nanoseconds.

LOGIC DIAGRAM AND TRUTH TABLE

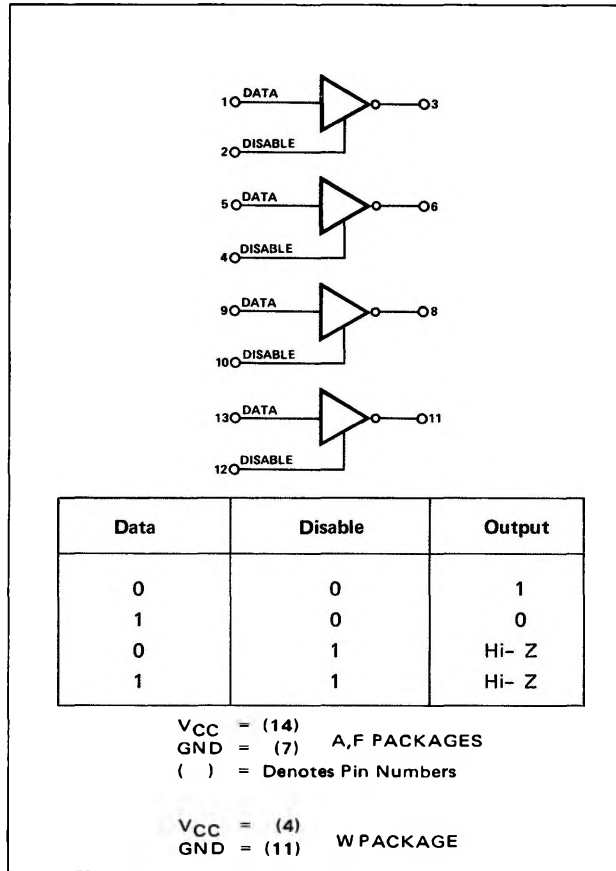

SCHEMATIC DIAGRAM

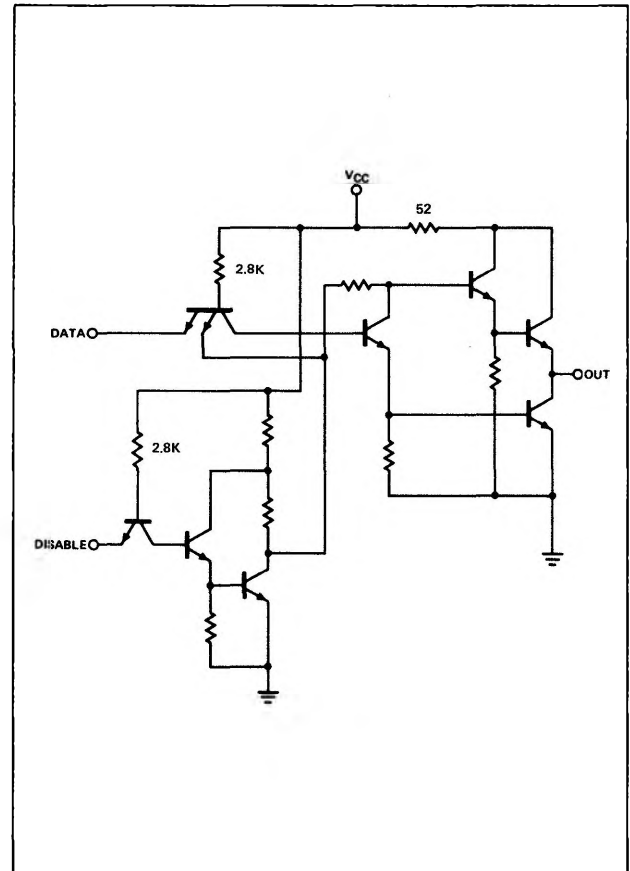

ELECTRICAL CHARACTERISTICS (Over Recommended Operating Temperature And Voltage)

CHARACTERISTICS	LIMITS				TEST CONDITIONS			NOTES
	MIN.	TYP.	MAX.	UNITS	DATA	DISABLE	OUTPUTS	
"1" Output Voltage	2.4	3.0		V	0.8V	0.8V	-5.2mA	7
"0" Output Voltage		0.2	0.4	V	2.0V	0.8V	40mA	8
Output Leakage Current	-40		+40	μA		2.0V	0.4V or 2.4V	3
"1" Input Current			40	μA		4.5V		
"0" Input Current			-2.0	mA	0.4V	0.4V		
Input Latch Voltage	5.5			V	10mA	10mA		
Power/Current Consumption		236/45	340/65	mW/mA				11
Output Short Circuit Current	-40		-120	mA	0V	0V	0V	

SIGNETICS DIGITAL 8000 SERIES TTL/MSI – 8T09

$T_A = 25^\circ\text{C}$ and $V_{CC} = 5.0\text{V}$

CHARACTERISTICS	LIMITS				TEST CONDITIONS			NOTES
	MIN.	TYP.	MAX.	UNITS	DATA	DISABLE	OUTPUTS	
Propagation Delay Data to Output t_{pd+} , t_{pd-}			10 20	ns ns			30pF load 300pF load	9 9
Disable to Output High Z to 0, 0 to High Z			14 22	ns ns			30pF load 300pF load	9 9
High Z to 1, 1 to High Z			14 22	ns ns			30pF load 300pF load	9 9

NOTES:

- All voltage measurements are referenced to the ground terminal. Terminals not specifically referenced are left electrically open.
- All measurements are taken with ground pin tied to zero volts.
- Positive current flow is defined as into the terminal referenced.
- Positive NAND Logic definition:
"UP" Level = "1", "DOWN" Level = "0".
- Precautionary measures should be taken to ensure current limiting in accordance with Absolute Maximum Ratings
- should the isolation diodes become forward biased.
- Measurements apply to each output and the associated data input independently.
- Output source current is supplied through a resistor to ground.
- Output sink current is supplied through a resistor to V_{CC} .
- Refer to AC Test Figures.
- Manufacturer reserves the right to make design and process changes and improvements.
- $V_{CC} = 5.25$ volts.

AC TEST FIGURES AND WAVEFORMS

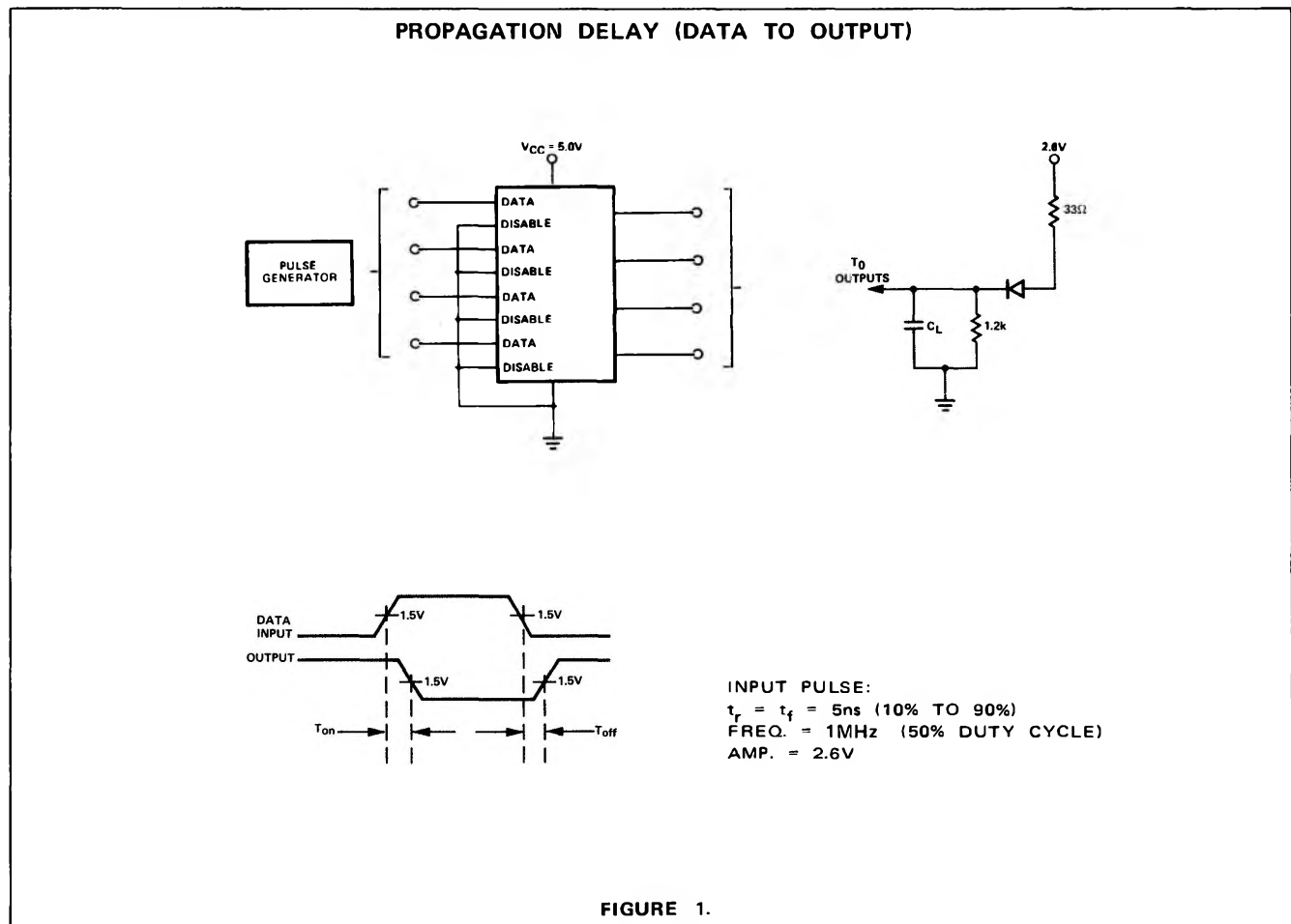

AC TEST FIGURES AND WAVEFORMS (Cont'd)

PROPAGATION DELAY ("0" TO HIGH Z)

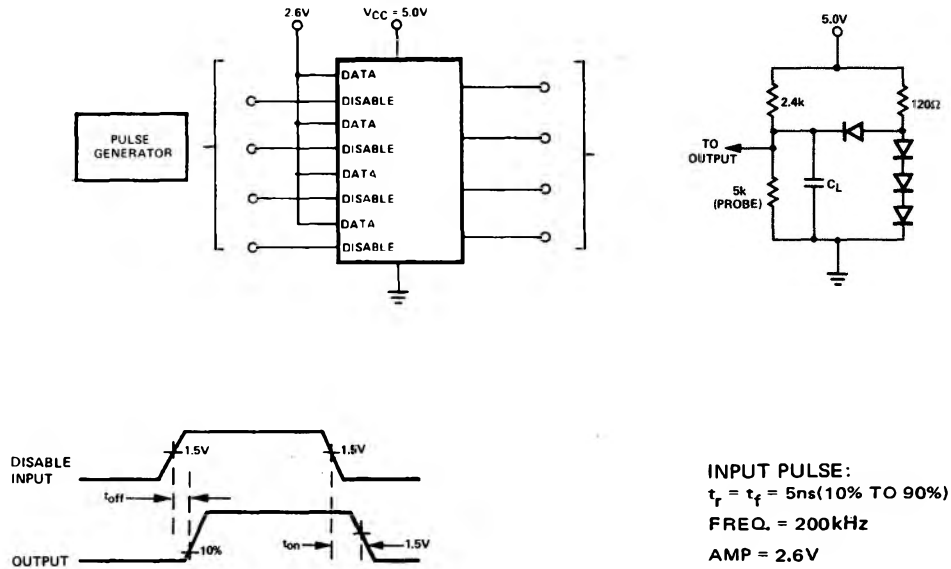

FIGURE 2.

PROPAGATION DELAY ("1" TO HIGH Z)

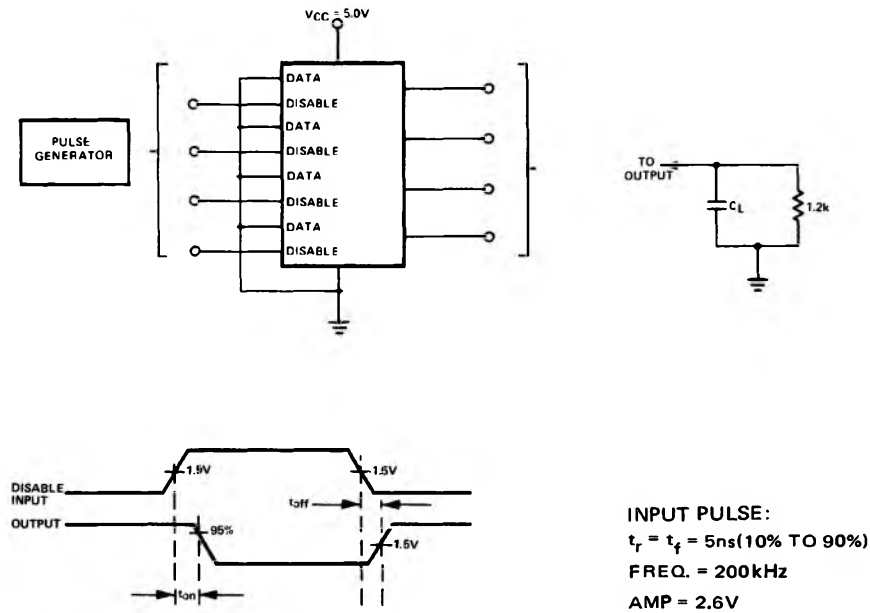
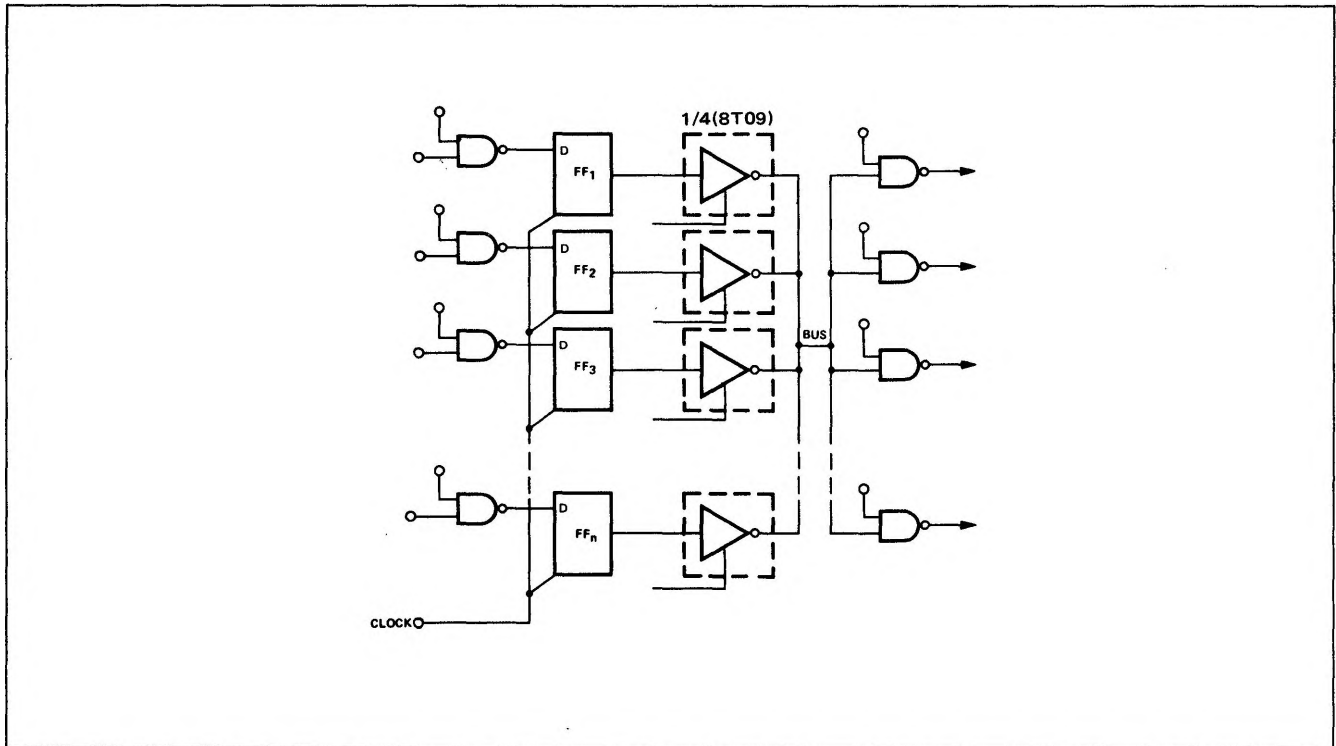

FIGURE 3.

TYPICAL APPLICATION



The above figure illustrates usage of the 8T09 in data processing logic. For example, FF₁ thru FF_n may represent bit X in each of several functions in a minicomputer (accumulators, MQ register, index registers, indirect address

registers, etc.). Transfer from any source to any load, including transfers from one register to another, can take place along the single path labeled "BUS".