

January 1996

Radiation Hardened 4-Bit Synchronous Counter

Features

- Devices QML Qualified in Accordance with MIL-PRF-38535
- Detailed Electrical and Screening Requirements are Contained in SMD# 5962-96716 and Intersil's QM Plan
- 1.25 Micron Radiation Hardened SOS CMOS
- Total Dose >300K RAD (Si)
- Single Event Upset (SEU) Immunity: <math> < 1 \times 10^{-10}</math> Errors/Bit/Day (Typ)
- SEU LET Threshold >100 MEV-cm²/mg
- Dose Rate Upset >10¹¹ RAD (Si)/s, 20ns Pulse
- Dose Rate Survivability >10¹² RAD (Si)/s, 20ns Pulse
- Latch-Up Free Under Any Conditions
- Military Temperature Range -55°C to +125°C
- Significant Power Reduction Compared to ALSTTL Logic
- DC Operating Voltage Range 4.5V to 5.5V
- Input Logic Levels
 - VIL = 0.8V Max
 - VIH = VCC/2 Min
- Input Current ≤ 1μA at VOL, VOH
- Fast Propagation Delay 25ns (Max), 16ns (Typ)

Description

The Intersil ACTS161MS is a Radiation Hardened 4-Bit Binary Synchronous Counter, featuring asynchronous reset and load ahead carry logic. The MR is an active low master reset. SPE is an active low Synchronous Parallel Enable which disables counting and allows data at the preset inputs (P0 - P3) to load the counter. CP is the positive edge clock. TC is the terminal count or carry output. Both TE and PE must be high for counting to occur, but are irrelevant to loading. TE low will keep TC low.

The ACTS161MS utilizes advanced CMOS/SOS technology to achieve high-speed operation. This device is a member of a radiation hardened, high-speed, CMOS/SOS Logic family.

The ACTS161MS is supplied in a 16 lead Ceramic Flatpack (K suffix) or a Ceramic Dual-In-Line Package (D suffix).

Pinouts

16 PIN CERAMIC DUAL-IN-LINE
MIL-STD-1835, DESIGNATOR CDIP2-T16,
LEAD FINISH C
TOP VIEW

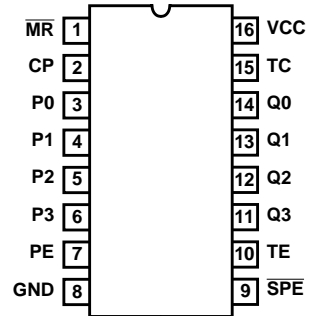

16 PIN CERAMIC FLATPACK
MIL-STD-1835, DESIGNATOR CDFP4-F16,
LEAD FINISH C
TOP VIEW

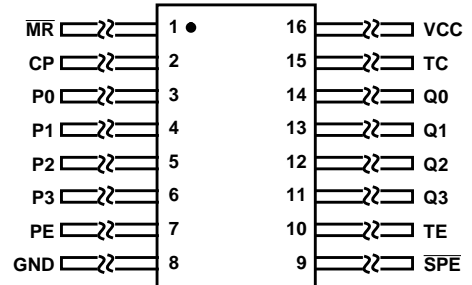

Ordering Information

PART NUMBER	TEMPERATURE RANGE	SCREENING LEVEL	PACKAGE
5962F9671601VEC	-55°C to +125°C	MIL-PRF-38535 Class V	16 Lead SBDIP
5962F9671601VXC	-55°C to +125°C	MIL-PRF-38535 Class V	16 Lead Ceramic Flatpack
ACTS161D/Sample	25°C	Sample	16 Lead SBDIP
ACTS161K/Sample	25°C	Sample	16 Lead Ceramic Flatpack
ACTS161HMSR	25°C	Die	Die

Functional Diagram

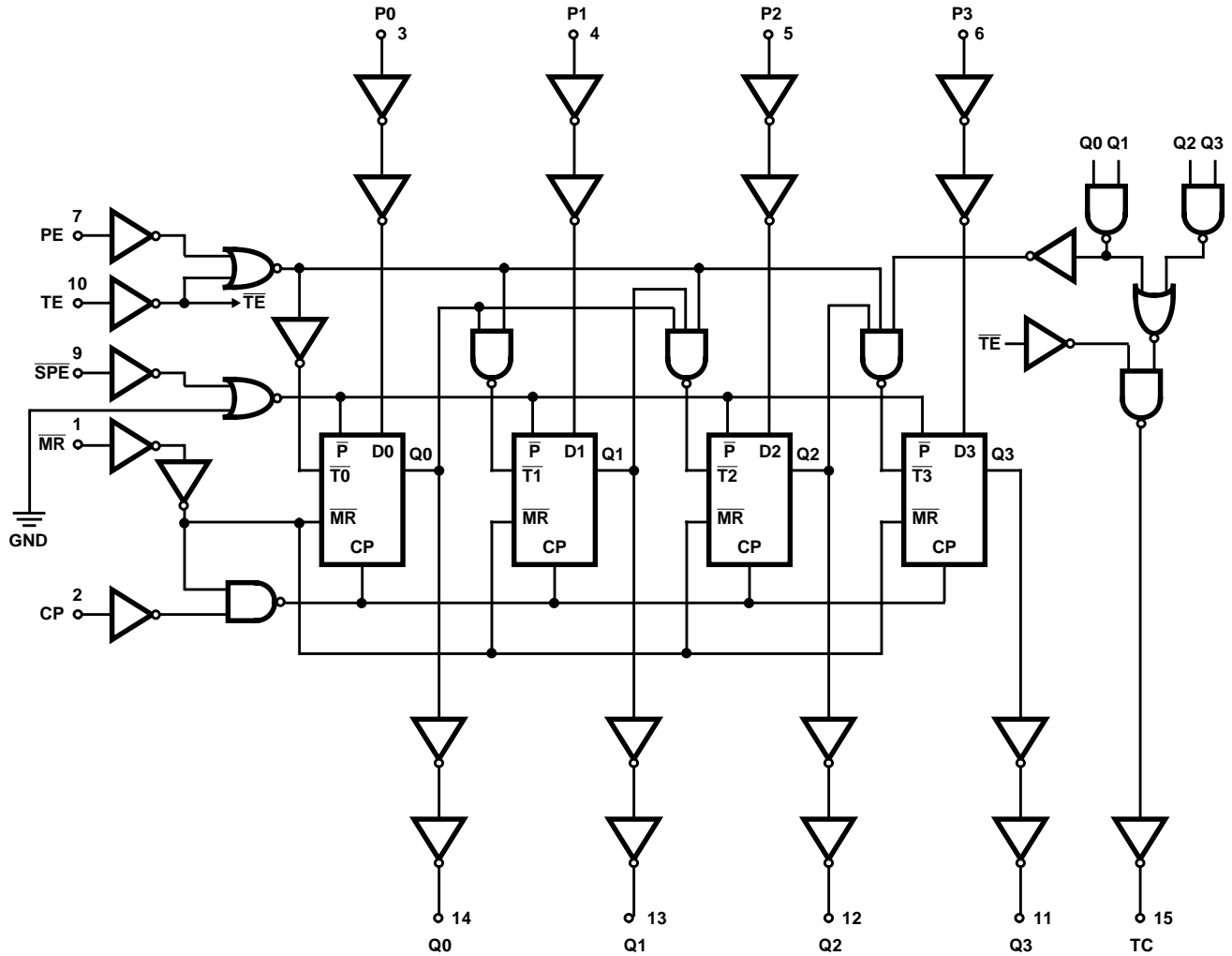

TRUTH TABLE

OPERATING MODE	INPUTS						OUTPUTS	
	MR	CP	PE	TE	SPE	P _N	Q _N	TC
Reset (Clear)	L	X	X	X	X	X	L	L
Parallel Load	H		X	X	l	l	L	L
	H		X	X	l	h	H	(Note 1)
Count	H		h	h	h (Note 3)	X	count	(Note 1)
Inhibit	H	X	l (Note 2)	X	h (Note 3)	X	q _N	(Note 1)
	H	X	X	l (Note 2)	h (Note 3)	X	q _N	L

H = High Steady State, L = Low Steady State, h = High voltage level one setup time prior to the Low-to-High clock transition, l = Low voltage level one setup time prior to the Low-to-High clock transition, X = Don't Care, q = Lower case letters indicate the state of the referenced output prior to the Low-to-High clock transition, = Low-to-High Transition.

NOTES:

1. The TC output is High when TE is High and the counter is at Terminal Count (HHHH).
2. The High-to-Low transition of PE or TE should only occur while CP is High for conventional operation.
3. The Low-to-High transition of SPE should only occur while CP is High for conventional operation.

ACTS161MS

Die Characteristics

DIE DIMENSIONS:

88 mils x 88 mils
2240mm x 2240mm

METALLIZATION:

Type: AlSi
Metal 1 Thickness: $7.125\text{k}\text{\AA} \pm 1.125\text{k}\text{\AA}$
Metal 2 Thickness: $9\text{k}\text{\AA} \pm 1\text{k}\text{\AA}$

GLASSIVATION:

Type: SiO_2
Thickness: $8\text{k}\text{\AA} \pm 1\text{k}\text{\AA}$

WORST CASE CURRENT DENSITY:

$< 2.0 \times 10^5 \text{A/cm}^2$

BOND PAD SIZE:

$110\mu\text{m} \times 110\mu\text{m}$
4.3 mils x 4.3 mils

Metallization Mask Layout

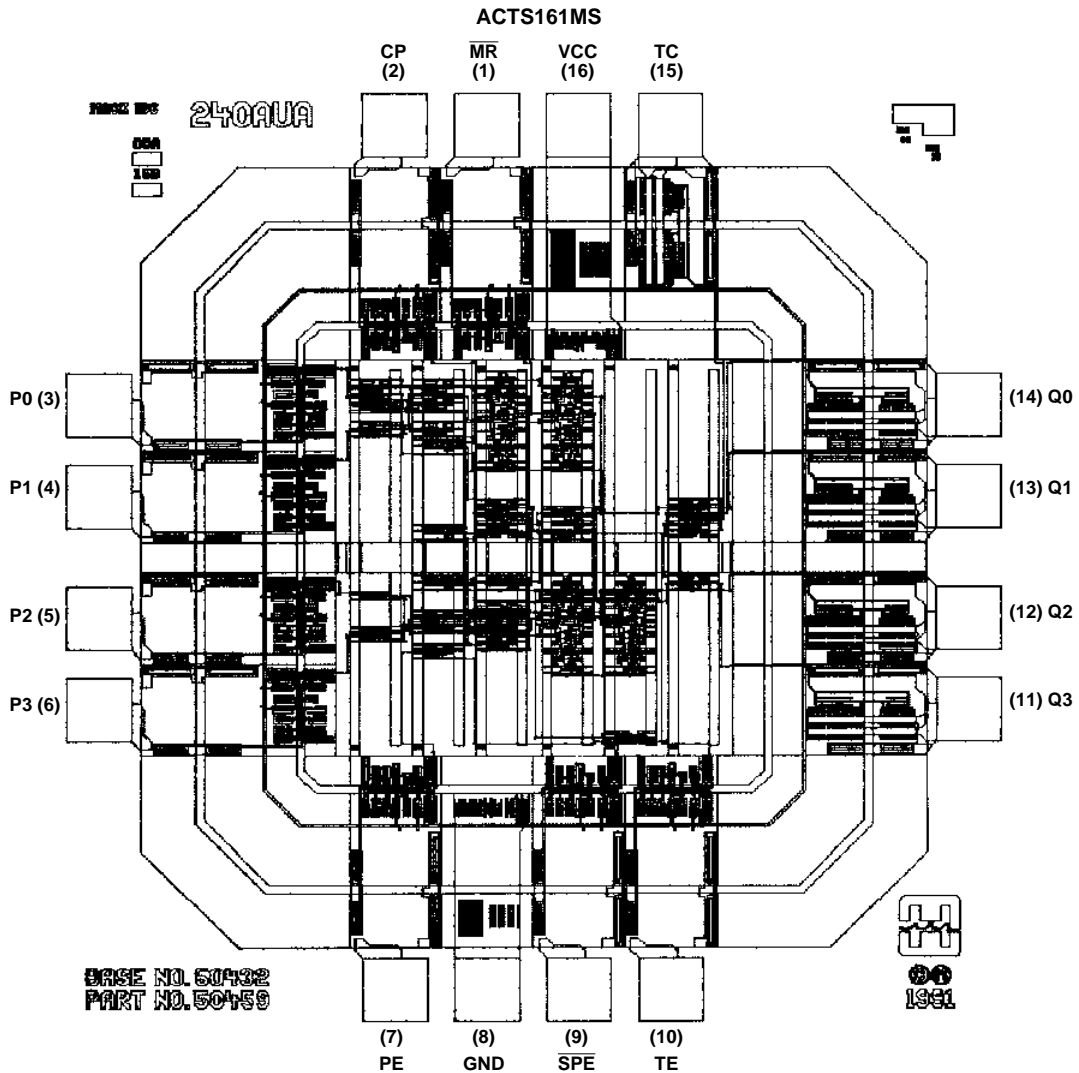

All Intersil semiconductor products are manufactured, assembled and tested under **ISO9000** quality systems certification.

Intersil products are sold by description only. Intersil Corporation reserves the right to make changes in circuit design and/or specifications at any time without notice. Accordingly, the reader is cautioned to verify that data sheets are current before placing orders. Information furnished by Intersil is believed to be accurate and reliable. However, no responsibility is assumed by Intersil or its subsidiaries for its use; nor for any infringements of patents or other rights of third parties which may result from its use. No license is granted by implication or otherwise under any patent or patent rights of Intersil or its subsidiaries.

For information regarding Intersil Corporation and its products, see web site <http://www.intersil.com>

Sales Office Headquarters

NORTH AMERICA

Intersil Corporation
P. O. Box 883, Mail Stop 53-204
Melbourne, FL 32902
TEL: (321) 724-7000
FAX: (321) 724-7240

EUROPE

Intersil SA
Mercure Center
100, Rue de la Fusee
1130 Brussels, Belgium
TEL: (32) 2.724.2111
FAX: (32) 2.724.22.05

ASIA

Intersil (Taiwan) Ltd.
Taiwan Limited
7F-6, No. 101 Fu Hsing North Road
Taipei, Taiwan
Republic of China
TEL: (886) 2 2716 9310
FAX: (886) 2 2715 3029