



# Pseudo Differential, 555kSPS, 12-Bit ADC in 8-lead SOT-23

## Preliminary Technical Data

## AD7453

### FEATURES

Specified for  $V_{DD}$  of 2.7 V to 5.25 V  
 Low Power at max Throughput Rate:  
 3.75 mW typ at 555kSPS with  $V_{DD} = 3$  V  
 9 mW typ at 555kSPS with  $V_{DD} = 5$  V  
 Pseudo Differential Analog Input  
 Wide Input Bandwidth:  
 70dB SINAD at 100kHz Input Frequency  
 Flexible Power/Serial Clock Speed Management  
 No Pipeline Delays  
 High Speed Serial Interface - SPI™/QSPI™/  
 MICROWIRE™/ DSP Compatible  
 Power-Down Mode: 1 $\mu$ A max  
 8 Pin SOT-23 and MSOP Packages

### APPLICATIONS

Transducer Interface  
 Battery Powered Systems  
 Data Acquisition Systems  
 Portable Instrumentation  
 Motor Control  
 Communications

### GENERAL DESCRIPTION

The AD7453 is a 12-bit, low power, successive-approximation (SAR) analog-to-digital converter that features a pseudo differential analog input. This part operates from a single 2.7 V to 5.25 V power supply and features throughput rates up to 555kSPS.

The part contains a low-noise, wide bandwidth, differential track and hold amplifier (T/H) which can handle input frequencies in excess of 1MHz with the -3dB point being 20MHz typically. The reference voltage for the AD7453 is applied externally to the  $V_{REF}$  pin and can be varied from 100mV to 3.5 V.

The conversion process and data acquisition are controlled using  $\overline{CS}$  and the serial clock allowing the device to interface with Microprocessors or DSPs. The input signals are sampled on the falling edge of  $\overline{CS}$  and the conversion is also initiated at this point.

The SAR architecture of this part ensures that there are no pipeline delays.

MICROWIRE is a trademark of National Semiconductor Corporation.  
 SPI and QSPI are trademarks of Motorola, Inc.

REV. PrD 5 March 03

Information furnished by Analog Devices is believed to be accurate and reliable. However, no responsibility is assumed by Analog Devices for its use, nor for any infringements of patents or other rights of third parties which may result from its use. No license is granted by implication or otherwise under any patent or patent rights of Analog Devices.

### FUNCTIONAL BLOCK DIAGRAM

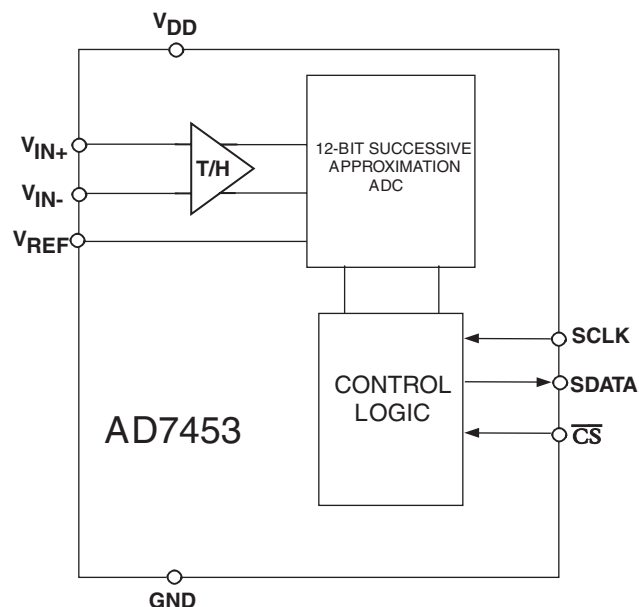

The AD7453 use advanced design techniques to achieve very low power dissipation at high throughput rates.

### PRODUCT HIGHLIGHTS

1. Operation with 2.7 V to 5.25 V power supplies.
2. Low Power Consumption.

With a 3V supply, the AD7453 offers 3.75mW typ power consumption for 555kSPS throughput.

3. Pseudo Differential Analog Input.
4. Variable Voltage Reference Input
5. Flexible Power/Serial Clock Speed Management.

The conversion rate is determined by the serial clock, allowing the power to be reduced as the conversion time is reduced through the serial clock speed increase. This part also features a shutdown mode to maximize power efficiency at lower throughput rates.

6. No Pipeline Delay.
7. Accurate control of the sampling instant via a  $\overline{CS}$  input and once off conversion control.
8. ENOB > 8 bits typically with 100mV reference.

PRELIMINARY TECHNICAL DATA

# AD7453 - SPECIFICATIONS<sup>1</sup>

( $V_{DD} = 2.7V$  to  $5.25V$ ,  $f_{SCLK} = 10MHz$ ,  $f_S = 555kSPS$ ,  $V_{REF} = 2.5V$ ;  $F_{IN} = 100kHz$ ;  
 $T_A = T_{MIN}$  to  $T_{MAX}$ , unless otherwise noted.)

Parameter	Test Conditions/Comments	B Version <sup>1</sup>	Unit
<b>DYNAMIC PERFORMANCE</b>			
Signal to (Noise + Distortion) (SINAD) <sup>2</sup>		70	dB min
Total Harmonic Distortion (THD) <sup>2</sup>	-80dB typ	-75	dB max
Peak Harmonic or Spurious Noise <sup>2</sup>	-82dB typ	-75	dB max
Intermodulation Distortion (IMD) <sup>2</sup>			
Second Order Terms		-85	dB typ
Third Order Terms		-85	dB typ
Aperture Delay <sup>2</sup>		10	ns typ
Aperture Jitter <sup>2</sup>		50	ps typ
Full Power Bandwidth <sup>2</sup>	@ -3 dB	20	MHz typ
	@ -0.1 dB	2.5	MHz typ
<b>DC ACCURACY</b>			
Resolution		12	Bits
Integral Nonlinearity (INL) <sup>2</sup>		±1	LSB max
Differential Nonlinearity (DNL) <sup>2</sup>	Guaranteed No Missed Codes to 12 Bits.		
Offset Error <sup>2</sup>		±1	LSB max
Gain Error <sup>2</sup>		±3	LSB max
		±3	LSB max
<b>ANALOG INPUT</b>			
Full Scale Input Span	$V_{IN+} - V_{IN-}$	$V_{REF}$	V
Absolute Input Voltage			
$V_{IN+}$		$V_{REF}$	V
$V_{IN-}$ <sup>3</sup>		±100	mV
DC Leakage Current		±1	µA max
Input Capacitance	When in Track	20	pF typ
	When in Hold	6	pF typ
<b>REFERENCE INPUT</b>			
$V_{REF}$ Input Voltage	±1% tolerance for specified performance	2.5 <sup>4</sup>	V
DC Leakage Current		±1	µA max
$V_{REF}$ Input Capacitance		15	pF typ
<b>LOGIC INPUTS</b>			
Input High Voltage, $V_{INH}$		2.4	V min
Input Low Voltage, $V_{INL}$		0.8	V max
Input Current, $I_{IN}$	Typically 10nA, $V_{IN} = 0V$ or $V_{DD}$	±1	µA max
Input Capacitance, $C_{IN}$ <sup>5</sup>		10	pF max
<b>LOGIC OUTPUTS</b>			
Output High Voltage, $V_{OH}$	$V_{DD} = 4.75V$ to $5.25V$ $I_{SOURCE} = 200\mu A$ $V_{DD} = 2.7V$ to $3.6V$	2.8	V min
Output Low Voltage, $V_{OL}$	$I_{SOURCE} = 200\mu A$ $I_{SINK} = 200\mu A$	2.4	V min
Floating-State Leakage Current		0.4	V max
Floating-State Output Capacitance <sup>5</sup>		±1	µA max
Output Coding		10	pF max
		Straight (Natural)	
		Binary	
<b>CONVERSION RATE</b>			
Conversion Time	1.6µs with a 10MHz SCLK	16	SCLK cycles
Track/Hold Acquisition Time <sup>2</sup>	Sine Wave Input	200	ns max
	Step Input	TBD	ns max
Throughput Rate <sup>6</sup>		555	kSPS max

**AD7453 - SPECIFICATIONS<sup>1</sup>**

Parameter	Test Conditions/Comments	B Version <sup>1</sup>	Units
<b>POWER REQUIREMENTS</b>			
$V_{DD}$		2.7/5.25	Vmin/max
$I_{DD}$ <sup>6,7</sup>			
Normal Mode(Static)	SCLK On or Off	0.5	mA typ
Normal Mode (Operational)	$V_{DD} = 4.75 \text{ V to } 5.25 \text{ V}$	1.8	mA max
	$V_{DD} = 2.7 \text{ V to } 3.6 \text{ V}$	1.25	mA max
Full Power-Down Mode	SCLK On or Off	1	$\mu\text{A}$ max
Power Dissipation			
Normal Mode (Operational)	$V_{DD} = 5 \text{ V.}$	9	mW max
	$V_{DD} = 3 \text{ V.}$	3.75	mW max
Full Power-Down	$V_{DD} = 5 \text{ V. SCLK On or Off}$	5	$\mu\text{W}$ max
	$V_{DD} = 3 \text{ V. SCLK On or Off}$	3	$\mu\text{W}$ max

## NOTES

<sup>1</sup>Temperature ranges as follows: B Versions:  $-40^{\circ}\text{C}$  to  $+85^{\circ}\text{C}$ .<sup>2</sup>See 'Terminology' section.<sup>3</sup>A small DC input is applied to  $V_{IN-}$  to provide a pseudo ground for  $V_{IN+}$ .<sup>4</sup>The AD7453 is functional with a reference input in the range 100mV to 3.5 V.<sup>5</sup>Sample tested @  $+25^{\circ}\text{C}$  to ensure compliance.<sup>6</sup>See POWER VERSUS THROUGHPUT RATE section.<sup>7</sup>Measured with a midscale DC input.

Specifications subject to change without notice.

# TIMING SPECIFICATIONS<sup>1,2</sup>

( $V_{DD} = 2.7V$  to  $5.25V$ ,  $f_{SCLK} = 10MHz$ ,  $f_S = 555kSPS$ ,  $V_{REF} = 2.5 V$ ;  $F_{IN} = 100kHz$ ;  
 $T_A = T_{MIN}$  to  $T_{MAX}$ , unless otherwise noted.)

Parameter	Limit at $T_{MIN}$ , $T_{MAX}$	Units	Description
$f_{SCLK}$ <sup>3</sup>	10 10	kHz min MHz max	
$t_{CONVERT}$	$16 \times t_{SCLK}$		$t_{SCLK} = 1/f_{SCLK}$
$t_{QUIET}$	1.6 25	$\mu s$ max ns min	Minimum Quiet Time between the End of a Serial Read and the Next Falling Edge of $\overline{CS}$
$t_1$	10	ns min	Minimum $\overline{CS}$ Pulsewidth
$t_2$	10	ns min	$\overline{CS}$ falling Edge to SCLK Falling Edge Setup Time
$t_3$ <sup>4</sup>	20	ns max	Delay from $\overline{CS}$ Falling Edge Until SDATA 3-State Disabled
$t_4$ <sup>4</sup>	40	ns max	Data Access Time After SCLK Falling Edge
$t_5$	$0.4 t_{SCLK}$	ns min	SCLK High Pulse Width
$t_6$	$0.4 t_{SCLK}$	ns min	SCLK Low Pulse Width
$t_7$	10	ns min	SCLK Edge to Data Valid Hold Time
$t_8$ <sup>5</sup>	10 35	ns min ns max	SCLK Falling Edge to SDATA 3-State Enabled SCLK Falling Edge to SDATA 3-State Enabled
$t_{POWER-UP}$ <sup>6</sup>	1	$\mu s$ max	Power-Up Time from Full Power-Down

NOTES

<sup>1</sup>Sample tested at +25°C to ensure compliance. All input signals are specified with  $t_r = t_f = 5$  ns (10% to 90% of  $V_{DD}$ ) and timed from a voltage level of 1.6 Volts.

<sup>2</sup>See Figure 1 and the ‘Serial Interface’ section.

<sup>3</sup>Mark/Space ratio for the SCLK input is 40/60 to 60/40.

<sup>4</sup>Measured with the load circuit of Figure 2 and defined as the time required for the output to cross 0.8 V or 2.4 V with  $V_{DD} = 5$  V and time for an output to cross 0.4 V or 2.0 V for  $V_{DD} = 3$  V.

<sup>5</sup> $t_8$  is derived from the measured time taken by the data outputs to change 0.5 V when loaded with the circuit of Figure 2. The measured number is then extrapolated back to remove the effects of charging or discharging the 50 pF capacitor. This means that the time,  $t_8$ , quoted in the timing characteristics is the true bus relinquish time of the part and is independent of the bus loading.

<sup>6</sup>See ‘Power-up Time’ Section.

Specifications subject to change without notice.

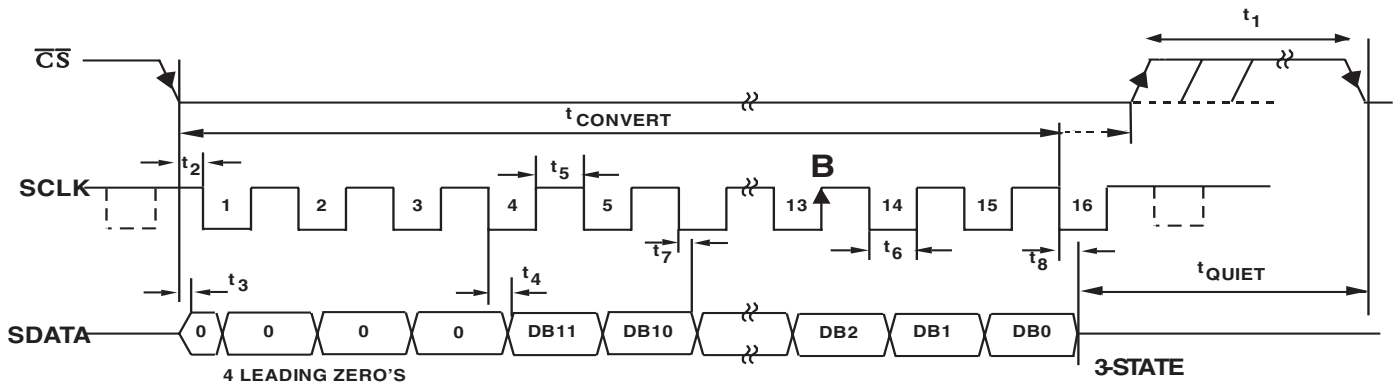

Figure 1. Serial Interface Timing Diagram

**ABSOLUTE MAXIMUM RATINGS<sup>1</sup>**

(T<sub>A</sub> = +25°C unless otherwise noted)

V <sub>DD</sub> to GND	-0.3 V to +7 V
V <sub>IN+</sub> to GND	-0.3 V to V <sub>DD</sub> + 0.3 V
V <sub>IN-</sub> to GND	-0.3 V to V <sub>DD</sub> + 0.3 V
Digital Input Voltage to GND	-0.3 V to +7 V
Digital Output Voltage to GND	-0.3 V to V <sub>DD</sub> + 0.3 V
V <sub>REF</sub> to GND	-0.3 V to V <sub>DD</sub> + 0.3 V
Input Current to Any Pin Except Supplies <sup>2</sup>	.... ±10mA
<b>Operating Temperature Range</b>	
Commercial (A, B Version)	-40°C to +85°C
Storage Temperature Range	-65°C to +150°C
Junction Temperature	+150°C
θ <sub>JA</sub> Thermal Impedance	205.9°C/W (MSOP) 211.5°C/W (SOT-23)
θ <sub>JC</sub> Thermal Impedance	43.74°C/W (MSOP) 91.99°C/W (SOT-23)

**Lead Temperature, Soldering**

Vapor Phase (60 secs)	+215°C
Infrared (15 secs)	+220°C
ESD	1kV

**NOTES**

<sup>1</sup>Stresses above those listed under “Absolute Maximum Ratings” may cause permanent damage to the device. This is a stress rating only and functional operation of the device at these or any other conditions above those listed in the operational sections of this specification is not implied. Exposure to absolute maximum rating conditions for extended periods may affect device reliability.

<sup>2</sup>Transient currents of up to 100 mA will not cause SCR latch up.

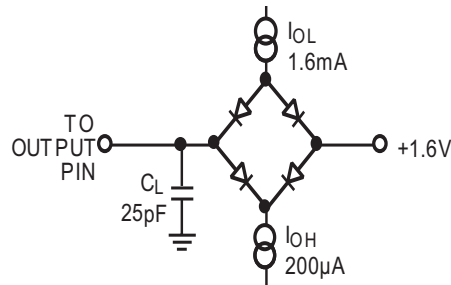

Figure 2. Load Circuit for Digital Output Timing Specifications

**ORDERING GUIDE**

Model	Range	Linearity Error (LSB) <sup>1</sup>	Package Option <sup>4</sup>	Branding Information
AD7453BRT	-40°C to +85°C	±1 LSB	RT-8	C09
AD7453BRM	-40°C to +85°C	±1 LSB	RM-8	C09
TBD <sup>2</sup>	Evaluation Board			
EVAL-CONTROL BRD <sup>2,3</sup>	Controller Board			

**NOTES**

<sup>1</sup>Linearity error here refers to Integral Non-linearity Error.

<sup>2</sup>This can be used as a stand-alone evaluation board or in conjunction with the EVALUATION BOARD CONTROLLER for evaluation/demonstration purposes.

<sup>3</sup>EVALUATION BOARD CONTROLLER. This board is a complete unit allowing a PC to control and communicate with all Analog Devices evaluation boards ending in the CB designators. To order a complete Evaluation Kit, you will need to order the ADC evaluation board i.e. TBD, the EVAL-CONTROL BRD2 and a 12V AC transformer. See the TBD technote for more information.

<sup>4</sup>RT = SOT-23; RM = MSOP

**CAUTION**

ESD (electrostatic discharge) sensitive device. Electrostatic charges as high as 4000 V readily accumulate on the human body and test equipment and can discharge without detection. Although the AD7453 features proprietary ESD protection circuitry, permanent damage may occur on devices subjected to high-energy electrostatic discharges. Therefore, proper ESD precautions are recommended to avoid performance degradation or loss of functionality.



# AD7453

## PIN FUNCTION DESCRIPTION

Pin Mnemonic	Function
$V_{REF}$	Reference Input for the AD7453. An external reference must be applied to this input. This pin should be decoupled to GND with a capacitor of at least 0.1 $\mu$ F.
$V_{IN+}$	Non-Inverting Input.
$V_{IN-}$	Inverting Input. This pin sets the ground reference point for the $V_{IN+}$ input. Connect to Ground or to a small DC offset to provide a pseudo ground.
GND	Analog Ground. Ground reference point for all circuitry on the AD7453. All analog input signals and any external reference signal should be referred to this GND voltage.
$\overline{CS}$	Chip Select. Active low logic input. This input provides the dual function of initiating a conversion on the AD7453 and framing the serial data transfer.
SDATA	Serial Data. Logic Output. The conversion result from the AD7453 is provided on this output as a serial data stream. The bits are clocked out on the falling edge of the SCLK input. The data stream of the AD7453 consists of four leading zeros followed by the 12 bits of conversion data which are provided MSB first. The output coding is Straight (Natural) Binary.
SCLK	Serial Clock. Logic input. SCLK provides the serial clock for accessing data from the part. This clock input is also used as the clock source for the conversion process.
$V_{DD}$	Power Supply Input. $V_{DD}$ is 2.7 V to 5.25 V. This supply should be decoupled to GND with a 0.1 $\mu$ F Capacitor and a 10 $\mu$ F Tantalum Capacitor.

### PIN CONFIGURATION 8-LEAD SOT-23

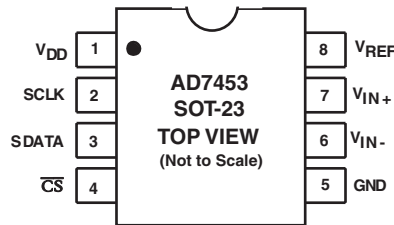

### PIN CONFIGURATION 8-LEAD MSOP

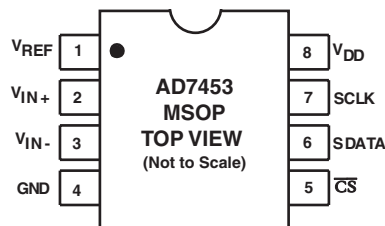

**TERMINOLOGY****Signal to (Noise + Distortion) Ratio**

This is the measured ratio of signal to (noise + distortion) at the output of the ADC. The signal is the rms amplitude of the fundamental. Noise is the sum of all nonfundamental signals up to half the sampling frequency ( $f_s/2$ ), excluding dc. The ratio is dependent on the number of quantization levels in the digitization process; the more levels, the smaller the quantization noise. The theoretical signal to (noise + distortion) ratio for an ideal N-bit converter with a sine wave input is given by:

$$\text{Signal to (Noise + Distortion)} = (6.02N + 1.76) \text{ dB}$$

Thus for a 12-bit converter, this is 74 dB.

**Total Harmonic Distortion**

Total harmonic distortion (THD) is the ratio of the rms sum of harmonics to the fundamental. For the AD7450, it is defined as:

$$\text{THD (dB)} = 20 \log \frac{\sqrt{V_2^2 + V_3^2 + V_4^2 + V_5^2 + V_6^2}}{V_1}$$

where  $V_1$  is the rms amplitude of the fundamental and  $V_2$ ,  $V_3$ ,  $V_4$ ,  $V_5$  and  $V_6$  are the rms amplitudes of the second to the sixth harmonics.

**Peak Harmonic or Spurious Noise**

Peak harmonic or spurious noise is defined as the ratio of the rms value of the next largest component in the ADC output spectrum (up to  $f_s/2$  and excluding dc) to the rms value of the fundamental. Normally, the value of this specification is determined by the largest harmonic in the spectrum, but for ADCs where the harmonics are buried in the noise floor, it will be a noise peak.

**Intermodulation Distortion**

With inputs consisting of sine waves at two frequencies,  $f_a$  and  $f_b$ , any active device with nonlinearities will create distortion products at sum and difference frequencies of  $m f_a \pm n f_b$  where  $m, n = 0, 1, 2, 3$ , etc. Intermodulation distortion terms are those for which neither  $m$  nor  $n$  are equal to zero. For example, the second order terms include  $(f_a + f_b)$  and  $(f_a - f_b)$ , while the third order terms include  $(2f_a + f_b)$ ,  $(2f_a - f_b)$ ,  $(f_a + 2f_b)$  and  $(f_a - 2f_b)$ .

The AD7453 is tested using the CCIF standard where two input frequencies near the top end of the input bandwidth are used. In this case, the second order terms are usually distanced in frequency from the original sine waves while the third order terms are usually at a frequency close to the input frequencies. As a result, the second and third order terms are specified separately. The calculation of the intermodulation distortion is as per the THD specification where it is the ratio of the rms sum of the individual distortion products to the rms amplitude of the sum of the fundamentals expressed in dBs.

**Aperture Delay**

This is the amount of time from the leading edge of the sampling clock until the ADC actually takes the sample.

**Aperture Jitter**

This is the sample to sample variation in the effective point in time at which the actual sample is taken.

**Full Power Bandwidth**

The full power bandwidth of an ADC is that input frequency at which the amplitude of the reconstructed fundamental is reduced by 0.1dB or 3dB for a full scale input.

**Integral Nonlinearity (INL)**

This is the maximum deviation from a straight line passing through the endpoints of the ADC transfer function.

**Differential Nonlinearity (DNL)**

This is the difference between the measured and the ideal 1 LSB change between any two adjacent codes in the ADC.

**Offset Error**

This is the deviation of the first code transition (000...000 to 000...001) from the ideal (i.e. AGND + 1LSB)

**Gain Error**

This is the deviation of the last code transition (111...110 to 111...111) from the ideal (i.e.,  $V_{REF} - 1\text{LSB}$ ), after the Offset Error has been adjusted out.

**Track/Hold Acquisition Time**

The track/hold amplifier returns into track mode on the 13th SCLK rising edge (see the "Serial Interface Section"). The track/hold acquisition time is the minimum time required for the track and hold amplifier to remain in track mode for its output to reach and settle to within 0.5 LSB of the applied input signal.

**Power Supply Rejection Ratio (PSRR)**

The power supply rejection ratio is defined as the ratio of the power in the ADC output at full-scale frequency,  $f$ , to the power of a 120mV p-p sine wave applied to the ADC  $V_{DD}$  supply of frequency  $f_s$ . The frequency of this input varies from 1kHz to 1MHz.

$$\text{PSRR (dB)} = 10 \log (P_f/P_{f_s})$$

$P_f$  is the power at frequency  $f$  in the ADC output;  $P_{f_s}$  is the power at frequency  $f_s$  in the ADC output.

# AD7453

## PERFORMANCE CURVES

(Default Conditions:  $T_A = 25^\circ\text{C}$ ,  $F_s = 555\text{kSPS}$ ,  $F_{\text{SCLK}} = 10\text{MHz}$ ,  $V_{\text{DD}} = 2.7\text{ V to } 5.25\text{ V}$ ,  $V_{\text{REF}} = 2.5\text{ V}$ )

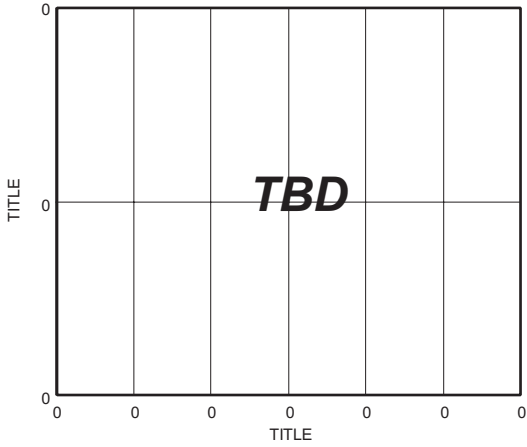

*TPC 1. SINAD vs Analog Input Frequency for Various Supply Voltages*

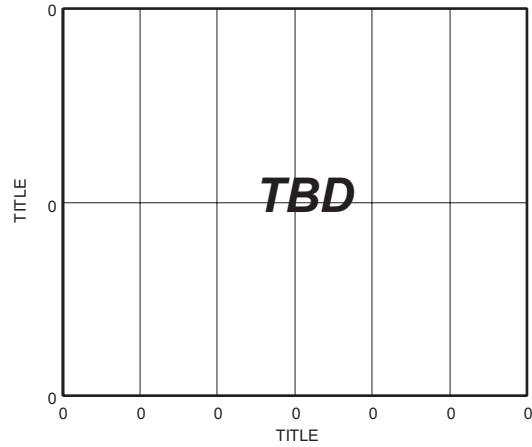

*TPC 3. PSRR vs. Supply Ripple Frequency with Supply Decoupling of TBD*

TPC 2 and TPC 3 shows the Power Supply Rejection Ratio (see Terminology) versus  $V_{\text{DD}}$  supply ripple frequency for the AD7453 with and without power supply decoupling respectively.

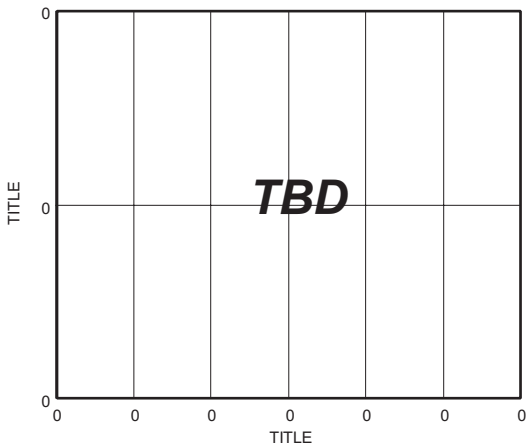

*TPC 2. PSRR vs. Supply Ripple Frequency without Supply Decoupling*

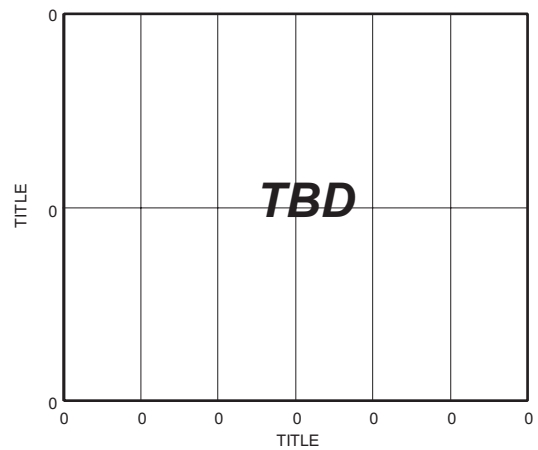

*TPC 4. Dynamic Performance*

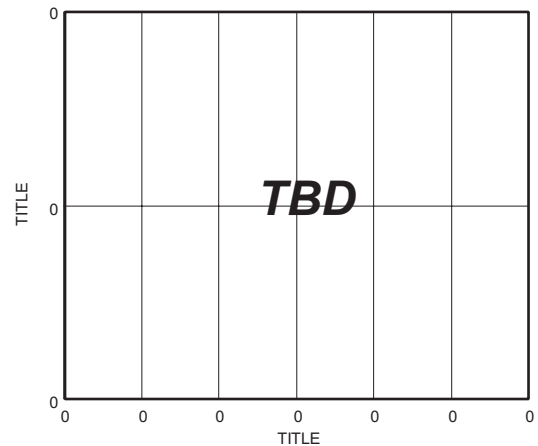

*TPC 5. Typical DNL*



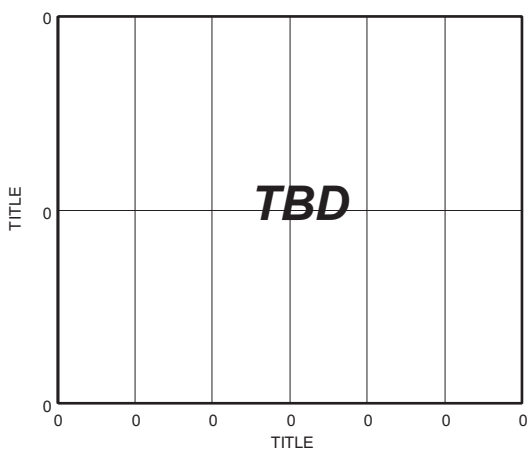

TPC 6. Typical INL

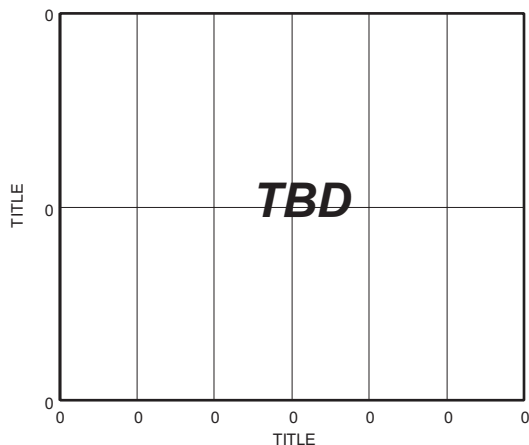

TPC 7. Histogram of 10000 conversions of a DC Input

**CIRCUIT INFORMATION**

The AD7453 is a 12-bit, fast, low power, single supply, successive approximation analog-to-digital converter (ADC) with a pseudo differential analog input. It operates with a single 2.7 V to 5.25 V power supply and is capable of throughput rates up to 555kSPS when supplied with an 10MHz SCLK. It requires an external reference to be applied to the  $V_{REF}$  pin.

The AD7453 has an on-chip differential track and hold amplifier, a successive approximation (SAR) ADC and a serial interface, housed in either an 8-lead SOT-23 or MSOP package. The serial clock input accesses data from the part and also provides the clock source for the successive-approximation ADC. The AD7453 features a power-down option for reduced power consumption between conversions. The power-down feature is implemented across the standard serial interface as described in the ‘Modes of Operation’ section.

**CONVERTER OPERATION**

The AD7453 is a successive approximation ADC based around two capacitive DACs. Figures 3 and 4 show simplified schematics of the ADC in Acquisition and Conversion phase respectively. The ADC comprises of Control Logic, a SAR and two capacitive DACs. In figure 3 (acquisition phase), SW3 is closed and SW1 and SW2 are in position A, the comparator is held in a balanced condition and the sampling capacitor arrays acquire the differential signal on the input.

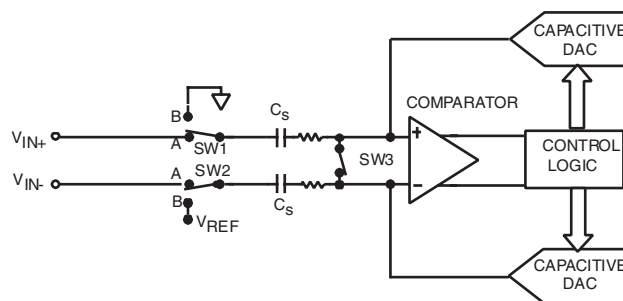

Figure 3. ADC Acquisition Phase

When the ADC starts a conversion (figure 4), SW3 will open and SW1 and SW2 will move to position B, causing the comparator to become unbalanced. Both inputs are disconnected once the conversion begins. The Control Logic and the charge redistribution DACs are used to add and subtract fixed amounts of charge from the sampling capacitor arrays to bring the comparator back into a balanced condition. When the comparator is rebalanced, the conversion is complete. The Control Logic generates the ADC’s output code. The output impedances of the sources driving the  $V_{IN+}$  and the  $V_{IN-}$  pins must be matched otherwise the two inputs will have different settling times, resulting in errors.

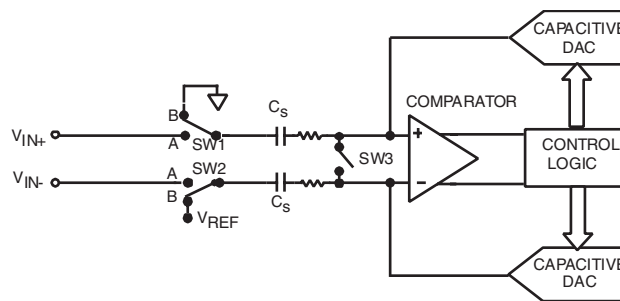

Figure 4. ADC Conversion Phase

**ADC TRANSFER FUNCTION**

The output coding for the AD7453 is straight (natural) binary. The designed code transitions occur at successive LSB values (i.e. 1LSB, 2LSBs, etc.). The LSB size is  $V_{REF}/4096$  and the ideal transfer characteristic is shown in figure 5.

# AD7453

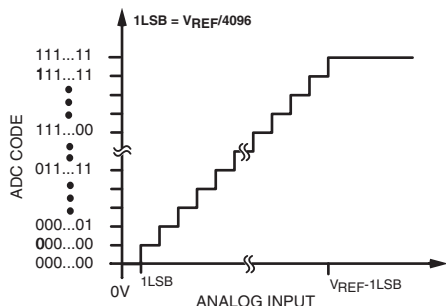

Figure 5. Ideal Transfer Characteristic

## TYPICAL CONNECTION DIAGRAM

Figure 6 shows a typical connection diagram for the AD7453. In this setup the GND pin is connected to the analog ground plane of the system. The  $V_{REF}$  pin is connected to the AD780, 2.5 V decoupled reference source to setup the analog input range of 2.5 V. The signal source is connected to the  $V_{IN+}$  analog input via a unity gain buffer. A DC voltage in the range  $-100\text{mV}$  to  $+100\text{mV}$  is connected to the  $V_{IN-}$  pin to provide a pseudo ground for the  $V_{IN+}$  input. The  $V_{DD}$  pin should be decoupled to AGND with a  $1\mu\text{F}$  tantalum capacitor in parallel with a  $0.1\mu\text{F}$  ceramic capacitor. The reference pin should be decoupled to AGND with a capacitor of at least  $0.1\mu\text{F}$ . The conversion result is output in a 16-bit word with four leading zeros followed by the MSB of the 12-bit result.

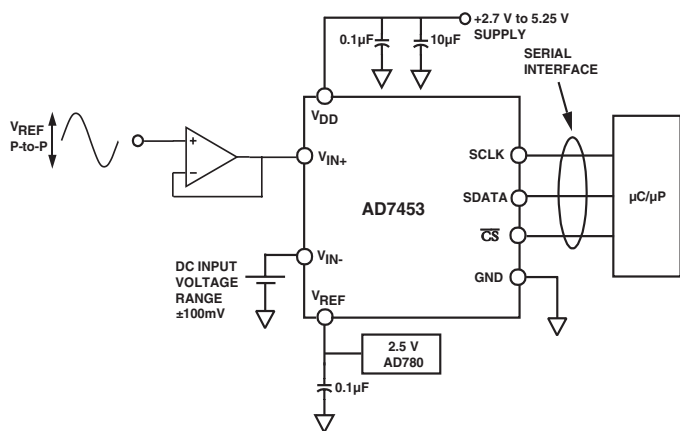

Figure 6. Typical Connection Diagram

## THE ANALOG INPUT

The AD7453 has a pseudo differential analog input. The  $V_{IN+}$  input is coupled to the signal source and must have an amplitude of  $V_{REF}$  peak-peak to make use of the full dynamic range of the part. A DC input in the range  $-100\text{mV}$  to  $+100\text{mV}$  is applied to the  $V_{IN-}$ . The voltage applied to this input provides an offset from ground or a pseudo ground for the  $V_{IN+}$  input. The main benefit of pseudo differential inputs is that they separate the analog input signal ground from the ADC's ground, allowing DC common-mode voltages to be cancelled.

Because the ADC operates from a single supply, it will be necessary to level shift ground based bipolar signals to comply with the input requirements.

When a conversion takes place, the pseudo ground corresponds to 0 and the maximum analog input corresponds to 4096.

## Analog Input Structure

Figure 7 shows the equivalent circuit of the analog input structure of the AD7453. The four diodes provide ESD protection for the analog inputs. Care must be taken to ensure that the analog input signals never exceed the supply rails by more than  $300\text{mV}$ . This will cause these diodes to become forward biased and start conducting into the substrate. These diodes can conduct up to  $10\text{mA}$  without causing irreversible damage to the part. The capacitors  $C1$ , in figure 12 are typically  $4\text{pF}$  and can primarily be attributed to pin capacitance. The resistors are lumped components made up of the on-resistance of the switches. The value of these resistors is typically about  $100\Omega$ . The capacitors,  $C2$ , are the ADC's sampling capacitors and have a capacitance of  $16\text{pF}$  typically.

For ac applications, removing high frequency components from the analog input signal is recommended by the use of an RC low-pass filter on the relevant analog input pins. In applications where harmonic distortion and signal to noise ratio are critical, the analog input should be driven from a low impedance source. Large source impedances will significantly affect the ac performance of the ADC. This may necessitate the use of an input buffer amplifier. The choice of the opamp will be a function of the particular application.

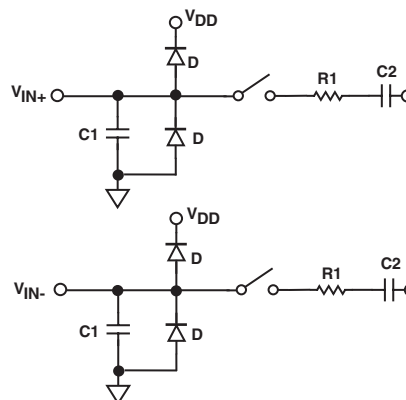

Figure 7. Equivalent Analog Input Circuit.  
Conversion Phase - Switches Open  
Track Phase - Switches Closed

When no amplifier is used to drive the analog input, the source impedance should be limited to low values. The maximum source impedance will depend on the amount of Total Harmonic Distortion (THD) that can be tolerated. The THD will increase as the source impedance increases and performance will degrade. Figure 8 shows a graph of

the THD versus analog input signal frequency for different source impedances.

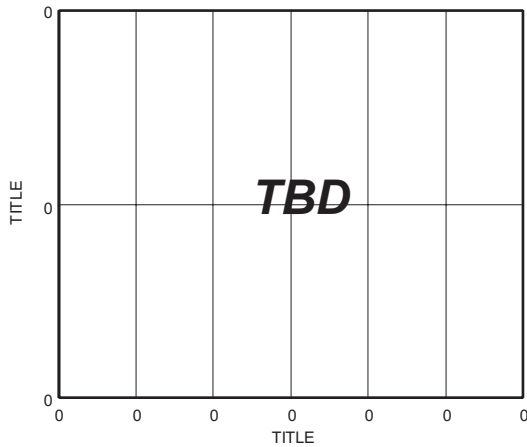

Figure 8. THD vs Analog Input Frequency for Various Source Impedances

Figure 9 shows a graph of THD versus analog input frequency for various supply voltages. In this case the source impedance is 10Ω.

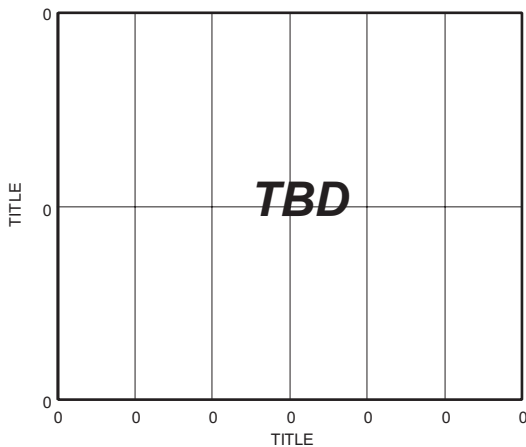

Figure 9. THD vs Analog Input Frequency for various Supply Voltages

**DIGITAL INPUTS**

The digital inputs applied to the AD7453 are not limited by the maximum ratings which limit the analog inputs. Instead the digital inputs applied i.e CS and SCLK, can go to 7 V and are not restricted by the  $V_{DD} + 0.3$  V limits as on the analog input.

The main advantage of the inputs not being restricted to the  $V_{DD} + 0.3$  V limit is the fact that power supply sequencing issues are avoided. If CS or SCLK are applied before  $V_{DD}$ , there is no risk of latch up as there would be on the analog inputs if a signal greater than 0.3 V were applied prior to  $V_{DD}$ .

**REFERENCE SECTION**

An external is required to supply the reference to the AD7453. This reference input can range from 100mV to 3.5 V. The specified reference is 2.5 V for the power supply range 2.7 V to 5.25 V. The reference input chosen for an application should never be greater than the power supply. Errors in the reference source will result in gain errors in the AD7453 transfer function and will add to the specified full-scale errors of the part. A capacitor of at least 0.1 μF should be placed on the  $V_{REF}$  pin. Suitable reference sources for the AD7453 include the AD780, the TBD and the TBD. Figure 10 shows a typical connection diagram for the  $V_{REF}$  pin.

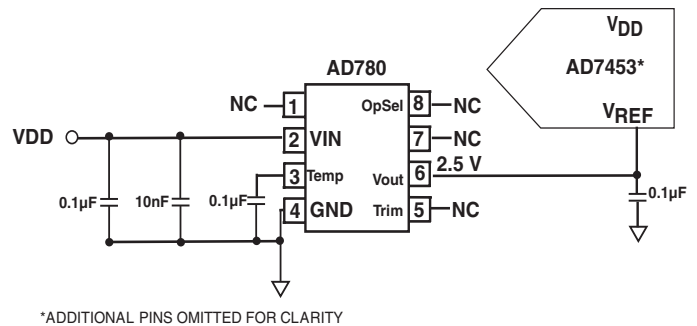

\*ADDITIONAL PINS OMITTED FOR CLARITY

Figure 10. Typical  $V_{REF}$  Connection Diagram for  $V_{DD} = 5$  V

**SERIAL INTERFACE**

Figure 1 shows a detailed timing diagram for the serial interface of the AD7453. The serial clock provides the conversion clock and also controls the transfer of data from the device during conversion. CS initiates the conversion process and frames the data transfer. The falling edge of CS puts the track and hold into hold mode and takes the bus out of three-state. The analog input is sampled and the conversion initiated at this point. The conversion will require 16 SCLK cycles to complete.

Once 13 SCLK falling edges have occurred, the track and hold will go back into track on the next SCLK rising edge as shown at point B in Figure 1. On the 16th SCLK falling edge the SDATA line will go back into three-state. If the rising edge of CS occurs before 16 SCLKs have elapsed, the conversion will be terminated and the SDATA line will go back into three-state on the 16th SCLK falling edge.

The conversion result from the AD7453 is provided on the SDATA output as a serial data stream. The bits are clocked out on the falling edge of the SCLK input. The data stream consists of four leading zeros, followed by 12 bits of conversion data which is provided MSB first. The output coding is straight (natural) binary.

16 serial clock cycles are required to perform a conversion and to access data from the AD7453. CS going low provides the first leading zero to be read in by the micro-controller or DSP. The remaining data is then clocked out on the subsequent SCLK falling edges beginning with the second

# AD7453

leading zero. Thus the first falling clock edge on the serial clock provides the second leading zero. The final bit in the data transfer is valid on the 16th falling edge, having been clocked out on the previous (15th) falling edge.

In applications with a slower SCLK, it may be possible to read in data on each SCLK rising edge i.e. the first rising edge of SCLK after the  $\overline{CS}$  falling edge would have the leading zero provided and the 15th SCLK edge would have DB0 provided.

## MODES OF OPERATION

The mode of operation of the AD7453 is selected by controlling the logic state of the  $\overline{CS}$  signal during a conversion. There are two possible modes of operation, Normal Mode and Power-Down Mode. The point at which  $\overline{CS}$  is pulled high after the conversion has been initiated will determine whether or not the AD7453 will enter the power-down mode. Similarly, if already in power-down,  $\overline{CS}$  controls whether the devices will return to normal operation or remain in power-down. These modes of operation are designed to provide flexible power management options. These options can be chosen to optimize the power dissipation/throughput rate ratio for differing application requirements.

### Normal Mode

This mode is intended for fastest throughput rate performance. The user does not have to worry about any power-up times with the AD7453 remaining fully powered up all the time. Figure 11 shows the general diagram of the operation of the AD7453 in this mode. The conversion is initiated on the falling edge of  $\overline{CS}$  as described in the 'Serial Interface Section'. To ensure the part remains fully powered up,  $\overline{CS}$  must remain low until at least 10 SCLK falling edges have elapsed after the falling edge of  $\overline{CS}$ .

If  $\overline{CS}$  is brought high any time after the 10th SCLK falling edge, but before the 16th SCLK falling edge, the part will remain powered up but the conversion will be terminated and SDATA will go back into three-state. Sixteen serial clock cycles are required to complete the conversion and access the complete conversion result.  $\overline{CS}$  may idle high until the next conversion or may idle low until sometime prior to the next conversion. Once a data transfer is complete, i.e. when SDATA has returned to three-state, another conversion can be initiated after the quiet time,  $t_{QUIET}$  has elapsed by again bringing  $\overline{CS}$  low.

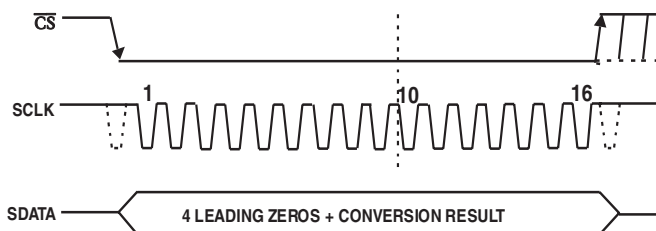

Figure 11. Normal Mode Operation

### Power Down Mode

This mode is intended for use in applications where slower throughput rates are required; either the ADC is powered down between each conversion, or a series of conversions may be performed at a high throughput rate and the ADC is then powered down for a relatively long duration between these bursts of several conversions. When the AD7453 is in the power down mode, all analog circuitry is powered down. To enter power down mode, the conversion process must be interrupted by bringing  $\overline{CS}$  high anywhere after the second falling edge of SCLK and before the tenth falling edge of SCLK as shown in Figure 12.

Once  $\overline{CS}$  has been brought high in this window of SCLKs, the part will enter power down and the conversion that was initiated by the falling edge of  $\overline{CS}$  will be terminated and SDATA will go back into three-state. The time from the rising edge of  $\overline{CS}$  to SDATA three-state enabled will never be greater than  $t_3$  (see the 'Timing Specifications'). If  $\overline{CS}$  is brought high before the second SCLK falling edge, the part will remain in normal mode and will not power-down. This will avoid accidental power-down due to glitches on the  $\overline{CS}$  line.

In order to exit this mode of operation and power the AD7453 up again, a dummy conversion is performed. On the falling edge of  $\overline{CS}$  the device will begin to power up, and will continue to power up as long as  $\overline{CS}$  is held low until after the falling edge of the 10th SCLK. The device will be fully powered up after 1µsec has elapsed and, as shown in Figure 13, valid data will result from the next conversion. If  $\overline{CS}$  is brought high before the 10th falling edge of SCLK, the AD7453 will again go back into power-down. This avoids accidental power-up due to glitches on the  $\overline{CS}$  line or an inadvertent burst of eight SCLK cycles while  $\overline{CS}$  is low. So although the device may begin to power up on the falling edge of  $\overline{CS}$ , it will again power-down on the rising edge of  $\overline{CS}$  as long as it occurs before the 10th SCLK falling edge.

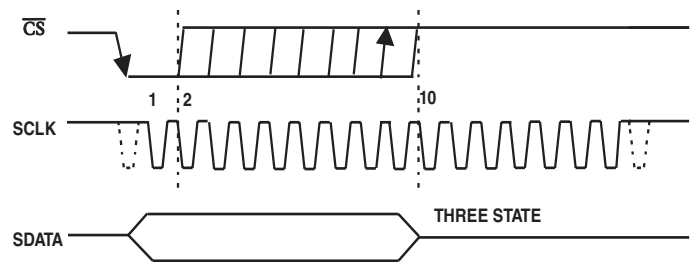

Figure 12. Entering Power Down Mode

### Power up Time

The power up time of the AD7453 is typically 1µsec, which means that with any frequency of SCLK up to 10MHz, one dummy cycle (1.6µsec) will always be sufficient to allow the device to power-up. Once the dummy cycle is complete, the ADC will be fully powered up and the input signal will be acquired properly. The quiet time  $t_{QUIET}$  must still be allowed from the point at which the bus goes back into three-state after the dummy conversion, to the next falling edge of  $\overline{CS}$ .

When running at the maximum throughput rate of 555kSPS, the AD7453 will power up and acquire a signal within  $\pm 0.5\text{LSB}$  in one dummy cycle, i.e.  $1.6\mu\text{sec}$ . When powering up from the power-down mode with a dummy cycle, as in Figure 13, the track and hold, which was in hold mode while the part was powered down, returns to track mode after the first SCLK edge the part receives after the falling edge of  $\overline{\text{CS}}$ . This is shown as point A in Figure 13.

Although at any SCLK frequency one dummy cycle is sufficient to power the device up and acquire  $V_{\text{IN}}$ , it does not necessarily mean that a full dummy cycle of 16 SCLKs must always elapse to power up the device and acquire  $V_{\text{IN}}$  fully;  $1\mu\text{s}$  will be sufficient to power the device up and acquire the input signal.

For example, if a 5MHz SCLK frequency was applied to the ADC, the cycle time would be  $3.2\mu\text{s}$  (i.e.  $1/(5\text{MHz}) \times 16$ ). In one dummy cycle,  $3.2\mu\text{s}$ , the part would be powered up and  $V_{\text{IN}}$  acquired fully. However after  $1\mu\text{s}$  with a 5MHz SCLK only 5 SCLK cycles would have elapsed. At this stage, the ADC would be fully powered up and the signal acquired. So, in this case the  $\overline{\text{CS}}$  can be brought high after the 10th SCLK falling edge and brought low again after a time  $t_{\text{QUIET}}$  to initiate the conversion.

When power supplies are first applied to the AD7453, the ADC may either power up in the power-down mode or normal mode. Because of this, it is best to allow a dummy cycle to elapse to ensure the part is fully powered up before attempting a valid conversion. Likewise, if the user wishes the part to power up in power-down mode, then the dummy cycle may be used to ensure the device is in power-down by executing a cycle such as that shown in Figure 12.

Once supplies are applied to the AD7453, the power up time is the same as that when powering up from the power-down mode. It takes approximately  $1\mu\text{s}$  to power up fully if the part powers up in normal mode. It is not necessary to wait  $1\mu\text{s}$  before executing a dummy cycle to ensure the desired mode of operation. Instead, the dummy cycle can occur directly after power is supplied to the ADC. If the first valid conversion is then performed di-

rectly after the dummy conversion, care must be taken to ensure that adequate acquisition time has been allowed.

As mentioned earlier, when powering up from the power-down mode, the part will return to track upon the first SCLK edge applied after the falling edge of  $\overline{\text{CS}}$ . However, when the ADC powers up initially after supplies are applied, the track and hold will already be in track. This means if (assuming one has the facility to monitor the ADC supply current) the ADC powers up in the desired mode of operation and thus a dummy cycle is not required to change mode, then neither is a dummy cycle required to place the track and hold into track.

#### MICROPROCESSOR AND DSP INTERFACING

The serial interface on the AD7453 allows the part to be directly connected to a range of different microprocessors. This section explains how to interface the AD7453 with some of the more common microcontroller and DSP serial interface protocols.

#### AD7453 to ADSP21xx

The ADSP21xx family of DSPs are interfaced directly to the AD7453 without any glue logic required.

The SPORT control register should be set up as follows:

TFSW = RFSW = 1, Alternate Framing

INVRFS = INVTFS = 1, Active Low Frame Signal

DTYPE = 00, Right Justify Data

SLEN = 1111, 16-Bit Data words

ISCLK = 1, Internal serial clock

TFSR = RFSR = 1, Frame every word

IRFS = 0,

ITFS = 1.

To implement the power-down mode SLEN should be set to 1001 to issue an 8-bit SCLK burst.

The connection diagram is shown in Figure 14. The ADSP21xx has the TFS and RFS of the SPORT tied together, with TFS set as an output and RFS set as an input. The DSP operates in Alternate Framing Mode and the SPORT control register is set up as described. The Frame Synchronisation signal generated on the TFS is tied to  $\overline{\text{CS}}$  and as with all signal processing applications equidistant sampling is necessary. However, in this example, the timer interrupt is used to control the sampling rate of the ADC and under certain conditions, equidistant sampling may not be achieved.

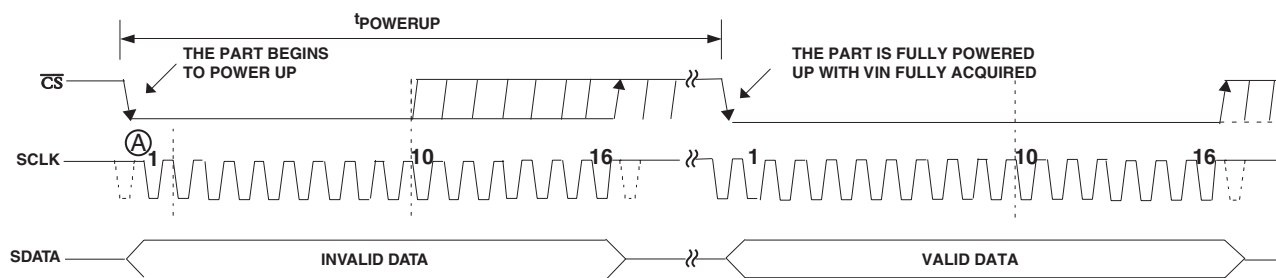

Figure 13. Exiting Power Down Mode



# AD7453

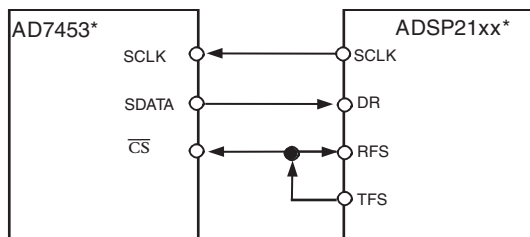

Figure 14. Interfacing to the ADSP 21xx

The timer registers etc., are loaded with a value which will provide an interrupt at the required sample interval. When an interrupt is received, a value is transmitted with TFS/DT (ADC control word). The TFS is used to control the RFS and hence the reading of data. The frequency of the serial clock is set in the SCLKDIV register. When the instruction to transmit with TFS is given, (i.e. AX0=TX0), the state of the SCLK is checked. The DSP will wait until the SCLK has gone High, Low and High before transmission will start. If the timer and SCLK values are chosen such that the instruction to transmit occurs on or near the rising edge of SCLK, then the data may be transmitted or it may wait until the next clock edge. For example, the ADSP-2111 has a master clock frequency of 16MHz. If the SCLKDIV register is loaded with the value 3 then a SCLK of 2MHz is obtained, and 8 master clock periods will elapse for every 1 SCLK period. If the timer registers are loaded with the value 803, then 100.5 SCLKs will occur between interrupts and subsequently between transmit instructions. This situation will result in non-equidistant sampling as the transmit instruction is occurring on a SCLK edge. If the number of SCLKs between interrupts is a whole integer figure of N then equidistant sampling will be implemented by the DSP.

## AD7453 to TMS320C5x/C54x

The serial interface on the TMS320C5x/C54x uses a continuous serial clock and frame synchronization signals to synchronize the data transfer operations with peripheral devices like the AD7453. The CS input allows easy interfacing between the TMS320C5x/C54x and the AD7453 without any glue logic required. The serial port of the TMS320C5x/C54x is set up to operate in burst mode with internal CLKX (TX serial clock) and FSX (TX frame sync). The serial port control register (SPC) must have the following setup: FO = 0, FSM = 1, MCM = 1 and TXM = 1. The format bit, FO, may be set to 1 to set the word length to 8-bits, in order to implement the power-down mode on the AD7453. The connection diagram is shown in Figure 15. It should be noted that for signal processing applications, it is imperative that the frame synchronisation signal from the TMS320C5x/C54x will provide equidistant sampling.

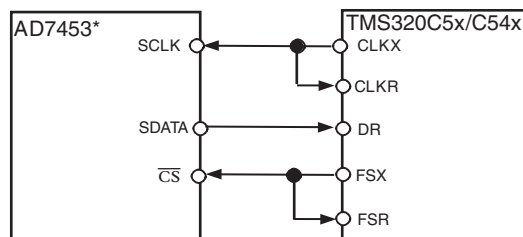

Figure 15. Interfacing to the TMS320C5x/C54x

## AD7453 to MC68HC16

The Serial Peripheral Interface (SPI) on the MC68HC16 is configured for Master Mode (MSTR = 1), Clock Polarity Bit (CPOL) = 1 and the Clock Phase Bit (CPHA) = 0. The SPI is configured by writing to the SPI Control Register (SPCR) - see 68HC16 user manual. The serial transfer will take place as a 16-bit operation when the SIZE bit in the SPCR register is set to SIZE = 1. To implement the power-down modes with an 8-bit transfer set SIZE = 0. A connection diagram is shown in figure 16.

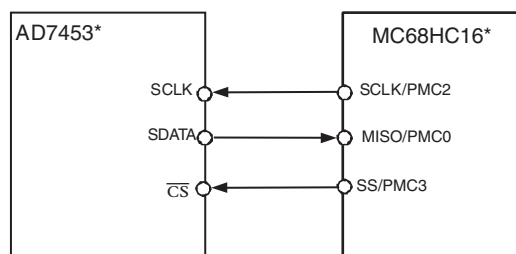
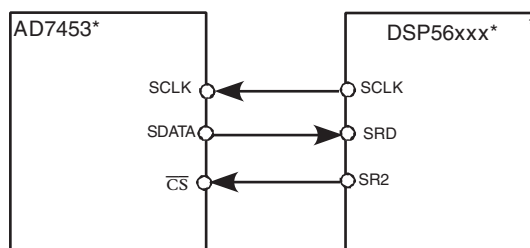

Figure 16. Interfacing to the MC68HC16

## AD7453 to DSP56xxx

The connection diagram in figure 17 shows how the AD7453 can be connected to the SSI (Synchronous Serial Interface) of the DSP56xxx family of DSPs from Motorola. The SSI is operated in Synchronous Mode (SYN bit in CRB =1) with internally generated 1-bit clock period frame sync for both Tx and Rx (bits FSL1 =1 and FSL0 =0 in CRB). Set the word length to 16 by setting bits WL1 =1 and WL0 = 0 in CRA. To implement the power-down mode on the AD7453 then the word length can be changed to 8 bits by setting bits WL1 = 0 and WL0 = 0 in CRA. It should be noted that for signal processing applications, it is imperative that the frame synchronisation signal from the DSP56xxx will provide equidistant sampling.



\*ADDITIONAL PINS OMITTED FOR CLARITY

Figure 17. Interfacing to the DSP56xx

## APPLICATION HINTS

### Grounding and Layout

The printed circuit board that houses the AD7453 should be designed so that the analog and digital sections are separated and confined to certain areas of the board. This facilitates the use of ground planes that can be easily separated. A minimum etch technique is generally best for ground planes as it gives the best shielding. Digital and analog ground planes should be joined in only one place and the connection should be a star ground point established as close to the GND pin on the AD7453 as possible.

Avoid running digital lines under the device as this will couple noise onto the die. The analog ground plane should be allowed to run under the AD7453 to avoid noise coupling. The power supply lines to the AD7453 should use as large a trace as possible to provide low impedance paths and reduce the effects of glitches on the power supply line.

Fast switching signals like clocks should be shielded with digital ground to avoid radiating noise to other sections of the board, and clock signals should never run near the analog inputs. Avoid crossover of digital and analog signals. Traces on opposite sides of the board should run at right angles to each other. This will reduce the effects of feedthrough through the board. A microstrip technique is by far the best but is not always possible with a double-sided board.

In this technique the component side of the board is dedicated to ground planes while signals are placed on the solder side. Good decoupling is also important. All analog supplies should be decoupled with 10 $\mu$ F tantalum capacitors in parallel with 0.1 $\mu$ F capacitors to GND. To achieve the best from these decoupling components, they must be placed as close as possible to the device.

OUTLINE DIMENSIONS

Dimensions shown in inches (millimeters)

8-LEAD SOT-23 (RT-8)

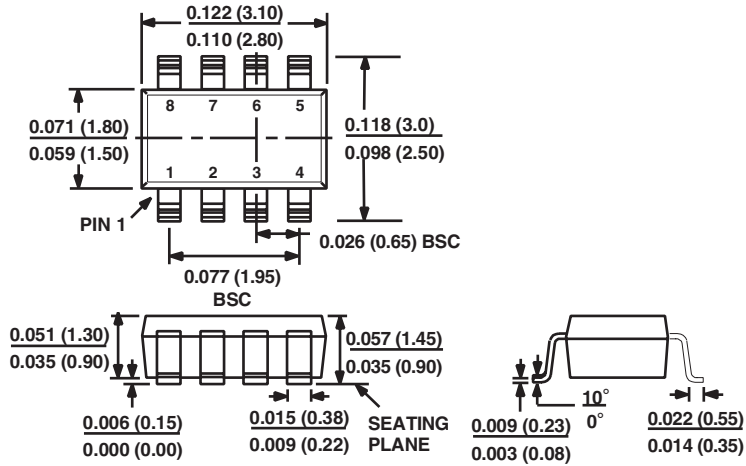

8-LEAD MSOP (RM-8)

