



550kSPS 16-BIT Differential ADC in μ SO

Preliminary Technical Data

AD7688*

FEATURES

16 Bits Resolution with No Missing 16-Bit Codes

Throughput:

550 kSPS (Warp mode)

450 kSPS (Normal mode)

380 kSPS (Impulse mode)

INL: ± 1.5 LSB Max (± 0.0023 % of Full-Scale)

S/(N+D): 93 dB Typ @ 10 kHz

THD: -100 dB Typ @ 10 kHz

Pseudo-Differential Analog input range: $\pm V_{REF}$

0V to V_{REF} with V_{REF} up to VDD on Both Inputs

No Pipeline Delay

Single Supply Operation 5V and 2.7V

with 2.5V/3V/5V logic interface

Multiple ADCs Daisy Chain and Busy Indicator

Programmable Input Bandwidth

Serial Interface SPI/QSPI/ μ Wire/DSP compatible

30 mW @ 5V/380kSPS, 18mW @ 3V/380kSPS Typical

Power Dissipation,

80 μ W @ 5V/1 kSPS

Stand-by current (acquisition phase): 1 μ A Max

μ -SOIC Package (μ -SO8 size)

Pin-to-Pin Compatible with the AD7685, AD7686, AD7687

Battery Powered Equipment

Data Acquisition

Instrumentation

Medical Instruments

Process Control

GENERAL DESCRIPTION

The AD7688 is a 16-bit, 550 kSPS, charge redistribution successive-approximation, truly differential Analog-to-Digital Converter which operates from a single power supply. It contains a high-speed 16-Bit sampling ADC without any missing code, an internal conversion clock, error correction circuits, and a flexible serial interface port. The part also contains a low noise, wide bandwidth, very short aperture delay track/hold circuit which can sample a \pm REF analog input range. The reference voltage REF is applied externally and can be set up to the supply voltage.

It features a very high sampling rate mode (Warp) and, for asynchronous conversion rate applications, a fast mode (Normal) and, for low power applications, a reduced

*Patent pending.

REV. Pr G

Information furnished by Analog Devices is believed to be accurate and reliable. However, no responsibility is assumed by Analog Devices for its use, nor for any infringements of patents or other rights of third parties which may result from its use. No license is granted by implication or otherwise under any patent or patent rights of Analog Devices.

FUNCTIONAL BLOCK DIAGRAM

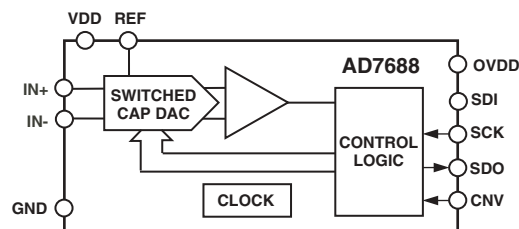

μ SO/SOT23 16 Bit ADC

Type / kSPS	100 kSPS	250 kSPS	380 - 550 kSPS
True Differential	AD7684	AD7687	AD7688
Pseudo Differential	AD7683	AD7685	AD7686
Unipolar	AD7680		

power mode (Impulse) where the power is scaled with the throughput.

The serial interface features the possibility to “Daisy chain” several ADCs on a single 3 wires bus and provides an optional Busy indicator.

The AD7688 is hardware factory calibrated. It is fabricated using CMOS process and is housed in 10-lead μ SOIC package with operation specified from -40°C to $+85^{\circ}\text{C}$.

PRODUCT HIGHLIGHTS

1. Superior INL

The AD7688 has a maximum integral non linearity of 1.5 LSB with no missing 16-bit code.

2. Fast Throughput.

The AD7688 is a very high speed (550 kSPS in Warp mode and 450 kSPS in Normal mode), charge redistribution, 16-Bit SAR ADC with no pipeline delay.

3. 2.7V or 5V Single Supply Operation

The AD7688 operates from a single supply, dissipates only 18 mW typical at 380kSPS (Impulse), and even lower when a reduced throughput is used. It consumes 1 μ A maximum during the acquisition phase.

4. Serial Interface with OVDD, Daisy Chain and Busy Indicator
2.5V, 3 V or 5 V logic 3-wire serial interface arrangement compatible with SPI and DSP host.

PRELIMINARY TECHNICAL DATA

AD7688—SPECIFICATIONS

($T_A = -40^\circ\text{C}$ to $+85^\circ\text{C}$, $V_{REF} = 5\text{V}$, $V_{DD} = 5\text{V}$, $OV_{DD} = 2.3\text{V}$ to 5.25V , unless otherwise noted.)

Parameter	Conditions	Min	Typ	Max	Unit
RESOLUTION		16			Bits
ANALOG INPUT					
Voltage Range	IN+ - IN-	$-V_{REF}$		$+V_{REF}$	V
Absolute Input Voltage	IN+	-0.1		$V_{DD} + 0.3$	V
	IN-	-0.1		$V_{DD} + 0.3$	V
Analog Input CMRR	$f_{IN} = \text{TBD kHz}$		TBD		dB
Leakage Current at 25 °C	550kSPS Throughput		TBD		nA
Input Impedance			See Analog Input Section		
THROUGHPUT SPEED					
Complete Cycle	In Warp Mode			1.8	μs
Throughput Rate	In Warp Mode	1		550	kSPS
Complete Cycle	In Normal Mode			2.2	μs
Throughput Rate	In Normal Mode	0		450	kSPS
Complete Cycle	In Impulse Mode			2.6	μs
Throughput Rate	In Impulse Mode	0		380	kSPS
DC ACCURACY					
No Missing Codes		16			Bits
Integral Linearity Error		-1.5	± 1	+1.5	LSB ¹
Transition Noise			0.4		LSB
Gain Error ² , T_{MIN} to T_{MAX}	REF = 5 V			$\pm\text{TBD}$	% of FSR
Gain Error Temperature Drift			$\pm\text{TBD}$		ppm/ $^\circ\text{C}$
Offset Error ² , T_{MIN} to T_{MAX}			$\pm\text{TBD}$	$\pm\text{TBD}$	LSB
Offset Temperature Drift			$\pm\text{TBD}$		ppm/ $^\circ\text{C}$
Power Supply Sensitivity	VDD = 5 V \pm 5%		$\pm\text{TBD}$		LSB
AC ACCURACY					
Signal-to-Noise	$f_{IN} = \text{TBD kHz}$	92	93		dB ³
Spurious Free Dynamic Range	$f_{IN} = \text{TBD kHz}$		100		dB
Total Harmonic Distortion	$f_{IN} = \text{TBD kHz}$		-100	TBD	dB
Signal-to-(Noise+Distortion)	$f_{IN} = \text{TBD kHz}$	92	93		dB
	$f_{IN} = \text{TBD kHz}, -60\text{ dB Input}$		33		dB
Intermodulation Distortion			TBD		dB
Second Order Terms			TBD		dB
Third Order Terms			2		MHz
-3 dB Input Bandwidth	Bandwidth Limit on Bandwidth Limit off		9		MHz
SAMPLING DYNAMICS					
Aperture Delay			TBD		ns
Aperture Jitter			TBD		ps rms
Transient Response	Full-Scale Step			400	ns
REFERENCE					
External Reference Voltage Range		0.5		$V_{DD} + 0.3$	V
External Reference Current Drain	550kSPS Throughput		TBD		μA
DIGITAL INPUTS					
Logic Levels					
V_{IL}		-0.3		+0.8	V
V_{IH}	OVDD = 2.7V to 5.25V	+2.0		$OV_{DD} + 0.3$	V
	OVDD = 2.3V to 5.25V	+1.7		$OV_{DD} + 0.3$	V
I_{IL}		-1		+1	μA
I_{IH}		-1		+1	μA
DIGITAL OUTPUTS					
Data Format			Serial 16-Bits Twos's Complement		
Pipeline Delay			Conversion Results Available Immediately		
			After Completed Conversion		
V_{OL}	$I_{SINK} = 500\ \mu\text{A}$			0.4	V
V_{OH}	$I_{SOURCE} = -500\ \mu\text{A}$	OVDD - 0.3			V

NOTES

¹LSB means Least Significant Bit. With the 5 V input range, one LSB is 152.6 μV .

²See Definition of Specifications section. These specifications do include full temperature range variation but do not include the error contribution from the external reference.

³All specifications in dB are referred to a full-scale input FS. Tested with an input signal at 0.5 dB below full-scale unless otherwise specified.

Specifications subject to change without notice.

Parameter	Conditions	Min	Typ	Max	Unit
POWER SUPPLIES					
VDD	Specified Performance	4.75	5	5.25	V
VDD Range		2.7		5.25	V
OVDD		2.7		5.25	V
Operating Current	550 kSPS Throughput ⁴				
VDD	VDD = 5V		T B D		m A
OVDD			T B D		μ A
Power Dissipation (VDD = 5V)	380 kSPS Throughput ⁵		30	T B D	m W
	1 kSPS Throughput ⁵		80		μ W
	During acquisition phase ⁵			T B D	μ W
	550 kSPS Throughput ⁴		44	T B D	m W
TEMPERATURE RANGE ⁶					
Specified Performance	T _{MIN} to T _{MAX}	-40		+85	°C

NOTES

⁴In Warp mode.⁵In Impulse mode. With all digital inputs forced to OVDD or GND respectively.⁶Contact factory for extended temperature range.

Specifications subject to change without notice.

TIMING SPECIFICATIONS (-40°C to +85°C, VDD = 4.75 V to 5.25V, OVDD = 2.7 V to 5.25 V, unless otherwise stated)

	Symbol	Min	Typ	Max	Unit
Conversion Time: CNV Rising Edge to Data available (Warp mode / Normal mode / Impulse mode)	t _{CONV}	0.7/0.9/1.1		1.4/1.8/2.2	μ s
Acquisition Time	t _{ACQ}	400			ns
Time Between Conversions	t _{CYC}	1.8/2.2/2.6		note 1	μ s
CNV Pulse width (\overline{CS} mode)	t _{CNVH}	5			ns
SCK Period	t _{SCK}	15			ns
SCK Low Time	t _{SCKH}	7			ns
SCK High Time	t _{SCKL}	7			ns
SCK Falling Edge to Data remains Valid	t _{HSDO}	5			ns
SCK Falling Edge to Data Valid delay	t _{DSDO}				
OVDD above 4.75V				13	ns
OVDD above 3V				20	ns
OVDD above 2.7V				27	ns
CNV or SDI Low to SDO D15 MSB Valid (\overline{CS} mode)	t _{EN}				
OVDD above 4.75V				15	ns
OVDD above 2.7V				30	ns
CNV or SDI High or last SCK Falling Edge to SDO High Impedance (\overline{CS} mode)	t _{DIS}			30	ns
SDI valid Setup Time from CNV rising edge (\overline{CS} mode)	t _{SSDICNV}	8			ns
SDI valid Hold Time from CNV rising edge (\overline{CS} mode)	t _{HSDICNV}	0			ns
SCK valid Setup Time from CNV rising edge (Chain mode)	t _{SSCKCNV}	8			ns
SCK valid Hold Time from CNV rising edge (Chain mode)	t _{HSCKCNV}	5			ns
SDI valid Setup Time from SCK falling edge (Chain mode)	t _{SSDISCK}	8			ns
SDI valid Hold Time from SCK falling edge (Chain mode)	t _{HSDISCK}	0			ns
SDI High to SDO High (Chain mode with Busy indicator)	t _{DSDOSDI}				
OVDD above 4.75V				15	ns
OVDD above 2.7V				30	ns

NOTES

¹In Warp mode, the maximum time between conversion is 1ms; otherwise, there is no required maximum time.

Specifications subject to change without notice.

AD7688—SPECIFICATIONS

ABSOLUTE MAXIMUM RATINGS¹

Analog Inputs
 IN+², IN-, REF, GND -0.3 V to VDD + 0.3 V
 Supply Voltages
 VDD, OVDD to GND -0.3 V to 7 V
 VDD to OVDD ±7 V
 Digital Inputs to GND -0.3 V to OVDD + 0.3 V
 Digital Outputs to GND -0.3 V to OVDD + 0.3 V

Internal Power Dissipation³ 325 mW
 Junction Temperature 150°C
 Storage Temperature Range -65°C to +150°C
 Lead Temperature Range
 (Soldering 10 sec) 300°C

NOTES

¹Stresses above those listed under Absolute Maximum Ratings may cause permanent damage to the device. This is a stress rating only; functional operation of the device at these or any other conditions above those indicated in the operational section of this specification is not implied. Exposure to absolute maximum rating conditions for extended periods may affect device reliability.

²See Analog Input section.

³Specification is for device in free air: $\mu\text{SOIC-10}$: $\theta_{JA} = 200^\circ\text{C/W}$.

ORDERING GUIDE

Model	Temperature Range	Package Description	Package Option	Brand
AD7688BRM	-40°C to +85°C	$\mu\text{SOIC-10}$	RM-10	
AD7688BRMRL7	-40°C to +85°C	$\mu\text{SOIC-10}$	RM-10 (reel)	
EVAL-AD7688CB ¹		Evaluation Board		
EVAL-CONTROL BRD ²		Controller Board		
EVAL-CONTROL BRD ³		Controller Board		

NOTES

¹This board can be used as a standalone evaluation board or in conjunction with the EVAL-CONTROL BRDx for evaluation/demonstration purposes.

²These boards allow a PC to control and communicate with all Analog Devices evaluation boards ending in the CB designators.

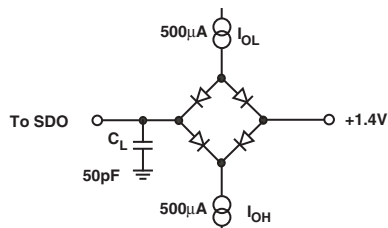

Figure 1. Load Circuit for Digital Interface Timing.

AD7688 PIN CONFIGURATION

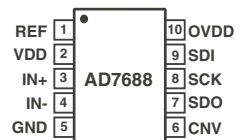

Figure 2. Voltage Reference Levels for Timing.

CAUTION

ESD (electrostatic discharge) sensitive device. Electrostatic charges as high as 4000 V readily accumulate on the human body and test equipment and can discharge without detection. Although the AD7688 features proprietary ESD protection circuitry, permanent damage may occur on devices subjected to high-energy electrostatic discharges. Therefore, proper ESD precautions are recommended to avoid performance degradation or loss of functionality.

REV. Pr G



PIN FUNCTION DESCRIPTIONS

Pin #	Mnemonic		Function
1	REF	AI	Reference Input Voltage. The REF range is from TBD to VDD. It is referred to the GND ground. This pin should be decoupled closely to the pin with a TBD μ F capacitor.
2	VDD	P	Input Power Supply.
3	IN+	AI	Differential Positive Analog Input.
4	IN-	AI	Differential Negative Analog Input Ground.
5	GND	P	Power Supply Ground.
6	CNV	DI	Convert Input. This input has multiple functions. On its leading edge, it initiates the conversions, it selects the interface mode of the part, Chain or $\overline{\text{CS}}$ mode, and in chain mode, it enables the busy indicator feature if SCK is high. In $\overline{\text{CS}}$ mode, it can enable the serial output signal when low. In Chain mode, the data should be read when CNV is high.
7	SDO	DO	Serial Data Output. The conversion result or the programming configuration word are output on this pin. It is synchronized to SCK.
8	SCK	DI	Serial Data Clock Input. When the part is selected, the conversion result is shifted out by this clock. If less than 16 pulses are applied when the part is selected, the programming configuration is updated.
9	SDI	DI	Serial Data Input. This input provides multiple features. It selects the interface mode of the ADC as follows: The Chain mode is selected if SDI is low during the CNV rising edge. In this Chain mode, SDI could be used as a data input to daisy chain the conversion results from two or more ADCs onto a single SDO line. The digital data level on SDI is output on SDO with a delay of 16 SCK cycles. The $\overline{\text{CS}}$ mode is selected if SDI is high during the CNV rising edge. In this $\overline{\text{CS}}$ mode, either SDI or CNV can enable the serial output signals when low and if SDI or CNV is low when the conversion is complete, the busy indicator feature is enabled.
10	OVDD	P	Input/Output Interface Digital Power. Nominally at the same supply than the host interface (2.5V, 3V or 5V).

NOTES

AI = Analog Input
DI = Digital Input
DO = Digital Output
P = Power

AD7688**DEFINITION OF SPECIFICATIONS****INTEGRAL NONLINEARITY ERROR (INL)**

Linearity error refers to the deviation of each individual code from a line drawn from “negative full scale” through “positive full scale”. The point used as “negative full scale” occurs 1/2 LSB before the first code transition. “Positive full scale” is defined as a level 1 1/2 LSB beyond the last code transition. The deviation is measured from the middle of each code to the true straight line.

DIFFERENTIAL NONLINEARITY ERROR (DNL)

In an ideal ADC, code transitions are 1 LSB apart. Differential nonlinearity is the maximum deviation from this ideal value. It is often specified in terms of resolution for which no missing codes are guaranteed.

GAIN ERROR

The last transition (from 111...10 to 111...11) should occur for an analog voltage 1 1/2 LSB below the nominal full scale (4.999886 V for the 0 V to 5 V range). The gain error is the deviation of the actual level of the last transition from the ideal level after the offset has been adjusted out.

OFFSET ERROR

The first transition should occur at a level 1/2 LSB above analog ground (38.1 μ V for the 0 V to 5 V range). The offset error is the deviation of the actual transition from that point.

SPURIOUS FREE DYNAMIC RANGE (SFDR)

The difference, in decibels (dB), between the rms amplitude of the input signal and the peak spurious signal.

EFFECTIVE NUMBER OF BITS (ENOB)

ENOB is a measurement of the resolution with a sine wave input. It is related to $S/(N+D)$ by the following formula:

$$\text{ENOB} = (S/[N+D]_{\text{dB}} - 1.76)/6.02$$

and is expressed in bits.

TOTAL HARMONIC DISTORTION (THD)

THD is the ratio of the rms sum of the first five harmonic components to the rms value of a full-scale input signal and is expressed in decibels.

SIGNAL-TO-NOISE RATIO (SNR)

SNR is the ratio of the rms value of the actual input signal to the rms sum of all other spectral components below the Nyquist frequency, excluding harmonics and dc. The value for SNR is expressed in decibels.

SIGNAL TO (NOISE + DISTORTION) RATIO (S/[N+D])

$S/(N+D)$ is the ratio of the rms value of the actual input signal to the rms sum of all other spectral components below the Nyquist frequency, including harmonics but excluding dc. The value for $S/(N+D)$ is expressed in decibels.

APERTURE DELAY

Aperture delay is a measure of the acquisition performance and is measured from the rising edge of the CNV input to when the input signal is held for a conversion.

TRANSIENT RESPONSE

The time required for the AD7688 to achieve its rated accuracy after a full-scale step function is applied to its input.

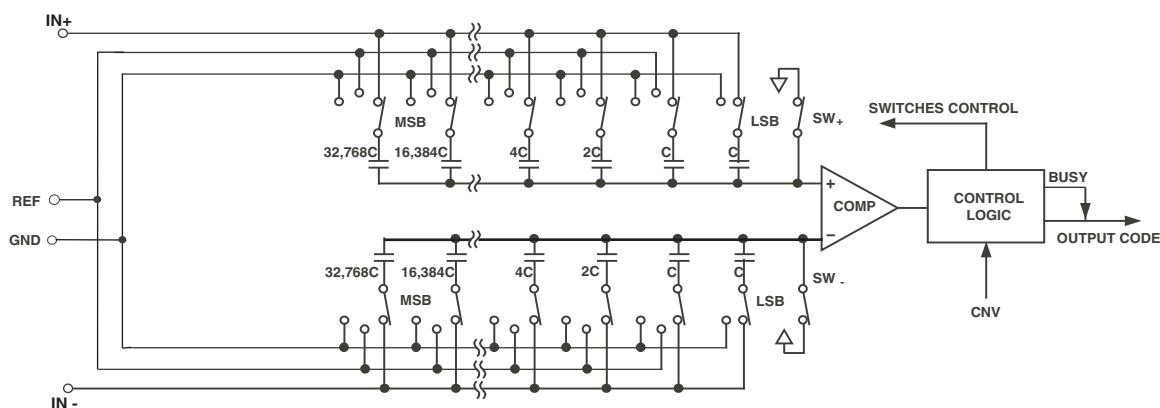

Figure 3. ADC Simplified Schematic

CIRCUIT INFORMATION

The AD7688 is a fast, low-power, single-supply, precise 16-bit analog-to-digital converter (ADC) using successive approximation architecture.

The AD7688 features different modes to optimize performances according to the applications.

In Warp mode, the AD7688 is capable of converting 550,000 samples per second (550 kSPS).

In Impulse mode, the AD7688 is capable of converting 380,000 samples per second (380 kSPS) and allow power saving between conversions. When operating at 1kSPS, for example, it consumes typically 48 μW with a 3V supply, ideal for battery-powered applications.

The AD7688 provides the user with an on-chip track/hold, successive approximation ADC that does not exhibit any pipeline or latency, making it ideal for multiple multiplexed channel applications.

The AD7688 can be operated from a single 2.7 V to 5.5V supply and be interfaced to either 5 V or 3.3 V or 2.5 V digital logic. It is housed in a 10-lead μSO package that combines space savings and allows flexible configurations. The AD7688 is pin-to-pin-compatible with the AD7685, the AD7686 and the AD7687.

The CNV rising edge is used as a sampling edge. It puts the track and hold in hold position and initiates the conversion process. Because the AD7688 has an on board conversion clock, the serial clock SCK is not required for the conversion process. When the conversion is complete and whatever the CNV state is, the part returns automatically in a power-down mode with the track and hold in track position.

CONVERTER OPERATION

The AD7688 is a successive approximation analog-to-digital converter based on a charge redistribution DAC. Figure 3 shows the simplified schematic of the ADC. The capacitive DAC consists of two identical arrays of 16 binary weighted capacitors which are connected to the two comparator inputs.

During the acquisition phase, terminals of the array tied to the comparator's input are connected to GND via SW₊ and SW₋. All independent switches are connected to the analog inputs. Thus, the capacitor arrays are used as sampling capacitors and acquire the analog signal on IN₊ and IN₋ inputs. When the acquisition phase is complete and the CNV input goes high, a conversion phase is initiated. When the conversion phase begins, SW₊ and SW₋ are opened first. The two capacitor arrays are then disconnected from the inputs and connected to the GND input. Therefore, the differential voltage between the inputs IN₊ and IN₋ captured at the end of the acquisition phase is applied to the comparator inputs, causing the comparator to become unbalanced. By switching each element of the capacitor array between GND or REF, the comparator input varies by binary weighted voltage steps ($V_{\text{REF}}/2$, $V_{\text{REF}}/4 \dots V_{\text{REF}}/65536$). The control logic toggles these switches, starting with the MSB first, in order to bring the comparator back into a balanced condition. After the completion of this process, the control logic generates the ADC output code and a BUSY signal indicator.

Modes of Operation

The AD7688 features three modes of operations, Warp, Normal, and Impulse. Each of these modes is more suitable for specific applications.

The Warp mode allows the fastest conversion rate up to 550 kSPS. However, in this mode, and this mode only, the full specified accuracy is guaranteed only when the time between conversion does not exceed 1 ms. If the time between two consecutive conversions is longer than 1 ms, for instance, after power-up, the first conversion result should be ignored. This mode makes the AD7688 ideal for applications where fast sample rate are required.

The normal mode is the fastest mode (450 kSPS) without any limitation about the time between conversions. This mode makes the AD7688 ideal for asynchronous applications such as data acquisition systems, where both high accuracy and fast sample rate are required.

The impulse mode, the lowest power dissipation mode, allows power saving between conversions. The maximum throughput in this mode is 380 kSPS. When operating at

AD7688

1 kSPS, for example, it typically consumes only 48 μ W. This feature makes the AD7688 ideal for battery-powered applications.

Transfer Functions

The ideal transfer characteristic for the AD7688 is shown in Figure 4 and Table I.

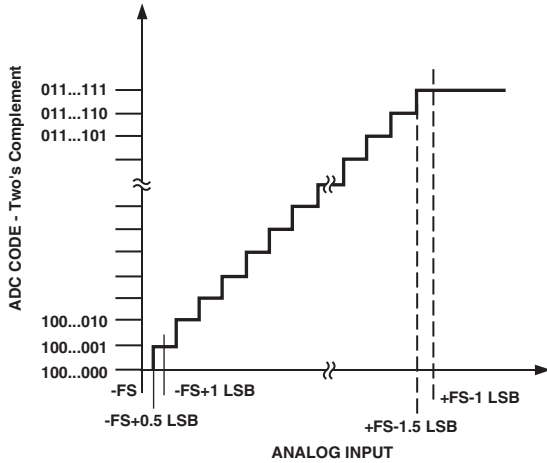

Figure 4. ADC Ideal Transfer Function

Table I. Output Codes and Ideal Input Voltages

Description	Analog Input $V_{REF} = 5V$	Digital Output Code Hexa
FSR -1 LSB	4.999847 V	7FFF ¹
Midscale + 1 LSB	152.6 μ V	0001
Midscale	0 V	0000
Midscale - 1 LSB	-152.6 μ V	FFFF
-FSR + 1 LSB	-4.999847 V	8001
-FSR	-5 V	8000 ²

NOTES

¹This is also the code for overrange analog input ($V_{IN+} - V_{IN-}$ above $V_{REF} - V_{GND}$).

²This is also the code for underrange analog input ($V_{IN+} - V_{IN-}$ below $V_{GND} - V_{REF}$).

DIGITAL INTERFACE

Though the AD7688 has a reduced number of pins, it offers flexibility in its serial interface modes:

The AD7688, used in “ \overline{CS} mode”, is compatible to SPI, QSPI digital hosts and DSPs (e.g.:Blackfin ADSP-BF53x or ADSP-219x). This interface can use either 3 or 4 wires. Three wires interface using CNV, SCK and SDO signals, minimizes wiring connections useful, for instance, in isolated applications. Four wires interface using SDI, CNV, SCK and SDO signals allows CNV, used to initiate the conversions, to be independent of the reading timing (SDI). That is useful in, low jitter sampling or simultaneous sampling applications.

The AD7688, used in “Chain mode”, provides a “daisy chain” feature using the SDI input for cascading multiple ADCs on a single data line.

The mode in which the part operates depends on the SDI level when the CNV rising edge occurs. The \overline{CS} mode is selected if SDI is high and the chain mode is selected if SDI is low. The SDI hold time is such that when SDI and CNV are connected together, the chain mode is always selected.

The AD7688 also offers the possibility, as an option and with both modes, to force a start bit in front of the 16 data bits. This start bit can be used as a busy signal indicator to interrupt the digital host and trigger the data reading.

The busy indicator is output or not depending on the mode as follows:

In \overline{CS} mode, the busy indicator occurs if CNV or SDI is low when the ADC conversion ends.

In Chain mode, the busy indicator will be outputted if SCK is high during the CNV rising edge.

\overline{CS} MODE 3 wires without Busy indicator

This mode is usually used when a single AD7688 is connected to an SPI compatible digital host. The connection diagram is shown in figure 5 and the corresponding timing is given in figure 6.

With SDI tied to OVDD, a rising edge on CNV initiates a conversion, selects the \overline{CS} mode and forces SDO in high impedance. Once a conversion is initiated, it will be processed until completion whatever the state of CNV is. For instance, it could be useful to bring CNV low to select other SPI devices such as analog multiplexers but CNV must be returned high before the minimum conversion time and held high until the maximum conversion time to avoid the generation of the busy signal indicator. When the conversion is complete, the AD7688 enters in acquisition phase and in reduced power mode. When CNV goes low, the MSB is output on SDO. The remaining data bits are then clocked by subsequent SCK driving edges. the driving edge can be either the falling or rising depending how the part is programmed. The data is valid on both SCK edges. Although the opposite edge of the driving edge can be used to capture the data, a digital host with acceptable hold time using also the SCK driving edge will allow a faster reading rate. After the 16th SCK driving edge or when CNV goes high, whichever is the earliest, SDO returns to high impedance.

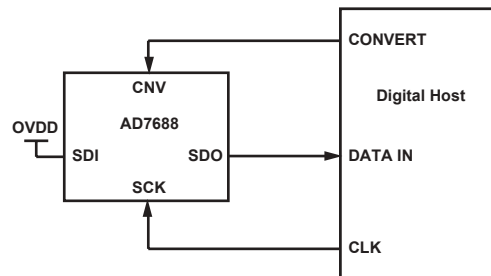

Figure 5. \overline{CS} mode 3 wires without busy indicator Connection Diagram (SDI high).

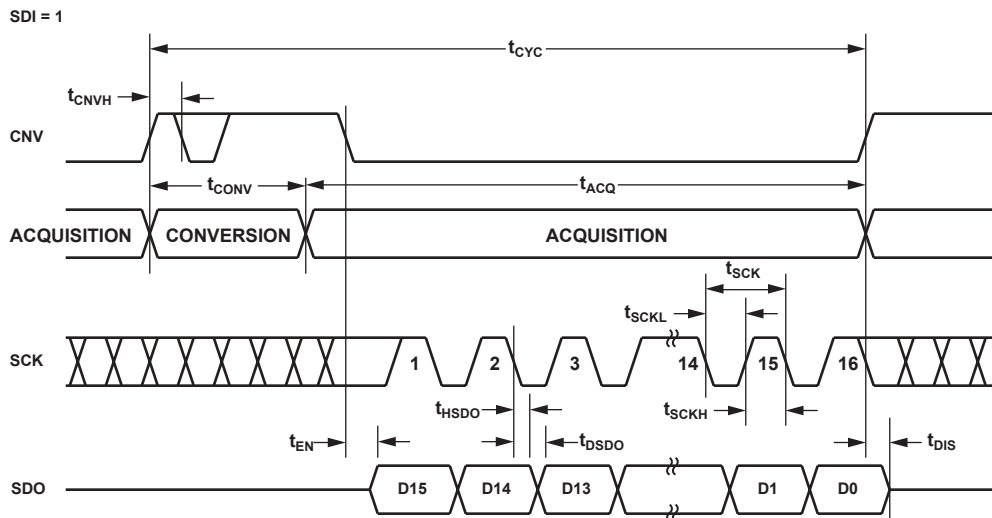

Figure 6. \overline{CS} mode 3 wires without busy indicator Serial Interface Timing (SDI high).

AD7688

$\overline{\text{CS}}$ MODE 3 wires with Busy indicator

This mode is usually used when a single AD7688 is connected to an SPI compatible digital host having an interrupt input. The connection diagram is shown in figure 7 and the corresponding timing is given in figure 8. With SDI tied to OVDD, a rising edge on CNV initiates a conversion, selects the $\overline{\text{CS}}$ mode and forces SDO in high impedance. SDO is maintained in high impedance until the completion of the conversion whatever the state of CNV is. Prior to the minimum conversion time, CNV could be used to select other SPI devices such as analog multiplexers but CNV must be returned low before the minimum conversion time and held low until the maximum conversion time to guarantee the generation of the busy signal indicator. When the conversion is complete, SDO goes from high impedance to low. With a pull-up on SDO line, this transition can be used as an interrupt signal to trigger the data reading controlled by the digital

host. The AD7688 also enters in acquisition phase and in reduced power mode. The data bits are then clocked out, MSB first, by subsequent SCK driving edges. The SCK driving edge, either falling or rising should be selected using a programming sequence. The data is valid on both SCK edges. Although the opposite edge of the rising edge can be used to capture the data, a digital host with acceptable hold time using also the SCK driving edge will allow a faster reading rate. After the optional 17th SCK driving edge or when CNV goes high whichever is the earliest, SDO returns to high impedance.

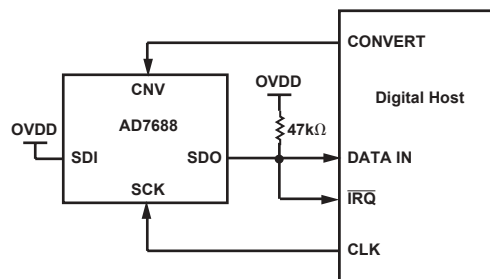

Figure 7. $\overline{\text{CS}}$ mode 3 wires with busy indicator Connection Diagram (SDI high).

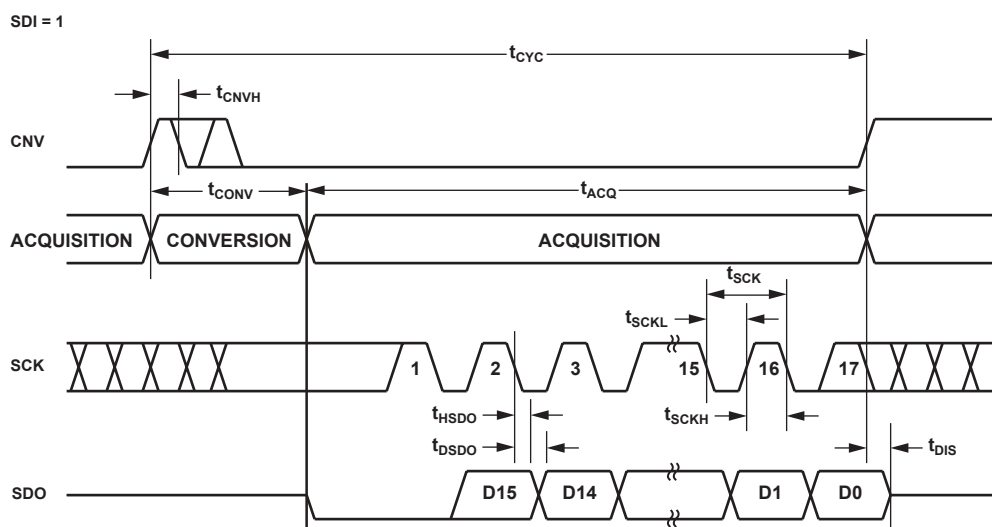

Figure 8. $\overline{\text{CS}}$ mode 3 wires with busy indicator Serial Interface Timing (SDI high).

\overline{CS} MODE 4 wires without Busy indicator

This mode is usually used when multiple AD7688's are connected to an SPI compatible digital host. A connection diagram example using two AD7688's is shown in figure 9 and the corresponding timing is given in figure 10.

With SDI high, a rising edge on CNV initiates a conversion, selects the \overline{CS} mode and forces SDO in high impedance. In this mode, CNV is held high during the conversion phase and the subsequent data reading. SDI must be high before the minimum conversion time and held high until the maximum conversion time to avoid the generation of the busy signal indicator. When the conversion is complete, the AD7688 enters in acquisition phase and in reduced power mode. Each ADC result can be read by bringing low its SDI input which outputs the MSB on

SDO. The remaining data bits are then clocked by subsequent SCK driving edges. The SCK driving edge, either falling or rising should be selected using a programming sequence. The data is valid on both SCK edges. Although the opposite edge of the driving edge can be used to capture the data, a digital host with acceptable hold time using also the SCK driving edge will allow a faster reading rate and more AD7688s on a single SPI port. After the 16th SCK driving edge or when SDI goes high which ever is the earliest, SDO returns to high impedance and another AD7688 can be read.

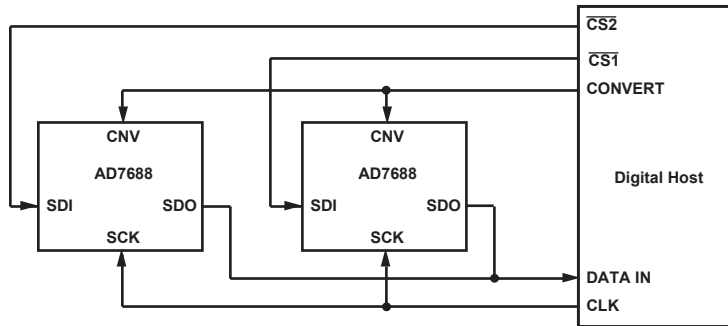

Figure 9. \overline{CS} mode 4 wires without busy indicator Connection Diagram.

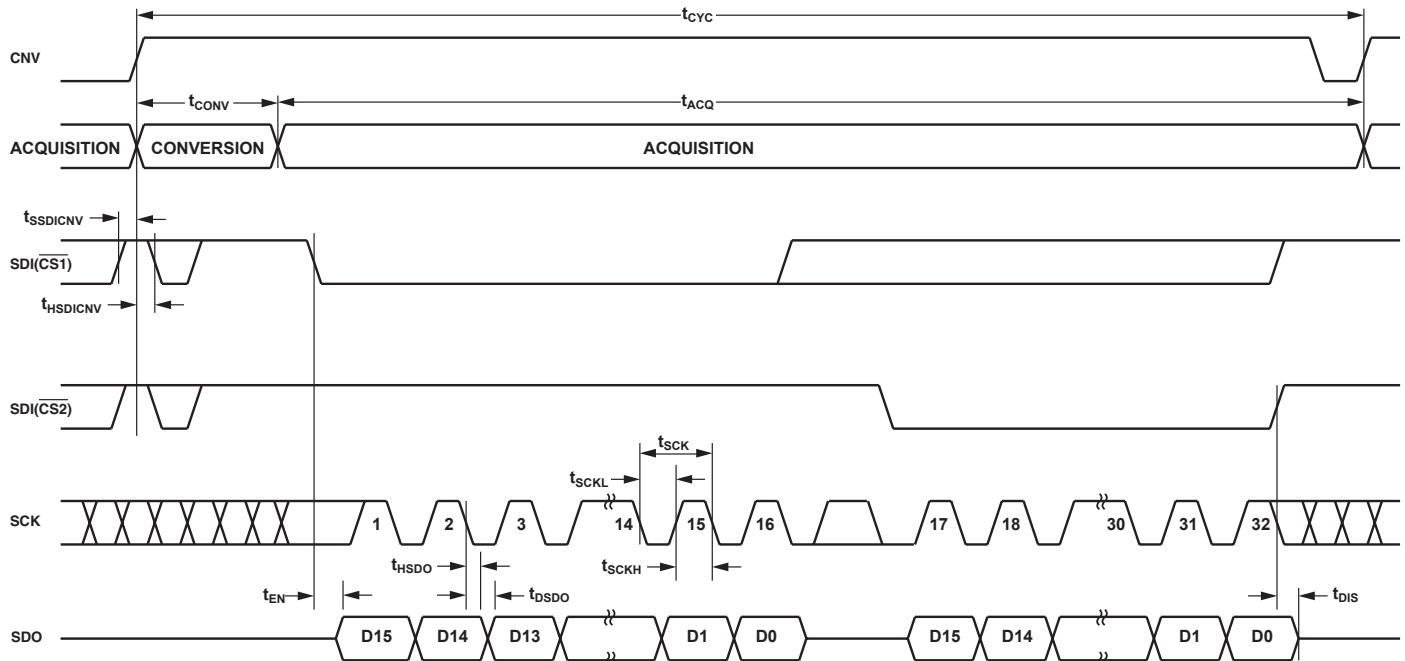

Figure 10. \overline{CS} mode 4 wires without busy indicator Serial Interface Timing.

AD7688

\overline{CS} MODE 4 wires with Busy indicator

This mode is usually used when a single AD7688 is connected to an SPI compatible digital host having an interrupt input and it is desired to keep CNV, used to sample the analog input, independent of the signal used to select the data reading. This requirement is particularly important in applications where low jitter on CNV is desired.

The connection diagram is shown in figure 11 and the corresponding timing is given in figure 12. With SDI high, a rising edge on CNV initiates a conversion, selects the \overline{CS} mode and forces SDO in high impedance. In this mode, CNV is held high during the conversion phase and the subsequent data reading. Prior to the minimum conversion time, SDI could be used to select other SPI devices such as analog multiplexers but SDI must be returned low before the minimum conversion time and held low until the maximum conversion time to guarantee the generation of the busy signal indicator.

When the conversion is complete, SDO goes from high impedance to low. With a pull-up on SDO line, this transition can be used as an interrupt signal to trigger the data reading controlled by the digital host. The AD7688 also enters in acquisition phase and in reduced power mode. The data bits are then clocked out, MSB first, by subsequent SCK driving edges. The SCK driving edge, either falling or rising should be selected using a programming sequence. The data is valid on both SCK edges. Although the opposite edge of the driving edge can be used to capture the data, a digital host with acceptable hold time using also the SCK driving edge will allow a faster reading rate. After the optional 17th SCK driving edge or SDI goes high whichever is the earliest, the SDO returns to high impedance.

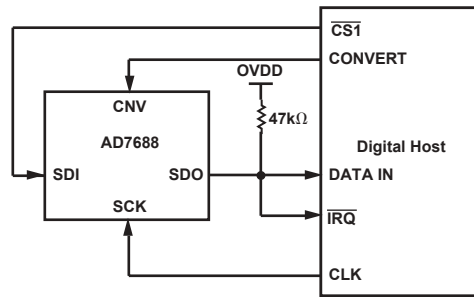

Figure 11. \overline{CS} mode 4 wires with busy indicator Connection Diagram .

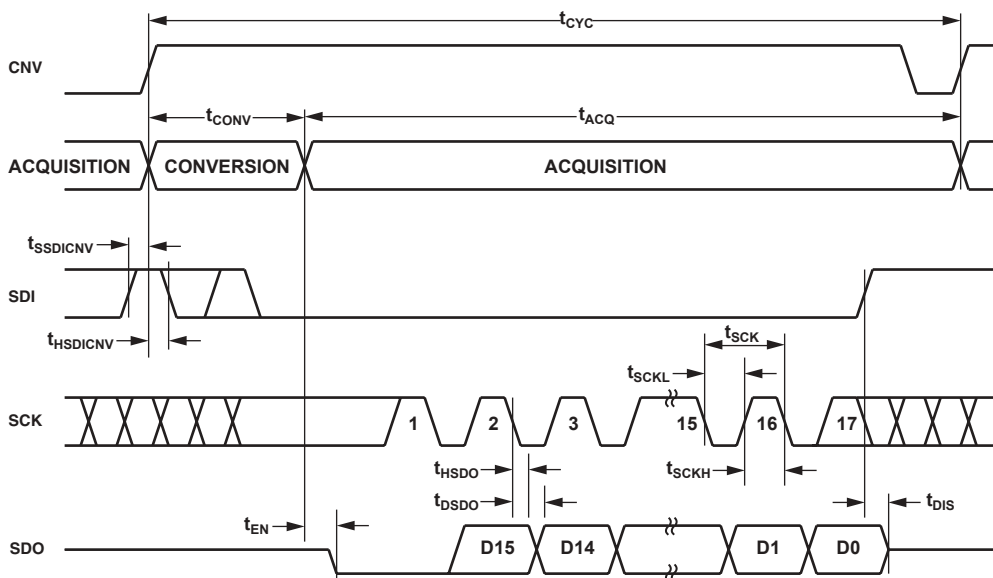

Figure 12. \overline{CS} mode 4 wires with busy indicator Serial Interface Timing.

Chain MODE without Busy indicator

This mode can be used to “daisy-chain” multiple AD7688’s on a single 3 wire serial interface. This feature is useful for reducing component count and wiring connections when desired as, for instance, in isolated multiconverter application or for systems with a limited capacity for interfacing to a large number of converters. A connection diagram example using two AD7688’s is shown in figure 13 and the corresponding timing is given in figure 14.

With SDI tied to ground, SDO is low when CNV is low. With SCK low, a rising edge on CNV initiates a conversion, selects the Chain mode and disables the busy indicator. In this mode, CNV is held high during the conversion phase and the subsequent data reading. When the conversion is complete, the MSB is output on SDO, the

AD7688 enters in acquisition phase and in reduced power mode. The remaining data bits stored in the internal output data shift register are then clocked by subsequent SCK driving edges. The SCK driving edge, either falling or rising should be selected using a programming sequence. This internal output data shift register is also filled in on each SCK driving edge by the SDI data. By connecting SDO output of an “upstream” device to the SDI input of a “downstream” device, after the 16th SCK driving edge, the MSB of the “upstream” device is output on SDO and, consequently, the result of all devices in the chain is output serially on the SDO output of the last “downstream” device. The data is valid on both SCK edges. Although the opposite edge of the driving edge can be used to capture the data, a digital host with acceptable hold time using also the SCK driving edge will allow a faster reading rate and more AD7688s in the chain. Because the ADCs are read during the acquisition phase, the maximum conversion is reduced depending on the length of the chain. For instance, with a 5ns digital host set-up time and 5V interface, up to four AD7688’s running at a conversion rate of 400 kSPS in warp mode can be “daisy-chain” to a single 3 wire port.

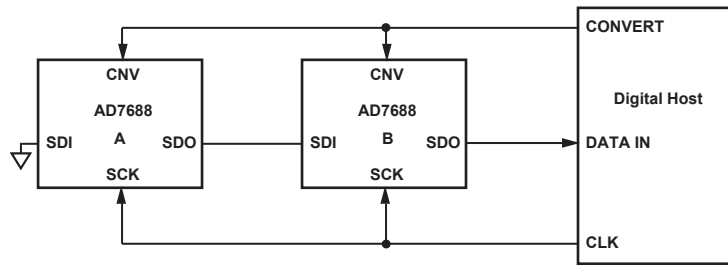

Figure 13. Chain mode without busy indicator Connection Diagram .

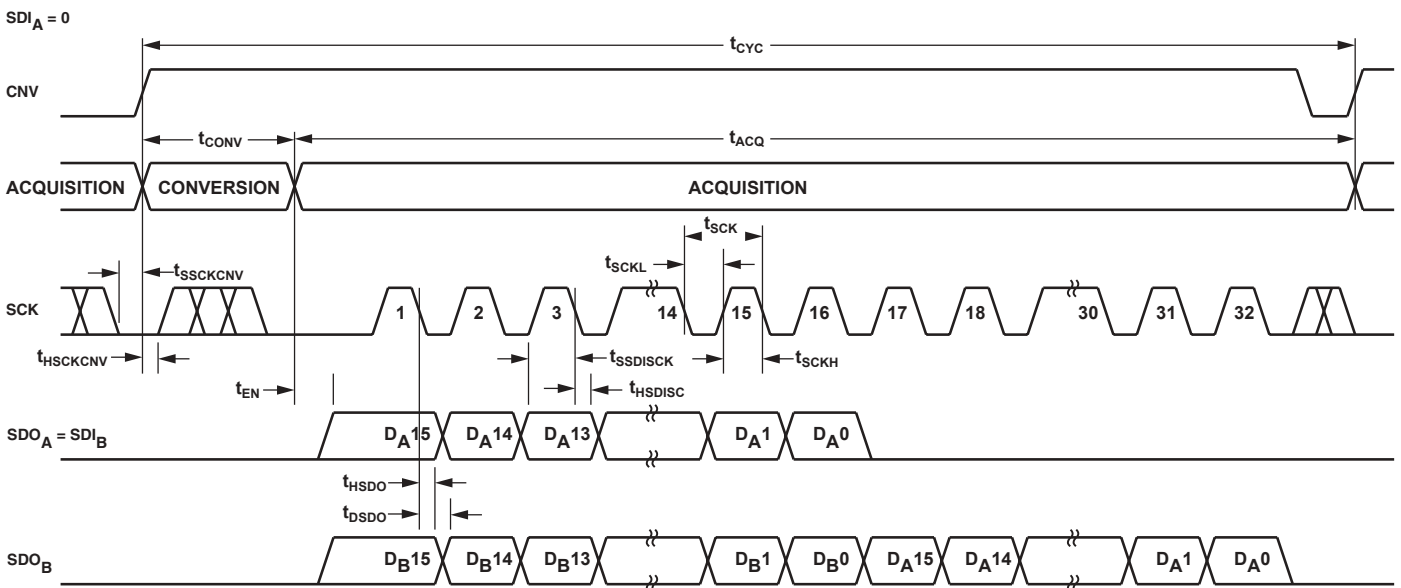

Figure 14. Chain mode without busy indicator Serial Interface Timing.

AD7688

Chain MODE with Busy indicator

This mode can also be used to “daisy-chain” multiple AD7688’s on a single 3 wire serial interface while providing a busy indicator.

A connection diagram example using three AD7688’s is shown in figure 15 and the corresponding timing is given in figure 16.

With SDI and CNV tied together, SDO is low when CNV is low. With SCK high, a rising edge on CNV/SDI initiates a conversion, selects the Chain mode and enables the busy indicator feature. In this mode, CNV is held high during the conversion phase and the subsequent data reading. When the conversion is complete and SDI is high, SDO goes high, this transition on SDO can be used as an interrupt signal to trigger the data reading controlled by the digital host. The AD7688 also enters in acquisition

phase and in reduced power mode. The data bits stored in the internal output data shift register are then clocked out, MSB first, by subsequent SCK driving edges. The SCK driving edge, either falling or rising should be selected using a programming sequence. This internal output data shift register is also filled by the SDI data on each SCK driving edge except the first one. By connecting SDO output of an “upstream” device to the SDI input of a “downstream” device, after the 17th SCK driving edge, the MSB of the “upstream” device is output on SDO and, consequently, the result of all devices in the chain is output serially on the SDO output of the last “downstream” device. Similarly, the busy indicator propagates through the chain such that SDO goes high only when all upstream devices conversions are complete. Although the opposite edge of the driving edge can be used to capture the data, a digital host with acceptable hold time using also the SCK driving edge will allow a faster reading rate and more AD7688s in the chain. For instance, with a 5ns digital host set-up time and a 5V interface, up to four AD7688’s running at a conversion rate of 400 kSPS in warp mode can be “daisy-chain” to a single 3 wire port.

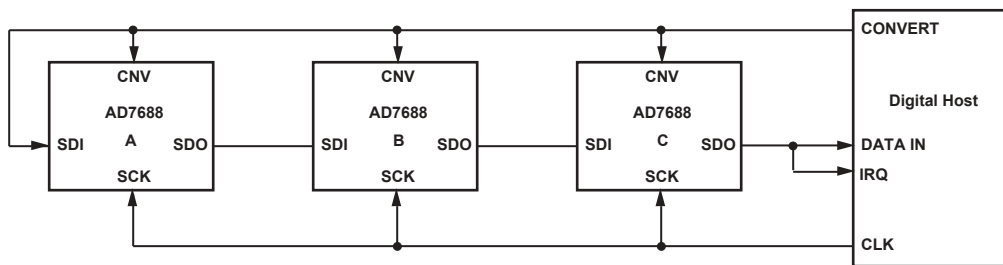

Figure 15. Chain mode with busy indicator Connection Diagram .

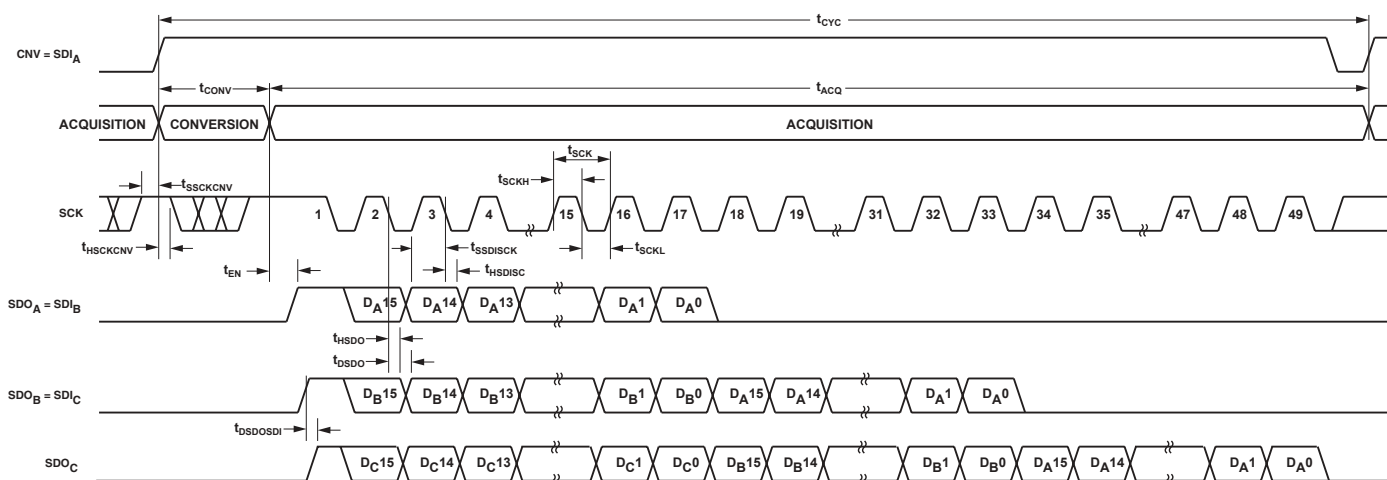

Figure 16. Chain mode with busy indicator Serial Interface Timing.

Programming Configuration

The AD7688 offers the following features which can be selected by the user:

- The modes of operation Warp, Normal or Impulse.
- An internal input low pass filter which limits the bandwidth of the sample-and-hold to reduce noise and alias effect can be enabled.
- The driving edge used to output the data on SDO can be either the rising or the falling edge.
- For interface modes generating the busy indicator, this transition can be synchronized to SCK.
- For ease of use, the configuration can be reset by a single command.
- The configuration can be also read back to confirm the desired operation.

The programming configuration is modified only if less than 16 rising edges are applied on SCK input when the part is selected after the end of conversion. The configuration is actually updated when the part is deselected again. The number of SCK rising edges allows the feature selection according to the table I. The settings are undefined at power-up, therefore a “reset to default settings” programming of the AD7688 has to be done after power-up.

The AD7688 is selected and the SCK rising edges are counted:

- In \overline{CS} mode, when CNV is low and SDI is high (figure 17), or when SDI is low and CNV is high (figure 19). If CNV and SDI are both low, the previous SCK rising edges which occurred during the current part selection are ignored and the configuration is not changed when the part is deselected.
- In Chain mode, when CNV is high (figure 18).

The AD7688 is deselected and the configuration is updated:

- In \overline{CS} mode, when CNV goes high while SDI is high (figure 17), or when SDI goes high while CNV is high (figure 19).
- In Chain mode, when CNV goes low (figure 18).

In \overline{CS} mode using CNV to select the part (figure 17) or in Chain mode (figure 18), only one single change of the configuration can be done per conversion. However, a “Reset to default settings” command (3 or 8 SCK pulses) changes the configuration to a factory predefined configuration (warp mode, High bandwidth, asynchronous busy indicator and falling SCK driving edge). SPI compatible digital hosts offer the possibility to send 8 SCK pulses by software. A truncated valid ADC result is still available on the SDO output.

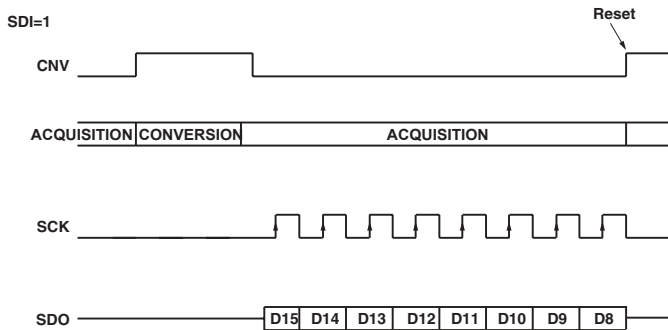

Figure 17. Example of programming configuration using CNV in \overline{CS} mode.

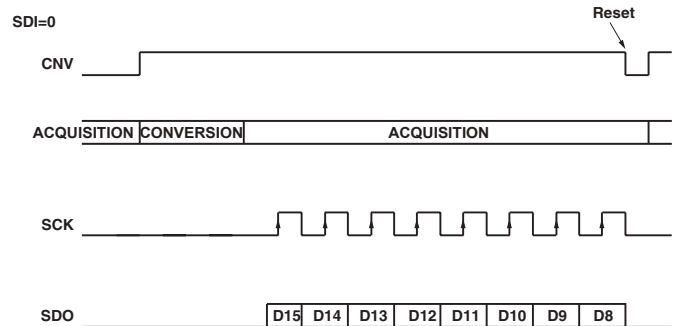

Figure 18. Example of programming configuration using SDI in Chain mode.

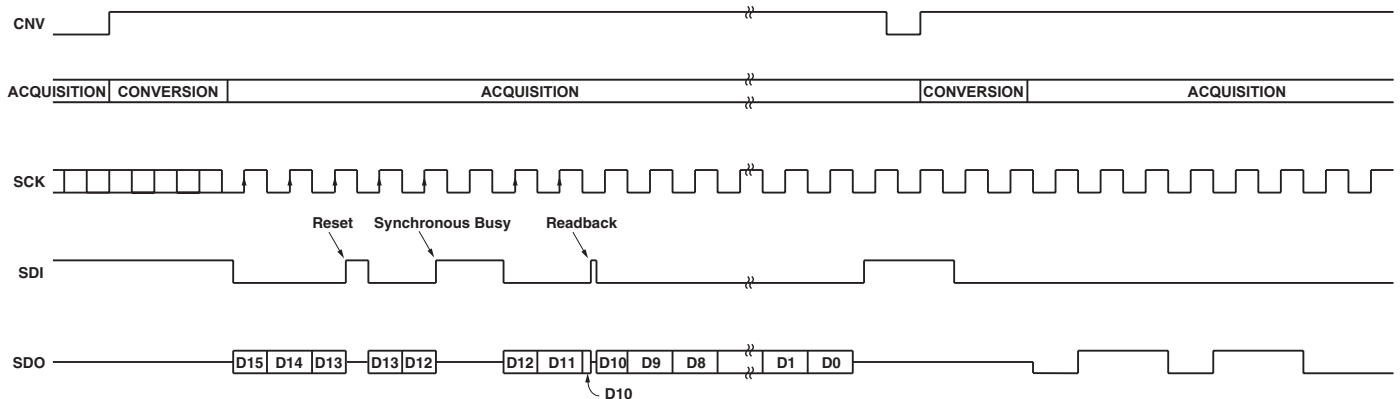

Figure 19. Example of programming configuration using SDI in \overline{CS} mode followed by a configuration readback.

AD7688

In \overline{CS} mode, using SDI to select the part, a complete new configuration could be selected during a single conversion as shown in figure 19. In this case, the selected feature depends on the total number of SCK rising edges seen since the end of conversion. The data on the SDO output is still the valid ADC result and the complete 16 bits result can be read. In the example shown figure 19, the selected configuration is high bandwidth, synchronous busy indicator, falling SCK driving edge, warp mode and the configuration will be readback after the subsequent conversion.

When the mode of operation is changed to warp mode, the next conversion result should be ignored.

In \overline{CS} mode, using SDI to select the part or in Chain mode, when the mode of operation is changed to normal mode, the next conversion should be initiated after a t_{ACQ} delay to provide a valid result otherwise the next conversion result should be ignored for any change to normal mode.

When the mode of operation is changed to impulse mode, the next conversion can be initiated immediately and provides a valid result.

When the readback command is selected, the configuration will be output on the SDO pin in place of the ADC result during the data read of the following conversion as shown in figure 19.

Table I. Programming Configuration

Number of SCK rising edges	Program Feature	Value	Default Settings at Reset	Readback
0	No effect			
1	No effect			1
2	No effect			1
3	Reset to Default settings			0
4	Toggle Bandwidth	High Bandwidth = 1, Low Bandwidth = 0	High Bandwidth	0 or 1
5	Toggle Busy Indicator synchronisation	Synchronous = 1, Asynchronous = 0	Asynchronous	0 or 1
6	Toggle SCK Driving edge synchronisation	Rising = 1, Falling = 0	Falling edge	0 or 1
7	Readback content			0
8	Reset to Default settings			0
9	Set Impulse	Impulse = 1, Warp or Normal = 0	0	0 or 1
10	No effect			0
11	Set Normal	Normal = 1, Impulse or Warp = 0	0	0 or 1
12	No effect			0
13	Set Warp	Warp = 1, Impulse or Normal = 0	Warp	0 or 1
14	No effect			0
15	No effect			1
>15	No effect			1

OUTLINE DIMENSIONS

Dimensions shown in inches and (mm).

10-Lead μ SOIC
(RM-10)

