

FEATURES

Programmable Filtering:

Any Characteristic up to 108 Tap FIR and/or IIR
Polynomial Signal Conditioning up to 8th Order
Programmable Decimation and Output Word Rate

Flexible Programming Modes:

Boot from DSP or External EPROM
Parallel/Serial Interface
Internal Default Filter for Evaluation
14.4 MHz Max Master Clock Frequency
0 V to +4 V (Single-Ended) or ± 2 V (Differential) Input Range

Power Supplies: AV_{DD} , DV_{DD} : 5 V $\pm 5\%$

On-Chip 2.5 V Voltage Reference

44-Lead MQFP Package

TYPICAL APPLICATIONS

Radar
Sonar
Auxiliary Car Functions
Medical Communications

FUNCTIONAL BLOCK DIAGRAM

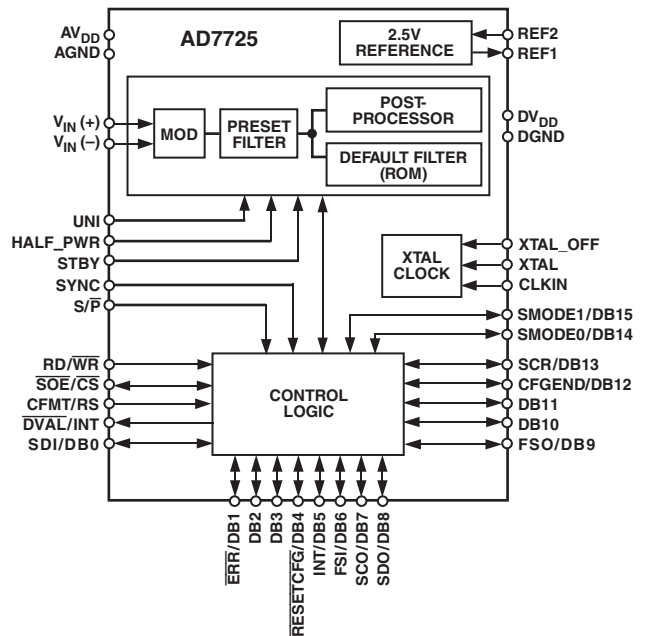

GENERAL DESCRIPTION

The AD7725 is a complete 16-bit, sigma-delta analog-to-digital converter with on-chip, user-programmable signal conditioning. The output of the modulator is processed by three cascaded finite impulse response (FIR) filters, followed by a fully user-programmable postprocessor. The postprocessor provides processing power of up to 130 million accumulates (MAC) per second. The user has complete control over the filter response, the filter coefficients, and the decimation ratio.

The postprocessor permits the signal conditioning characteristics to be programmed through a parallel or serial interface. It is programmed by loading a user-defined filter in the form of a configuration file. This filter can be loaded from a DSP or an external serial EPROM. It is generated using a digital filter design package called Filter Wizard, which is available from the AD7725 section on the Analog Devices website. Filter Wiz-

ard allows the user to design different filter types and generates the appropriate configuration file to be downloaded to the postprocessor. The AD7725 also has an internal default filter for evaluation purposes.

It provides 16-bit performance for input bandwidths up to 350 kHz with an output word rate of 900 kHz maximum. The input sample rate is set either by the crystal oscillator or an external clock.

This part has an accurate on-chip 2.5 V reference for the modulator. A reference input/output function is provided to allow either the internal reference or an external system reference to be used as the reference source for the modulator.

The device is available in a 44-lead MQFP package and is specified over a -40°C to $+85^{\circ}\text{C}$ temperature range.

REV. 0

Information furnished by Analog Devices is believed to be accurate and reliable. However, no responsibility is assumed by Analog Devices for its use, nor for any infringements of patents or other rights of third parties that may result from its use. No license is granted by implication or otherwise under any patent or patent rights of Analog Devices. Trademarks and registered trademarks are the property of their respective companies.

AD7725—SPECIFICATIONS¹ ($AV_{DD} = 5\text{ V} \pm 5\%$, $AGND = AGND1 = AGND2 = DGND = 0\text{ V}$, $F_{CLKIN}^2 = 9.6\text{ MHz}$, $REF2 = 2.5\text{ V}$, $T_A = T_{MIN}$ to T_{MAX} , unless otherwise noted.)

Parameter	Test Conditions/Comments	B Version			Unit
		Min	Typ	Max	
DYNAMIC SPECIFICATIONS					
Bipolar Mode Signal to Noise ³	When tested with the FIR filter in Figure 1. HALF_PWR = Logic High Measurement Bandwidth = $0.5 \times F_O^4$ 2.5 V Reference 3 V Reference	77 79	83 85		dB dB
Total Harmonic Distortion ^{3, 5} Spurious Free Dynamic Range ^{3, 5}			-94 -98	-86 -89	dB dB
Unipolar Mode Signal to Noise ³ Total Harmonic Distortion ^{3, 5}	Measurement Bandwidth = $0.5 \times F_O^4$		83 -94		dB dB
ANALOG INPUTS					
Full-Scale Input Span Bipolar Mode Unipolar Mode	$V_{IN(+)} - V_{IN(-)}$ Differential or Single-Ended Input Single-Ended Input	0		$\pm 4/5 \times V_{REF2}$ $8/5 \times V_{REF2}$	V V
Absolute Input Voltage Input Sampling Capacitance Input Sampling Rate, F_{CLKIN}	$V_{IN(+)}$ and/or $V_{IN(-)}$	AGND	2	AV_{DD} 14.4 ⁶	V pF MHz
CLOCK					
CLKIN Duty Ratio		45		55	%
REFERENCE					
REF1 Output Resistance Reference Buffer Offset Voltage	Offset between REF1 and REF2		3.5	± 3	k Ω mV
Using Internal Reference REF2 Output Voltage REF2 Output Voltage Drift		2.39	2.54 60	2.69	V ppm/ $^{\circ}\text{C}$
Using External Reference REF2 Input Impedance REF2 External Voltage Input ⁷	REF1 = AGND		8 2.5		k Ω V
STATIC PERFORMANCE					
Resolution Differential Nonlinearity (DNL) ³ Integral Nonlinearity (INL) ³ DC CMRR Offset Error Gain Error ^{3, 9}	Guaranteed Monotonic	16	± 0.5 ± 2 80	$\pm 1^8$	Bits LSB LSB dB mV %FSR
LOGIC INPUTS (Excluding CLKIN)					
V_{INH} , Input High Voltage V_{INL} , Input Low Voltage		2.0		0.8	V V
CLOCK INPUT (CLKIN)					
V_{INH} , Input High Voltage V_{INL} , Input Low Voltage		$0.7 \times DV_{DD}$		$0.3 \times DV_{DD}$	V V

Parameter	Test Conditions/Comments	B Version			Unit	
		Min	Typ	Max		
ALL LOGIC INPUTS						
I_{IN} , Input Current	$V_{IN} = 0 \text{ V to } DV_{DD}$			± 10	μA	
C_{IN} , Input Capacitance			10		pF	
LOGIC OUTPUTS						
V_{OH} , Output High Voltage	$ I_{OUT} = 200 \mu\text{A}$ $ I_{OUT} = 1.6 \text{ mA}$	4.0			V	
V_{OL} , Output Low Voltage				0.4	V	
POWER SUPPLIES ¹⁰						
AV_{DD}	HALF_PWR = Logic High ¹²	4.75		5.25	V	
AI_{DD} ¹¹				28	33	mA
DV_{DD}	With the Filter in Figure 1. Standby Mode	4.75		5.25	V	
DI_{DD} ¹³				84	90	mA
Power Consumption ¹⁴					30	mW

NOTES

¹Operating Temperature Range is as follows: B Version: -40°C to $+85^{\circ}\text{C}$.

² F_{CLKIN} is the CLKIN frequency.

³See Terminology section.

⁴ F_O = Output Data Rate.

⁵When using the internal reference, THD and SFDR specifications apply only to input signals above 10 kHz with a 10 μF decoupling capacitor between REF2 and AGND2. At frequencies below 10 kHz, THD degrades to -80 dB and SFDR degrades to -83 dB .

⁶See Figures 23 and 24 for information regarding the number of filter taps allowed and the current consumption as the CLKIN frequency is varied.

⁷The AD7725 can operate with an external reference input in the range of 1.2 V to 3.15 V.

⁸Guaranteed by the design.

⁹Gain Error excludes reference error.

¹⁰All I_{DD} tests are done with the digital inputs equal to 0 V or DV_{DD} .

¹¹Analog current does not vary as the CLKIN frequency and the number of filter taps used in the postprocessor is varied.

¹²If HALF_PWR is logic low, AI_{DD} will typically double.

¹³Digital current varies as the CLKIN frequency and the number of filter taps used in the postprocessor is varied. See Figures 23 and 24.

¹⁴Digital inputs static and equal to 0 or DV_{DD} .

Specifications subject to change without notice.

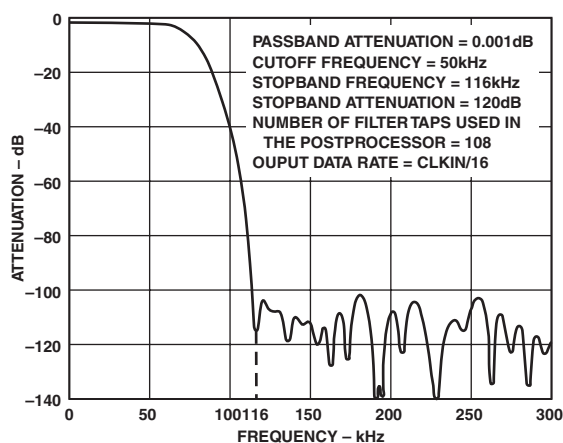

Figure 1. Digital Filter Characteristics Used for Specifications

AD7725

Preset Filter, Default Filter, and Postprocessor Characteristics^{1, 2}

Parameter	Test Conditions/Comments	Min	Typ	Max	Unit
DIGITAL FILTER RESPONSE PRESET FIR Data Output Rate Stop-Band Attenuation Low-Pass Corner Frequency Group Delay ³ Settling Time ³		70	$F_{CLKIN}/16$ $133/(2 \times F_{CLKIN})$ $133/F_{CLKIN}$	$F_{CLKIN}/8$	Hz dB Hz s s
DEFAULT FILTER Number of Taps Frequency Response 0 kHz to $F_{CLKIN}/546.08$ $F_{CLKIN}/195.04$ $F_{CLKIN}/184.08$ $F_{CLKIN}/133.2$ to $F_{CLKIN}/2$ Group Delay ³ Settling Time ³ Output Data Rate, F_O	Internal FIR Filter Stored in ROM	-3 -6	$2141/(2 \times F_{CLKIN})$ $2141/F_{CLKIN}$ $F_{CLKIN}/32$	106 ± 0.001 -120	dB dB dB s s Hz
POSTPROCESSOR CHARACTERISTICS					
Input Data Rate Coefficient Precision ⁴ Arithmetic Precision No. of Taps Permitted Decimation Factor No. of Decimation Stages Output Data Rate		2 1 $F_{CLKIN}/4096$	24 30	$F_{CLKIN}/8$ 108 256 5 $F_{CLKIN}/16$	Hz Bits Bits Hz

NOTES

¹These characteristics are fixed by the design.

² F_{CLKIN} is the CLKIN frequency.

³See Terminology.

⁴See the Configuration File Format section for more information.

TIMING SPECIFICATIONS^{1, 2} ($V_{DD} = 5 V \pm 5\%$; $DV_{DD} = 5 V \pm 5\%$; $AGND = DGND = 0 V$, $REF2 = 2.5 V$, unless otherwise noted.)

AD7725

Parameter	Symbol	Min	Typ	Max	Unit
CLKIN Frequency	f_{CLKIN}	1		14.4	MHz
CLKIN Period ($t_{CLK} = 1/f_{CLKIN}$)	t_1	0.07		1	μs
CLKIN Low Pulsewidth	t_2	$0.45 \times t_1$		$0.55 \times t_1$	
CLKIN High Pulsewidth	t_3	$0.45 \times t_1$		$0.55 \times t_1$	
CLKIN Rise Time	t_4	5			ns
CLKIN Fall Time	t_5	5			ns
CLKIN to SCO Delay	t_6		35	50	ns
SCO Period: SCR = 0	t_7		1		t_{CLK}
SCR = 1	t_7		2		t_{CLK}
SERIAL INTERFACE (DSP MODE ONLY)					
FSI Setup Time before SCO Transition	t_8	30			ns
FSI Hold Time after SCO Transition	t_9	0			ns
SDI Setup Time	t_{10}	30			ns
SDI Hold Time	t_{11}	0			ns
SERIAL INTERFACE (DSP AND BFR MODES)					
SCO Transition to FSO High Delay	t_{12}			20	ns
SCO Transition to FSO Low Delay	t_{13}			20	ns
SDO Setup before SCO Transition	t_{14}			10	ns
SDO Hold after SCO Transition	t_{15}	0			ns
SERIAL INTERFACE (EPROM MODE)					
SCO High Time	t_{16}			8	t_{CLK}
SCO Low Time	t_{17}			8	t_{CLK}
\overline{SOE} Low to First SCO Rising Edge	t_{18}			20	t_{CLK}
Data Setup before SCO Rising Edge	t_{19}		22		ns
PARALLEL INTERFACE					
DATA WRITE					
RS Low to \overline{CS} Low	t_{20}	15			ns
\overline{WR} Setup before \overline{CS} Low	t_{21}	15			ns
RS Hold after \overline{CS} Rising Edge	t_{22}	0			ns
\overline{CS} Pulsewidth	t_{23}	50			ns
\overline{WR} Hold after \overline{CS} Rising Edge	t_{24}	0			ns
Data Setup Time	t_{25}	10			ns
Data Hold Time	t_{26}	5			ns
DATA READ					
RS Low to \overline{CS} Low	t_{27}	15			ns
RD Setup before \overline{CS} Low	t_{28}	15			ns
RS Hold after \overline{CS} Rising Edge	t_{29}	0			ns
RD Hold after \overline{CS} Rising Edge	t_{30}	0			ns
Data Valid after \overline{CS} Falling Edge ³	t_{31}			30	ns
Data Hold after \overline{CS} Rising Edge	t_{32}	10			ns
STATUS READ/INSTRUCTION WRITE					
\overline{CS} Duty Cycle	t_{33}	1			t_{CLK}
Interrupt Clear after \overline{CS} Low	t_{34}			15	ns
RD Setup to \overline{CS} Low	t_{35}	15			ns
RD Hold after \overline{CS} Rising Edge	t_{36}			0	ns
Read Data Access Time ³	t_{37}			30	ns
Read Data Hold after \overline{CS} Rising Edge	t_{38}	10			ns
Write Data Setup before \overline{CS} Rising Edge	t_{39}	10			ns
Write Data Hold after \overline{CS} Rising Edge	t_{40}	5			ns

NOTES

¹Guaranteed by design.

²Sample tested at 25°C to ensure compliance. All input signals are specified with $t_r = t_f = 5 ns$ (10% to 90% of DV_{DD}) and timed from a voltage level of 1.6 V.

³Measured with the load circuit in Figure 2 and defined as the time required for the output to cross 0.8 V and 2.4 V.

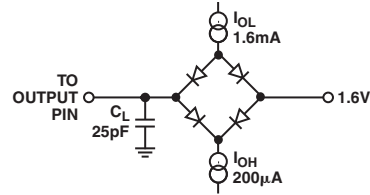

Figure 2. Load Circuit for Digital Output Timing Specifications

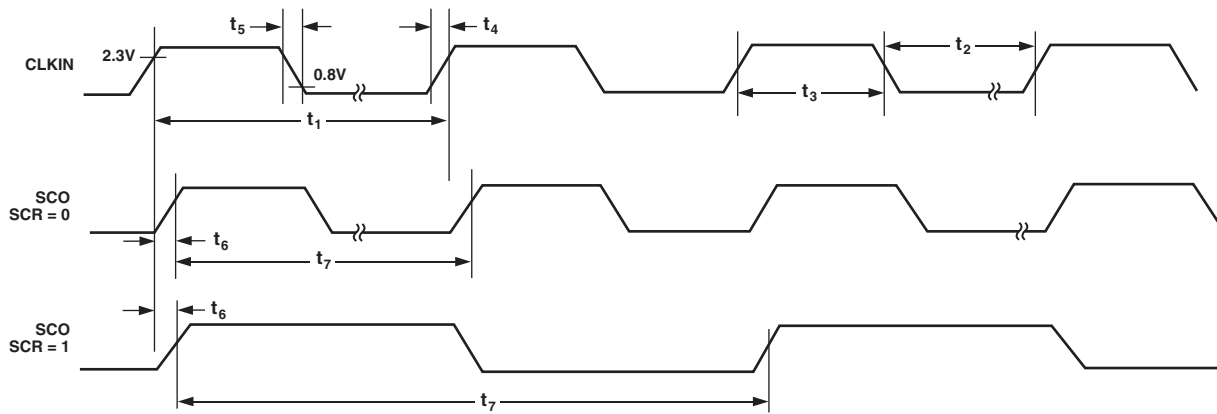

Figure 3. CLKIN to SCO Relationship

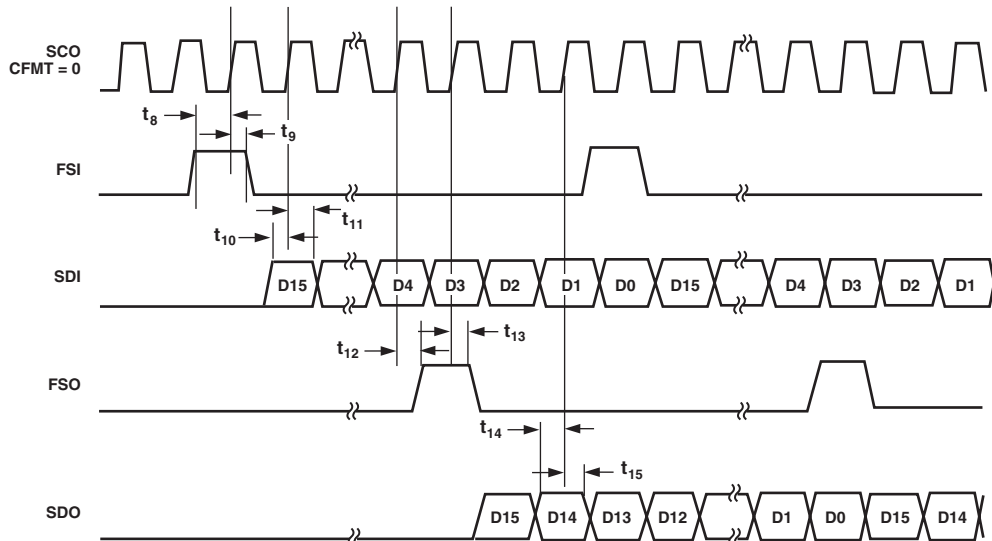

Figure 4. Serial Mode (DSP Mode and Boot from ROM (BFR) Mode). In BFR Mode, FSI and SDI Are Not Used.

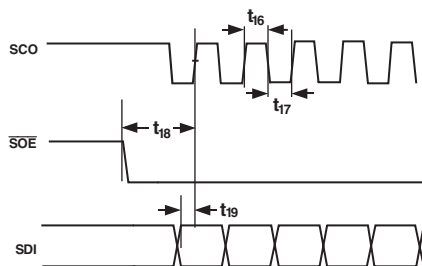

Figure 5. Serial Mode (EPROM Mode)

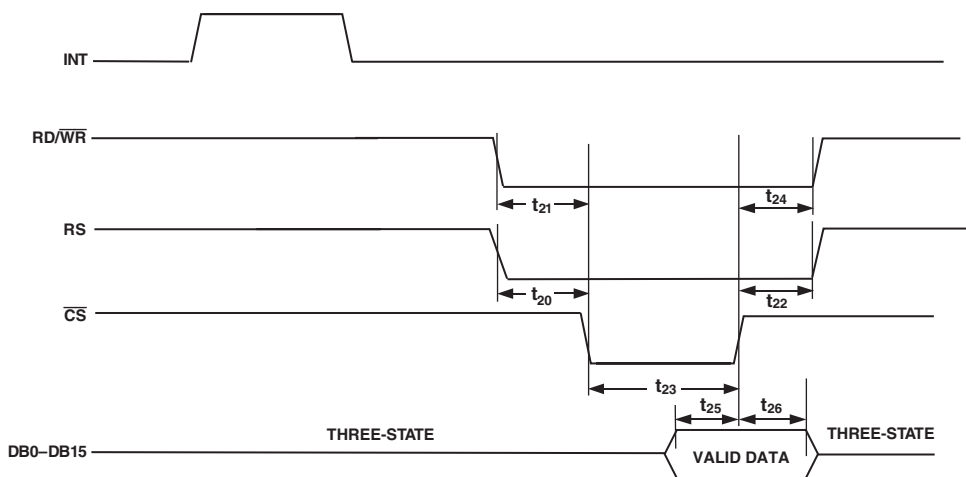

Figure 6. Parallel Mode (Writing Data to the AD7725)

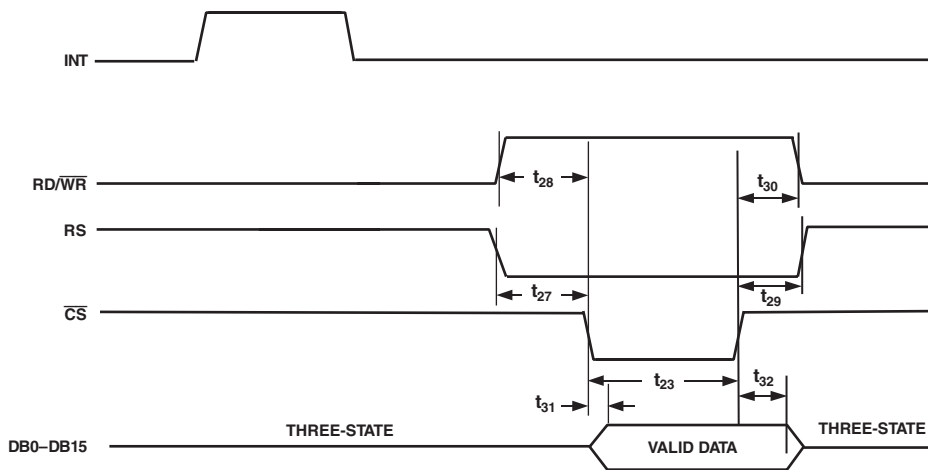

Figure 7. Parallel Mode (Reading Data to the AD7725)

AD7725

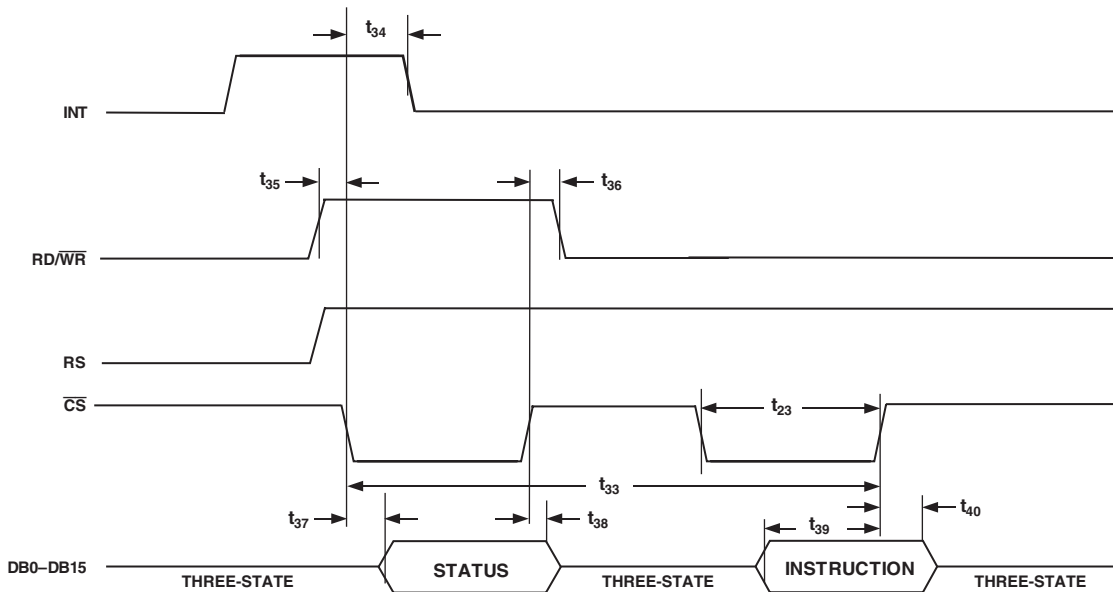

Figure 8. Parallel Mode (Reading the Status Register and Writing Instructions)

ABSOLUTE MAXIMUM RATINGS¹

($T_A = 25^\circ\text{C}$, unless otherwise noted.)

DV _{DD} to DGND	−0.3 V to +7 V
AV _{DD} to AGND	−0.3 V to +7 V
AV _{DD} , AV _{DD1} to DV _{DD}	−1 V to +1 V
AGND, AGND1 to DGND	−0.3 V to +0.3 V
Digital Inputs to DGND	−0.3 V to DV _{DD} + 0.3 V
Digital Outputs to DGND	−0.3 V to DV _{DD} + 0.3 V
V _{IN} (+), V _{IN} (−) to AGND	−0.3 V to AV _{DD} + 0.3 V
REF1 to AGND	−0.3 V to AV _{DD} + 0.3 V
REF2 to AGND	−0.3 V to AV _{DD} + 0.3 V
REFIN to AGND	−0.3 V to AV _{DD} + 0.3 V
DGND, AGND	±0.3 V
Input Current to Any Pin Except Supplies ²	±10 mA
I _{DD} (A _{IDD} + D _{IDD})	150 mA
Operating Temperature Range	−40°C to +85°C
Storage Temperature Range	−65°C to +150°C
Junction Temperature	150°C
θ_{JA} Thermal Impedance	58° C/W
θ_{JC} Thermal Impedance	20° C/W
Lead Temperature, Soldering	
Vapor Phase (60 sec)	215°C
Infrared (15 sec)	220°C
ESD	2 kV

NOTES

¹Stresses above those listed under Absolute Maximum Ratings may cause permanent damage to the device. This is a stress rating only; functional operation of the device at these or any other conditions above those indicated in the operational section of this specification is not implied. Exposure to absolute maximum rating conditions for extended periods may affect device reliability.

²Transient currents of up to 100 mA will not cause SCR latch-up.

CAUTION

ESD (electrostatic discharge) sensitive device. Electrostatic charges as high as 4000 V readily accumulate on the human body and test equipment and can discharge without detection. Although the AD7725 features proprietary ESD protection circuitry, permanent damage may occur on devices subjected to high energy electrostatic discharges. Therefore, proper ESD precautions are recommended to avoid performance degradation or loss of functionality.

ORDERING GUIDE

Model	Temperature Range	Package Description	Package Option ¹
AD7725BS	−40°C to +85°C	Plastic Quad Flatpack	S-44
EVAL-AD7725CB ²		Evaluation Board	
EVAL-CONTROL BRD2 ³		Controller Board	

¹S = Plastic Quad Flatpack (MQFP)

²This board can be used as a standalone evaluation board or in conjunction with the Evaluation Board Controller for evaluation/demonstration purposes. It is accompanied by software and technical documentation.

³Evaluation Board Controller. This board is a complete unit allowing a PC to control and communicate with all Analog Devices boards ending in the CB designator. To obtain the complete evaluation kit, the following needs to be ordered: EVAL-AD7725CB, EVAL-CONTROL BRD2, and a 12 V ac transformer. The Filter Wizard software can be downloaded from the Analog Devices website.



PIN CONFIGURATION

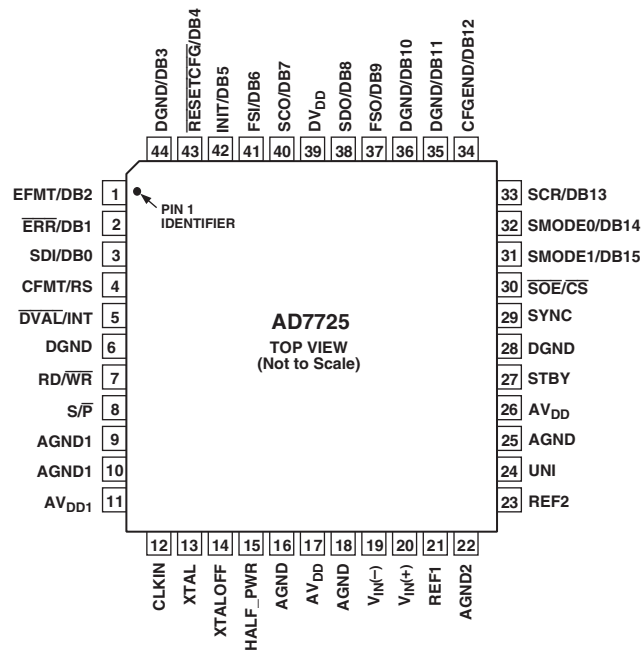

PIN FUNCTION DESCRIPTION

Pin No.	Mnemonic S/P	Description
1	EFMT/DB2	Serial Mode. EFMT–Serial Clock Format, Logic Input. This clock format pin selects the clock edge to be used during configuration. When EFMT is low, Serial Data In is valid on the rising edge of SCO; when EFMT is high, Serial Data In is valid on the falling edge of SCO. During normal operation, this pin is ignored.
2	$\overline{\text{ERR}}/\text{DB1}$	Parallel Mode. DB2–Data Input/Output Bit. Serial Mode. $\overline{\text{ERR}}$ –Configuration Error Flag, Logic Output. If an error occurs during configuration, this output goes low and is reset high by a pulse on the RESETCFG pin.
3	SDI/DB0	Parallel Mode. DB1–Data Input/Output Bit. Serial Mode. SDI–Serial Data Input. Serial data is shifted in to the AD7725 MSB first, in two complement format, synchronous with SCO.
4	CFMT/RS	Parallel Mode. DB0–Data Input/Output Bit (LSB). Serial Mode. CFMT–Serial Clock Format, Logic Input. This clock format pin selects the clock edge to be used during normal operation. When CFMT is low, Serial Data Out is valid on the rising edge of SCO; when CFMT is high, Serial Data Out is valid on the falling edge of SCO. During configuration, this pin is ignored. Parallel Mode. RS–Register Select. RS selects between the data register, used to read conversion data or write configuration data, and the instruction register. When RS is high, the Status Register can be read or an instruction can be written to the AD7725. When RS is low, data such as the configuration file can be written to the ADC while data such as the device ID or a conversion result can be read from the AD7725 (see Table I).

AD7725

Pin No.	Mnemonic S/P	Description
5	$\overline{\text{DVAL}}/\text{INT}$	<p>Serial Mode. $\overline{\text{DVAL}}$–Data Valid Logic Output. This output is low when there are no overflows in the postprocessor and goes high when an overflow occurs in the postprocessor.</p> <p>Parallel Mode. INT–Interrupt Logic Output. INT idles low. A logic high on this output pin indicates that user intervention is required. There are several cases when this may occur: (i) An instruction is completed. Writing an instruction or reading the status register clears the interrupt. (ii) Write data is requested. Writing data clears the interrupt. (iii) Read data is ready. Reading data clears the interrupt. (iv) An error occurs–ID or CRC error in the configuration file format, or an overflow in the postprocessor. Reading the Status Register clears the interrupt. (v) The device completes power on reset. Reading the Status Register clears the interrupt.</p>
6	DGND	Ground Reference for Digital Circuitry
7	$\text{RD}/\overline{\text{WR}}$	<p>Serial Mode. This input is not used in Serial Mode and should be tied to DGND.</p> <p>Parallel Mode. Read/Write Logic Input. This input is used in conjunction with the $\overline{\text{CS}}$ input to read data from or write data to the device. A read cycle is initiated when $\text{RD}/\overline{\text{WR}}$ is high. A write cycle is initiated when $\text{RD}/\overline{\text{WR}}$ is low. To read or write data, $\overline{\text{CS}}$ should be low.</p>
8	$\text{S}/\overline{\text{P}}$	Serial/Parallel Interface Select. When $\text{S}/\overline{\text{P}}$ is tied low, Parallel Mode is selected. Serial Mode is selected when $\text{S}/\overline{\text{P}}$ is tied high. To change the mode, a full power cycle needs to be performed.
9, 10	AGND1	Digital Logic Power Supply Ground for the Analog Modulator
11	AV_{DD1}	Digital Logic Power Supply for the Analog Modulator
12	CLKIN	Clock Input. An external clock source can be applied directly to this pin with XTALOFF tied high. Alternatively, a parallel resonant fundamental frequency crystal, in parallel with a 1 M Ω resistor can be connected between the XTAL pin and the CLKIN pin with XTALOFF tied low. External capacitors are then required from the CLKIN and XTAL pins to ground. Consult the crystal manufacturer’s recommendation for the load capacitors. In both cases, once power is applied to the AD7725, the clock input has to be continual.
13	XTAL	Input to Crystal Oscillator Amplifier. If an external clock is used, XTAL should be tied to AGND1.
14	XTALOFF	Oscillator Enable Input. A logic high disables the crystal oscillator amplifier to allow the use of an external clock source. Set low to enable the crystal oscillator amplifier when using an external crystal between the CLKIN and XTAL pins.
15	HALF_PWR	Logic Input. When this input is low, the typical analog current is 50 mA and a maximum CLKIN frequency of 14.4 MHz applies. When this input is high, the analog current typically halves and a maximum CLKIN frequency of 9.6 MHz applies.
16, 18	AGND	Power Supply Ground for the Analog Modulator
17	AV_{DD}	Power Supply Voltage for the Analog Modulator
19	$\text{V}_{\text{IN}}(-)$	Negative Terminal of the Differential Analog Input
20	$\text{V}_{\text{IN}}(+)$	Positive Terminal of the Differential Analog Input
21	REF1	Reference Output. REF1 is connected to the output of the internal 2.5 V reference through a 3 k Ω resistor and to a reference buffer amplifier that drives the Σ - Δ modulator. When the internal reference is used, a 1 μF capacitor is required between REF1 and AGND to decouple the band gap noise and REF2 should be decoupled to AGND with a 220 nF and a 10 nF capacitor in parallel.
22	AGND2	Power Supply Ground for the Reference Circuitry, REF2, of the Analog Modulator
23	REF2	Reference Input. REF2 connects to the output of an external buffer amplifier used to drive the Σ - Δ modulator. When REF2 is used as an input, REF1 must be connected to AGND to disable the internal buffer amplifier.
24	UNI	Analog Input Range Select Input. The UNI pin selects the analog input range for either bipolar (differential or single-ended input) or unipolar (single-ended input) operation. A logic high input selects unipolar operation and a logic low input selects bipolar operation.
25	AGND	Power Supply Ground for the Analog Modulator
26	AV_{DD}	Power Supply Voltage for the Analog Modulator

Pin No.	Mnemonic S/P	Description
27	STBY	Standby, Logic Input. When STBY is taken high, the device will enter a low power mode. If the device was fully configured before entering this mode, it will not lose its configuration data. When STBY is brought low, the device exits the low power mode. If the device was partly configured before entering the low power mode, it will restart the configuration process in the case of Boot from ROM (BFR) Mode, DSP Mode, and EPROM Mode or, in Parallel Mode, a new configure instruction must be issued to configure the device. If the device was fully configured before entering the low power mode, it will continue to output conversion results in all serial modes; in Parallel Mode, the device will wait for an instruction to begin converting. In STBY Mode, the clock input must be continual.
28	DGND	Ground Reference for Digital Circuitry
29	SYNC	Synchronization Logic Input. When using more than one AD7725 operated from a common master clock, SYNC allows each ADC to simultaneously sample its analog input and update its output register. When SYNC is high, the digital filter sequencer counter is reset to zero and the postprocessor core is reset. Because the digital filter and sequencer are completely reset during this action, SYNC pulses cannot be applied continuously. When SYNC is taken low, normal conversions continue, with valid data resulting after the filter setting time.
30	$\overline{\text{SOE}}/\overline{\text{CS}}$	Serial Mode. $\overline{\text{SOE}}$ –Serial Output Enable. In EPROM Mode, $\overline{\text{SOE}}$ going low enables the external EPROM and is used to reset the EPROM’s address counter. In DSP Mode, $\overline{\text{SOE}}$ is an active high interrupt. It goes high after a power on reset and after a pulse on the $\overline{\text{RESETCFG}}$ pin, indicating the device is ready to be configured. It also goes high following a successful configuration, indicating that the device was configured correctly. $\overline{\text{SOE}}$ is reset low when FSI is detected high by CLKIN. In BFR Mode, $\overline{\text{SOE}}$ pulses high for eight CLKIN cycles at the end of a successful configuration. Parallel Mode. $\overline{\text{CS}}$ –Chip Select Logic Input. This is an active low logic input used in conjunction with the RD/ $\overline{\text{WR}}$ input to read data from or write data to the device. For a Read operation, the falling edge of $\overline{\text{CS}}$ takes the bus out of three-state and either the conversion data or the status register data (depending on the state of the RS input), is placed onto the databus, after the time t_{31} . For a Write operation, the rising edge of $\overline{\text{CS}}$ is used to latch either the configuration data or the instruction (depending on the state of the RS input) into the AD7725. In this case, the data should be set up for a time t_{25} before the $\overline{\text{CS}}$ rising edge.
31	SMODE1/DB15	Serial Mode. SMODE1–Serial Mode Select, Logic Input. This pin selects the serial mode to be used (see Table IV) and thus informs the device where to download configuration data from automatically on power up. To change the value on this pin, a full power cycle needs to be performed. Parallel Mode. DB15–Data Input/Output Bit (MSB).
32	SMODE0/DB14	Serial Mode. SMODE0–Serial Mode Select, Logic Input. This pin selects the serial mode to be used (see Table IV) and thus informs the device where to download configuration data from automatically on power-up. To change the value on this pin, a full power cycle needs to be performed. Parallel Mode. DB14–Data Input/Output Bit.
33	SCR/DB13	Serial Mode. SCR–Serial Clock Rate Select, Logic Input. With SCR set to logic low, the serial clock output frequency, SCO, is equal to the CLKIN frequency. A logic high sets the frequency of SCO to one half the CLKIN frequency. Parallel Mode. DB13–Data Input/Output Bit.
34	CFGEND/DB12	Serial Mode. CFGEND–Configuration End, Logic Output. A logic high on CFGEND indicates that device programming is complete and no programming errors occurred. Parallel Mode. DB12–Data Input/Output Bit.
35	DGND/DB11	Serial Mode. DGND–Digital Ground. Parallel Mode. DB11–Data Input/Output Bit.
36	DGND/DB10	Serial Mode. DGND–Digital Ground. Parallel Mode. DB10–Data Input/Output Bit.
37	FSO/DB9	Serial Mode. FSO–Frame Synchronization Output. FSO indicates the beginning of a word transmission on the SDO pin. The FSO signal is a positive pulse approximately one SCO period wide. Parallel Mode. DB9–Data Input/Output Bit.

AD7725

Pin No.	Mnemonic S/P	Description
38	SDO/DB8	Serial Mode. SDO–Serial Data Output. The serial data is shifted out of the AD7725 MSB first, in twos complement format, synchronous with SCO. Parallel Mode. DB8–Data Input/Output Bit.
39	V_{DD}	Digital Power Supply Voltage
40	SCO/DB7	Serial Mode. SCO–Serial Clock Output. The frequency of SCO is a function of the CLKIN frequency and is set by the SCR pin. Parallel Mode. DB7–Data Input/Output Bit.
41	FSI/DB6	Serial Mode. FSI–Frame Synchronization Input. FSI indicates the beginning of a word transmission on the SDI pin. Parallel Mode. DB6–Data Input/Output Bit.
42	INIT/DB5	Serial Mode. INIT–Logic Input. When the device is correctly configured, a logic low on this pin will prevent the device from converting. When this pin is taken high, the device will start converting. When daisy-chaining multiple devices, this pin ensures that all devices sample their analog inputs simultaneously without needing to activate the SYNC pin. Parallel Mode. DB5–Data Input/Output Bit.
43	$\overline{\text{RESETCFG}}$ /DB4	Serial Mode. $\overline{\text{RESETCFG}}$ –Logic Input. $\overline{\text{RESETCFG}}$ is used to reset the part when a configuration error occurs. A low pulse on this pin will reset the part and the configuration file will be downloaded again. The $\overline{\text{SOE}}$ pin will go high following a pulse on the $\overline{\text{RESETCFG}}$ pin and then again following a successful configuration. Parallel Mode. DB4–Data Input/Output Bit.
44	DGND/DB3	Serial Mode. DGND–Digital Ground. Parallel Mode. DB3–Data Input/Output Bit.

TERMINOLOGY**Integral Nonlinearity (INL)**

This is the maximum deviation of any code from a straight line passing through the endpoints of the transfer function. The endpoints of the transfer function are zero scale (not to be confused with bipolar zero), a point 0.5 LSB below the first code transition (100 . . . 00 to 100 . . . 01 in bipolar mode, 000 . . . 00 to 000 . . . 01 in unipolar mode) and full scale, a point 0.5 LSB above the last code transition (011 . . . 10 to 011 . . . 11 in bipolar mode, 111 . . . 10 to 111 . . . 11 in unipolar mode). The error is expressed in LSBs.

Differential Nonlinearity (DNL)

This is the difference between the measured and the ideal 1 LSB change between two adjacent codes in the ADC.

Unipolar Offset Error

Unipolar offset error is the deviation of the first code transition from the ideal $V_{IN}(+)$ voltage, which is $(V_{IN}(-) + 0.5 \text{ LSB})$ when operating in the unipolar mode.

Bipolar Offset Error

This is the deviation of the midscale transition code (111 . . . 11 to 000 . . . 00) from the ideal $V_{IN}(+)$ voltage, which is $(V_{IN}(-) - 0.5 \text{ LSB})$ when operating in the bipolar mode.

Gain Error

The first code transition should occur at an analog value 0.5 LSB above negative full scale. The last code transition should occur for an analog value 1.5 LSB below the nominal full scale. Gain error is the deviation of the actual difference between first and last code transitions and the ideal difference between first and last code transitions.

Signal-to-Noise

SNR is the measured signal-to-noise ratio at the output of the ADC. The signal is the rms magnitude of the fundamental. Noise is the rms sum of all of the nonfundamental signals up to half the output data rate ($F_O/2$), excluding dc. The ADC is evaluated by applying a low noise, low distortion sine wave signal to the input pins. By generating a Fast Fourier Transform (FFT) plot, the SNR data can then be obtained from the output spectrum.

Total Harmonic Distortion (THD)

THD is the ratio of the rms sum of the harmonics to the rms value of the fundamental. THD is defined as:

$$THD = 20 \log \left(\frac{\sqrt{V_2^2 + V_3^2 + V_4^2 + V_5^2 + V_6^2}}{V_1} \right)$$

where V_1 is the rms amplitude of the fundamental and V_2 , V_3 , V_4 , V_5 , and V_6 are the rms amplitudes of the second through sixth harmonics.

Spurious Free Dynamic Range (SFDR)

Defined as the difference, in dB, between the peak spurious or harmonic component in the ADC output spectrum (up to $F_O/2$ and excluding dc) and the rms value of the fundamental. Normally, the value of this specification will be determined by the largest harmonic in the output spectrum of the FFT. For input signals whose second harmonics occur in the stop band region of the digital filter, the spur in the noise floor limits the SFDR.

Setting Time and Group Delay

The settling time of a digital filter is dependent on the amount of decimation employed and the number of filter taps used in the filter design and is calculated as follows:

$$settling\ time = \left(\frac{1}{data\ input\ rate} \right) \times number\ of\ taps$$

The settling time for each filter stage should be calculated separately and then added to get the total filter settling time. Group delay is half the settling time.

AD7725—Typical Performance Characteristics

PERFORMANCE PLOTS

The following typical plots are generated using the digital filter shown in Figure 1.

($AV_{DD} = DV_{DD}$, $T_A = 25^\circ\text{C}$, $CLKIN = 9.6\text{ MHz}$, External Reference = 2.5 V, unless otherwise noted.)

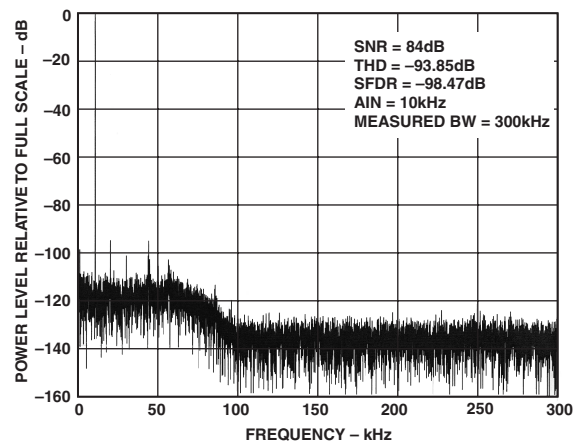
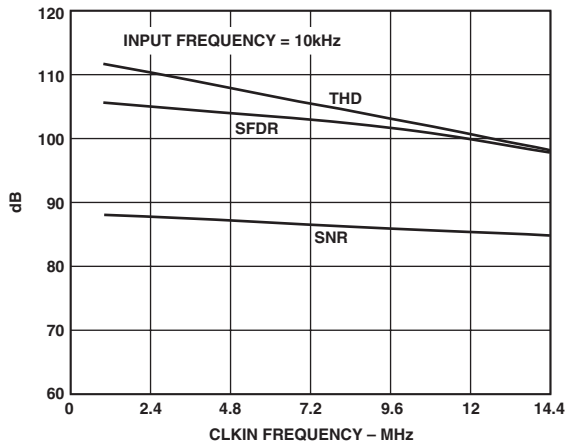
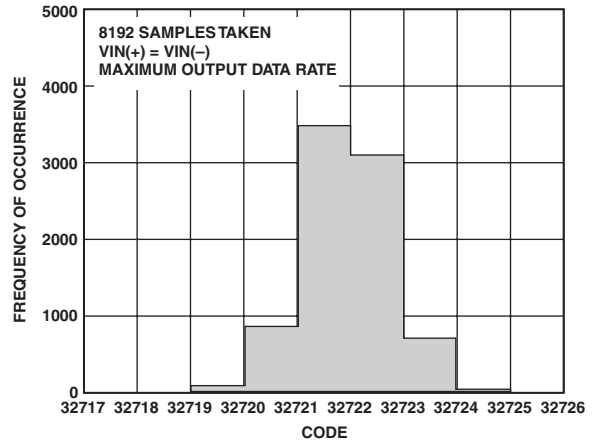
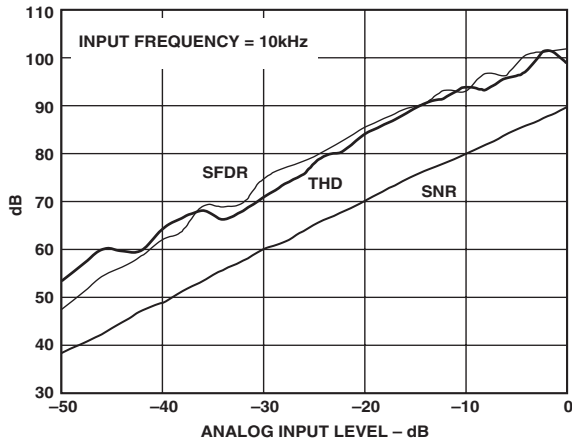

TPC 2. SNR, THD, and SFDR vs. Sampling Frequency

TPC 5. 16k Point FFT

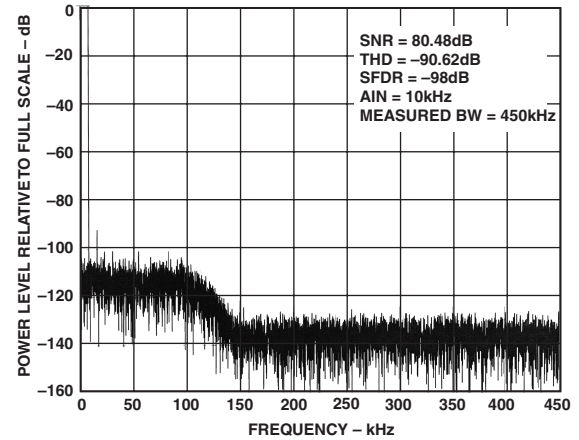
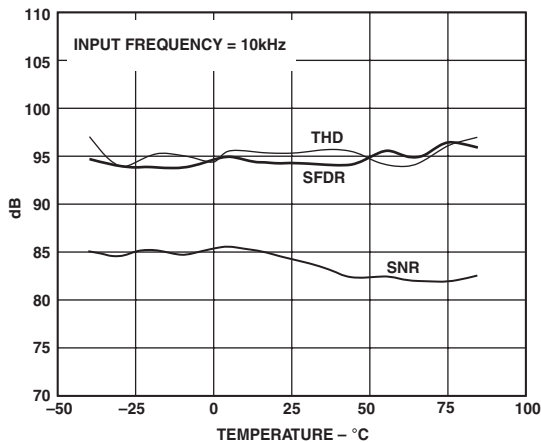

TPC 3. SNR, THD, and SFDR vs. Temperature

TPC 6. 16k Point FFT for a 108 Tap Low-Pass FIR Filter Operating with a CLKIN Frequency of 14.4 MHz

CIRCUIT DESCRIPTION

The AD7725 employs a sigma-delta conversion technique to convert the analog input into an equivalent digital word. The modulator samples the input waveform and outputs an equivalent digital word at the input clock frequency, f_{CLKIN} .

Due to the high oversampling rate, which spreads the quantization noise from 0 to $f_{CLKIN}/2$, the noise energy contained in the band of interest is reduced (Figure 9a). To further reduce the quantization noise, a high order modulator is employed to shape the noise spectrum so that most of the noise energy is shifted out of the band of interest (Figure 9b).

The digital filtering that follows the modulator removes the large out-of-band quantization noise (Figure 9c) while also reducing the data rate from f_{CLKIN} at the input of the filter to $f_{CLKIN}/16$ or less at the output of the filter, depending on the filter type used.

Digital filtering has certain advantages over analog filtering. Since digital filtering occurs after the A/D conversion, it can remove noise injected during the conversion process. Analog filtering cannot do this. The digital filter also has a linear phase response.

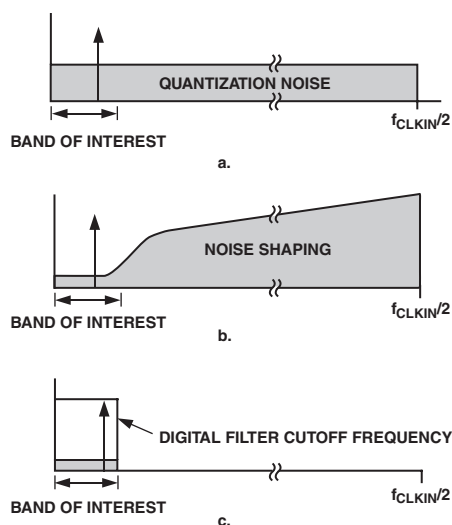

Figure 9. Sigma-Delta ADC

The AD7725 employs three fixed Finite Impulse Response (FIR) filters in series. Each individual filter's output data rate is half that of its input data rate. The fourth stage is programmable, with the user being able to select a range of different filter responses. Both the filter response and the decimation are user programmable. See the Filtering section for more details.

APPLYING THE AD7725

Analog Input Range

The AD7725 has differential inputs to provide common-mode noise rejection. In Unipolar Mode, the analog input is single-ended and its range is 0 V to $(8/5 \times V_{REF2})$. In Bipolar Mode, the analog input is single-ended or differential and its input range is $\pm(4/5 \times V_{REF2})$. The output code is twos complement in both modes with 1 LSB = 61 μ V.

The ideal input/output transfer characteristics for the two modes are shown in Figure 10. In both modes, the absolute voltage on each input must remain within the supply range AGND to AV_{DD} . The Bipolar Mode allows either single-ended or differential input signals while the Unipolar Mode allows single-ended signals.

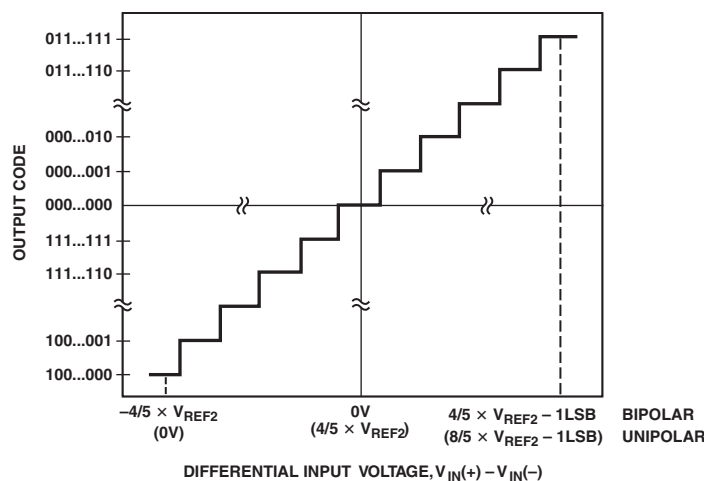

Figure 10. Bipolar/(Unipolar) Mode Transfer Function

The AD7725 will accept full-scale inband signals. However, large scale out-of-band signals can overload the modulator inputs. A minimal single-pole RC antialias filter set to $f_{CLKIN}/24$ will allow full-scale input signals over the entire frequency spectrum.

Analog Input

The analog input of the AD7725 uses a switched capacitor technique to sample the input signal. For the purpose of driving the AD7725, an equivalent circuit of the analog inputs is shown in Figure 11. For each half clock cycle, two highly linear sampling capacitors are switched to both inputs, converting the input signal into an equivalent sampled charge. A signal source driving the analog inputs must be able to source this charge, while also settling to the required accuracy by the end of each half-clock phase.

AD7725

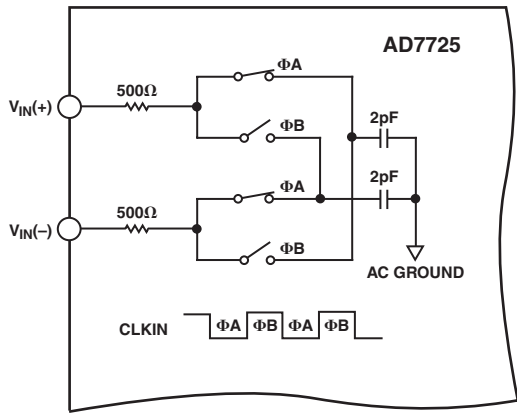

Figure 11. Analog Input Equivalent Circuit

Driving the Analog Inputs

To interface the signal source to the AD7725, at least one op amp will generally be required. The choice of op amp will be critical to achieving the full performance of the AD7725. The op amp not only has to recover from the transient loads that the ADC imposes on it, but it must also have good distortion characteristics and very low input noise. Resistors in the signal path will also add to the overall thermal noise floor, necessitating the choice of low value resistors.

Placing an RC filter between the drive source and the ADC inputs, as shown in Figure 12, has a number of beneficial effects: transients on the op amp outputs are significantly reduced since the external capacitor now supplies the instantaneous charge required when the sampling capacitors are switched to the ADC input pins, and input circuit noise at the sample images is now significantly attenuated, resulting in improved overall SNR. The external resistor serves to isolate the external capacitor from the ADC output, thus improving op amp stability while also isolating the op amp output from any remaining transients on the capacitor. By experimenting with different filter values, the optimum performance can be achieved for each application. As a guideline, the RC time constant ($R \times C$) should be less than a quarter of the clock period to avoid nonlinear currents from the ADC inputs being stored on the external capacitor and degrading distortion. This restriction means that this filter cannot form the main antialias filter for the ADC.

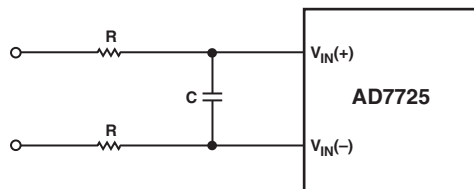

Figure 12. Input RC Network

With the Unipolar Input Mode selected, just one op amp is required to buffer the single-ended input signal to the $V_{IN}(+)$ input and a dc input is applied to the $V_{IN}(-)$ pin to provide an offset. However, driving the AD7725 with differential signals (i.e., the bipolar input range is selected) has some distinct advantages: even order harmonics in both the drive circuits and the AD7725 front end are attenuated, and the peak-to-peak input signal range on both inputs is halved. Halving the input signal range allows some op amps to be powered from the same supplies as the AD7725. An example of providing differential drive to the AD7725 is to use a dual op amp.

Dual Op Amp

Although this differential drive circuit will require the use of two op amps per ADC, it may avoid the need to generate additional supplies just for these op amps.

Figures 13 and 14 show two circuits for driving the AD7725. Figure 13 is intended for use when the input signal is biased about 2.5 V, while Figure 14 is used when the input signal is biased about ground. While both circuits convert the input signal into a differential signal, the circuit in Figure 14 also level shifts the signal so that both outputs are biased about 2.5 V.

Suitable op amps include the AD8047, AD8041 and its dual equivalent the AD8042, or the AD8022. The AD8047 has lower input noise than the AD8041/AD8042 but has to be supplied from a +7.5 V/-2.5 V supply. The AD8041/AD8042 will typically degrade the SNR from 83 dB to 81 dB but can be powered from the same single 5 V supply as the AD7725.

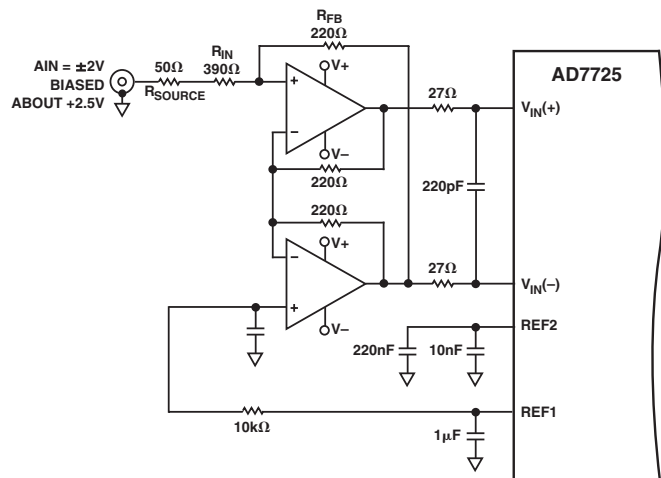

Figure 13. Single-Ended-to-Differential Input Circuit for Bipolar Mode Operation (Analog Input Biased about 2.5 V)

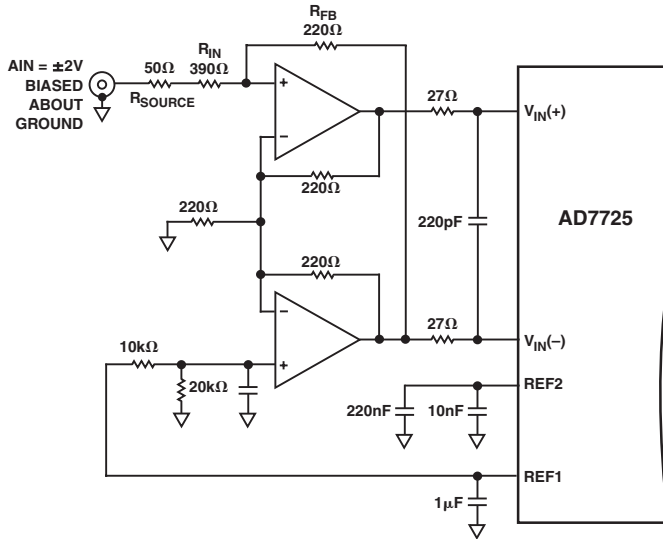

Figure 14. Single-Ended-to-Differential Input Circuit for Bipolar Mode Operation (Analog Input Biased about Ground)

Applying the Reference

The AD7725 can operate with either an external reference or with its on-chip 2.5 V reference. A block diagram of the internal reference circuitry is shown in Figure 15. The internal reference circuitry includes an on-chip 2.5 V band gap reference and a reference buffer circuit. The internal 2.5 V reference voltage is connected to the REF1 pin through a 3 kΩ resistor. It is buffered to drive the analog modulator's switched cap DAC (REF2) as shown in Figure 15. When using the internal reference, a 1 μF capacitor is required between REF1 and AGND to decouple the band gap noise. If the internal reference is required to bias external circuits, an external precision op amp should be used to buffer REF1.

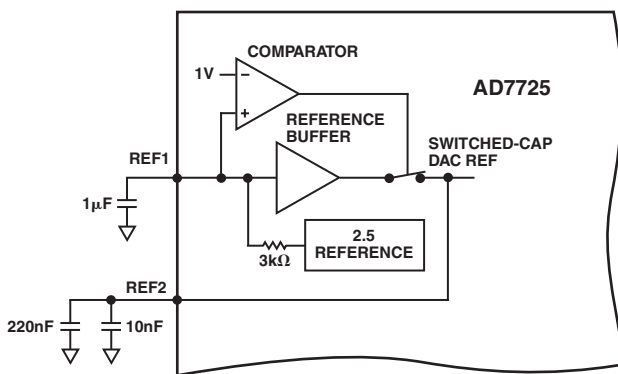

Figure 15. Reference Circuit Block Diagram

Where gain error or gain drift requires the use of an external reference, this can be applied directly to the REF2 pin. In this case, the reference buffer in Figure 15 can be turned off by

grounding the REF1 pin. The AD7725 will accept an external reference voltage between 1.2 V and 3.15 V.

Where the output common-mode range of the amplifier driving the inputs is restricted, the full-scale input signal span can be reduced by applying a lower than 2.5 V reference. For example, a 1.25 V reference would make the bipolar (differential) input range ± 1 V but would degrade SNR.

In all cases, since the REF2 voltage connects to the analog modulator, a 220 nF and 10 nF capacitor must connect directly from REF2 to AGND. The external capacitors provide the charge required for the dynamic load presented at the REF2 pin (see Figure 16).

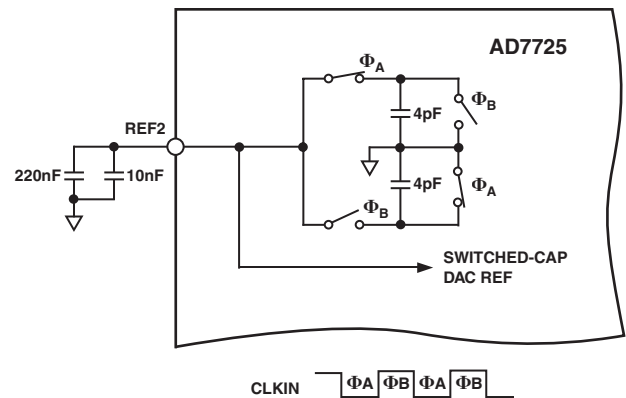

Figure 16. REF2 Equivalent Input Circuit

The AD780 is ideal to use as an external reference with the AD7725. Figure 17 shows a suggested connection diagram. Grounding Pin 8 on the AD780 selects the 3 V output mode.

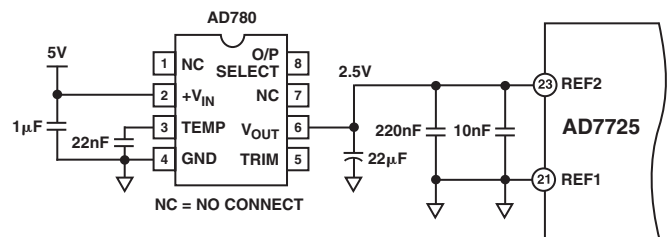

Figure 17. External Reference Circuit Connection

Clock Generation

The AD7725 has an on-chip oscillator circuit to allow a crystal or an external clock signal to generate the master clock for the ADC. In both cases, the clock input has to be continual, i.e., once power is applied to the AD7725, it has to be continually clocked. The connection diagram for use with a crystal is shown in Figure 18. Consult the manufacturer's recommendation for the load capacitors. To enable the oscillator circuit on the AD7725, XTAL_OFF should be tied low.

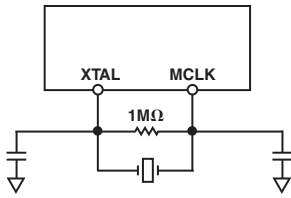

Figure 18. Crystal Oscillator Connection

When an external clock source is being used, the internal oscillator circuit can be disabled by tying XTAL_OFF high. A low phase noise clock should be used to generate the ADC sampling clock because sampling clock jitter effectively modulates the input signal and raises the noise floor. The sampling clock generator should be isolated from noisy digital circuits, grounded, and heavily decoupled to the analog ground plane.

The sampling clock generator should be referenced to the analog ground in a split ground system. However, this is not always possible because of system constraints. In many applications, the sampling clock must be derived from a higher frequency multi-purpose system clock that is generated on the digital ground plane. If the clock signal is passed between its origin on a digital ground plane to the AD7725 on the analog ground plane, the ground noise between the two planes adds directly to the clock and will produce excess jitter. The jitter can cause degradation in the signal-to-noise ratio and also produce unwanted harmonics. This can be remedied somewhat by transmitting the sampling signal as a differential one, using either a small RF transformer or a high speed differential driver and a receiver such as PECL. In either case, the original master system clock should be generated from a low phase noise crystal oscillator.

SYSTEM SYNCHRONIZATION

The SYNC input provides a synchronization function for use in Parallel or Serial Mode. SYNC allows the user to begin gathering samples of the analog input from a known point in time. This allows a system using multiple AD7725s, operated from a common master clock, to be synchronized so that each ADC simultaneously updates its output register. In a system using multiple AD7725s, a common signal to their SYNC inputs will synchronize their operation. When SYNC is high, the digital filter sequencer is reset to zero. A SYNC pulse, one CLKIN cycle long, can be applied. This way, SYNC is sensed low on the next rising edge of CLKIN. When SYNC is sensed low, normal conversion continues. Following a SYNC, the modulator and filter need time to settle before data can be read from the AD7725. Also, when INIT is taken high, it activates SYNC, which ensures that multiple devices cascaded in Serial Mode will sample their analog inputs simultaneously.

FILTERING

The Preset Filter

The preset filter is the digital filter directly following the modulator. This is a fixed filter whose main function is to remove the large out-of-band quantization noise shaped by the modulator. This filter is made up of three cascaded half-band FIR filters, and each filter decimates by two. The word rate into the preset filter is CLKIN, and due to the decimation in the three subsequent filter stages, the output word rate of the preset filter, and thus the input word rate to the postprocessor, is CLKIN/8. See Figure 19.

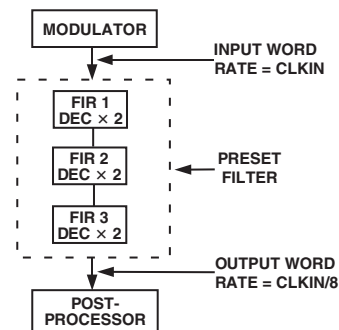

Figure 19. The Preset Filter

The Postprocessor

The AD7725 contains Systolix's PulseDSP™ user-programmable postprocessor. The postprocessor directly follows the preset filter. The postprocessor core is a systolic array of simple high performance processors. These processors are grouped into 36 Multiply Accumulate (MAC) blocks, with each block consisting of three multipliers and one adder. Each block can process three filter taps, thus the postprocessor allows up to $36 \times 3 = 108$ filter taps. In a systolic array, numerical data is pumped around processors. Each of these processors is allocated to a dedicated function and only performs that single function. The data is passed between processors and, in this manner, complex operations are performed on the input signal. In the AD7725, data transfers between processors are fully synchronous. As a result, the user does not have to consider timing issues.

The postprocessor core is optimized for signal conditioning applications. In this type of application, generally the most common function is filtering. The core can support any filter structure, whether FIR, IIR, recursive, or nonrecursive. The core also supports polynomial functions, commonly used in linearization algorithms.

Data can be transparently decimated or interpolated when passed between processors. This simplifies the design of multirate filtering and gives great flexibility when specifying the final

output word rate. The AD7725 postprocessor supports decimation/interpolation by factors up to 256.

Figure 20 shows an example of a filtering function implemented on the postprocessor. Figure 20a shows the data path representation of an FIR filter, while Figure 20b shows how this algorithm would be implemented on the AD7725. Because the postprocessor can implement three filter taps per MAC block, 1.3 MAC blocks are required to implement a 4-tap FIR filter. This is a useful guideline when calculating the design requirements for a new application.

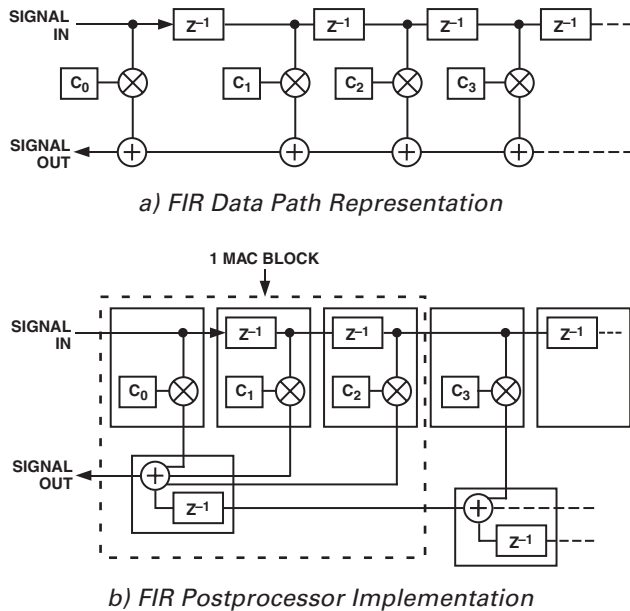

Figure 20. AD7725 Postprocessor Mapping

PROGRAMMING THE POSTPROCESSOR

The postprocessor is programmed by loading a user-defined filter in the form of a configuration file into the device.

Generating a Configuration File to Load into the Postprocessor

A user-defined configuration file can be generated to load into the postprocessor on the AD7725 to program the multipliers and accumulators to perform user-specific filtering requirements. The configuration file can be generated using a digital filter design package called Filter Wizard, which is available from the Analog Devices website.

Filter Wizard

This digital filter design package allows the user to design different filter types and then generates the appropriate configuration file to be loaded into the postprocessor. This application includes the ability to specify a range of different filter options including single or multistage; normalized or user-specified output frequency; FIR or IIR; low-pass, band-pass; Window type; pass-band frequency and ripple; stop-band frequency, attenuation and ripple; daisy-chaining and interlacing. It also informs the user of the power dissipation of the AD7725 associated with the particular filter designed. This is to avoid filters being designed that result in the device exceeding its maximum power specifica-

tions. The magnitude, phase, and impulse responses can be plotted so that the user knows the filter response (cutoff frequency, transition width, attenuation) before generating the coefficients. Once the filter characteristics have been decided, the configuration file is generated and will be ready for loading into the postprocessor.

Filter Configuration File Format

The configuration file that is generated by the Filter Wizard is made up of 8272 bits of data. The first word in the file is called the ID word, and the device will only accept the configuration file if this is 0x7725. The rest of the configuration data is split into 12 blocks of 672 bits. The AD7725 postprocessor therefore accepts 672 bits at a time (42, 16-bit words). Each block of 672 bits is followed by a Cyclic Redundancy Check (CRC) word. The ID word and the CRC words are used by the device to check for errors in the configuration file and are not actually written to the postprocessor. The postprocessor therefore holds 8064 bits of data (672×12). See the Serial Mode and Parallel Mode sections for further information on how configuration errors are detected and handled. The filter coefficients in the configuration file that are loaded into the postprocessor have 24 bits precision and have a value in the range $-8 \leq \text{coefficient} < +8$. The coefficients are made up of one sign bit, three magnitude bits left of the decimal point, and 20 right of the decimal point.

Using the Internal Default Filter

The AD7725 has a default filter stored in internal ROM that can be loaded into the postprocessor. This functionality allows the user to evaluate the device without having to download a configuration file. The default filter is a two-stage, low-pass, FIR filter whose specifications are directly related to the CLKIN frequency. With a CLKIN frequency of 9.6 MHz, the default filter has a cutoff frequency of 49 kHz and a stop-band frequency of 72.7 kHz. This filter has a total decimation by four, which occurs in the first stage, resulting in the output data being available to the interface at a frequency of $\text{CLKIN}/32$. For more detailed specifications on this filter see the Preset Filter, Default Filter, and Postprocessor Characteristics section. When powered up in Boot-from-ROM Mode, the AD7725 will automatically load the default filter characteristic into the postprocessor. Figure 21 shows the default filter response, when operating with a 9.6 MHz CLKIN frequency.

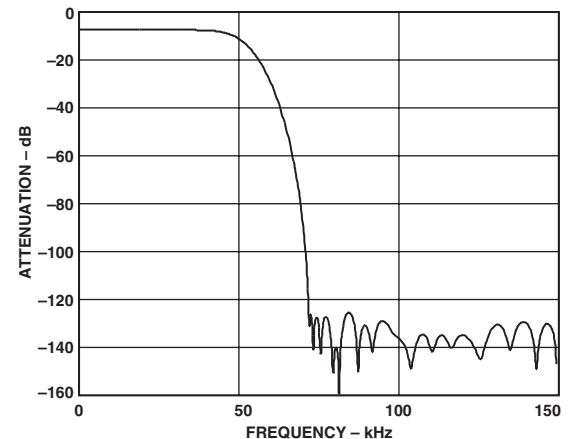

Figure 21. Default Filter Response for CLKIN = 9.6 MHz

AD7725

Filter Design

The bit stream of data from the modulator and preset filter is available to the postprocessor at a frequency of CLKIN/8. Due to the nature of the design of the postprocessor, there is an unavoidable minimum decimate by two resulting in the maximum output data rate of any filter being CLKIN/16.

A filter can be either FIR or IIR in design. FIR filters are inherently stable and have linear phase. However, they are computationally inefficient and require more coefficients for a given roll-off compared to IIR filters. IIR filters have the disadvantage of being potentially unstable and having nonlinear phase. The maximum number of taps that the postprocessor can hold is 108. Therefore, a single filter with 108 taps can be generated, or a multistage filter can be designed whereby the total number of taps adds up to 108.

Design Factors

(i) Stop-Band Attenuation and Transition Width

In filter design, it is desirable to have a large stop-band attenuation and a narrow filter transition width. To achieve both of these, a large number of filter taps is required. Therefore some compromises have to be made during the design to be able to optimize the amount of taps used. There is usually a trade-off of stop-band attenuation for transition width, or vice versa. For example, a filter with a cutoff frequency of 100 kHz that rolls off between 100 kHz and 200 kHz uses fewer taps than a filter with a cutoff frequency of 100 kHz that rolls off between 100 kHz and 150 kHz. To reduce the number of taps used to achieve a certain specification, a multistage filter can be designed that performs decimation between stages. The first filter stage can be used to perform decimation and as a prefilter to remove out-of-band noise, then the subsequent stages can have more stringent specifications.

(ii) Decimation

Decimation reduces the output data rate of the filter, resulting in lower input data rates for subsequent filter stages. When decimation is used in a multistage filter, the noise is wrapped around $f_s/2$ each time the bit stream is decimated by two. It is therefore important to appropriately filter out the quantization noise that will wrap into the band of interest when decimation occurs, prior to decimation. With appropriate filtering, the noise floor will increase by 3 dB each time the data stream is decimated by two; however the noise floor is down at 120 dB prior to decimation. Therefore, with suitable decimation, the SNR will be 83 dB typically at the AD7725 output.

Decimating the data rate allows an improvement in the filter transition width equal to the inverse of the decimation factor. For FIR filters, if a filter is designed for an input data rate of half the maximum data rate, i.e., the previous filter stage had decimation by two, the filter can obtain half the transition width of a filter designed for the maximum input data rate for a given number of taps. For example, the number of taps required to generate a filter with a cutoff frequency of 100 kHz and a stop-band frequency of 200 kHz will equal the number of taps required to generate a filter with a cutoff frequency of 100 kHz and a stop-band frequency of 150 kHz if the data stream is

decimated by two prior to the filtering stage. For IIR filters, decimation has no effect on the transition width.

When decimation is performed, the amount of filter coefficients required to achieve certain filter specifications is reduced, resulting in a reduction in the power dissipation of the device to realize the filter. Therefore, if a one-stage filter meets the roll-off and stop-band attenuation requirements of the application but is dissipating more power than is acceptable, then decimation will provide a solution here. Prior to decimating, a suggestion is to use a half-band filter as these require a low number of taps to accomplish simple low-pass filtering. A half-band filter has its midpoint of the transition region centered on half the Nyquist frequency (or $f_s/4$). By decimating though, because the input to subsequent stages is reduced, so is the bandwidth.

Figure 22 shows that for a given transition width, as the decimation factor prior to the filter is increased the current consumption is reduced, resulting in reduced power dissipation.

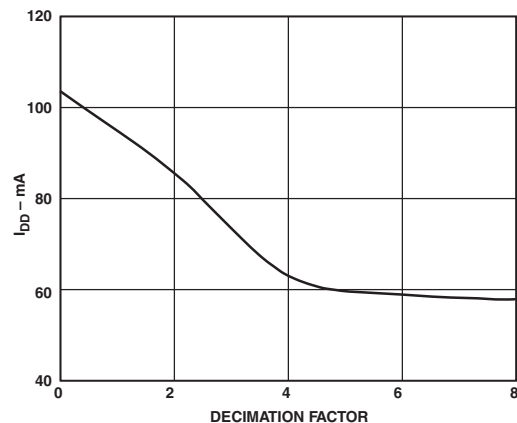

Figure 22. I_{DD} vs. Decimation for a Filter with a Transition Width of 66 kHz as Shown in Figure 1

Power Consumption vs. Filter Taps vs. CLKIN Frequency

When designing filters for the AD7725, an important factor to take into account is the power consumption. There is a direct relationship between DI_{DD} , the number of filter taps used in the postprocessor, and the CLKIN frequency. The maximum I_{DD} (combined AI_{DD} and DI_{DD}) allowed by the AD7725 package is 150 mA. The more filter taps used, the higher the DI_{DD} . Also, the higher the CLKIN frequency, the higher the DI_{DD} . Therefore, a trade-off sometimes needs to be made between CLKIN frequency and filter taps to stay within the power budget of the part.

These power constraints are built into the filter design package, Filter Wizard. As the filter is being designed, the power consumption is shown and is highlighted once the power budget has been exceeded.

Figures 23 and 24 show plots of filter taps and CLKIN frequency versus I_{DD} .

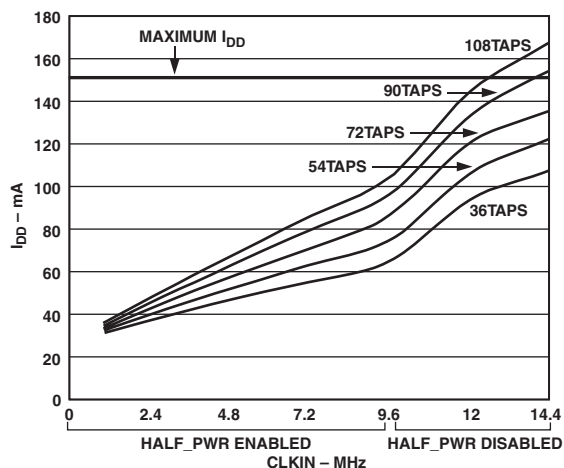

Figure 23. Typical I_{DD} vs. CLKIN for Various Numbers of Filter Taps

To get a more accurate number of taps for a given CLKIN frequency, see Figure 24.

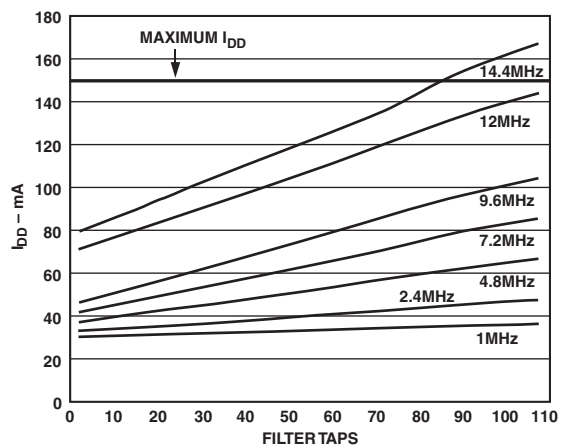

Figure 24. Typical I_{DD} vs. Filter Taps for Various CLKIN Frequencies

Figures 23 and 24 were done for a 1-stage low-pass FIR filter, which will give the worst case I_{DD} figures.

The I_{DD} will decrease as the amount of decimation employed in the filter is increased.

MODES OF OPERATION

The AD7725 can operate with either a serial or a parallel interface. These modes are chosen by setting the logic state of the S/\bar{P} pin.

PARALLEL MODE

The Parallel Mode is selected by tying S/\bar{P} to DGND. Programming the postprocessor and operation of the AD7725 in Parallel Mode requires the use of an instruction set. The user also has access to an on-chip status register that provides information about the operation of the device. The parallel interface is a standard interface that interfaces to digital signal processors and microprocessors. Figure 25 shows the interface between the AD7725 and a DSP/microprocessor, and Figures 6, 7, and 8 show the timing of the parallel interface.

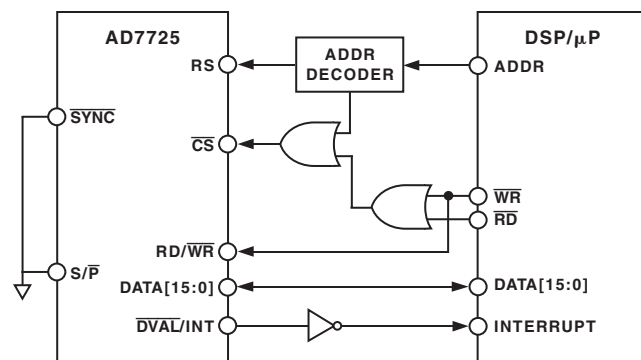

Figure 25. AD7725 Parallel Interface to Microprocessor

Operating the AD7725 in Parallel Mode

The AD7725 uses an instruction set, its interrupt output (the INT pin), and an on-chip status register to communicate with the DSP/microprocessor. An interrupt is issued by the AD7725 whenever user intervention is required. The interrupt can be cleared by either writing an instruction or reading the status register. At the completion of power on reset, the AD7725 will issue an interrupt to indicate that user intervention is required for it to begin communicating with the DSP/microprocessor. An instruction should then be issued to load the configuration data to program the postprocessor. Once the configuration file has been loaded, another interrupt is issued by the device. The status register can then be read to check if any errors occurred during configuration. If no errors occur during the configuration process, an instruction can be issued to inform the device to begin converting.

Pins $\overline{RD}/\overline{WR}$, \overline{CS} , and RS are used along with the data pins D0 to D15 to write instructions/configuration data and read the status register/conversion data.

During a read cycle, the RS pin informs the AD7725 whether the status register or a conversion result is being read. When RS is high, the status register is read while the data register, such as the device ID or a conversion result, is read when RS is low. Similarly, during a \overline{WR} cycle, an instruction is written when RS is high and data (such as configuration data) is written when RS is low (See Table I).

Table I. Reading and Writing

$\overline{RD}/\overline{WR}$ (Pin 7)	RS (Pin 4)	Operation
0	0	Write Data
0	1	Write Instruction
1	0	Read Data
1	1	Read Status Register

AD7725

The Status Register

The status register is a 16-bit register that provides the user with information about the status of the device. The information available to the user includes whether a configuration file was loaded successfully, what errors occurred if any, the last instruction written, and other information that may be useful to the user when operating the device. To read the status register, RS is taken high and RD/ $\overline{\text{WR}}$ is taken high. When $\overline{\text{CS}}$ is taken low, the contents of the status register will be output. The status register is shown in Table II and the instruction set in Table III.

Table II. Status Register

Bit	Name	Function
15	InstrBUSY	This bit is set to 1 when an instruction is being performed.
14	Data Ready	This bit is set to 1 when data is ready to be read from the device (i.e., a Read Data cycle is required).
13	Data Request	This bit is set to 1 when the device requires data to be written to it (i.e., a Write Data cycle is required).
12	ID Error	This bit is set to 1 if the programming data has an incorrect ID Value.
11	CRC Error	This bit is set to 1 if corrupt data is loaded into the device.
10	Data Error	This bit is set to 1 if an overflow occurs to indicate that the conversion result is invalid.
9	InstrReg[15]	Instruction Register Bit 15
8	InstrReg[13]	Instruction Register Bit 13
7	InstrReg[12]	Instruction Register Bit 12
6	InstrReg[11]	Instruction Register Bit 11
5	InstrReg[6]	Instruction Register Bit 6
4	InstrReg[5]	Instruction Register Bit 5
3	InstrReg[4]	Instruction Register Bit 4
2	InstrReg[1]	Instruction Register Bit 1
1	InstrReg[0]	Instruction Register Bit 0
0	CFGEND	Configuration End Flag. This is set to 1 when the device has been configured correctly and is ready to start converting.

Table III. Instruction Set for Use in Parallel Mode

Instruction	Hex Code	Description
RdID	0x8802	Read Device ID
RdCONV	0x8D21	Read Converter Data. When this instruction is issued to the AD7725, the device continues to output conversion data until the ABORT instruction is issued.
WrConfig	0x1800	Write Configuration Data
WrConfigEM	0x1A00	Write Configuration Data, Mask Errors
ABORT	0x0000	Abort. This instruction is a soft reset, i.e., it breaks the conversion process and leaves the device in a clean state, still configured, ready for the next instruction.
BFR	0x2000	Boot from Internal ROM

Configuring the Device

Following power-up, the AD7725 is configured by loading a user-defined filter from an external source via the parallel interface. Three instructions are provided for configuring the AD7725 (see Table III).

(i) WrConfig (Write Configuration)

When this instruction is issued, the device generates an interrupt every time a new word of the configuration data is required. The interrupt is cleared on the falling edge of $\overline{\text{CS}}$ during the data write cycle. This continues until the complete file is written. Immediately after the last word of the configuration data is written, a final interrupt is asserted to indicate “Instruction Done.”

However, if an error occurred during the configuration process, e.g., if the configuration data is corrupt or in the wrong format, an interrupt will be asserted.

It is advised that when using this instruction, the Status Register is read after each interrupt to ensure no errors occurred and that the correct response is made. If configuration data is corrupt, it will not be internally written to the postprocessor.

(ii) WrConfigEM (Write Configuration with Error Mask)

When this instruction is issued, no interrupts to signal errors will ever be asserted during the download of the configuration file. This saves reading the status register in response to every interrupt as with the previous instruction. The configuration process will always run through the 504 (42 writes \times 12 blocks) data write cycles in the configuration file and once this is complete, the “Instruction Done” interrupt is issued. In this case, the status register should be checked at the end of the configuration to verify whether any errors occurred. If configuration data is corrupt, it will not be internally written to the postprocessor.

For evaluation purposes, the user can load the default filter stored in internal ROM into the postprocessor. In this case the following instruction should be issued:

(iii) BFR (Boot from ROM)

This instruction informs the device to load the configuration data for the default filter stored in internal ROM.

Converting

To begin conversions, the RdCONV (Read Converter Data) instruction is issued (see Table III). INT is asserted as soon as the conversion data is ready to be read (Bit 14 of the status register will be set). INT remains high until the digital word is read from the device. It will then go low and return high when the next conversion is complete. The device continues to convert until the ABORT instruction is issued.

SERIAL MODE

The Serial Mode is selected by tying S/\bar{P} to DV_{DD} . Figure 4 shows the serial interface of the AD7725. The AD7725 operates solely as a master providing two serial data input pins for the transfer of configuration data into the device (FSI and SDI), two serial data output pins for transfer of conversion data out of the device (FSO and SDO), and a serial clock output (SCO). Data is shifted in or out of the device synchronous with SCO. The FSI and FSO signals are used to indicate to either the device or the processor the beginning of a word transmission into or out of the device. The AD7725 provides the clock for conversion and data transfers. The CFMT pin selects the active edge of SCO during conversions and the EFMT pin selects the active edge of SCO during configuration.

Programming the postprocessor and operating the AD7725 in Serial Mode is purely pin-driven. Serial Mode has three different submodes that determine the way in which the postprocessor is to be configured following power-up. These modes are selected by setting the logic values on the SMODE0 and SMODE1 pins (see Table IV). These modes are:

- (i) DSP: The filter can be user defined and can be loaded from a DSP.
- (ii) EPROM: The filter can be user defined and can be loaded from an external EPROM.
- (iii) Boot from ROM (BFR): The default filter (stored in internal ROM) can be loaded into the postprocessor, which allows the user to evaluate the device without having to load configuration data.

In Serial Mode, several AD7725s can be daisy-chained together so they can all be configured from one EPROM or DSP and conversion data from all devices can be read back by one DSP.

DSP Mode—Loading Configuration Data from a DSP

In this mode, a user-defined filter can be developed and the resulting configuration file loaded into the postprocessor from a DSP. The DSP therefore loads data into the AD7725 and reads back the conversion results. This mode of operation is selected by tying SMODE0 to DV_{DD} and SMODE1 to DGND. The values on these pins inform the AD7725 that user-defined filter data is to be loaded into the postprocessor from the DSP automatically following power-up. The data is loaded using FSI and SDI and the transfer of data is controlled by SCO. Following power-on reset, the \overline{SOE} pin goes high to inform the DSP that configuration of the postprocessor can begin. If no errors occur during the configuration, the CFGEND output will go high. In Figure 26,

the CFGEND is tied to INIT, thus it will drive INIT high and the part will begin converting. However, if an error does occur during the configuration, the \overline{ERR} bit will go low and CFGEND will not go high. The INIT pin will therefore not start conversions. The part will not do anything until $\overline{RESETCFG}$ is pulsed low. When this occurs, the part is reset, \overline{SOE} goes high, and the configuration file is reloaded.

The AD7725 will read the entire configuration file and if an error does occur during configuration, the user will only be notified once the whole file has been read. In this case, the data will not be loaded into the postprocessor. The serial clock frequency (SCO) is selected by the value on SCR and can be CLKIN (SCR = 0) or CLKIN/2 (SCR = 1). SCO must have a frequency equal to CLKIN if the AD7725 outputs data at CLKIN/16. For lower output word rates, either clock frequency can be used. To load configuration data into the AD7725, an FSI pulse one CLKIN cycle wide informs the AD7725 that data is being transferred into the device. The data is loaded using the next 16 SCLK cycles following the detection of the FSI pulse. Figure 26 shows the connection diagram for the AD7725 when loading configuration data from a DSP, and Figure 27 shows a flow chart of the power-up and configuration sequence.

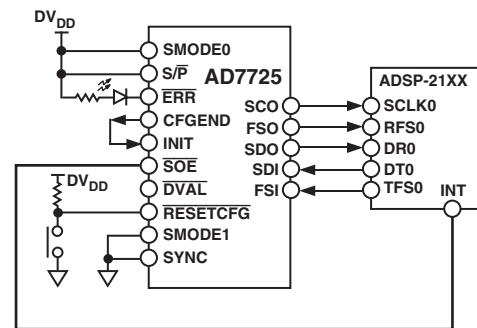

Figure 26. Connection Diagram for Loading the Filter Configuration Data from a DSP

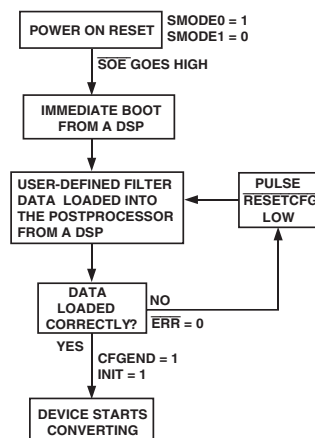

Figure 27. Flow Chart of DSP Mode

EPROM Mode—Loading Configuration Data from an External EPROM

In this mode, a user-defined filter can be developed off-chip and the resulting configuration file is loaded into the postprocessor

Table IV. Programming Modes

S/P	SMODE[1, 0]	Configuration Mode	Description
0	xx	PARALLEL	Parallel Interface. The 16-bit bidirectional microprocessor. Interface is used for Read/Write operations.
1	00	BFR	Serial Interface. Boot from the default filter (Internal ROM) at power-on reset (POR).
1	01	DSP	Serial Interface. Bidirectional serial synchronous interface suitable for interfacing to a DSP.
1	10	EPROM	Serial Interface. Boot from external serial EPROM at POR.
1	11	EPROM	Serial Interface. Boot from external serial EPROM at POR.

in the AD7725 from an External EPROM. The AD7725 therefore receives filter data from an EPROM before outputting conversion results via the serial interface to a DSP. This mode of operation is selected by tying SMODE0 to DGND and SMODE1 to DV_{DD}. The values on these pins inform the AD7725 that user-defined filter data is to be loaded from an external EPROM automatically on power-up. Following power-up, the AD7725 will drive the \overline{SOE} pin low, which will enable the EPROM and reset its address counter. The transfer of the configuration data will then commence with the data being latched into the AD7725 on the SCO rising edge. During the download of data, SCO has a frequency of CLKIN/8. FSI is not used in the data transfer, so it should be tied low. Once configuration is complete and no error occurred, \overline{SOE} will go high, disabling the EPROM; SCO will return to either CLKIN or CLKIN/2, depending on SCR; and CFGEND will go high driving the INIT pin high and the device will start converting. However, if an error does occur during the configuration, the \overline{ERR} bit will go low and CFGEND will not go high. The part will not do anything until $\overline{RESETCFG}$ is pulsed low. When this occurs, the part is reset, \overline{SOE} goes low again to enable the EPROM, and the part is reconfigured. Figure 28 shows the connection diagram for the AD7725 when loading configuration data from an EPROM, and Figure 29 shows a flow chart of the power-up and configuration sequence.

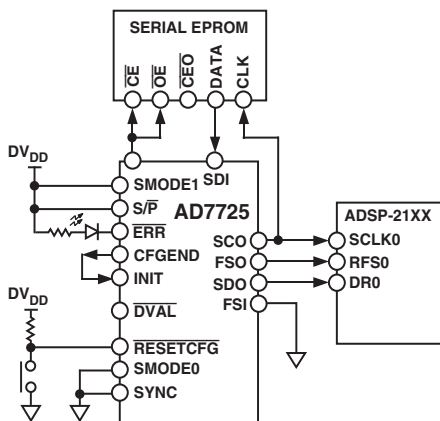

Figure 28. Connection Diagram for Loading the Filter Configuration Data from an External EPROM

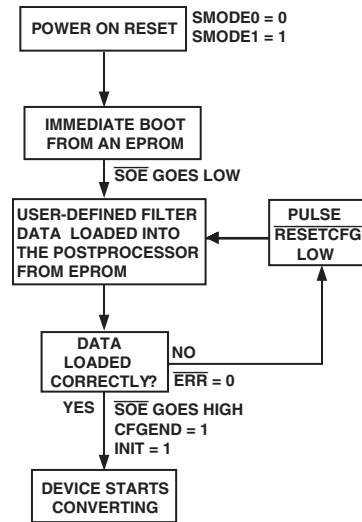

Figure 29. Flow Chart of EPROM Mode

Boot from ROM Mode (BFR)–Using the Internal Default Filter

This mode of operation allows the user to evaluate the AD7725 without having to load configuration data. It is selected by tying SMODE0 and SMODE1 to DGND. The values on these pins inform the AD7725 that the postprocessor is to be configured with the default filter stored in internal ROM. The default filter data will be loaded into the postprocessor automatically following power up. Once the configuration is complete, the CFGEND pin will go high. In Figure 30, CFGEND is tied to INIT, thus it will drive the INIT pin high and the AD7725 will begin converting.

FSI and SDI are not used in this mode, so they should be tied to DGND. In this mode of operation, the AD7725 operates as a normal sigma-delta ADC with a fixed filter response.

During configuration, SCO will have a frequency of CLKIN/16. Once configuration is complete, the frequency of SCO is selected by SCR and will be either CLKIN or CLKIN/2. Additionally, the SCO edge on which the data is output from the device can be selected using CFMT. With SCR = 0, SCO equals CLKIN. With SCR = 1, SCO equals CLKIN/2. With CFMT = 0, data is output on the SCO rising edge, while data is output on the falling edge when CFMT = 1. Figure 30 shows the connection diagram for the AD7725 when using the internal default filter, and Figure 31 shows a flow chart of the power-up and configuration sequence.

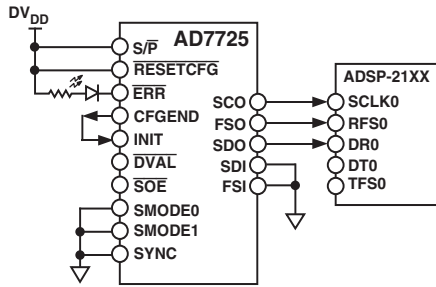

Figure 30. Connection Diagram for Loading the Default Filter in BFR Mode

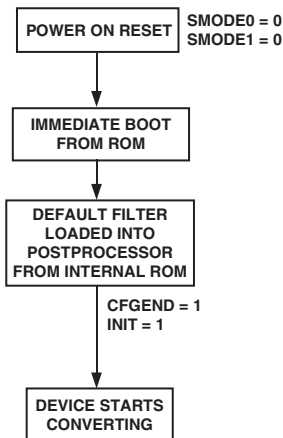

Figure 31. Flow Chart of BFR Mode

Daisy-Chaining Devices

Several AD7725s can be daisy-chained/cascaded together. This feature of the AD7725 reduces system demands as it allows several devices to be configured using one serial data stream. It also allows conversion data from several devices to be read back by a single DSP as one serial data stream. When devices are daisy-chained, configuration/conversion data flows from device to device using the SDO/FSO and SDI/FSI pins of each device. A specific daisy-chaining configuration file needs to be developed using the filter design package Filter Wizard. There are a few different daisy-chaining options for the user to choose from:

(i) Daisy-Chaining during Configuration

Several AD7725s can be daisy-chained together so that they can all be configured from a common external serial EPROM or a DSP. Filter Wizard allows the user to specify the number of devices in the chain and to design a specific filter for each device. It then generates a separate configuration file for each device. The configuration files for all the

devices can be combined into one configuration file (in order, starting with the file for the first device), e.g., with a text editor, so that the user only has to load one file into the EPROM or DSP. This configuration file is loaded into the devices using the FSI/SDI and the FSO/SDO of each device. Once the devices have been configured in a daisy chain, each device can be run independently and conversion data is read back using the FSO and SDO from each device separately.

(ii) Daisy-Chaining—Configuration and Conversion Data

Several AD7725s can be daisy-chained so that they are configured from a common external serial EPROM or DSP (as discussed in (i) above) and all conversion data from each individual device can be read back by a single DSP on one serial data stream. To do this, an interlacer is required following each filter on each device. This design can be implemented using Filter Wizard. The function of the interlacer is to sequentially combine the conversion data outputs of each device into one serial data stream. The interlacer combines the data using interpolation and summing. Interpolation pads the data with zeros; then the interlacer takes the output data from the previous device, delays it by one clock cycle and sums it with the interpolated output from the current device. This occurs on each device in the chain and the output data from the last device consists of all the devices' conversion data in one continuous data stream. When designing filters with interlacing, the decimation rate of the filter on each device should be twice the number of devices in the chain, or a multiple of this value, to ensure there is no interference between the conversion data of different devices.

Due to the interpolation and decimation, the effective output data rate of each device (out of the last device) is $CLKIN / (16 \times \text{no. of devices})$ and the actual output data rate of the final device is $CLKIN / 16$. Once the daisy-chaining and interlacing design is complete, one configuration file is generated to be loaded into the devices. Figure 32 shows an example of daisy-chaining three devices, using interlacing.

Loading Configuration Data

When loading the configuration file from a common EPROM or DSP, the configuration data is loaded into the first device in the chain. Once this device is configured, the data will be loaded into the second device in the chain via FSO/SDO of Device 1 and FSI/SDI of Device 2. When this device is configured, the data is loaded into the next device in the chain until all devices are configured. The CFGEND pin of the last device is connected to the INIT pin of all the devices so that when the last device is successfully configured, conversions are initiated.

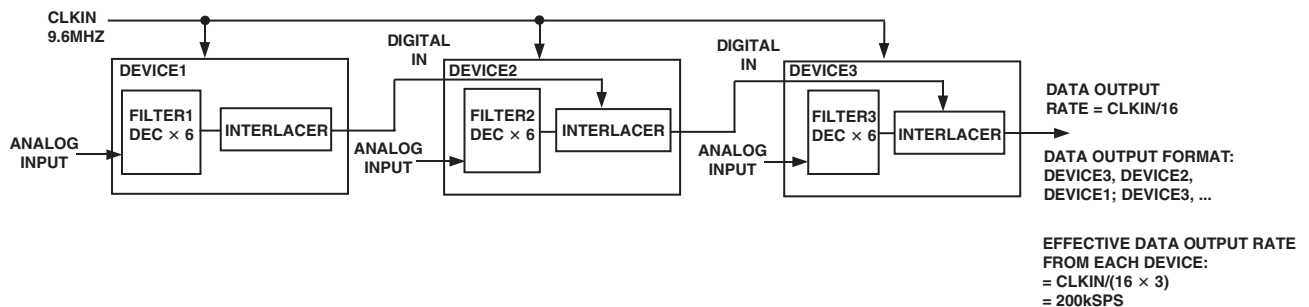

Figure 32. Daisy-Chaining Example

AD7725

Converting

When the ADCs are converting, the conversion result of the first device in the chain is sent to the second device and is combined with the conversion data of the second device by the interlacer. This data is then combined with the data from the next device in the chain, and so on. The output from the last device will be a continuous serial data stream consisting of the conversion results of all the devices in the chain. A single DSP can read back all the conversion data in the sequence:

Device N; ... Device 2; Device 1; Device N; ... Device 2; Device 1; and so on.

Figure 33 shows a connection diagram for daisy-chaining multiple devices with a common DSP, and Figure 34 shows a connection diagram for daisy-chaining multiple devices with a common DSP and a shared EPROM.

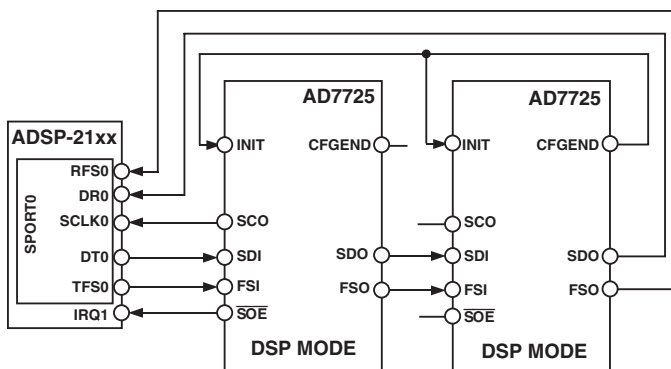

Figure 33. Daisy-Chaining Devices with a Common DSP

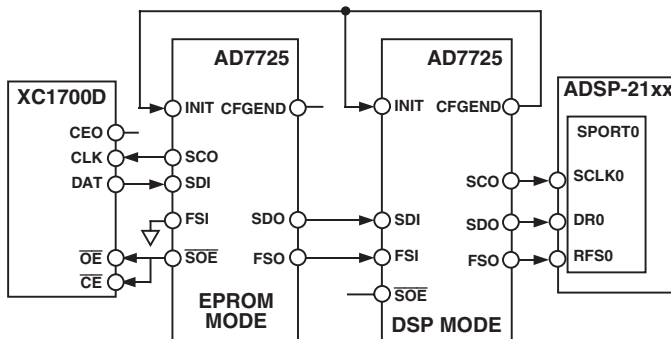

Figure 34. Daisy-Chaining Devices with a Common DSP and a Shared EPROM

(iii) Cascading Filters across Multiple Devices

If the design of your filter is too large for one AD7725 device to handle, the filter can be cascaded across multiple devices. For example, if you have a 3-stage filter in your design that requires over 108 taps to be implemented, this filter can be shared between two or three devices. To do this, a configuration file needs to be developed in Filter Wizard. Filter Wizard allows the user to split the filter stages up and implement them on different devices with the output of the final device being the filtered input of the first device.

SERIAL INTERFACE TO A DSP

In Serial Mode, the AD7725 can be directly interfaced to several industry-standard digital signal processors. In all cases, the AD7725 operates as the master with the DSP operating as a slave. The AD7725 provides its own serial clock (SCO) to transmit the digital words on the SDO pin to the DSP. The AD7725 also generates the frame synchronization signal that synchronizes the transfer of the 16-bit word from the AD7725 to a DSP. SCO will have a frequency equal to CLKIN or CLKIN/2 depending on the state of the SCR pin.

AD7725 to ADSP-21xx Interface

Figure 35 shows the interface between the ADSP-21xx and the AD7725. For the ADSP-21xx, the bits in the serial port control register should be set up as RFSR and TFSR = 1 (a frame sync is required for each data transfer), SLEN = 15 (16-bit word lengths), RFSW and TFSW = 0 (normal framing mode for receive and transmit operations), INVRFS and INVTFS = 0 (active high RFS and TFS), IRFS = 0 (external RFS), ITFS = 1 (Internal TFS), and ISCLK = 0 (external serial clock).

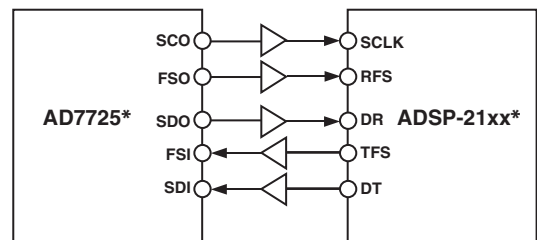

*ADDITIONAL PINS OMITTED FOR CLARITY

Figure 35. AD7725 to ADSP-21xx Interface

GROUNDING AND LAYOUT

The analog and digital power supplies to the AD7725 are independent and separately pinned out to minimize coupling between analog and digital sections within the device. All the AD7725 AGND and DGND pins should be soldered directly to a ground plane to minimize series inductance. In addition, the ac path from any supply pin or reference pin (REF1 and REF2) through its decoupling capacitors to its associated ground must be made as short as possible (Figure 36). To achieve the best decoupling, place surface mount capacitors as close as possible to the device, ideally right up against the device pins.

To avoid capacitive coupling, ground planes must not overlap. The AD7725's digital and analog ground planes must be connected at one place by a low inductance path, preferably right under the device. Typically, this connection will either be a trace on the printed circuit board of 0.5 cm wide when the ground planes are on the same layer, or 0.5 cm wide minimum plated through holes when the ground planes are on different layers. Any external logic connected to the AD7725 should use a ground plane separate from the AD7725's digital ground plane. These two digital ground planes should also be connected at just one place.

Separate power supplies for AV_{DD} and DV_{DD} are also highly desirable. The digital supply pin DV_{DD} should be powered from a separate analog supply, but if necessary DV_{DD} may share its power connection to AV_{DD}.

A minimum etch technique is generally best for ground planes as it gives the best shielding. Noise can be minimized by paying attention to the system layout and preventing different signals from interfering with each other. High level analog signals should be separated from low level analog signals, and both should be kept away from digital signals. In waveform sampling and reconstruction systems, the sampling clock (CLKIN) is as vulnerable to noise as any analog signal. CLKIN should be isolated from the analog and digital systems. Fast switching signals like clocks should be shielded with their associated ground to avoid radiating noise to other sections of the board, and clock signals should never be routed near the analog inputs.

Avoid running digital lines under the device, as these will couple noise onto the die. The analog ground plane should be allowed to run under the AD7725 to shield it from noise coupling. The power supply lines to the AD7725 should use as large a trace as possible (preferably a plane) to provide a low impedance path and reduce the effects of glitches on the power supply line.

Avoid crossover of digital and analog signals. Traces on opposite sides of the board should run at right angles to each other. This will reduce the effects of feedthrough through the board.

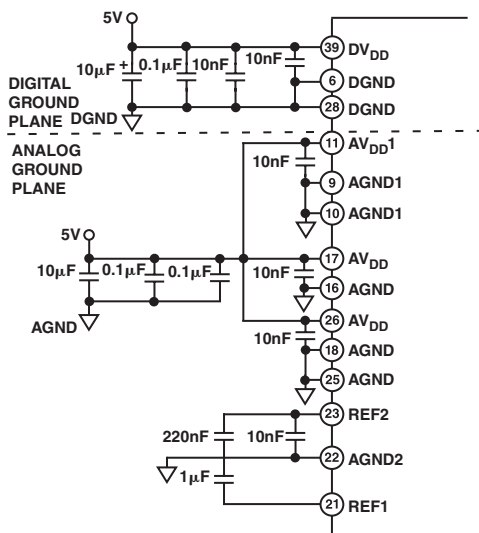

Figure 36. Reference and Supply Decoupling

OPTIMIZING HEAT REMOVAL BY PCB CONSTRUCTION AND DEVICE MOUNTING

For normal still air conditions, the primary heat dissipation path from the chip to the ambient is via the component leads into the PCB. The thermal resistance of the board is then a significant variable. This can be lowered by maximizing the use of ground planes as heat sinks and also by optimizing the way in which the heat can be dissipated, for example conduction into the board mounting chassis. The greater the percentage of copper in the board, especially in the region of the device, the lower the thermal resistance. The use of wide tracks and thermal vias to the ground plane will have a significant effect. Placing critical components close to where the edge of the board is attached to the chassis can provide additional cooling without the use of heat sinks or forced air. Avoid close spacing of high power devices in order to ensure that the heat is dissipated over the maximum possible area.

EVALUATING THE AD7725 PERFORMANCE

There is an AD7725 Evaluation package available that includes a fully assembled tested evaluation board, documentation, and software for controlling the board from a PC via the Evaluation Board Controller. The Evaluation Board Controller can be used in conjunction with the AD7725 Evaluation Board (as well as with many other Analog Devices evaluation boards ending in the CB designator) to demonstrate/evaluate the performance of the AD7725. The software allows the user to perform ac (Fast Fourier Transform) and dc (Histogram of Codes) tests on the AD7725. By downloading the filter design package, Filter Wizard, user-defined filter files can be loaded into the AD7725 to program the postprocessor via the Evaluation Board Controller. See the ADI website for more information.

OUTLINE DIMENSIONS

44-Lead Plastic Quad Flatpack [MQFP] (S-44)

Dimensions shown in millimeters

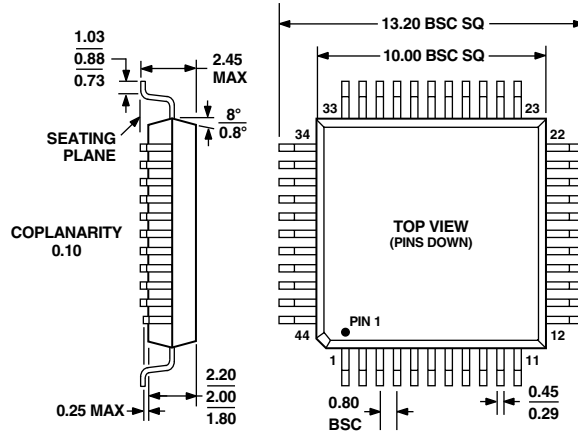

COMPLIANT TO JEDEC STANDARDS MS-022-AB

C01552-0-1/03(0)

PRINTED IN U.S.A.