

AD7870/AD7875/AD7876

FEATURES

Complete Monolithic 12-Bit ADC with:

2 μ s Track/Hold Amplifier

8 μ s A/D Converter

On-Chip Reference

Laser-Trimmed Clock

Parallel, Byte and Serial Digital Interface

72 dB SNR at 10 kHz Input Frequency

(AD7870, AD7875)

57 ns Data Access Time

Low Power: -60 mW typ

Variety of Input Ranges:

± 3 V for AD7870

0 V to +5 V for AD7875

± 10 V for AD7876

GENERAL DESCRIPTION

The AD7870/AD7875/AD7876 is a fast, complete, 12-bit A/D converter. It consists of a track/hold amplifier, 8 μ s successive-approximation ADC, 3 V buried Zener reference and versatile interface logic. The ADC features a self-contained internal clock which is laser trimmed to guarantee accurate control of conversion time. No external clock timing components are required; the on-chip clock may be overridden by an external clock if required.

The parts offer a choice of three data output formats: a single, parallel, 12-bit word; two 8-bit bytes or serial data. Fast bus access times and standard control inputs ensure easy interfacing to modern microprocessors and digital signal processors.

All parts operate from ± 5 V power supplies. The AD7870 and AD7876 accept input signal ranges of ± 3 V and ± 10 V, respectively, while the AD7875 accepts a unipolar 0 V to +5 V input range. The parts can convert full power signals up to 50 kHz.

The AD7870/AD7875/AD7876 feature dc accuracy specifications such as linearity, full-scale and offset error. In addition, the AD7870 and AD7875 are fully specified for dynamic performance parameters including distortion and signal-to-noise ratio.

The parts are available in a 24-pin, 0.3 inch-wide, plastic or hermetic dual-in-line package (DIP). The AD7870 and AD7875 are available in a 28-pin plastic leaded chip carrier (PLCC), while the AD7876 is available and in a 24-pin small outline (SOIC) package.

REV. B

Information furnished by Analog Devices is believed to be accurate and reliable. However, no responsibility is assumed by Analog Devices for its use, nor for any infringements of patents or other rights of third parties which may result from its use. No license is granted by implication or otherwise under any patent or patent rights of Analog Devices.

FUNCTIONAL BLOCK DIAGRAM

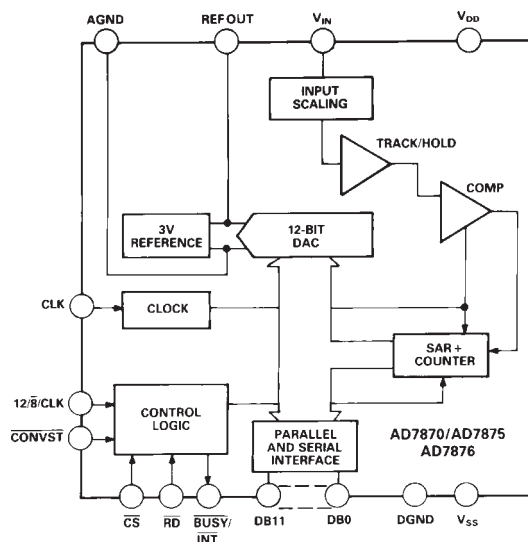

PRODUCT HIGHLIGHTS

1. Complete 12-Bit ADC on a Chip.

The AD7870/AD7875/AD7876 provides all the functions necessary for analog-to-digital conversion and combines a 12-bit ADC with internal clock, track/hold amplifier and reference on a single chip.

2. Dynamic Specifications for DSP Users.

The AD7870 and AD7875 are fully specified and tested for ac parameters, including signal-to-noise ratio, harmonic distortion and intermodulation distortion.

3. Fast Microprocessor Interface.

Data access times of 57 ns make the parts compatible with modern 8- and 16-bit microprocessors and digital signal processors. Key digital timing parameters are tested and guaranteed over the full operating temperature range.

AD7870/AD7875/AD7876—SPECIFICATIONS ($V_{DD} = +5\text{ V} \pm 5\%$, $V_{SS} = -5\text{ V} \pm 5\%$, A6ND = DGND = 0 V, $f_{CLK} = 2.5\text{ MHz}$ external, unless otherwise stated. All Specifications T_{min} to T_{max} unless otherwise noted.)

Parameter	AD7870					Units	Test Conditions/Comments
	J, A ¹	K, B ¹	L, C ¹	S ¹	T ¹		
DYNAMIC PERFORMANCE²							
Signal to Noise Ratio ³ (SNR) @ +25°C	70	70	72	69	69	dB min	$V_{IN} = 10\text{ kHz}$ Sine Wave, $f_{SAMPLE} = 100\text{ kHz}$ Typically 71.5 dB for $0 < V_{IN} < 50\text{ kHz}$
T_{MIN} to T_{MAX}	70	70	71	69	69	dB min	
Total Harmonic Distortion (THD)	-80	-80	-80	-78	-78	dB max	$V_{IN} = 10\text{ kHz}$ Sine Wave, $f_{SAMPLE} = 100\text{ kHz}$ Typically -86 dB for $0 < V_{IN} < 50\text{ kHz}$
Peak Harmonic or Spurious Noise	-80	-80	-80	-78	-78	dB max	$V_{IN} = 10\text{ kHz}$, $f_{SAMPLE} = 100\text{ kHz}$ Typically -86 dB for $0 < V_{IN} < 50\text{ kHz}$
Intermodulation Distortion (IMD)							
Second Order Terms	-80	-80	-80	-78	-78	dB max	$f_a = 9\text{ kHz}$, $f_b = 9.5\text{ kHz}$, $f_{SAMPLE} = 50\text{ kHz}$
Third Order Terms	-80	-80	-80	-78	-78	dB max	$f_a = 9\text{ kHz}$, $f_b = 9.5\text{ kHz}$, $f_{SAMPLE} = 50\text{ kHz}$
Track/Hold Acquisition Time	2	2	2	2	2	μs max	
DC ACCURACY							
Resolution	12	12	12	12	12	Bits	
Minimum Resolution for which No Missing Codes are Guaranteed	12	12	12	12	12	Bits	
Integral Nonlinearity	$\pm 1/2$	$\pm 1/2$	$\pm 1/4$	$\pm 1/2$	$\pm 1/2$	LSB typ	
Integral Nonlinearity		± 1	$\pm 1/2$		± 1	LSB max	
Differential Nonlinearity		± 1	± 1		± 1	LSB max	
Bipolar Zero Error	± 5	± 5	± 5	± 5	± 5	LSB max	
Positive Full-Scale Error ⁴	± 5	± 5	± 5	± 5	± 5	LSB max	
Negative Full-Scale Error ⁴	± 5	± 5	± 5	± 5	± 5	LSB max	
ANALOG INPUT							
Input Voltage Range	± 3	± 3	± 3	± 3	± 3	Volts	
Input Current	± 500	± 500	± 500	± 500	± 500	μA max	
REFERENCE OUTPUT							
REF OUT @ +25°C	2.99 3.01	2.99 3.01	2.99 3.01	2.99 3.01	2.99 3.01	V min V max	
REF OUT Tempco	± 60	± 60	± 35	± 60	± 35	ppm/°C max	
Reference Load Sensitivity ($\Delta\text{REF OUT}/\Delta\text{I}$)	± 1	± 1	± 1	± 1	± 1	mV max	Reference Load Current Change (0–500 μA) Reference Load Should Not Be Changed During Conversion.
LOGIC INPUTS							
Input High Voltage, V_{INH}	2.4	2.4	2.4	2.4	2.4	V min	$V_{DD} = 5\text{ V} \pm 5\%$
Input Low Voltage, V_{INL}	0.8	0.8	0.8	0.8	0.8	V max	$V_{DD} = 5\text{ V} \pm 5\%$
Input Current, I_{IN}	± 10	± 10	± 10	± 10	± 10	μA max	$V_{IN} = 0\text{ V}$ to V_{DD}
Input Current (12/8/CLK Input Only)	± 10	± 10	± 10	± 10	± 10	μA max	$V_{IN} = V_{SS}$ to V_{DD}
Input Capacitance, C_{IN} ⁵	10	10	10	10	10	pF max	
LOGIC OUTPUTS							
Output High Voltage, V_{OH}	4.0	4.0	4.0	4.0	4.0	V min	$I_{SOURCE} = 40\text{ }\mu\text{A}$
Output Low Voltage, V_{OL}	0.4	0.4	0.4	0.4	0.4	V max	$I_{SINK} = 1.6\text{ mA}$
DB11–DB0							
Floating-State Leakage Current	± 10	± 10	± 10	± 10	± 10	μA max	
Floating-State Output Capacitance ⁵	15	15	15	15	15	pF max	
CONVERSION TIME							
External Clock ($f_{CLK} = 2.5\text{ MHz}$)	8	8	8	8	8	μs max	
Internal Clock	7/9	7/9	7/9	7/9	7/9	μs min/ μs max	
POWER REQUIREMENTS							
V_{DD}	+5	+5	+5	+5	+5	V nom	$\pm 5\%$ for Specified Performance
V_{SS}	-5	-5	-5	-5	-5	V nom	$\pm 5\%$ for Specified Performance
I_{DD}	13	13	13	13	13	mA max	Typically 8 mA
I_{SS}	6	6	6	6	6	mA max	Typically 4 mA
Power Dissipation	95	95	95	95	95	mW max	Typically 60 mW

NOTES

¹Temperature ranges are as follows: J, K, L Versions; 0°C to +70°C: A, B, C Versions; -25°C to +85°C: S, T Versions; -55°C to +125°C.

² V_{IN} (pk-pk) = $\pm 3\text{ V}$.

³SNR calculation includes distortion and noise components.

⁴Measured with respect to internal reference and includes bipolar offset error.

⁵Sample tested @ +25°C to ensure compliance.

Specifications subject to change without notice.

Parameter	AD7875/AD7876			Units	Test Conditions/Comments
	K, B ¹	L, C ¹	T ¹		
DC ACCURACY					
Resolution	12	12	12	Bits	
Minimum Resolution for Which No Missing Codes Are Guaranteed	12	12	12	Bits	
Integral Nonlinearity @ +25°C	±1	±1/2	±1	LSB max	
T _{MIN} to T _{MAX} (AD7875 Only)	±1	±1	±1	LSB max	
T _{MIN} to T _{MAX} (AD7876 Only)	±1	±1/2	±1	LSB max	
Differential Nonlinearity	±1	±1	±1.5/-1.0	LSB max	
Unipolar Offset Error (AD7875 Only)	±5	±5	±5	LSB max	
Bipolar Zero Error (AD7876 Only)	±6	±2	±6	LSB max	
Full-Scale Error at +25°C ²	±8	±8	±8	LSB max	Typical Full-Scale Error Is ±1 LSB
Full-Scale TC ²	±60	±35	±60	ppm/°C max	Typical TC is ±20 ppm/°C
Track/Hold Acquisition Time	2	2	2	µs max	
DYNAMIC PERFORMANCE³ (AD7875 ONLY)					
Signal-to-Noise Ratio ⁴ (SNR) @ +25°C	70	72	69	dB min	V _{IN} = 10 kHz Sine Wave, f _{SAMPLE} = 100 kHz Typically 71.5 dB for 0 < V _{IN} < 50 kHz
T _{MIN} to T _{MAX}	70	71	69	dB min	
Total Harmonic Distortion (THD)	-80	-80	-78	dB max	V _{IN} = 10 kHz Sine Wave, f _{SAMPLE} = 100 kHz Typically -86 dB for 0 < V _{IN} < 50 kHz
Peak Harmonic or Spurious Noise	-80	-80	-78	dB max	V _{IN} = 10 kHz, f _{SAMPLE} = 100 kHz Typically -86 dB for 0 < V _{IN} < 50 kHz
Intermodulation Distortion (IMD) Second Order Terms	-80	-80	-78	dB max	f _a = 9 kHz, f _b = 9.5 kHz, f _{SAMPLE} = 50 kHz
Third Order Terms	-80	-80	-78	dB max	f _a = 9 kHz, f _b = 9.5 kHz, f _{SAMPLE} = 50 kHz
ANALOG INPUT					
AD7875 Input Voltage Range	0 to +5	0 to +5	0 to +5	Volts	
AD7875 Input Current	500	500	500	µA max	
AD7876 Input Voltage Range	±10	±10	±10	Volts	
AD7876 Input Current	±600	±600	±600	µA max	
REFERENCE OUTPUT					
REF OUT @ +25°C	2.99	2.99	2.99	V min	
	3.01	3.01	3.01	V max	
REF OUT Tempco	±60	±35	±60	ppm/°C max	Typical Tempco Is ±20 ppm/°C
Reference Load Sensitivity (ΔREF OUT/ΔI)	-1	-1	-1	mV max	Reference Load Current Change (0 µA-500 µA) Reference Load Should Not Be Changed During Conversion.
LOGIC INPUTS					
Input High Voltage, V _{INH}	2.4	2.4	2.4	V min	V _{DD} = 5 V ± 5%
Input Low Voltage, V _{INL}	0.8	0.8	0.8	V max	V _{DD} = 5 V ± 5%
Input Current, I _{IN}	±10	±10	±10	µA max	V _{IN} = 0 V to V _{DD}
Input Current (12/8/CLK Input Only)	±10	±10	±10	µA max	V _{IN} = V _{SS} to V _{DD}
Input Capacitance, C _{IN} ⁵	10	10	10	pF max	
LOGIC OUTPUTS					
Output High Voltage, V _{OH}	4.0	4.0	4.0	V min	I _{SOURCE} = 40 µA
Output Low Voltage, V _{OL}	0.4	0.4	0.4	V max	I _{SINK} = 1.6 mA
DB11-DB0 Floating-State Leakage Current	10	10	10	µA max	
Floating-State Output Capacitance ⁵	15	15	15	pF max	
CONVERSION TIME					
External Clock (f _{CLK} = 2.5 MHz)	8	8	8	µs max	
Internal Clock	7/9	7/9	7/9	µs min/µs max	
POWER REQUIREMENTS					
	As per AD7870				

NOTES

¹Temperature ranges are as follows: AD7875: K, L Versions, 0°C to +70°C; B, C Versions, -40°C to +85°C; T Version, -55°C to +125°C. AD7876: B, C Versions, -40°C to +85°C; T Version, -55°C to +125°C.

²Includes internal reference error and is calculated after unipolar offset error (AD7875) or bipolar zero error (AD7876) has been adjusted out. Full-scale error refers to both positive and negative full-scale error for the AD7876.

³Dynamic performance parameters are not tested on the AD7876 but these are typically the same as for the AD7875.

⁴SNR calculation includes distortion and noise components.

⁵Sample tested @ +25°C to ensure compliance.

Specifications subject to change without notice.

AD7870/AD7875/AD7876

TIMING CHARACTERISTICS^{1, 2} ($V_{DD} = +5\text{ V} \pm 5\%$, $V_{SS} = -5\text{ V} \pm 5\%$, $AGND = DGND = 0\text{ V}$. See Figures 9, 10, 11 and 12.)

Parameter	Limit at T_{MIN} , T_{MAX} (J, K, L, A, B, C Versions)	Limit at T_{MIN} , T_{MAX} (S, T Versions)	Units	Conditions/Comments
t_1	50	50	ns min	\overline{CONVST} Pulse Width
t_2	0	0	ns min	\overline{CS} to \overline{RD} Setup Time (Mode 1)
t_3	60	75	ns min	\overline{RD} Pulse Width
t_4	0	0	ns min	\overline{CS} to \overline{RD} Hold Time (Mode 1)
t_5	70	70	ns max	\overline{RD} to \overline{INT} Delay
t_6^3	57	70	ns max	Data Access Time after \overline{RD}
t_7^4	5	5	ns min	Bus Relinquish Time after \overline{RD}
	50	50	ns max	
t_8	0	0	ns min	HBEN to \overline{RD} Setup Time
t_9	0	0	ns min	HBEN to \overline{RD} Hold Time
t_{10}	100	100	ns min	SSTRB to SCLK Falling Edge Setup Time
t_{11}^5	370	370	ns min	SCLK Cycle Time
t_{12}^6	135	150	ns max	SCLK to Valid Data Delay. $C_L = 35\text{ pF}$
t_{13}	20	20	ns min	SCLK Rising Edge to SSTRB
	100	100	ns max	
t_{14}	10	10	ns min	Bus Relinquish Time after SCLK
	100	100	ns max	
t_{15}	60	60	ns min	\overline{CS} to \overline{RD} Setup Time (Mode 2)
t_{16}	120	120	ns max	\overline{CS} to \overline{BUSY} Propagation Delay
t_{17}	200	200	ns min	Data Setup Time Prior to \overline{BUSY}
t_{18}	0	0	ns min	\overline{CS} to \overline{RD} Hold Time (Mode 2)
t_{19}	0	0	ns min	HBEN to \overline{CS} Setup Time
t_{20}	0	0	ns min	HBEN to \overline{CS} Hold Time

NOTES

¹Timing specifications in **bold print** are 100% production tested. All other times are sample tested at +25°C to ensure compliance. All input signals are specified with $t_r = t_f = 5\text{ ns}$ (10% to 90% of 5 V) and timed from a voltage level of 1.6 V.

²Serial timing is measured with a 4.7 kΩ pull-up resistor on SDATA and SSTRB and a 2 kΩ pull-up on SCLK. The capacitance on all three outputs is 35 pF.

³ t_6 is measured with the load circuits of Figure 1 and defined as the time required for an output to cross 0.8 V or 2.4 V.

⁴ t_7 is defined as the time required for the data lines to change 0.5 V when loaded with the circuits of Figure 2.

⁵SCLK mark/space ratio (measured from a voltage level of 1.6 V) is 40/60 to 60/40.

⁶SDATA will drive higher capacitive loads but this will add to t_{12} since it increases the external RC time constant ($4.7\text{ k}\Omega \parallel C_L$) and hence the time to reach 2.4 V. Specifications subject to change without notice.

ABSOLUTE MAXIMUM RATINGS*

V_{DD} to AGND -0.3 V to +7 V

V_{SS} to AGND +0.3 V to -7 V

AGND to DGND -0.3 V to $V_{DD} + 0.3\text{ V}$

V_{IN} to AGND -15 V to +15 V

REF OUT to AGND 0 V to V_{DD}

Digital Inputs to DGND -0.3 V to $V_{DD} + 0.3\text{ V}$

Digital Outputs to DGND -0.3 V to $V_{DD} + 0.3\text{ V}$

Operating Temperature Range

Commercial (J, K, L Versions - AD7870) ... 0°C to +70°C

Commercial (K, L Versions - AD7875) ... 0°C to +70°C

Industrial (A, B, C Versions - AD7870) ... -25°C to +85°C

Industrial (B, C Versions - AD7875/AD7876) ... -40°C to +85°C

Extended (S, T Versions) ... -55°C to +125°C

Storage Temperature Range -65°C to +150°C

Lead Temperature (Soldering, 10 sec) +300°C

Power Dissipation (Any Package) to +75°C 450 mW

Derates above +75°C by 10 mW/°C

*Stresses above those listed under "Absolute Maximum Ratings" may cause permanent damage to the device. This is a stress rating only; functional operation of the device at these or any other conditions above those listed in the operational sections of this specification is not implied. Exposure to absolute maximum rating conditions for extended periods may affect device reliability.

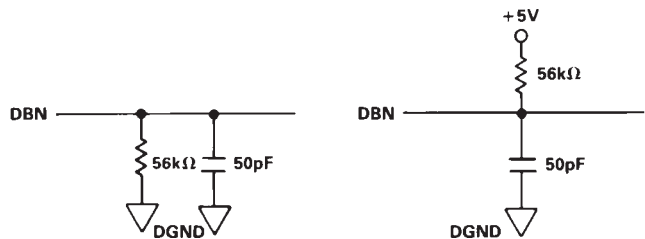

a. High-Z to V_{OH} b. High-Z to V_{OL}
Figure 1. Load Circuits for Access Time

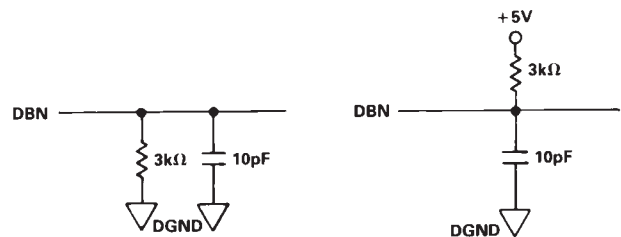

a. V_{OH} to High-Z b. V_{OL} to High-Z
Figure 2. Load Circuits for Output Float Delay

CAUTION

ESD (electrostatic discharge) sensitive device. Electrostatic charges as high as 4000 V readily accumulate on the human body and test equipment and can discharge without detection. Although the AD7870/AD7875/AD7876 feature proprietary ESD protection circuitry, permanent damage may occur on devices subjected to high energy electrostatic discharges. Therefore, proper ESD precautions are recommended to avoid performance degradation or loss of functionality.



AD7870 ORDERING GUIDE

Model ^{1, 2}	Temperature Range	V _{IN} Voltage Range (V)	SNR (dBs)	Integral Nonlinearity (LSB)	Package Option ³
AD7870JN	0°C to +70°C	±3	70 min	±1/2 typ	N-24
AD7870KN	0°C to +70°C	±3	70 min	±1 max	N-24
AD7870LN	0°C to +70°C	±3	72 min	±1/2 max	N-24
AD7870JP	0°C to +70°C	±3	70 min	±1/2 typ	P-28A
AD7870KP	0°C to +70°C	±3	70 min	±1 max	P-28A
AD7870LP	0°C to +70°C	±3	72 min	±1/2 max	P-28A
AD7870AQ	-25°C to +85°C	±3	70 min	±1/2 typ	Q-24
AD7870BQ	-25°C to +85°C	±3	70 min	±1 max	Q-24
AD7870CQ	-25°C to +85°C	±3	72 min	±1/2 max	Q-24
AD7870SQ ⁴	-55°C to +125°C	±3	70 min	±1/2 typ	Q-24
AD7870TQ ⁴	-55°C to +125°C	±3	70 min	±1 max	Q-24

NOTES

¹To order MIL-STD-883, Class B, processed parts, add /883B to part number. Contact local sales office for military data sheet.

²Contact local sales office for LCCC (Leadless Ceramic Chip Carrier) availability.

³N = Narrow Plastic DIP; P = Plastic Leaded Chip Carrier (PLCC); Q = Cerdip.

⁴Available to /883B processing only.

AD7875 ORDERING GUIDE

Model ^{1, 2}	Temperature Range	V _{IN} Voltage Range (V)	SNR (dBs)	Integral Nonlinearity (LSB)	Package Option ³
AD7875KN	0°C to +70°C	0 to +5	70 min	±1 max	N-24
AD7875LN	0°C to +70°C	0 to +5	72 min	±1/2 max	N-24
AD7875KP	0°C to +70°C	0 to +5	70 min	±1 max	P-28A
AD7875LP	0°C to +70°C	0 to +5	72 min	±1/2 max	P-28A
AD7875BQ	-40°C to +85°C	0 to +5	70 min	±1 max	Q-24
AD7875CQ	-40°C to +85°C	0 to +5	72 min	±1/2 max	Q-24
AD7875TQ ⁴	-55°C to +125°C	0 to +5	70 min	±1 max	Q-24

NOTES

¹To order MIL-STD-883, Class B, processed parts, add /883B to part number. Contact local sales office for military data sheet.

²Contact local sales office for LCCC (Leadless Ceramic Chip Carrier) availability.

³N = Narrow Plastic DIP; P = Plastic Leaded Chip Carrier (PLCC); Q = Cerdip.

⁴Available to /883B processing only.

AD7876 ORDERING GUIDE

Model ¹	Temperature Range	V _{IN} Voltage Range (V)	Integral Nonlinearity (LSB)	Package Option ²
AD7876BN	-40°C to +85°C	±10	±1 max	N-24
AD7876CN	-40°C to +85°C	±10	±1/2 max	N-24
AD7876BR	-40°C to +85°C	±10	±1 max	R-24
AD7876CR	-40°C to +85°C	±10	±1/2 max	R-24
AD7876BQ	-40°C to +85°C	±10	±1 max	Q-24
AD7876CQ	-40°C to +85°C	±10	±1/2 max	Q-24
AD7876TQ ³	-55°C to +125°C	±10	±1 max	Q-24

NOTES

¹To order MIL-STD-883, Class B, processed parts, add /883B to the part number. Contact local sales office for military data sheet.

²N = Narrow Plastic DIP; Q = Cerdip; R = Small Outline IC (SOIC).

³Available to /883B processing only.

AD7870/AD7875/AD7876

PIN FUNCTION DESCRIPTION

DIP Pin No.	Pin Mnemonic	Function
1	\overline{RD}	Read. Active low logic input. This input is used in conjunction with \overline{CS} low to enable the data outputs.
2	$\overline{BUSY}/\overline{INT}$	Busy/Interrupt, Active low logic output indicating converter status. See timing diagrams.
3	CLK	Clock input. An external TTL-compatible clock may be applied to this input pin. Alternatively, tying this pin to V_{SS} enables the internal laser-trimmed clock oscillator.
4	DB11/HBEN	Data Bit 11 (MSB)/High Byte Enable. The function of this pin is dependent on the state of the $12/\overline{8}/\text{CLK}$ input (see below). When 12-bit parallel data is selected, this pin provides the DB11 output. When byte data is selected, this pin becomes the HBEN logic input HBEN is used for 8-bit bus interfacing. When HBEN is low, DB7/LOW to DB0/DB8 become DB7 to DB0. With HBEN high, DB7/LOW to DB0/DB8 are used for the upper byte of data (see Table I).
5	DB10/ \overline{SSTRB}	Data Bit 10/Serial Strobe. When 12-bit parallel data is selected, this pin provides the DB10 output. \overline{SSTRB} is an active low open-drain output that provides a strobe or framing pulse for serial data. An external 4.7 k Ω pull-up resistor is required on \overline{SSTRB} .
6	DB9/SCLK	Data Bit 9/Serial Clock. When 12-bit parallel data is selected, this pin provides the DB9 output. SCLK is the gated serial clock output derived from the internal or external ADC clock. If the $12/\overline{8}/\text{CLK}$ input is at -5 V, then SCLK runs continuously. If $12/\overline{8}/\text{CLK}$ is at 0 V, then SCLK is gated off after serial transmission is complete. SCLK is an open-drain output and requires an external 2 k Ω pull-up resistor.
7	DB8/SDATA	Data Bit 8/Serial Data. When 12-bit parallel data is selected, this pin provides the DB8 output. SDATA is an open-drain serial data output which is used with SCLK and \overline{SSTRB} for serial data transfer. Serial data is valid on the falling edge of SCLK while \overline{SSTRB} is low. An external 4.7 k Ω pull-up resistor is required on SDATA.
8-11	DB7/LOW-DB4/LOW	Three-state data outputs controlled by \overline{CS} and \overline{RD} . Their function depends on the $12/\overline{8}/\text{CLK}$ and HBEN inputs. With $12/\overline{8}/\text{CLK}$ high, they are always DB7-DB4. With $12/\overline{8}/\text{CLK}$ low or -5 V, their function is controlled by HBEN (see Table I).
12	DGND	Digital Ground. Ground reference for digital circuitry.
13-16	DB3/DB11-DB0/DB8	Three-state data outputs which are controlled by \overline{CS} and \overline{RD} . Their function depends on the $12/\overline{8}/\text{CLK}$ and HBEN inputs. With $12/\overline{8}/\text{CLK}$ high, they are always DB3-DB0. With $12/\overline{8}/\text{CLK}$ low or -5 V, their function is controlled by HBEN (see Table I).

Table I. Output Data for Byte Interfacing

HBEN	DB7/LOW	DB6/LOW	DB5/LOW	DB4/LOW	DB3/DB11	DB2/DB10	DB1/DB9	DB0/DB8
HIGH	LOW	LOW	LOW	LOW	DB11(MSB)	DB10	DB9	DB8
LOW	DB7	DB6	DB5	DB4	DB3	DB2	DB1	DB0 (LSB)

17	V_{DD}	Positive Supply, +5 V \pm 5%.
18	AGND	Analog Ground. Ground reference for track/hold, reference and DAC.
19	REF OUT	Voltage Reference Output. The internal 3 V reference is provided at this pin. The external load capability is 500 μA .
20	V_{IN}	Analog Input. The analog input range is ± 3 V for the AD7870, ± 10 V for the AD7876 and 0 V to +5 V for the AD7875.
21	V_{SS}	Negative Supply, -5 V \pm 5%.
22	$12/\overline{8}/\text{CLK}$	Three Function Input. Defines the data format and serial clock format. With this pin at +5 V, the output data format is 12-bit parallel only. With this pin at 0 V, either byte or serial data is available and SCLK is not continuous. With this pin at -5 V, either byte or serial data is again available but SCLK is now continuous.
23	$\overline{\text{CONVST}}$	Convert Start. A low to high transition on this input puts the track/hold into its hold mode and starts conversion. This input is asynchronous to the CLK input.
24	$\overline{\text{CS}}$	Chip Select. Active low logic input. The device is selected when this input is active. With $\overline{\text{CONVST}}$ tied low, a new conversion is initiated when $\overline{\text{CS}}$ goes low.

PIN CONFIGURATIONS¹

DIP and SOIC²

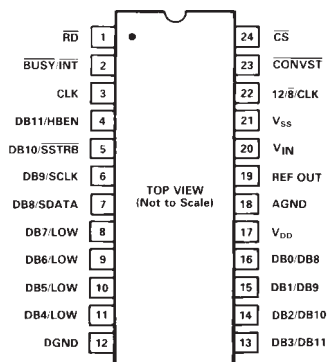

PLCC²

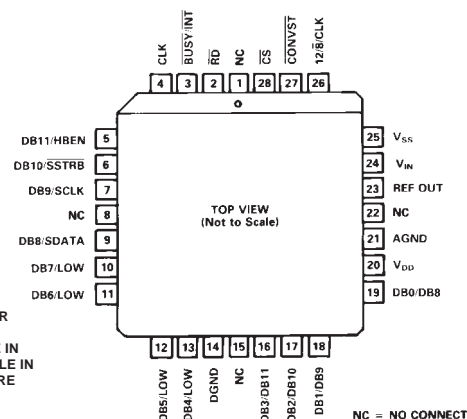

¹PIN CONFIGURATIONS ARE THE SAME FOR THE AD7875 AND AD7876.
²THE AD7870 AND AD7875 ARE AVAILABLE IN DIP AND PLCC; THE AD7870A IS AVAILABLE IN PLASTIC DIP; THE AD7875 AND AD7876 ARE AVAILABLE IN SOIC AND DIP.

CONVERTER DETAILS

The AD7870/AD7875/AD7876 is a complete 12-bit A/D converter, requiring no external components apart from power supply decoupling capacitors. It is comprised of a 12-bit successive approximation ADC based on a fast settling voltage output DAC, a high speed comparator and SAR, a track/hold amplifier, a 3 V buried Zener reference, a clock oscillator and control logic.

INTERNAL REFERENCE

The AD7870/AD7875/AD7876 has an on-chip temperature compensated buried Zener reference that is factory trimmed to $3\text{ V} \pm 10\text{ mV}$. Internally it provides both the DAC reference and the dc bias required for bipolar operation (AD7870 and AD7876). The reference output is available (REF OUT) and capable of providing up to $500\text{ }\mu\text{A}$ to an external load.

The maximum recommended capacitance on REF OUT for normal operation is 50 pF . If the reference is required for use external to the ADC, it should be decoupled with a $200\text{ }\Omega$ resistor in series with a parallel combination of a $10\text{ }\mu\text{F}$ tantalum capacitor and a $0.1\text{ }\mu\text{F}$ ceramic capacitor. These decoupling components are required to remove voltage spikes caused by the ADC's internal operation.

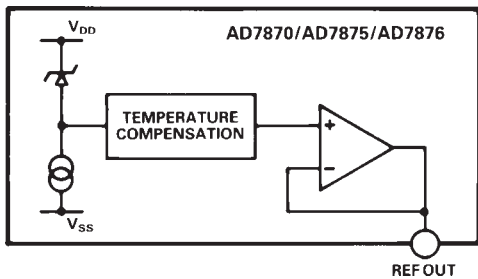

Figure 3. Reference Circuit

The reference output voltage is 3 V. For applications using the AD7875 or AD7876, a 5 V or 10 V reference may be required. Figure 4 shows how to scale the 3 V REF OUT voltage to provide either a 5 V or 10 V external reference.

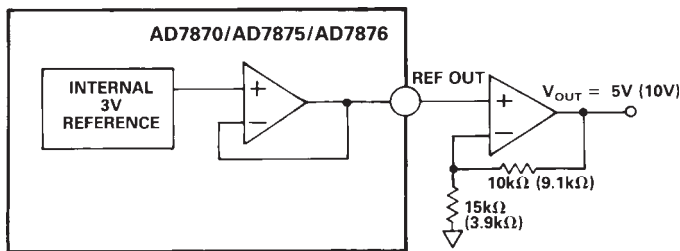

Figure 4. Generating a 5 V or 10 V Reference

TRACK-AND-HOLD AMPLIFIER

The track-and-hold amplifier on the analog input of the AD7870/AD7875/AD7876 allows the ADC to accurately convert input frequencies to 12-bit accuracy. The input bandwidth of the track/hold amplifier is much greater than the Nyquist rate of the ADC even when the ADC is operated at its maximum throughput rate. The 0.1 dB cutoff frequency occurs typically at 500 kHz. The track/hold amplifier acquires an input signal to 12-bit accuracy in less than $2\text{ }\mu\text{s}$. The overall throughput rate is equal

to the conversion time plus the track/hold amplifier acquisition time. For a 2.5 MHz input clock the throughput rate is $10\text{ }\mu\text{s}$ max.

The operation of the track/hold is essentially transparent to the user. The track/hold amplifier goes from its tracking mode to its hold mode at the start of conversion. If the $\overline{\text{CONVST}}$ input is used to start conversion then the track to hold transition occurs on the rising edge of $\overline{\text{CONVST}}$. If $\overline{\text{CS}}$ starts conversion, this transition occurs on the falling edge of $\overline{\text{CS}}$.

ANALOG INPUT

The three parts differ from each other in the analog input voltage range that they can handle. The AD7870 accepts $\pm 3\text{ V}$ input signals, the AD7876 accepts a $\pm 10\text{ V}$ input range, while the input range for the AD7875 is 0 V to $+5\text{ V}$.

Figure 5a shows the AD7870 analog input. The analog input range is $\pm 3\text{ V}$ into an input resistance of typically $15\text{ k}\Omega$. The designed code transitions occur midway between successive integer LSB values (i.e., $1/2\text{ LSB}$, $3/2\text{ LSBs}$, $5/2\text{ LSBs}$. . . $\text{FS}-3/2\text{ LSBs}$). The output code is two's complement binary with $1\text{ LSB} = \text{FS}/4096 = 6\text{ V}/4096 = 1.46\text{ mV}$. The ideal input/output transfer function is shown in Figure 6.

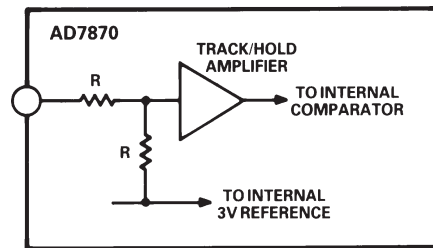

Figure 5a. AD7870 Analog Input

The AD7876 analog input structure is shown in Figure 5b. The analog input range is $\pm 10\text{ V}$ into an input resistance of typically $33\text{ k}\Omega$. As before, the designed code transitions occur midway between successive integer LSB values. The output code is 2's complement with $1\text{ LSB} = \text{FS}/4096 = 20\text{ V}/4096 = 4.88\text{ mV}$. The ideal input/output transfer function is shown in Figure 6.

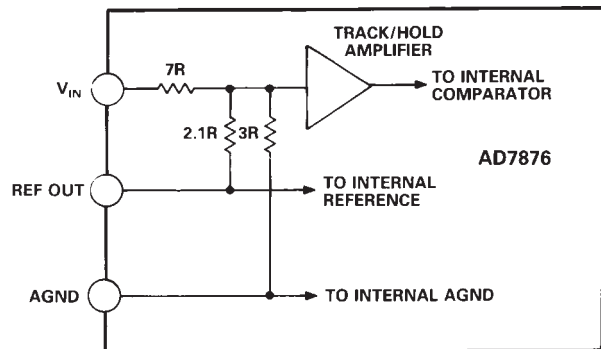

Figure 5b. AD7876 Analog Input

Figure 5c shows the analog input for the AD7875. The input range is 0 V to $+5\text{ V}$ into an input resistance of typically $25\text{ k}\Omega$. Once again, the designed code transitions occur midway between successive integer LSB values. The output code is

AD7870/AD7875/AD7876

straight binary with $1 \text{ LSB} = \text{FS}/4096 = 5 \text{ V}/4096 = 1.22 \text{ mV}$. The ideal input/output transfer function is shown in Figure 7.

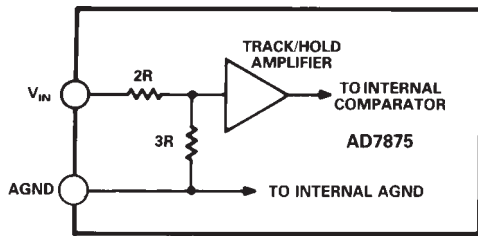

Figure 5c. AD7875 Analog Input

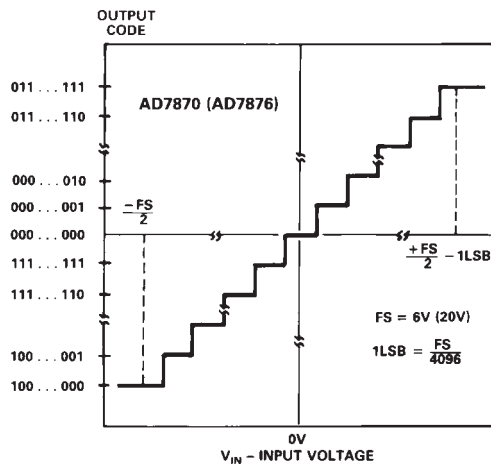

Figure 6. AD7870/AD7876 Transfer Function

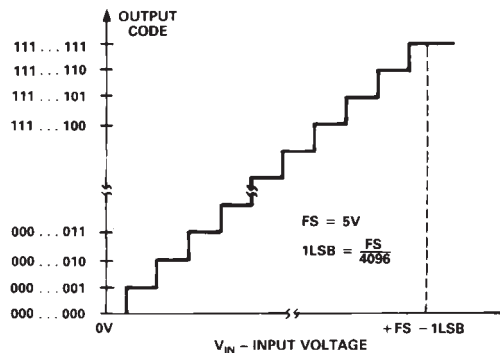

Figure 7. AD7875 Transfer Function

OFFSET AND FULL-SCALE ADJUSTMENT—AD7870

In most digital signal processing (DSP) applications, offset and full-scale errors have little or no effect on system performance. Offset error can always be eliminated in the analog domain by ac coupling. Full-scale error effect is linear and does not cause problems as long as the input signal is within the full dynamic range of the ADC. Some applications will require that the input signal span the full analog input dynamic range. In such applications, offset and full-scale error will have to be adjusted to zero.

Where adjustment is required, offset error must be adjusted before full-scale error. This is achieved by trimming the offset of the op amp driving the analog input of the AD7870 while the

input voltage is $1/2 \text{ LSB}$ below ground. The trim procedure is as follows: apply a voltage of -0.73 mV ($-1/2 \text{ LSB}$) at V_1 in Figure 8 and adjust the op amp offset voltage until the ADC output code flickers between 1111 1111 1111 and 0000 0000 0000. Gain error can be adjusted at either the first code transition (ADC negative full-scale) or the last code transition (ADC positive full scale). The trim procedures for both cases are as follows (see Figure 8).

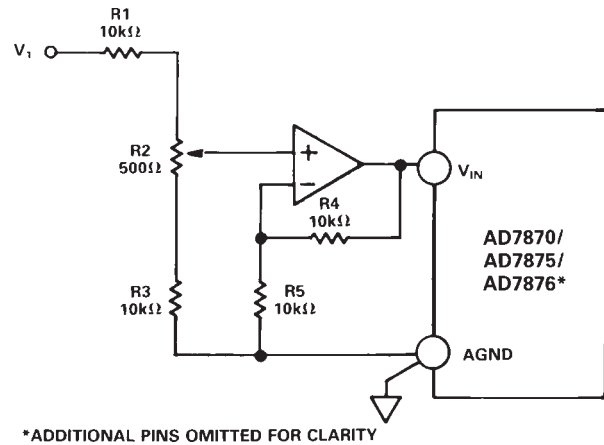

*ADDITIONAL PINS OMITTED FOR CLARITY

Figure 8. Offset and Full-Scale Adjust Circuit

Positive Full-Scale Adjust

Apply a voltage of 2.9978 V ($\text{FS}/2 - 3/2 \text{ LSBs}$) at V_1 . Adjust R2 until the ADC output code flickers between 0111 1111 1110 and 0111 1111 1111.

Negative Full-Scale Adjust

Apply a voltage of -2.9993 V ($-\text{FS}/2 + 1/2 \text{ LSB}$) at V_1 and adjust R2 until the ADC output code flickers between 1000 0000 0000 and 1000 0000 0001.

OFFSET AND FULL-SCALE ADJUSTMENT—AD7876

The offset and full-scale adjustment for the AD7876 is similar to that just outlined for the AD7870. The trim procedure, for those applications that do require adjustment, is as follows: apply a voltage of -2.44 mV ($-1/2 \text{ LSB}$) at V_1 and adjust the op amp offset voltage until the ADC output code flickers between 1111 1111 1111 and 0000 0000 0000. Full-scale error can be adjusted at either the first code transition (ADC negative full scale) or the last code transition (ADC positive full scale). The trim procedure for both case is as follows (see Figure 8):

Positive Full-Scale Adjust

Apply a voltage of 9.9927 V ($\text{FS}/2 - 3/2 \text{ LSBs}$) at V_1 . Adjust R2 until the ADC output code flickers between 0111 1111 1110 and 0111 1111 1111.

Negative Full-Scale Adjust

Apply a voltage of -9.9976 V ($\text{FS}/2 + 1/2 \text{ LSB}$) at V_1 and adjust R2 until the ADC output code flickers between 1000 0000 0000 and 1000 0000 0001.

OFFSET AND FULL-SCALE ADJUSTMENT—AD7875

Similar to the AD7870, most of the DSP applications in which the AD7875 will be used will not require offset and full-scale adjustment. For applications that do require adjustment, offset error must be adjusted before full-scale (gain) error. This is achieved by applying an input voltage of 0.61 mV (1/2 LSB) to V_1 in Figure 8 and adjusting the op amp offset voltage until the ADC output code flickers between 0000 0000 0000 and 0000 0000 0001. For full-scale adjustment, apply an input voltage of 4.9982 V (FS – 3/2 LSBs) to V_1 and adjust R2 until the ADC output code flickers between 1111 1111 1110 and 1111 1111 1111.

TIMING AND CONTROL

The AD7870/AD7875/AD7876 is capable of two basic operating modes. In the first mode (Mode 1), the $\overline{\text{CONVST}}$ line is used to start conversion and drive the track/hold into its hold mode. At the end of conversion the track/hold returns to its tracking mode. It is intended principally for digital signal processing and other applications where precise sampling in time is required. In these applications, it is important that the signal sampling occurs at exactly equal intervals to minimize errors due to sampling uncertainty or jitter. For these cases, the $\overline{\text{CONVST}}$ line is driven by a timer or some precise clock source.

The second mode is achieved by hard-wiring the $\overline{\text{CONVST}}$ line low. This mode (Mode 2) is intended for use in systems where the microprocessor has total control of the ADC, both initiating the conversion and reading the data. $\overline{\text{CS}}$ starts conversion and the microprocessor will normally be driven into a WAIT state for the duration of conversion by $\overline{\text{BUSY/INT}}$.

DATA OUTPUT FORMATS

In addition to the two operating modes, the AD7870/AD7875/AD7876 also offers a choice of three data output formats, one serial and two parallel. The parallel data formats are a single, 12-bit parallel word for 16-bit data buses and a two-byte format for 8-bit data buses. The data format is controlled by the 12/8/CLK input. A logic high on this pin selects the 12-bit parallel output format only. A logic low or –5 V applied to this pin allows the user access to either serial or byte formatted data. Three of the pins previously assigned to the four MSBs in parallel form are now used for serial communications while the fourth pin becomes a control input for the byte-formatted data. The three possible data output formats can be selected in either of the modes of operation.

Parallel Output Format

The two parallel formats available on the part are a 12-bit wide data word and a two-byte data word. In the first, all 12 bits of data are available at the same time on DB11 (MSB) through DB0 (LSB). In the second, two reads are required to access the data. When this data format is selected, the DB11/HBEN pin assumes the HBEN function. HBEN selects which byte of data is to be read from the ADC. When HBEN is low, the lower eight bits of data are placed on the data bus during a read operation; with HBEN high, the upper four bits of the 12-bit word are placed on the data bus. These four bits are right justified and thereby occupy the lower nibble of data while the upper nibble contains four zeros.

Serial Output Format

Serial data is available on the AD7870/AD7875/AD7876 when the 12/8/CLK input is at 0 V or –5 V and in this case the DB10/ $\overline{\text{SSTRB}}$, DB9/SCLK and DB8/SDATA pins assume their serial

functions. Serial data is available during conversion with a word length of 16 bits; four leading zeros, followed by the 12-bit conversion result starting with the MSB. The data is synchronized to the serial clock output (SCLK) and framed by the serial strobe ($\overline{\text{SSTRB}}$). Data is clocked out on a low to high transition of the serial clock and is valid on the falling edge of this clock while the $\overline{\text{SSTRB}}$ output is low. $\overline{\text{SSTRB}}$ goes low within three clock cycles after $\overline{\text{CONVST}}$, and the first serial data bit (the first leading zero) is valid on the first falling edge of SCLK. All three serial lines are open-drain outputs and require external pull-up resistors.

The serial clock out is derived from the ADC clock source, which may be internal or external. Normally, SCLK is required during the serial transmission only. In these cases, it can be shut down at the end of conversion to allow multiple ADCs to share a common serial bus. However, some serial systems (e.g., TMS32020) require a serial clock that runs continuously. Both options are available on the AD7870/AD7875/AD7876 using the 12/8/CLK input. With this input at –5 V, the serial clock (SCLK) runs continuously; when 12/8/CLK is at 0 V, SCLK is turned off at the end of transmission.

MODE 1 INTERFACE

Conversion is initiated by a low going pulse on the $\overline{\text{CONVST}}$ input. The rising edge of this $\overline{\text{CONVST}}$ pulse starts conversion and drives the track/hold amplifier into its hold mode. Conversion will not be initiated if the $\overline{\text{CS}}$ is low. The $\overline{\text{BUSY/INT}}$ status output assumes its $\overline{\text{INT}}$ function in this mode. $\overline{\text{INT}}$ is normally high and goes low at the end of conversion. This $\overline{\text{INT}}$ line can be used to interrupt the microprocessor. A read operation to the ADC accesses the data and the $\overline{\text{INT}}$ line is reset high on the falling edge of $\overline{\text{CS}}$ and $\overline{\text{RD}}$. The $\overline{\text{CONVST}}$ input must be high when $\overline{\text{CS}}$ and $\overline{\text{RD}}$ are brought low for the ADC to operate correctly in this mode. The $\overline{\text{CS}}$ or $\overline{\text{RD}}$ input should not be hard-wired low in this mode. Data cannot be read from the part during conversion because the on-chip latches are disabled when conversion is in progress. In applications where precise sampling is not critical, the $\overline{\text{CONVST}}$ pulse can be generated from a microprocessor $\overline{\text{WR}}$ line OR-gated with a decoded address. In some applications, depending on power supply turn-on time, the AD7870/AD7875/AD7876 may perform a conversion on power-up. In this case, the $\overline{\text{INT}}$ line will power-up low and a dummy read to the AD7870/AD7875/AD7876 will be required to reset the $\overline{\text{INT}}$ line before starting conversion.

Figure 9 shows the Mode 1 timing diagram for a 12-bit parallel data output format (12/8/CLK = +5 V). A read to the ADC at the end of conversion accesses all 12 bits of data at the same time. Serial data is not available for this data output format.

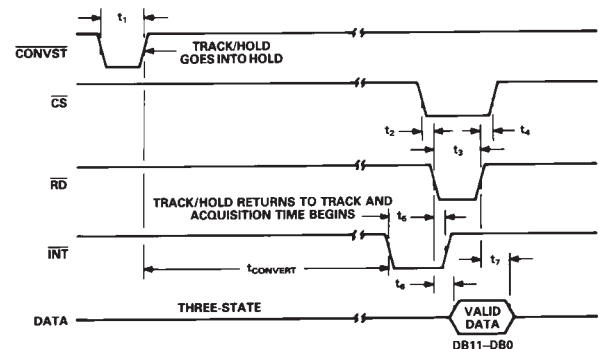

Figure 9. Mode 1 Timing Diagram, 12-Bit Parallel Read

AD7870/AD7875/AD7876

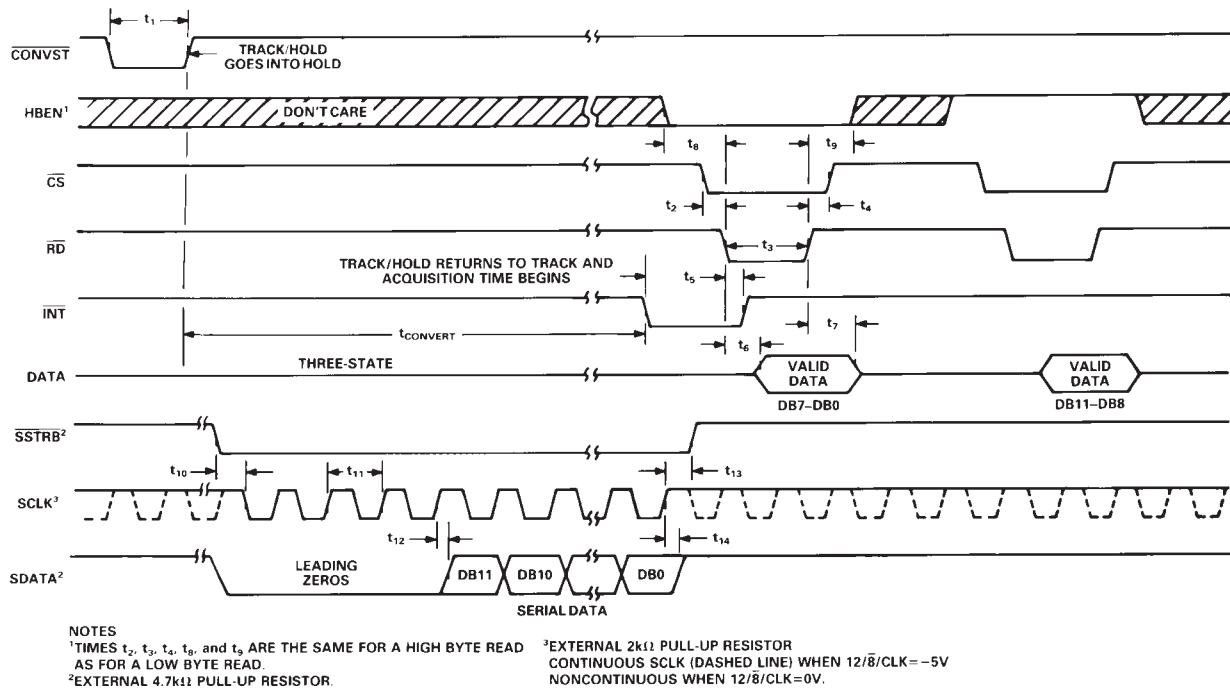

Figure 10. Mode 1 Timing Diagram, Byte or Serial Read

The Mode 1 timing diagram for byte and serial data is shown in Figure 10. \overline{INT} goes low at the end of conversion and is reset high by the first falling edge of \overline{CS} and \overline{RD} . This first read at the end of conversion can either access the low byte or high byte of data depending on the status of \overline{HBEN} (Figure 10 shows low byte only for example). The diagram shows both a noncontinuously and a continuously running clock (dashed line).

MODE 2 INTERFACE

The second interface mode is achieved by hard wiring \overline{CONVST} low and conversion is initiated by taking \overline{CS} low while \overline{HBEN} is low. The track/hold amplifier goes into the hold mode on the falling edge of \overline{CS} . In this mode, the $\overline{BUSY}/\overline{INT}$ pin assumes

its \overline{BUSY} function. \overline{BUSY} goes low at the start of conversion, stays low during the conversion and returns high when the conversion is complete. It is normally used in parallel interfaces to drive the microprocessor into a WAIT state for the duration of conversion.

Figure 11 shows the Mode 2 timing diagram for the 12-bit parallel data output format (12 \bar{S} /CLK = +5 V). In this case, the ADC behaves like slow memory. The major advantage of this interface is that it allows the microprocessor to start conversion, WAIT and then read data with a single READ instruction. The user does not have to worry about servicing interrupts or ensuring that software delays are long enough to avoid reading during conversion.

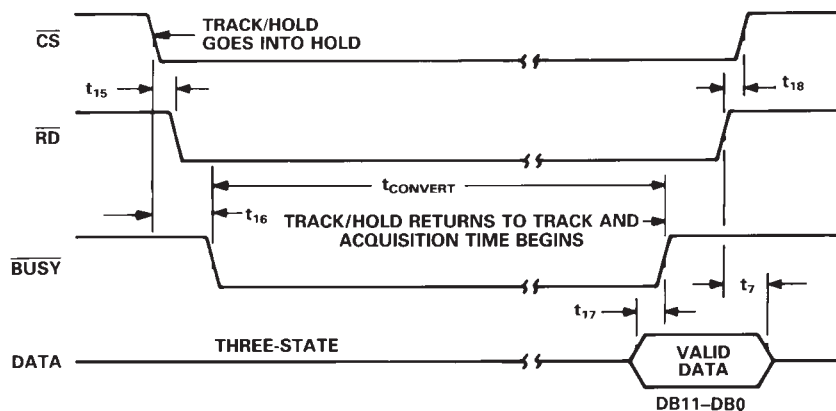

Figure 11. Mode 2 Timing Diagram, 12-Bit Parallel Read

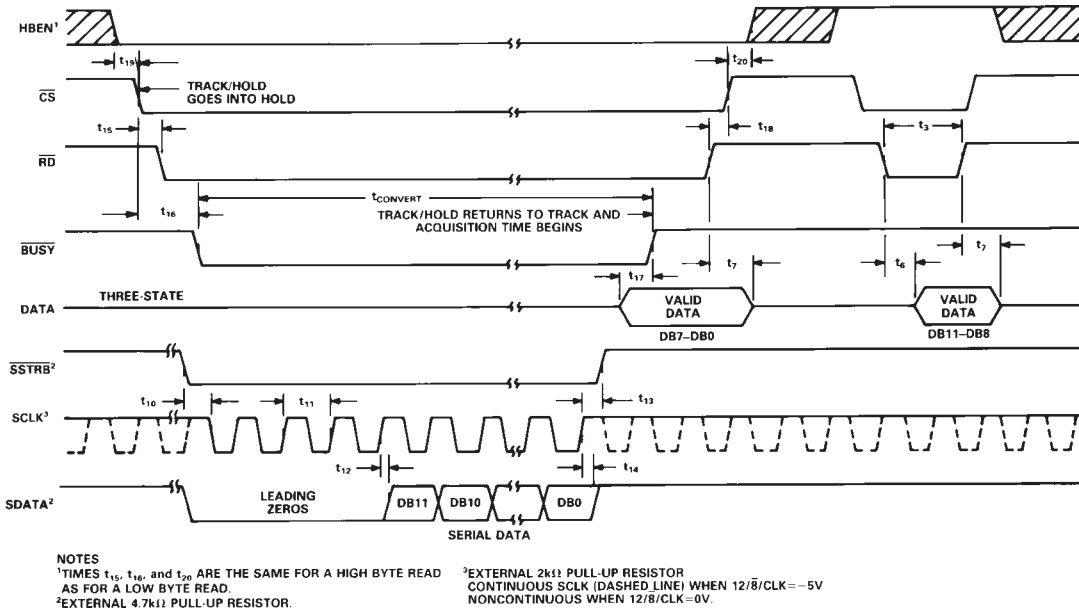

Figure 12. Mode 2 Timing Diagram, Byte or Serial Read

The Mode 2 timing diagram for byte and serial data is shown in Figure 12. For two-byte data read, the lower byte (DB0-DB7) has to be accessed first because HBEN must be low to start conversion. The ADC behaves like slow memory for this first read, but the second read to access the upper byte of data is a normal read. Operation of the serial functions is identical between Mode 1 and Mode 2. The timing diagram of Figure 12 shows both a noncontinuously and a continuously running SCLK (dashed line).

DYNAMIC SPECIFICATIONS

The AD7870 and AD7875 are specified and 100% tested for dynamic performance specifications as well as traditional dc specifications such as integral and differential nonlinearity. Although the AD7876 is not production tested for ac parameters, its dynamic performance is similar to the AD7870 and AD7875. The ac specifications are required for signal processing applications such as speech recognition, spectrum analysis and high speed modems. These applications require information on the ADC's effect on the spectral content of the input signal. Hence, the parameters for which the AD7870 and AD7875 are specified include SNR, harmonic distortion, intermodulation distortion and peak harmonics. These terms are discussed in more detail in the following sections.

Signal-to-Noise Ratio (SNR)

SNR is the measured signal-to-noise ratio at the output of the ADC. The signal is the rms magnitude of the fundamental. Noise is the rms sum of all the nonfundamental signals up to half the sampling frequency (FS/2) excluding dc. SNR is dependent upon the number of quantization levels used in the digitization process; the more levels, the smaller the quantization noise. The theoretical signal-to-noise ratio for a sine wave input is given by

$$SNR = (6.02N + 1.76) \text{ dB} \tag{1}$$

where N is the number of bits. Thus for an ideal 12-bit converter, $SNR = 74 \text{ dB}$.

sine-wave signal of very low distortion to the V_{IN} input which is sampled at a 100 kHz sampling rate. A Fast Fourier Transform (FFT) plot is generated from which the SNR data can be obtained. Figure 13 shows a typical 2048 point FFT plot of the AD7870KN/AD7875KN with an input signal of 25 kHz and a sampling frequency of 100 kHz. The SNR obtained from this graph is 72.6 dB. It should be noted that the harmonics are taken into account when calculating the SNR.

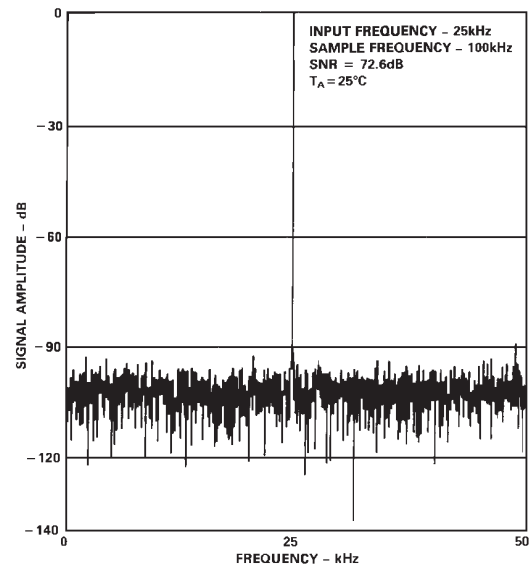

Figure 13. FFT Plot

Effective Number of Bits

The formula given in (1) relates SNR to the number of bits. Rewriting the formula, as in (2), it is possible to get a measure of performance expressed in effective number of bits (N).

$$N = \frac{SNR - 1.76}{6.02} \tag{2}$$

The effective number of bits for a device can be calculated directly from its measured SNR.

AD7870/AD7875/AD7876

Figure 14 shows a typical plot of effective number of bits versus frequency for an AD7870KN/AD7875KN with a sampling frequency of 100 kHz. The effective number of bits typically falls between 11.7 and 11.85 corresponding to SNR figures of 72.2 and 73.1 dB.

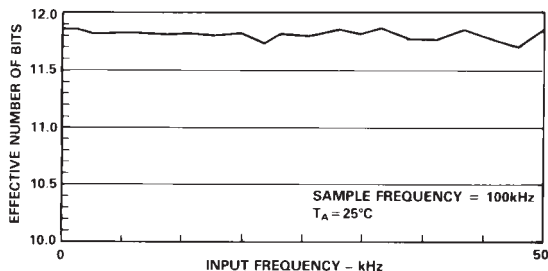

Figure 14. Effective Number of Bits vs. Frequency

Total Harmonic Distortion (THD)

THD is the ratio of the rms sum of harmonics to the rms value of the fundamental. For the AD7870/AD7875, THD is defined as

$$THD = 20 \log \frac{\sqrt{V_2^2 + V_3^2 + V_4^2 + V_5^2 + V_6^2}}{V_1}$$

where V_1 is the rms amplitude of the fundamental and V_2, V_3, V_4, V_5 and V_6 are the rms amplitudes of the second through the sixth harmonic. The THD is also derived from the FFT plot of the ADC output spectrum.

Intermodulation Distortion

With inputs consisting of sine waves at two frequencies, f_a and f_b , any active device with nonlinearities will create distortion products at sum and difference frequencies of $m f_a \pm n f_b$ where $m, n = 0, 1, 2, 3$, etc. Intermodulation terms are those for which neither m nor n are equal to zero. For example, the second order terms include $(f_a + f_b)$ and $(f_a - f_b)$, while the third order terms include $(2f_a + f_b)$, $(2f_a - f_b)$, $(f_a + 2f_b)$ and $(f_a - 2f_b)$.

Using the CCIF standard, where two input frequencies near the top end of the input bandwidth are used, the second and third order terms are of different significance. The second order terms are usually distanced in frequency from the original sine waves while the third order terms are usually at a frequency close to the input frequencies. As a result, the second and third order terms are specified separately. The calculation of the intermodulation distortion is as per the THD specification where it is the ratio of the rms sum of the individual distortion products to the rms amplitude of the fundamental expressed in dBs. In this case, the input consists of two, equal amplitude, low distortion sine waves. Figure 15 shows a typical IMD plot for the AD7870/AD7875.

Peak Harmonic or Spurious Noise

Peak harmonic or spurious noise is defined as the ratio of the rms value of the next largest component in the ADC output spectrum (up to $FS/2$ and excluding dc) to the rms value of the fundamental. Normally, the value of this specification will be determined by the largest harmonic in the spectrum, but for parts where the harmonics are buried in the noise floor the peak will be a noise peak.

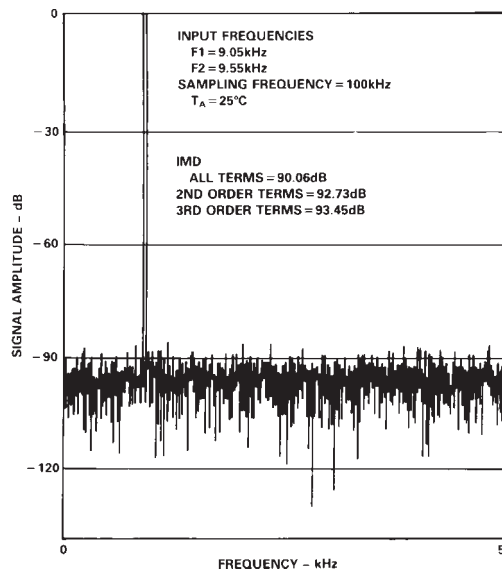

Figure 15. IMD Plot

AC Linearity Plot

When a sine wave of specified frequency is applied to the V_{IN} input of the AD7870/AD7875 and several million samples are taken, a histogram showing the frequency of occurrence of each of the 4096 ADC codes can be generated. From this histogram data it is possible to generate an ac integral linearity plot as shown in Figure 16. This shows very good integral linearity performance from the AD7870/AD7875 at an input frequency of 25 kHz. The absence of large spikes in the plot shows good differential linearity. Simplified versions of the formulae used are outlined below.

$$INL(i) = \left[\frac{V(i) - V(o)}{V(f_s) - V(o)} \cdot 4096 \right] - i$$

where $INL(i)$ is the integral linearity at code i . $V(f_s)$ and $V(o)$ are the estimated full-scale and offset transitions and $V(i)$ is the estimated transition for the i^{th} code.

$V(i)$ the estimated code transition point is derived as follows:

$$V(i) = -A \cdot \cos \left[\frac{\pi \cdot cum(i)}{N} \right]$$

where A is the peak signal amplitude,

N is the number of histogram samples

and $cum(i) = \sum_{n=0}^i V(n)$ occurrences

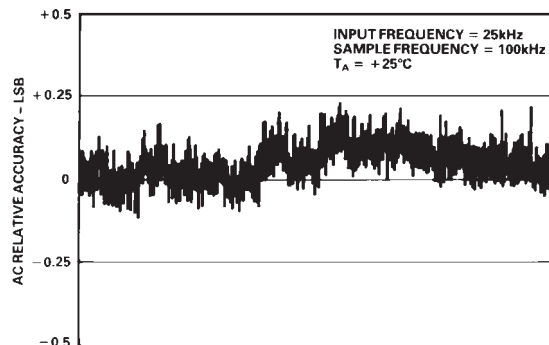

Figure 16. AC INL Plot

MICROPROCESSOR INTERFACE

The AD7870/AD7875/AD7876 has a wide variety of interfacing options. It offers two operating modes and three data-output formats. Fast data access times allow direct interfacing to most microprocessors including the DSP processors.

Parallel Read Interfacing

Figures 17 to 19 show interfaces to the ADSP-2100, TMS32010 and the TMS32020 DSP processors. The ADC is operating in Mode 1, parallel read for all three interfaces. An external timer controls conversion start asynchronously to the microprocessor. At the end of each conversion the ADC $\overline{\text{BUSY}}/\overline{\text{INT}}$ interrupts the microprocessor. The conversion result is read from the ADC with the following instruction:

ADSP-2100: MR0 = DM(ADC)

TMS32010: IN D,ADC

TMS32020: IN D,ADC

MR0 = ADSP-2100 MR0 Register

D = Data Memory Address

ADC = AD7870/AD7875/AD7876 Address

Some applications may require that conversions be initiated by the microprocessor rather than an external timer. One option is to decode the $\overline{\text{CONVST}}$ signal from the address bus so that a write operation to the ADC starts a conversion. Data is read at the end of conversion as described earlier. Note: a read operation must not be attempted during conversion.

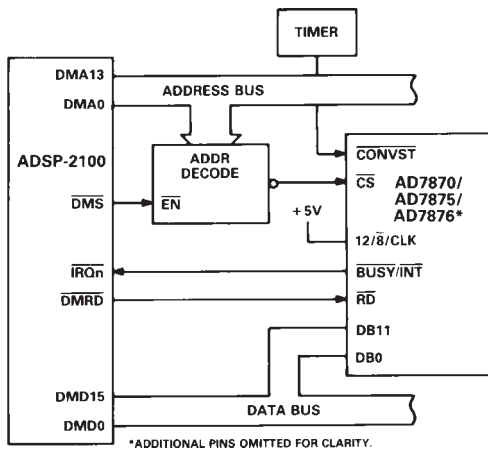

Figure 17. ADSP-2100 Parallel Interface

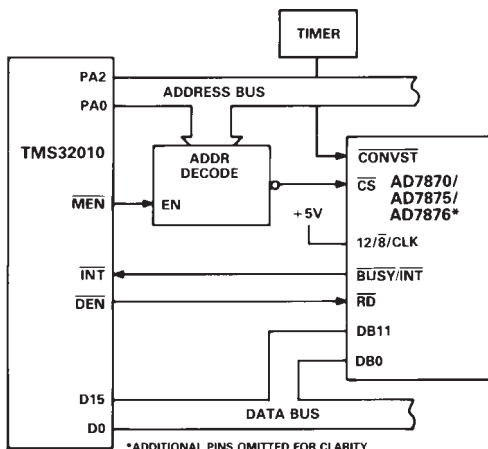

Figure 18. TMS32010 Parallel Interface

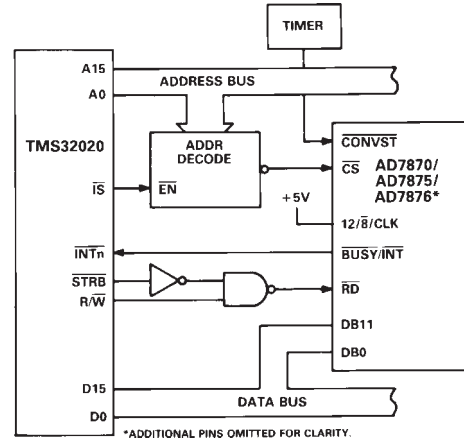

Figure 19. TMS32020 Parallel Interface

Two Byte Read Interfacing

68008 Interface

Figure 20 shows an 8-bit bus interface for the MC68008 microprocessor. For this interface, the $12/\overline{8}/\text{CLK}$ input is tied to 0 V and the DB11/HBEN pin is driven from the microprocessor least significant address bit. Conversion start control is provided by the microprocessor. In this interface example, a Move instruction from the ADC address both starts a conversion and reads the conversion result.

MOVEW ADC,DO

ADC = AD7870/AD7875/AD7876 address

D0 = 68008 D0 register

This is a two byte read instruction. During the first read operation $\overline{\text{BUSY}}$, in conjunction with $\overline{\text{CS}}$, forces the microprocessor to WAIT for the ADC conversion. At the end of conversion the ADC low byte (DB7-DB0) is loaded into D15-D8 of the D0 register and the ADC high byte (DB15-DB7) is loaded into D7-D0 of the D0 register. The following Rotate instruction to the D0 register swaps the high and low bytes to the correct format.

ROL = 8, D0.

Note: while executing the two byte read instruction above, WAIT states are inserted during the first read operation only and not for the second.

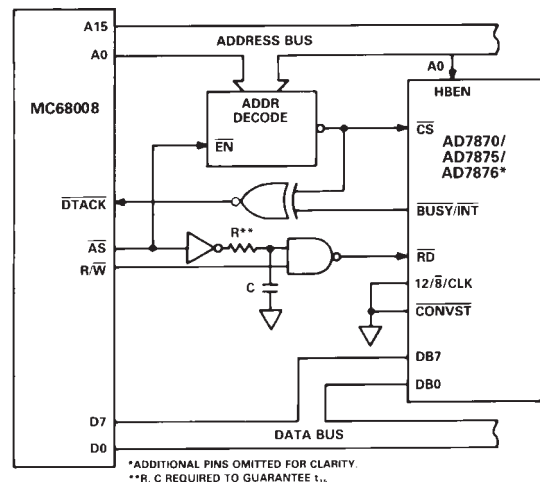

Figure 20. MC68008 Byte Interface

AD7870/AD7875/AD7876

Serial Interfacing

Figures 21 to 24 show the AD7870/AD7875/AD7876 configured for serial interfacing. In all four interfaces, the ADC is configured for Mode 1 operation. The interfaces show a timer driving the $\overline{\text{CONVST}}$ input, but this could be generated from a decoded address if required. The SCLK, SDAT and SSTRB are open-drain outputs. If these are required to drive capacitive loads in excess 35 pF, buffering is recommended.

DSP56000 Serial Interface

Figure 21 shows a serial interface between the AD7870/AD7875/AD7876 and the DSP56000. The interface arrangement is two-wire with the ADC configured for noncontinuous clock operation ($12/\overline{8}/\text{CLK} = 0 \text{ V}$). The DSP56000 is configured for normal mode asynchronous operation with gated clock. It is also set up for a 16-bit word with SCK and SC1 as inputs and the FSL control bit set to a 0. In this configuration, the DSP56000 assumes valid data on the first falling edge of SCK. Since the ADC provides valid data on this first edge, there is no need for a strobe or framing pulse for the data. SCLK and SDATA are gated off when the ADC is not performing a conversion. During conversion, data is valid on the SDATA output of the ADC and is clocked into the receive data shift register of the DSP56000. When this register has received 16 bits of data, it generates an internal interrupt on the DSP56000 to read the data from the register.

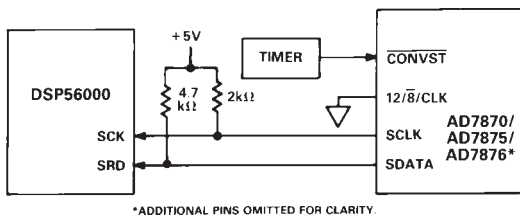

Figure 21. DSP56000 Serial Interface

The DSP56000 and AD7870/AD7875/AD7876 can also be configured for continuous clock operation ($12/\overline{8}/\text{CLK} = -5 \text{ V}$). In this case, a strobe pulse is required by the DSP56000 to indicate when data is valid. The SSTRB output of the ADC is inverted and applied to the SC1 input of the DSP56000 to provide this strobe pulse. All other conditions and connections are the same as for gated clock operation.

NEC7720/77230 Serial Interface

A serial interface between the AD7870/AD7875/AD7876 and the NEC7720 is shown in Figure 22. In the interface shown, the ADC is configured for continuous clock operation. This can be changed to a noncontinuous clock by simply tying the $12/\overline{8}/\text{CLK}$ input of the ADC to 0 V with all other connections remaining the same. The NEC7720 expects valid data on the rising edge of its SCLK input and therefore an inverter is required on the SCLK output of the ADC. The NEC7720 is configured for a 16-bit data word. Once the 16 bits of data have been received by the SI register of the NEC7720, an internal interrupt is generated to read the contents of the SI register.

The NEC77230 interface is similar to that just outlined for the NEC7720. However, the clock input of the NEC77230 is SICLK. Additionally, no inverter is required between the ADC SCLK output and this SICLK input since the NEC77230 assumes data is valid on the falling edge of SICLK.

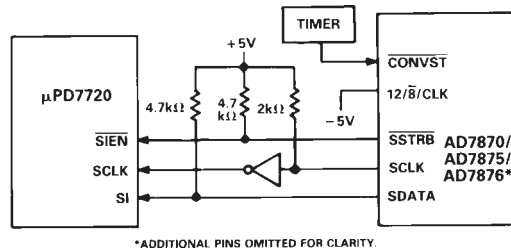

Figure 22. NEC7720 Serial Interface

TMS32020 Serial Interface

Figure 23 shows a serial interface between the AD7870/AD7875/AD7876 and the TMS32020. The AD7870/AD7875/AD7876 is configured for continuous clock operation. Note, the ADC will not interface correctly to the TMS32020 if the ADC is configured for a noncontinuous clock. Data is clocked into the data receive register (DRR) of the TMS32020 during conversion. As with the previous interfaces, when a 16-bit word is received by the TMS32020 it generates an internal interrupt to read the data from the DRR.

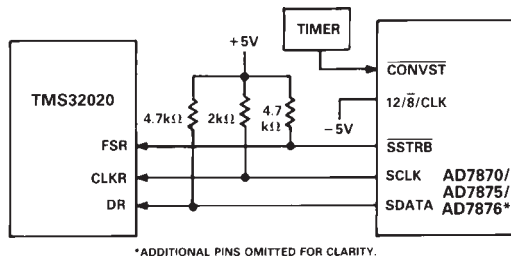

Figure 23. TMS32020 Serial Interface

ADSP-2101/ADSP-2102 Serial Interface

Figure 24 shows a serial interface between the AD7870/AD7875/AD7876 and the ADSP-2101/ADSP-2102. The ADC is configured for continuous clock operation. Data is clocked into the serial port register of the ADSP-2101/ADSP-2102 during conversion. As with the previous interfaces, when a 16-bit data word is received by the ADSP-2101/ADSP-2102 an internal microprocessor interrupt is generated and the data is read from the serial port register.

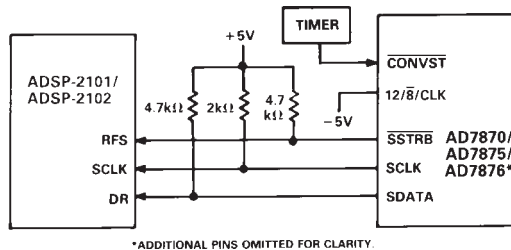
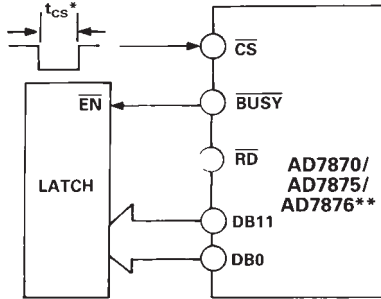

Figure 24. ADSP-2101/ADSP-2102 Serial Interface

STAND-ALONE OPERATION

The AD7870/AD7875/AD7876 can be used in its Mode 2, parallel interface mode for stand-alone operation. In this case, conversion is initiated with a pulse to the ADC \overline{CS} input. This pulse must be longer than the conversion time of the ADC. The \overline{BUSY} output is used to drive the \overline{RD} input. Data is latched from the ADC DB0–DB11 outputs to an external latch on the rising edge of \overline{BUSY} .



* $t_{CS} \gg t_{16} + t_{CONVERT}$
 **ADDITIONAL PINS OMITTED FOR CLARITY

Figure 25. Stand-Alone Operation

APPLICATION HINTS

Good printed circuit board (PCB) layout is as important as the overall circuit design itself in achieving high speed A/D performance. The designer has to be conscious of noise both in the ADC itself and in the preceding analog circuitry. Switching mode power supplies are not recommended as the switching spikes will feed through to the comparator causing noisy code transitions. Other causes of concern are ground loops and digital feedthrough from microprocessors. These are factors which influence any ADC, and a proper PCB layout which minimizes these effects is essential for best performance.

LAYOUT HINTS

Ensure that the layout for the printed circuit board has the digital and analog signal lines separated as much as possible. Take care not to run any digital track alongside an analog signal track. Guard (screen) the analog input with AGND.

Establish a single point analog ground (star ground) separate from the logic system ground at the AGND pin or as close as possible to the ADC. Connect all other grounds and the AD7870/AD7875/AD7876 DGND to this single analog ground point. Do not connect any other digital grounds to this analog ground point.

Low impedance analog and digital power supply common returns are essential to low noise operation of the ADC, so make the foil width for these tracks as wide as possible. The use of ground planes minimizes impedance paths and also guards the analog circuitry from digital noise. The circuit layout of Figures 30 and 31 have both analog and digital ground planes which are kept separated and only joined together at the AD7870/AD7875/AD7876 AGND pin.

NOISE

Keep the input signal leads to V_{IN} and signal return leads from AGND as short as possible to minimize input noise coupling. In applications where this is not possible, use a shielded cable between the source and the ADC. Reduce the ground circuit impedance as much as possible since any potential difference in

grounds between the signal source and the ADC appears as an error voltage in series with the input signal.

DATA ACQUISITION BOARD

Figure 28 shows the AD7870/AD7875/AD7876 in a data acquisition circuit. The corresponding printed circuit board (PCB) layout and silkscreen are shown in Figures 29 to 31. The board layout has three interface ports: one serial and two parallel. One of the parallel ports is directly compatible with the ADSP-2100 evaluation board expansion connector.

The only additional component required for a full data acquisition system is an antialiasing filter. A component grid is provided near the analog input on the PCB, which may be used for such a filter or any other input conditioning circuitry. To facilitate this option there is a shorting plug (labelled LK1 on the PCB) on the analog input track. If this shorting plug is used, the analog input connects to the buffer amplifier driving the ADC; if this shorting plug is omitted, a wire link can be used to connect the analog input to the PCB component grid.

INTERFACE CONNECTIONS

There are two parallel connectors labeled SKT4 and SKT6 and one serial connector labeled SKT5. A shorting plug option (LK3 in Figure 28) on the ADC $12/\overline{8}/\text{CLK}$ input configures the ADC for the appropriate interface (see Pin Function Description).

SKT6 is a 96-contact (3-ROW) Eurocard connector that is directly compatible with the ADSP-2100 Evaluation Board Prototype Expansion Connector. The expansion connector on the ADSP-2100 has eight decoded chip enable outputs labeled $\overline{ECE1}$ to $\overline{ECE8}$. $\overline{ECE6}$ is used to drive the ADC \overline{CS} input on the data acquisition board. To avoid selecting on board RAM sockets at the same time, LK6 on the ADSP-2100 board must be removed. In addition, the ADSP-2100 expansion connector has four interrupts labelled $\overline{EIRQ0}$ to $\overline{EIRQ3}$. The ADC $\overline{BUSY}/\overline{INT}$ output connects to $\overline{EIRQ0}$. There is a single wait state generator connected to EDMACK to allow the ADC to interface to the faster versions of the ADSP-2100.

SKT4 is a 26-way (2-ROW) IDC connector. This connector contains all the signal contacts as SKT6 with the exception of EDMACK which is connected to SKT6 only. It also contains decoded R/\overline{W} and \overline{STRB} inputs which are necessary for TMS32020 interfacing. The SKT4 pinout is shown in Figure 26.

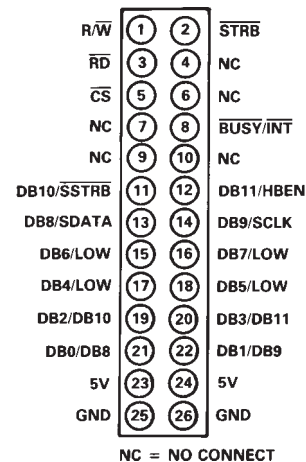

Figure 26. SKT4, IDC Connector Pinout

AD7870/AD7875/AD7876

SKT5 is a 9-way D-type connector that is meant for serial interfacing only. An inverted DB9/SCLK output is also provided on this connector for systems that accept data on a rising clock edge. The SKT5 pinout is shown in Figure 27.

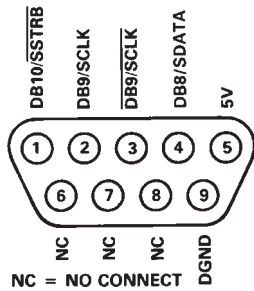

Figure 27. SKT5, D-Type Connector Pinout

SKT1, SKT2 and SKT3 are three BNC connectors which provide input connections for the analog input, the CONVST input and an external clock input. The use of an external clock source is optional; there is a shorting plug (LK2) on the ADC CLK input that must be connected to either -5 V (for the ADCs own internal clock) or to SKT3.

POWER SUPPLY CONNECTIONS

The PCB requires two analog power supplies and one 5 V digital supply. The analog supplies are labelled V+ and V-, and the range for both supplies is 12 V to 15 V (see silkscreen in Figure 29). Connection to the 5 V digital supply is made through any of the connectors (SKT4 to SKT6). The -5 V supply required by the ADC is generated from a voltage regulator on the V- power supply input (IC3 in Figure 27).

SHORTING PLUG OPTIONS

There are seven shorting plug options that must be set before using the board. These are outlined below:

- LK1 Connects the analog input to a buffer amplifier. The analog input may also be connected to a component grid for signal conditioning.
- LK2 Selects either the ADC internal clock or an external clock source.
- LK3 Configures the ADC $12/\bar{8}/\text{CLK}$ input for the appropriate serial or parallel interface.
- LK4 Connects the ADC $\overline{\text{RD}}$ input directly to the two parallel connectors or to a decoded $\overline{\text{STRB}}$ and $\text{R}/\overline{\text{W}}$ input. This shorting plug setting depends on the microprocessor e.g., the TMS32010 has a separate $\overline{\text{RD}}$ output while the TMS32020 has $\overline{\text{STRB}}$ and $\text{R}/\overline{\text{W}}$ outputs.
- LK5- Connect the pull-up resistors R3, R4 and R5 to $\overline{\text{SSTRB}}$,
- LK7 SCLK and SDATA. These shorting plugs should be removed for parallel interfacing.

COMPONENT LIST

IC1	AD711 Op Amp
IC2	AD7870/AD7875/AD7876 Analog-to-Digital Converter
IC3	MC79L05 -5 V Regulator
IC4	74HC00 Quad NAND Gate
IC5	74HC74 Dual D-Type Flip Flop
C1, C3, C5, C7, C9, C11	10 μF Capacitors
C2, C4, C6, C8, C10, C12	0.1 μF Capacitors
R1, R2	10 k Ω Pull-Up Resistors
R3*, R5*	4.7 k Ω Pull-Up Resistors
R4*	2 k Ω Pull-Up Resistor
LK1, LK2	Shorting Plugs
LK3, LK4	
LK5, LK6, LK7	
SKT1, SKT2, SKT3	BNC Sockets
SKT4	26-Contact (2-Row) IDC Connector
SKT5	9-Contact D-Type Connector
SKT6	96-Contact (3-Row) Eurocard Connector

*Required for Serial Communication only.

AD7870/AD7875/AD7876

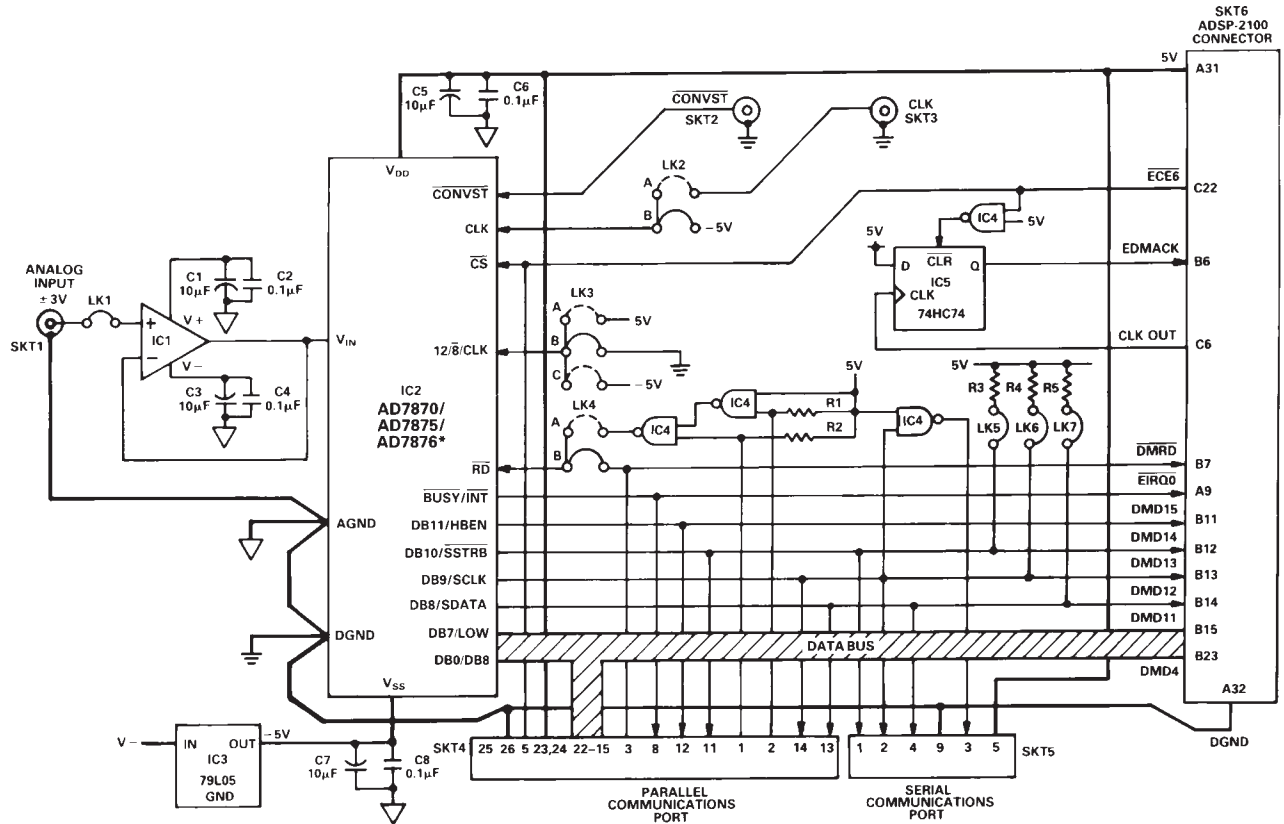

Figure 28. Data Acquisition Circuit Using the AD7870/AD7875/AD7876

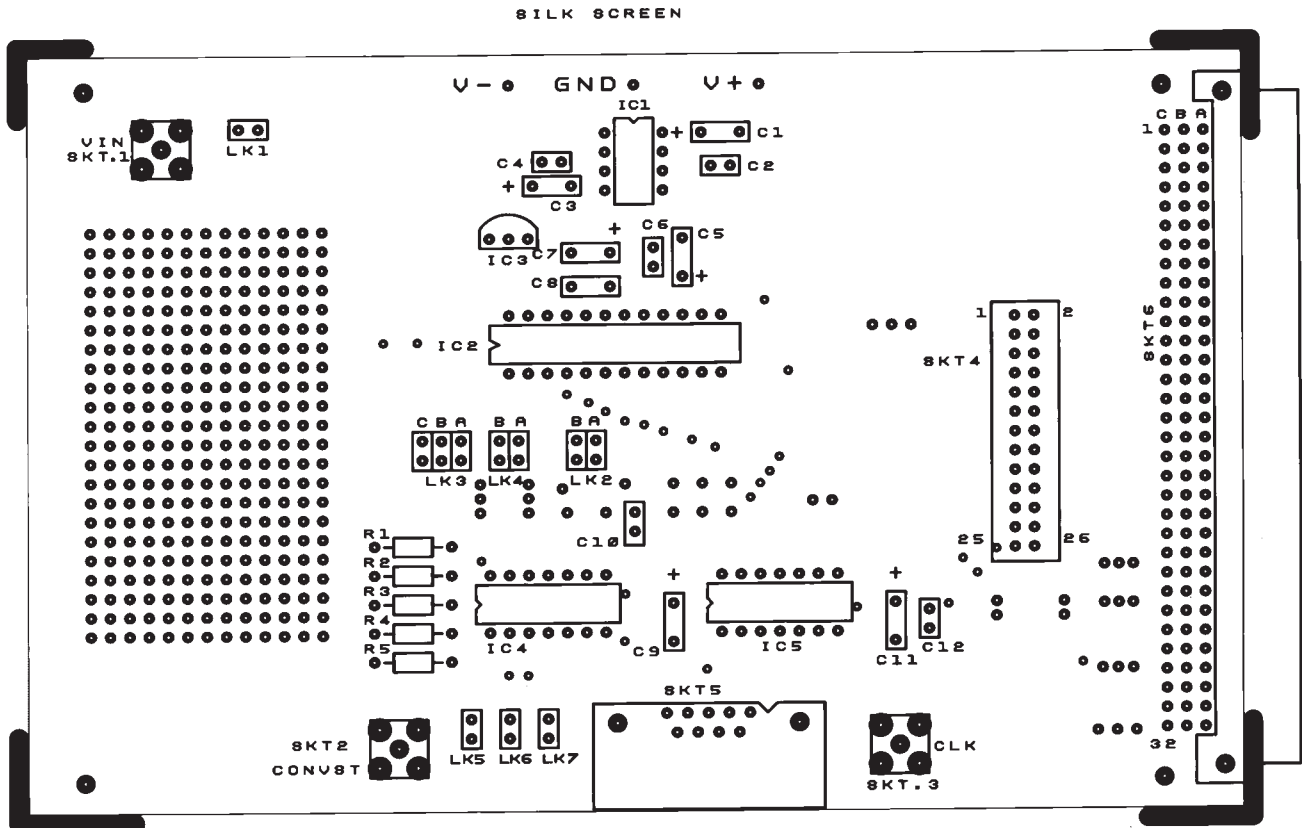

Figure 29. PCB Silkscreen for Figure 28

AD7870/AD7875/AD7876

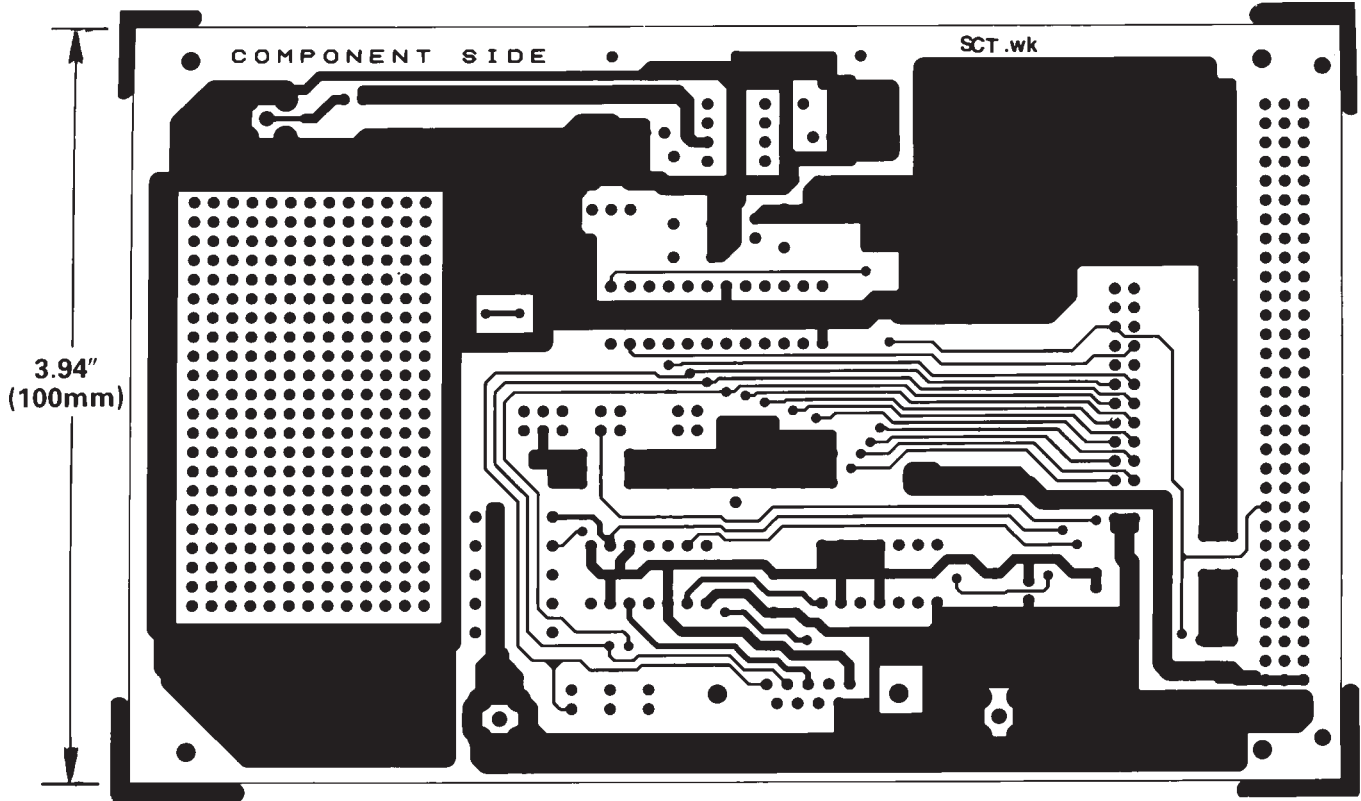

Figure 30. PCB Component Side Layout for Figure 28

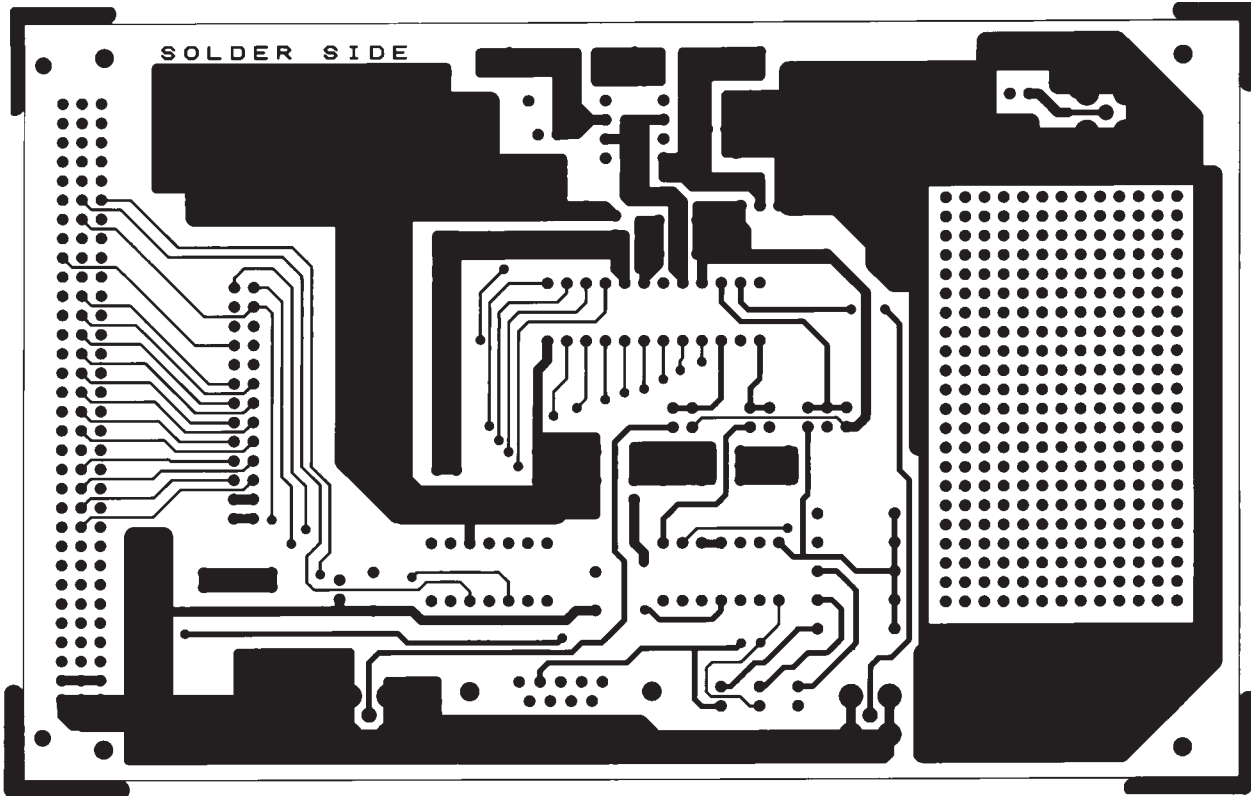
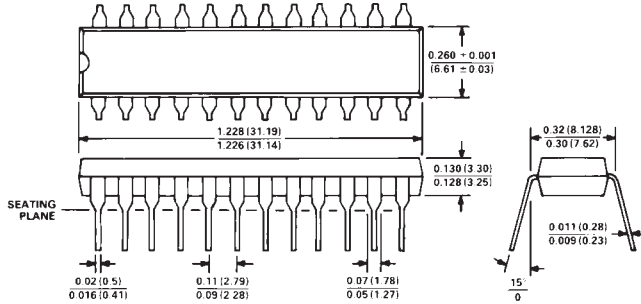

Figure 31. PCB Solder Side Layout for Figure 28

OUTLINE DIMENSIONS

Dimensions shown in inches and (mm).

24-Pin Plastic DIP (N-24)



- NOTES
1. LEAD NO. 1 IDENTIFIED BY DOT OR NOTCH.
 2. PLASTIC LEADS WILL BE EITHER SOLDER DIPPED OR TIN LEAD PLATED IN ACCORDANCE WITH MIL-M-38510 REQUIREMENTS.

28-Pin PLCC (P-28A)

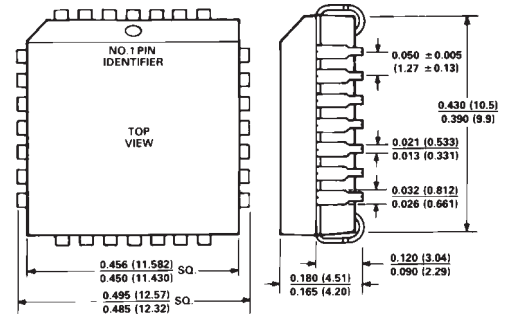

24-Pin Cerdip (Q-24)

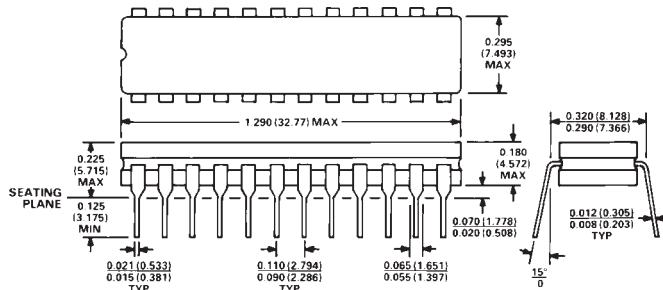

- NOTES
1. LEAD NO. 1 IDENTIFIED BY DOT OR NOTCH.
 2. CERDIP LEADS WILL BE EITHER TIN PLATED OR SOLDER DIPPED IN ACCORDANCE WITH MIL-M-38510 REQUIREMENTS.

24-Pin SOIC (R-24)

