

The AD9884 is a complete 8-bit 140MSPS, monolithic graphics digitizer optimized for digitizing RGB graphics signals from personal computers and workstations. Its 140MSPS encode rate capability and full-power analog bandwidth of 300MHz supports display resolutions of up to 1280 x 1024 at 75Hz with sufficient input bandwidth to accurately acquire and digitize each pixel.

To minimize system cost and power dissipation, the AD9884 includes an internal +1.25V reference, PLL to generate a pixel clock from HSYNC and VSYNC, and programmable gain and clamp control. The user provides only a +3.3V power supply, analog input, and HSYNC and VSYNC signals. Three-state CMOS outputs may be powered from 2.5V to 3.3V.

The AD9884's on-chip PLL generates a pixel clock from HSYNC and VSYNC inputs. Pixel clock output frequencies range from 20–140 MHz. PLL clock jitter is 500ps p-p typical relative to the input reference. When an external COAST signal is presented, the PLL maintains its output frequency in the absence of HSYNC. A sampling phase adjustment is provided. Data, HSYNC and Clock output phase relationships are maintained. The PLL can be disabled and an external clock input provided as the pixel clock.

A clamp signal is generated internally or may be provided by the user through the CLAMP input pin. This device is fully programmable via a two wire serial bus.

Fabricated in an advanced CMOS process, the AD9884 is provided in a space-saving 128-lead MQFP surface mount plastic package and is specified over the 0°C to +85°C temperature range.

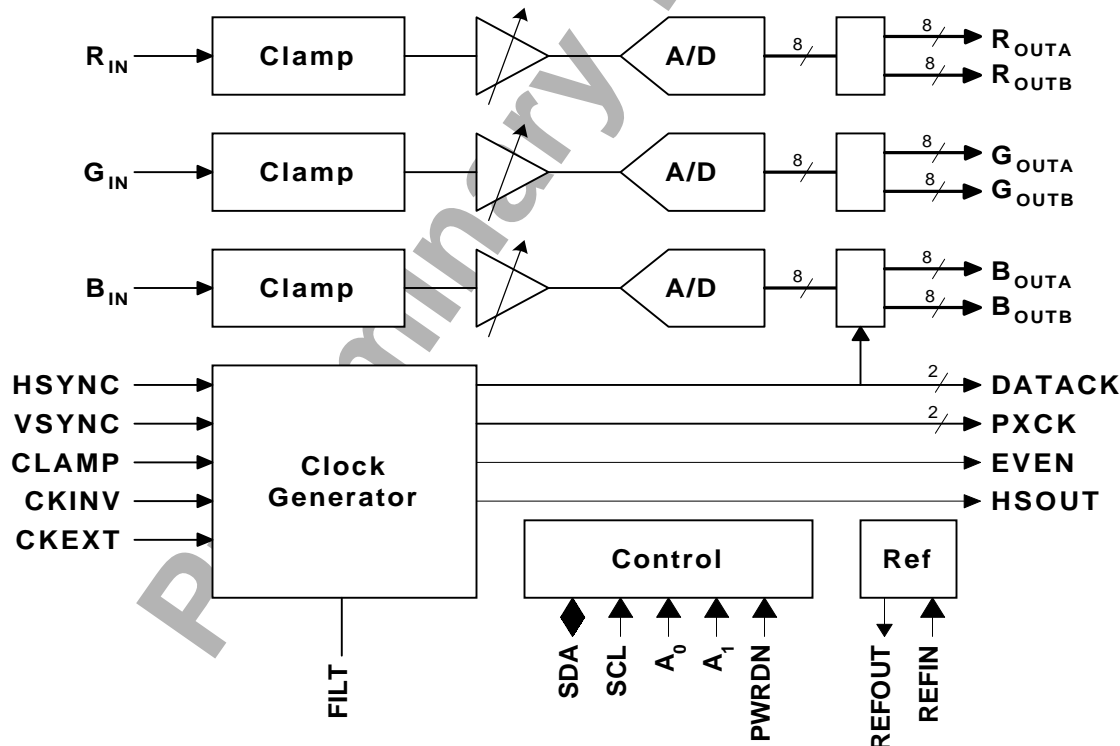
FEATURES
140 MSPS Maximum Conversion Rate
300 MHz Analog Bandwidth
0.5V to 1.0V Analog Input Range
500pS p-p PLL clock jitter
3.3V power supply
2.5V to 3.3V three-state CMOS outputs
Demultiplexed Output Ports
Data Clock Output Provided
Low Power : 800mW Typical
Internal PLL generates CLOCK from HSYNC
Serial bus interface
Fully programmable
Supports 2 pixels per clock mode
APPLICATIONS
RGB Graphics Processing
LCD Monitors and Projectors
Plasma Display Panels
Scan Converters

REV. 0

© Analog Devices, Inc., 1998

Information furnished by Analog Devices is believed to be accurate and reliable. However, no responsibility is assumed by Analog Devices for its use, nor for any infringements of patents or other rights of third parties which may result from its use. No license is granted by implication or otherwise under any patent or patent rights of Analog Devices.

One Technology Way, P.O. Box 9106, Norwood, MA 02062-9106, USA
Tel: 617/329-4700 Fax: 617-326-8703

CRITICAL CHARACTERISTICS ($V_{DD} = +3.3V$, $V_D = +3.3V$, ENCODE = 140MHz)

Parameter	Temp	Test Level	AD9884KS			Units
			Min	Typical	Max	
RESOLUTION				8		bits
DC ACCURACY						
Differential Nonlinearity	+25°C	I		0.5		LSB
	Full	VI		0.9		LSB
Integral Nonlinearity	+25°C	I		0.5		LSB
	Full	VI		0.9		LSB
No Missing Codes	Full	VI	Guaranteed			
Gain Tempco	Full	V		TBD		ppm/°C
ANALOG INPUT						
Input Voltage Range	Full	V	0.5		1.0	V p-p
Input Resistance	+25°C	I		TBD		kΩ
	Full	VI		TBD		kΩ
Input Capacitance	+25°C	V		4		pF
Input Bias Current	+25°C	I		TBD		μA
	Full	VI		TBD		μA
Analog Bandwidth, Full Power	+25°C	V		300		MHz
REFERENCE OUTPUT						
Output Voltage	Full	VI		+1.25		V
Temperature Coefficient	Full	V		50		ppm/°C
SWITCHING PERFORMANCE						
Maximum Conversion Rate	Full	VI	140			MSPS
Minimum Conversion Rate	Full	IV		20		MSPS
Data to Clock Skew	Full	VI		TBD		ns
DIGITAL INPUTS						
Input Capacitance	+25°C	V		3		pF
DIGITAL OUTPUTS						
Logic "1" Voltage	Full	VI	$V_D - 0.1$			V
Logic "0" Voltage	Full	VI			0.1	V
Output Coding					Binary	
POWER SUPPLY						
V_{CC} Supply Current	Full	VI		180		mA
V_{DD} Supply Current	Full	VI		60		mA
Total Power Dissipation	Full	VI		800		mW
Powerdown Supply Current	Full	VI		TBD		mA
Powerdown Dissipation	Full	VI		TBD		mW
DYNAMIC PERFORMANCE						
Transient Response	+25°C	V		TBD		ns
Overvoltage Recovery Time	+25°C	V		1.5		ns
Signal-to-Noise Ratio (SNR)						
(Without Harmonics)						
$f_{IN} = 19.7$ MHz	+25°C	I		45		dB
	Full	V		45		dB
Signal-to-Noise Ratio (SINAD)						
(With Harmonics)						
$f_{IN} = 19.7$ MHz	+25°C	I		43		dB
	Full	V		43		dB
Effective Number of Bits						
$f_{IN} = 19.7$ MHz	+25°C	I		6.8		bits
Crosstalk	+25°C	V		60		dBc
	Full	V		55		dBc

ORDERING GUIDE

Model	Temperature Range	Package Option
AD9884KS	0°C to +85°C	ST-128
AD9884/PCB	+25°C	Evaluation Board

EXPLANATION OF TEST LEVELS**Test Level**

- I 100% production tested.
- II 100% production tested at +25°C and sample tested at specified temperatures.
- III Sample tested only.
- IV Parameter is guaranteed by design and characterization testing.
- V Parameter is a typical value only.
- VI 100% production tested at +25°C; guaranteed by design and characterization testing.

ABSOLUTE MAXIMUM RATINGS*

V_D	+4 V
V_{DD}	+4 V
Analog Inputs	V_{DD} to 0.0 V
VREF IN	V_{DD} to 0.0 V
Digital Inputs	V_{DD} to 0.0 V
Digital Output Current	20 mA
Operating Temperature	0°C to +85°C
Storage Temperature	-65°C to +150°C
Maximum Junction Temperature	+175°C
Maximum Case Temperature	+150°C

- Stresses above those listed under "Absolute Maximum Ratings" may cause permanent damage to the device. This is a stress rating only and functional operation of the device at these or any other conditions outside of those indicated in the operation sections of this specification is not implied. Exposure to absolute maximum ratings for extended periods may affect device reliability.

AD9884

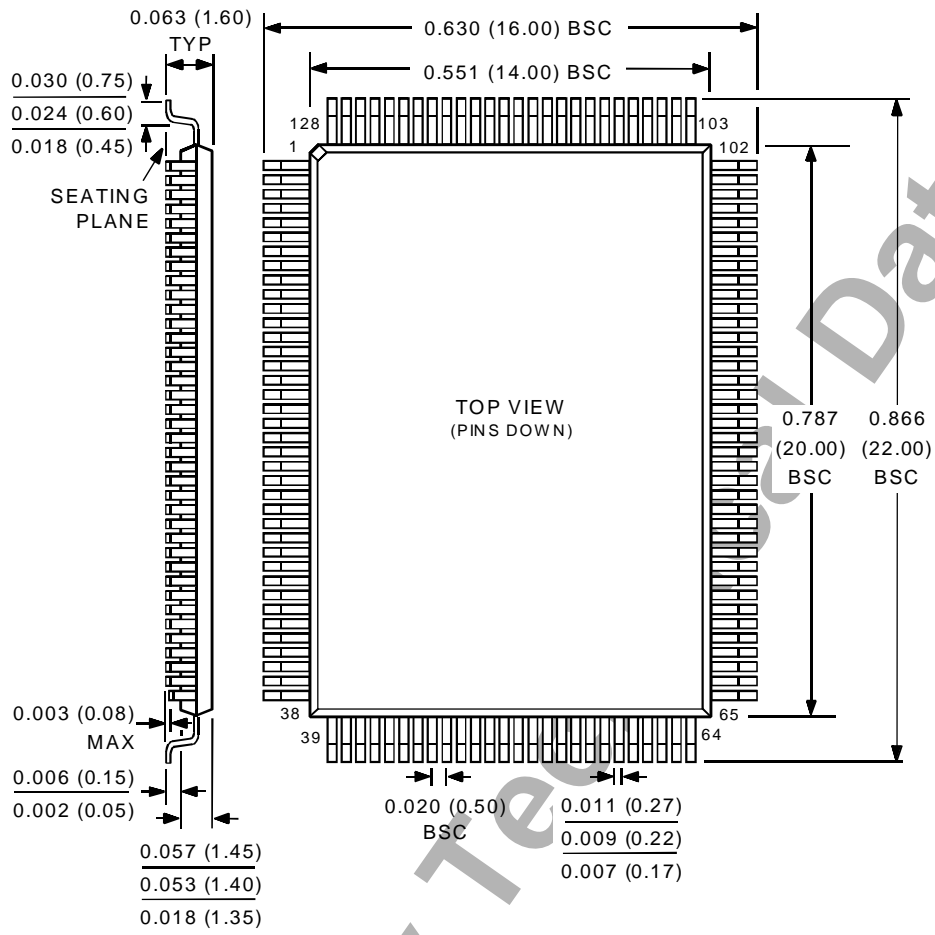

Preliminary Technical Information