



ADC803

High Speed ANALOG-TO-DIGITAL CONVERTER

FEATURES

- 12-BIT RESOLUTION
- LINEARITY ERROR: $\pm 0.12\%$, max (C Grade)
- NO MISSING CODES: -55°C to $+125^{\circ}\text{C}$ (S Grade)
- HIGH SINAD RATIO: 72dB
- LOW HARMONIC DISTORTION: -73dB
- CONVERSION TIME: 500ns, 8 Bits
670ns, 10 Bits
1.5 μs , 12 Bits

DESCRIPTION

The ADC803 is a high speed hybrid successive approximation analog-to-digital converter utilizing laser-trimmed thin film components.

It is complete with internal reference, clock, and comparator, and is packaged in a 32-pin metal package. Conversion time is set at the factory to 1.5 μs .

With user-adjusted conversion time set at 1 μs , $\pm 1\text{LSB}$ accuracy can be achieved. The gain and offset errors may be externally trimmed to zero.

Internal scaling resistors are provided for the selection of analog signal input ranges of 0V to -10V , $\pm 5\text{V}$, and $\pm 10\text{V}$.

Output codes available are complementary binary for unipolar inputs and bipolar offset binary for bipolar inputs.

All digital inputs and outputs are TTL-compatible. Power supply requirements are $\pm 15\text{V}$ and $+5\text{V}$.

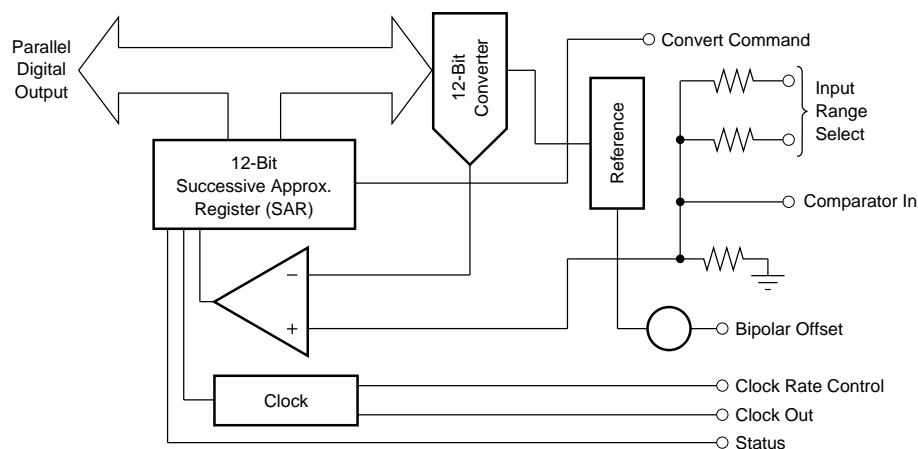

International Airport Industrial Park • Mailing Address: PO Box 11400 • Tucson, AZ 85734 • Street Address: 6730 S. Tucson Blvd. • Tucson, AZ 85706
Tel: (520) 746-1111 • Twx: 910-952-1111 • Cable: BBRCORP • Telex: 066-6491 • FAX: (520) 889-1510 • Immediate Product Info: (800) 548-6132

SPECIFICATIONS

At +25°C, rated power supplies, 1.5µs conversion time, and after 6-minute warm-up, unless otherwise noted.

PARAMETER	ADC803CM			ADC803BM			ADC803SM			UNITS
	MIN	TYP	MAX	MIN	TYP	MAX	MIN	TYP	MAX	
RESOLUTION			12			12			12	Bits
INPUTS										
ANALOG Voltage Ranges: Bipolar Unipolar Impedance: -10V to 0V, ±5V ±10V		±5, ±10 0 to -10 1.4 2.4			*			*		V V kΩ kΩ
DIGITAL Convert Command Logic Loading		Negative pulse 50ns wide (min) trailing edge (0 to 1) initiates conversion.								TTL Loads
TRANSFER CHARACTERISTICS										
ACCURACY Gain Error ⁽¹⁾ Offset Error ⁽¹⁾ : Unipolar Bipolar Linearity Error: 1.5µs Conversion Time 1.0µs Conversion Time Differential Linearity Error: 1.5µs Conversion Time 1.0µs Conversion Time Inherent Quantization Error		±0.04 ±0.05 ±0.02 ±0.009 ±0.015 ±0.012 ±0.015 1/2	±0.1 ±0.2 ±0.1 ±0.012 ±0.020 ±0.015 ±0.024		±0.08 ±0.07 * ±0.020 ±0.024 *	±0.2 ±0.3 ±0.2 ±0.020 ±0.020		±0.04 ±0.1 * ±0.012 * *	±0.1 * * ±0.015 * *	% % of FSR ⁽²⁾ % of FSR % of FSR % of FSR % of FSR % of FSR % of FSR LSB
POWER SUPPLY SENSITIVITY Gain and Offset: +15VDC -15VDC +5VDC Conversion Time: +15VDC -15VDC +5VDC		±0.0036 ±0.0005 ±0.001 ±0.7 None ±0.8			*	*		*	*	% of FSR/%V _{CC} % of FSR/%V _{CC} % of FSR/%V _{DD} %/V _{CC} %/V _{CC} %/V _{DD}
CONVERSION TIME Factory Set Range of Adjustments	1.3 0.8		1.5 2.2	*		*	*	*	*	µs µs
DRIFT Gain Offset: Unipolar Bipolar Linearity Error -25°C to +85°C: 1.5µs Conversion Time 1.0µs Conversion Time -55°C to +125°C: 1.7µs Conversion Time, max ⁽⁴⁾ Differential Linearity Error -25°C to +85°C: 1.5µs Conversion Time 1.0µs Conversion Time -55°C to +125°C: 1.7µs Conversion Time, max ⁽⁴⁾ Conversion Time No Missing Code Temp. Range: 1.5µs Conversion Time 1.7µs Conversion Time, max ⁽⁴⁾		±10 ±2 ±3 ±0.012 ±0.015 ±0.012 ±0.015 ±0.1	±30 ±7 ±10 ±0.018 ±0.018 ±0.018 ±0.018		±15 ±3 ±5 ±0.020 ±0.024 ±0.024 *	*	*	*	*	ppm of FSR/°C ppm of FSR/°C ppm of FSR/°C % of FSR % of FSR % of FSR % of FSR % of FSR % of FSR °C °C
OUTPUT										
DIGITAL DATA Parallel Output Codes: Unipolar Bipolar Output Drive Status Status Output Drive Internal Clock Clock Output Drive Frequency (without external clock adj.)		Complementary Straight Binary Bipolar Offset Binary 6 Logic "1" During Conversion 6 3 8								TTL Loads TTL Loads TTL Loads MHz

The information provided herein is believed to be reliable; however, BURR-BROWN assumes no responsibility for inaccuracies or omissions. BURR-BROWN assumes no responsibility for the use of this information, and all use of such information shall be entirely at the user's own risk. Prices and specifications are subject to change without notice. No patent rights or licenses to any of the circuits described herein are implied or granted to any third party. BURR-BROWN does not authorize or warrant any BURR-BROWN product for use in life support devices and/or systems.



SPECIFICATIONS (CONT)

At +25°C, rated power supplies, 1.5µs conversion time, and after 6-minute warm-up, unless otherwise noted.

PARAMETER	ADC803CM			ADC803BM			ADC803SM			UNITS
	MIN	TYP	MAX	MIN	TYP	MAX	MIN	TYP	MAX	
POWER SUPPLY REQUIREMENTS										
Power Consumption										
Rated Voltage: Analog ($\pm V_{CC}$)	±14.25	±15	±15.75	*	*	*	*	*	*	VDC
Digital (V_{DD})	+4.75	+5	+5.25	*	*	*	*	*	*	VDC
Supply Drain: +15V		+27	+32		*	*		*	*	mA
-15V		-38	-55		*	*		*	*	mA
+5V		+180	+210		*	*		*	*	mA
TEMPERATURE RANGE (Ambient)										
Specification	-25		+85	*		*	-55		+125	°C
Storage	-55		+125	*		*	*		*	°C

* Same specification as for ADC803CM.

NOTES: (1) Adjustable to zero. See Optional Gain and Offset Adjustment section. (2) FSR means Full Scale Range. For example, unit connected for ±10V has 20V FSR. (3) See Optional Clock Rate Control section. For faster conversion time at less resolution, see section on External Short Cycle. (4) Conversion time is factory-set at approximately 1.4µs at +25°C. As temperature increases, the conversion time increases. At +125°C the conversion time will be no more than 1.7µs. No Missing Codes is guaranteed over -55°C to +125°C provided the conversion time is allowed to increase with temperature.

ADC803 dynamic performance characteristics are described in a report titled "Analogue-to-Digital Converter Performance Tests Using the Fast Fourier Transform" by R. A. Belcher, University College of Swansea, Wales, UK. (available from Burr-Brown on letterhead request).

CONNECTION DIAGRAM

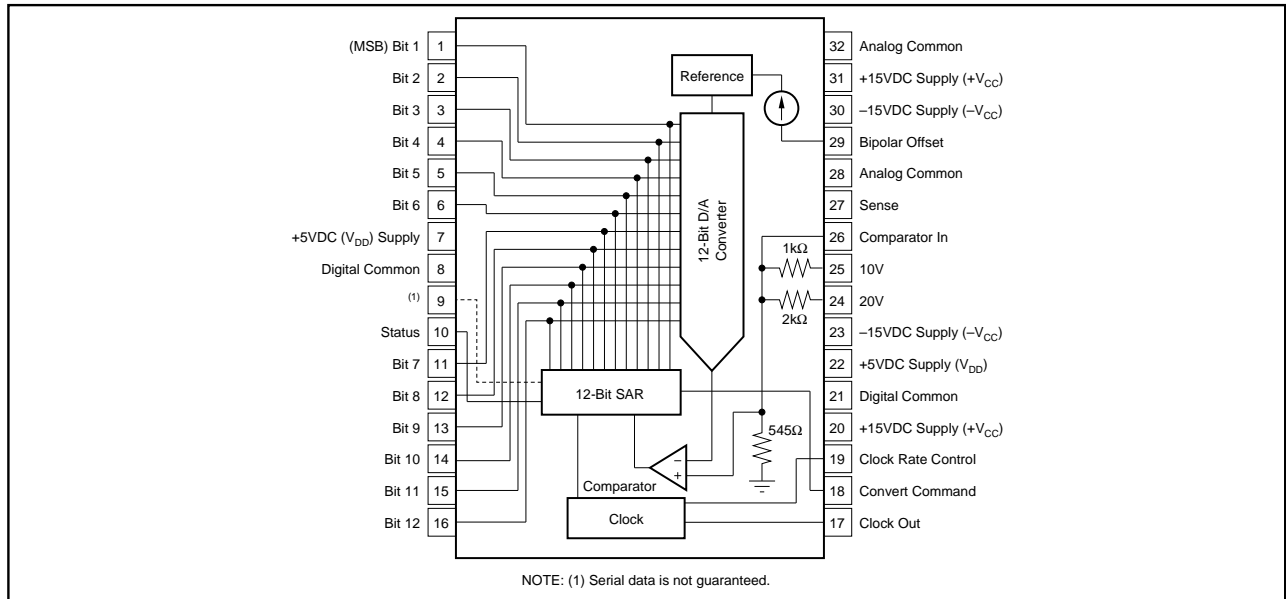

ORDERING INFORMATION

Basic Model Number	ADC803	X	M	Q
Performance Grade Code				
B, C = -25°C to +85°C				
S = -55°C to +125°C				
Package Code				
M = Metal DIP				
Reliability Screening				
Q = Q-Screened				

ABSOLUTE MAXIMUM RATINGS

Analog Supply Voltage To Analog Common	±18V
Digital Supply Voltage To Digital Common	+7V
Digital Controls Inputs	+5.5V
Analog Inputs	±15V
Operating Temperature: Ambient	+125°C
Case	+135°C
Storage Temperature	+125°C

PACKAGE INFORMATION

MODEL	PACKAGE	PACKAGE DRAWING NUMBER ⁽¹⁾
ADC803	32-Pin Metal	116

NOTE: (1) For detailed drawing and dimension table, please see end of data sheet, or Appendix D of Burr-Brown IC Data Book.