



# 15 kV ESD Protected, 2.7 V to 3.6 V Serial Port Transceivers with Green Idle™

## ADM3307E/ADM3310E/ADM3311E/ADM3312E/ADM3315E\*

### FEATURES

- Green Idle Power-Saving Mode
- Single 2.7 V to 3.6 V Power Supply
- Operates with 3 V Logic
- 0.1  $\mu$ F to 1  $\mu$ F Charge Pump Capacitors
- Low EMI
- Low Power Shutdown: 20 nA
- Full RS-232 Compliance
- 460 kbits/s Data Rate
- One Receiver Active in Shutdown (Two for ADM3310E)
- ESD >15 kV IEC 1000-4-2 on RS-232 I/Os (ADM33xxE)
- ESD >15 kV IEC 1000-4-2 on CMOS and RS-232 I/Os (ADM3307E)

### APPLICATIONS

- Mobile Phone Handsets/Data Cables
- Laptop and Notebook Computers
- Printers
- Peripherals
- Modems
- PDAs/Hand-Held Devices/Palmtop Computers

### GENERAL DESCRIPTION

The ADM33xxE line of driver/receiver products is designed to fully meet the EIA-232 standard while operating with a single 2.7 V to 3.6 V power supply. The devices feature an on-board, charge pump, dc-to-dc converter, eliminating the need for dual power supplies. This dc-to-dc converter contains a voltage tripler and voltage inverter that internally generates positive and negative supplies from the input 3 V power supply. The dc-to-dc converter operates in Green Idle Mode, whereby the charge pump oscillator is gated ON and OFF to maintain the output voltage at  $\pm 7.25$  V under varying load conditions. This minimizes the power consumption and makes these products ideal for battery-powered portable devices.

The ADM33xxE devices are suitable for operation in harsh electrical environments and contain ESD protection up to  $\pm 15$  kV on their RS-232 lines (ADM3310E, ADM3311E, ADM3312E, and ADM3315E). The ADM3307E contains ESD protection up to  $\pm 15$  kV on all I/O lines (CMOS, RS-232,  $\overline{\text{EN}}$ , and SD).

A shutdown facility that reduces the power consumption to 66 nW is also provided. While in shutdown, one receiver remains active (two receivers active with ADM3310E), thereby allowing monitoring of peripheral devices. This feature allows the device to be shut down until a peripheral device begins communication.

\*Protected by U.S. Patent No. 5,606,491.  
Green Idle is a trademark of Analog Devices, Inc.

### REV. F

Information furnished by Analog Devices is believed to be accurate and reliable. However, no responsibility is assumed by Analog Devices for its use, nor for any infringements of patents or other rights of third parties that may result from its use. No license is granted by implication or otherwise under any patent or patent rights of Analog Devices.

The active receiver can alert the processor, which can then take the ADM33xxE device out of the shutdown mode.

The ADM3307E contains five drivers and three receivers and is intended for mobile phone data lump cables and portable computing applications.

The ADM3311E contains three drivers and five receivers and is intended for serial port applications on notebook/laptop computers.

The ADM3310E is a low current version of the ADM3311E. This device also allows two receivers to be active in shutdown mode.

The ADM3312E contains three drivers and three receivers and is intended for serial port applications, PDAs, mobile phone data lump cables, and other hand-held devices.

The ADM3315E is a low current version of the ADM3312E, with a 22 k $\Omega$  receiver input resistance that reduces the drive requirements of the DTE. Its main applications are PDAs, palmtop computers, and mobile phone data lump cables.

The ADM33xxE devices are fabricated using CMOS technology for minimal power consumption. All parts feature a high level of overvoltage protection and latch-up immunity.

All ADM33xxE devices are available in a 32-lead 5 mm  $\times$  5 mm LFCSP package and in a TSSOP package (ADM3307E, ADM3310E, and ADM3311E in a 28-lead TSSOP; ADM3312E and ADM3315E in a 24-lead TSSOP). The ADM3311E also comes in a 28-lead SSOP package.

The ADM33xxE devices are ruggedized RS-232 line drivers/receivers that operate from a single supply of 2.7 V to 3.6 V. Step-up voltage converters coupled with level shifting transmitters and receivers allow RS-232 levels to be developed while operating from a single supply. Features include low power consumption, Green Idle operation, high transmission rates, and compatibility with the EU directive on electromagnetic compatibility. This EM compatibility directive includes protection against radiated and conducted interference, including high levels of electrostatic discharge.

All RS-232 (and CMOS, SD, and EN for ADM3307E) inputs and outputs are protected against electrostatic discharges (up to  $\pm 15$  kV). This ensures compliance with IEC 1000-4-2 requirements.

These devices are ideally suited for operation in electrically harsh environments or where RS-232 cables are frequently being plugged/unplugged. They are also immune to high RF field strengths without special shielding precautions.

Emissions are also controlled to within very strict limits. CMOS technology is used to keep the power dissipation to an absolute minimum, allowing maximum battery life in portable applications.

One Technology Way, P.O. Box 9106, Norwood, MA 02062-9106, U.S.A.  
Tel: 781/329-4700 [www.analog.com](http://www.analog.com)  
Fax: 781/326-8703 © Analog Devices, Inc., 2002

# ADM33xxE

## FUNCTIONAL BLOCK DIAGRAMS

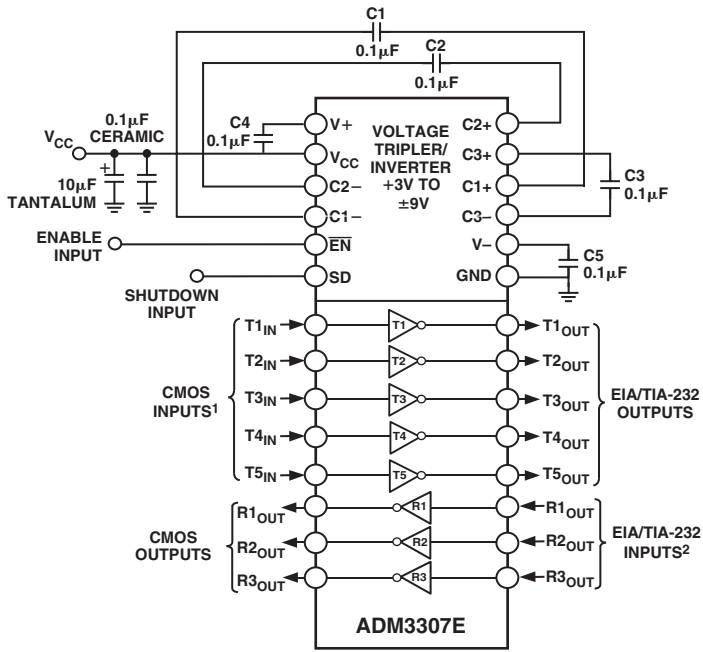

### NOTES

- <sup>1</sup>INTERNAL 400 kΩ PULL-UP RESISTOR ON EACH CMOS INPUT.
- <sup>2</sup>INTERNAL 5 kΩ PULL-DOWN RESISTOR ON EACH RS-232 INPUT.

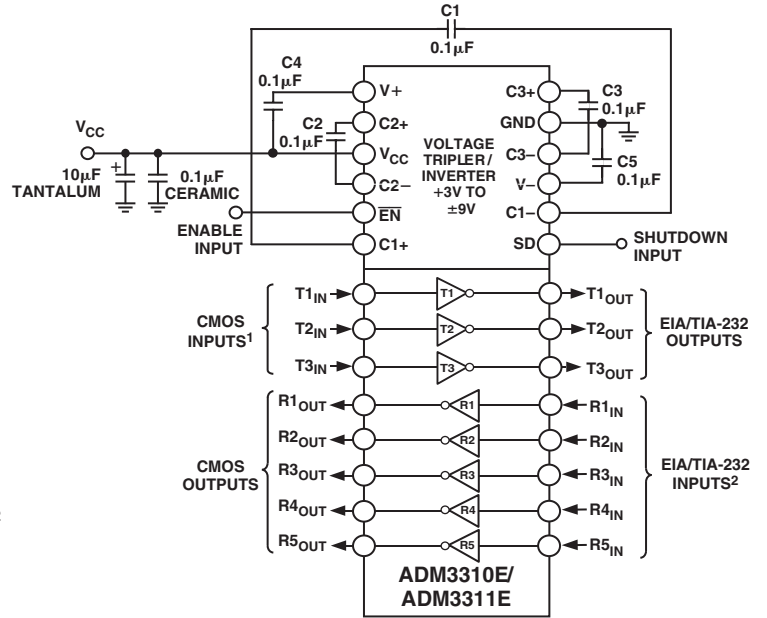

### NOTES

- <sup>1</sup>INTERNAL 400 kΩ PULL-UP RESISTOR ON EACH CMOS INPUT.
- <sup>2</sup>INTERNAL 5 kΩ PULL-DOWN RESISTOR ON EACH RS-232 INPUT.

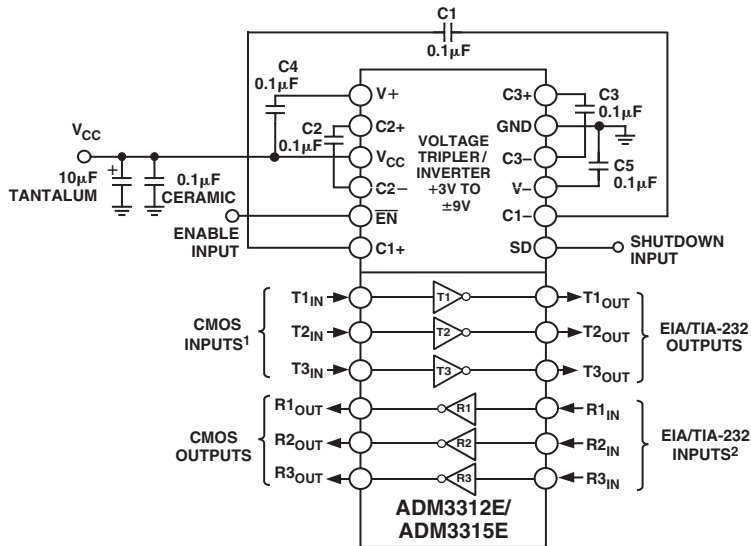

### NOTES

- <sup>1</sup>INTERNAL 400 kΩ PULL-UP RESISTOR ON EACH CMOS INPUT.
- <sup>2</sup>INTERNAL 5 kΩ (22 kΩ FOR ADM3315E) PULL-DOWN RESISTOR ON EACH RS-232 INPUT.

# SPECIFICATIONS ( $V_{CC} = 2.7\text{ V to }3.6\text{ V}$ , $C1-C5 = 0.1\ \mu\text{F}$ . All specifications $T_{MIN}$ to $T_{MAX}$ , unless otherwise noted.)

Parameter	Min	Typ	Max	Unit	Test Conditions/Comments
Operating Voltage Range	2.7	3.3	3.6	V	
$V_{CC}$ Power Supply Current					
ADM3307E		0.75	1.5	mA	$V_{CC} = 3.0\text{ V to }3.6\text{ V}$ ; No Load
ADM3311E, ADM3312E		0.75	4.5	mA	$V_{CC} = 2.7\text{ V to }3.6\text{ V}$ ; No Load
		0.45	1	mA	No Load; $V_{CC} = 3.0\text{ V to }3.6\text{ V}$ ; $T_A = 0^\circ\text{C}$ to $85^\circ\text{C}$
		0.45	4.5	mA	No Load; $V_{CC} = 2.7\text{ V to }3.6\text{ V}$ ; $T_A = -40^\circ\text{C}$ to $+85^\circ\text{C}$
ADM3310E, ADM3315E		0.35	0.85	mA	$V_{CC} = 2.7\text{ V to }3.6\text{ V}$ ; No Load
ADM3310E, ADM3311E,			35	mA	$R_L = 3\text{ k}\Omega$ to GND on all $T_{OUTS}$
ADM3312E, ADM3315E					
Shutdown Supply Current		0.02	1	$\mu\text{A}$	
Input Pull-Up Current		10	25	$\mu\text{A}$	$T_{IN} = \text{GND}$
Input Leakage Current, SD, $\overline{\text{EN}}$		0.02	$\pm 1$	$\mu\text{A}$	
Input Logic Threshold Low, $V_{INL}$			0.8	V	$T_{IN}, \overline{\text{EN}}, \text{SHDN}$
			0.4	V	$T_{IN}, \overline{\text{EN}}, \text{SHDN}; V_{CC} = 2.7\text{ V}$
Input Logic Threshold High, $V_{INH}$	2.0			V	$T_{IN}, \overline{\text{EN}}, \text{SHDN}$
CMOS Output Voltage Low, $V_{OL}$			0.4	V	$I_{OUT} = 1.6\text{ mA}$
CMOS Output Voltage High, $V_{OH}$	$V_{CC} - 0.6$			V	$I_{OUT} = -200\ \mu\text{A}$
CMOS Output Leakage Current					
ADM3307E		0.04	$\pm 1$	$\mu\text{A}$	$\overline{\text{EN}} = V_{CC}, 0\text{ V} < R_{OUT} < V_{CC}$
ADM3310E, ADM3311E		0.05	$\pm 5$	$\mu\text{A}$	$\overline{\text{EN}} = V_{CC}, 0\text{ V} < R_{OUT} < V_{CC}$
ADM3312E, ADM3315E					
Charge Pump Output Voltage, V+		+7.25		V	No Load
ADM3307E, ADM3311E, ADM3312E					
Charge Pump Output Voltage, V-		-7.25		V	No Load
ADM3307E, ADM3311E, ADM3312E					
Charge Pump Output Voltage, V+		+6.5		V	No Load
ADM3310E, ADM3315E					
Charge Pump Output Voltage, V-		-6.5		V	No Load
ADM3310E, ADM3315E					
EIA-232 Input Voltage Range	-25		+25	V	
EIA-232 Input Threshold Low	0.4	1.3		V	
EIA-232 Input Threshold High		2.0	2.4	V	
EIA-232 Input Hysteresis		0.14		V	
EIA-232 Input Resistance					
ADM3307E, ADM3310E, ADM3311E,	3	5	7	k $\Omega$	
ADM3312E					
ADM3315E	14	22	31	k $\Omega$	

# ADM33xxE

## SPECIFICATIONS (continued)

Parameter	Min	Typ	Max	Unit	Test Conditions/Comments
Output Voltage Swing ADM3310E, ADM3315E		±5.0	±5.5	V	All Transmitter Outputs Loaded with 3 kΩ to Ground (V <sub>CC</sub> = 3.0 V) (V <sub>CC</sub> = 2.7 V) All Transmitter Outputs Loaded with 3 kΩ to Ground V <sub>CC</sub> = 0 V, V <sub>OUT</sub> = ±2 V
ADM3307E, ADM3311E, ADM3312	±5.0	±6.4 ±5.5		V V	
Transmitter Output Resistance	300			Ω	
RS-232 Output Short Circuit Current		±15	±60	mA	
Maximum Data Rate ADM3307E	250	720		kbps	R <sub>L</sub> = 3 kΩ to 7 kΩ, C <sub>L</sub> = 50 pF to 1000 pF, V <sub>CC</sub> = 2.7 V
	460	920		kbps	R <sub>L</sub> = 3 kΩ to 7 kΩ, C <sub>L</sub> = 50 pF to 1000 pF, V <sub>CC</sub> = 3.0 V
ADM3310E, ADM3311E, ADM3312E ADM3315E	250	460		kbps	R <sub>L</sub> = 3 kΩ to 7 kΩ, C <sub>L</sub> = 50 pF to 1000 pF, V <sub>CC</sub> = 3.0 V
Receiver Propagation Delay, T <sub>PHL</sub> , T <sub>PLH</sub>		0.3		μs	C <sub>L</sub> = 150 pF
		0.17	1	μs	C <sub>L</sub> = 150 pF; ADM3307E Only
Receiver Output Enable Time, t <sub>ER</sub>		100		ns	
Receiver Output Disable Time, t <sub>DR</sub>		300		ns	
Transmitter Propagation Delay, T <sub>PHL</sub> , T <sub>PLH</sub>		500		ns	R <sub>L</sub> = 3 kΩ, C <sub>L</sub> = 1000 pF
Transition Region Slew Rate	3	18		V/μs	R <sub>L</sub> = 3 kΩ, C <sub>L</sub> = 50 pF to 1000 pF <sup>1</sup>
ESD PROTECTION (I/O PINS)		±15		kV	Human Body Model
		±15		kV	IEC 1000-4-2 Air Discharge
		±8		kV	IEC 1000-4-2 Contact Discharge <sup>2</sup>

### NOTES

<sup>1</sup>Measured at +3 V to -3 V or -3 V to +3 V.

<sup>2</sup>Includes CMOS I/O, SD, and  $\overline{\text{EN}}$  for ADM3307E.

Specification subject to change without notice.

### ABSOLUTE MAXIMUM RATINGS\*

(T<sub>A</sub> = 25°C, unless otherwise noted)

V<sub>CC</sub> ..... -0.3 V to +4 V

V<sup>+</sup> ..... (V<sub>CC</sub> - 0.3 V) to +9 V

V<sup>-</sup> ..... +0.3 V to -9 V

#### Input Voltages

T<sub>IN</sub> ..... -0.3 V to +6 V

R<sub>IN</sub> ..... ±30 V

#### Output Voltages

T<sub>OUT</sub> ..... ±15 V

R<sub>OUT</sub> ..... -0.3 V to (V<sub>CC</sub> + 0.3 V)

#### Short Circuit Duration

T<sub>OUT</sub> ..... Continuous

#### Thermal Impedance, θ<sub>JA</sub>

CP-32 LFCSP ..... 32.5°C/W

RU-28 TSSOP ..... 68.0°C/W

RU-24 TSSOP ..... 68.0°C/W

RS-28 SSOP ..... 76.0°C/W

#### Operating Temperature Range

Industrial (A Version) ..... -40°C to +85°C

Storage Temperature Range ..... -65°C to +150°C

Lead Temperature (Soldering, 10 sec) ..... 300°C

ESD Rating (IEC 1000-4-2 Air) (RS-232 I/Os) ..... ±15 kV

ESD Rating (IEC 1000-4-2 Contact) (RS-232 I/Os) ..... ±8 kV

\*This is a stress rating only and functional operation of the device at these or any other conditions above those indicated in the operation sections of this specification is not implied. Exposure to absolute maximum rating conditions for extended periods of time may affect reliability.

## PRODUCT SELECTION GUIDE

Generic Voltage	Supply	Tx	Rx	No. Rx Active in SD	Speed	15 kV ESD	I <sub>CC</sub> Max	I <sub>CC</sub> Shutdown Max*	Additional Features
ADM3307E	2.7 V to 3.6 V	5	3	1	1 Mbps	RS-232 CMOS $\overline{EN}$ and SD	1.5 mA	1 $\mu$ A	$\pm$ 15 kV ESD Protection CMOS on RS-232 and CMOS I/Os Including SD and $\overline{EN}$ Pins. 2 Rx's Active in Shutdown. Green Idle Mode Level 6 V. Low power ADM3311E.  22 k $\Omega$ Rx I/P Resistance. Green Idle Mode Level 6 V. Low power ADM3312E.
ADM3310E	2.7 V to 3.6 V	3	5	2	460 kbps	RS-232	0.85 mA	1 $\mu$ A	
ADM3311E	2.7 V to 3.6 V	3	5	1	460 kbps	RS-232	1 mA	1 $\mu$ A	
ADM3312E	2.7 V to 3.6 V	3	3	1	460 kbps	RS-232	1 mA	1 $\mu$ A	
ADM3315E	2.7 V to 3.6 V	3	3	1	460 kbps	RS-232	0.85 mA	1 $\mu$ A	

\*I<sub>CC</sub> Shutdown is 20 nA typically.

## ORDERING GUIDE

Model	Temperature Range	Package Description	Package Option
ADM3307EARU	-40°C to +85°C	28-Lead Thin Shrink Small Outline (TSSOP)	RU-28
ADM3307EACP	-40°C to +85°C	32-Lead 5 mm $\times$ 5 mm Lead Frame Chip Scale Package (LFCSP)	CP-32
ADM3310EARU	-40°C to +85°C	28-Lead Thin Shrink Small Outline (TSSOP)	RU-28
ADM3310EACP	-40°C to +85°C	32-Lead 5 mm $\times$ 5 mm Lead Frame Chip Scale Package (LFCSP)	CP-32
ADM3311EARS	-40°C to +85°C	28-Lead Shrink Small Outline (SSOP)	RS-28
ADM3311EARU	-40°C to +85°C	28-Lead Thin Shrink Small Outline (TSSOP)	RU-28
ADM3311EACP	-40°C to +85°C	32-Lead 5 mm $\times$ 5 mm Lead Frame Chip Scale Package (LFCSP)	CP-32
ADM3312EARU	-40°C to +85°C	24-Lead Thin Shrink Small Outline (TSSOP)	RU-24
ADM3312EACP	-40°C to +85°C	32-Lead 5 mm $\times$ 5 mm Lead Frame Chip Scale Package (LFCSP)	CP-32
ADM3315EARU	-40°C to +85°C	24-Lead Thin Shrink Small Outline (TSSOP)	RU-24
ADM3315EACP	-40°C to +85°C	32-Lead 5 mm $\times$ 5 mm Lead Frame Chip Scale Package (LFCSP)	CP-32

### CAUTION

ESD (electrostatic discharge) sensitive device. Electrostatic charges as high as 4000 V readily accumulate on the human body and test equipment and can discharge without detection. Although the ADM33xxE features proprietary ESD protection circuitry, permanent damage may occur on devices subjected to high energy electrostatic discharges. Therefore, proper ESD precautions are recommended to avoid performance degradation or loss of functionality.



# ADM33xxE

## PIN CONFIGURATIONS

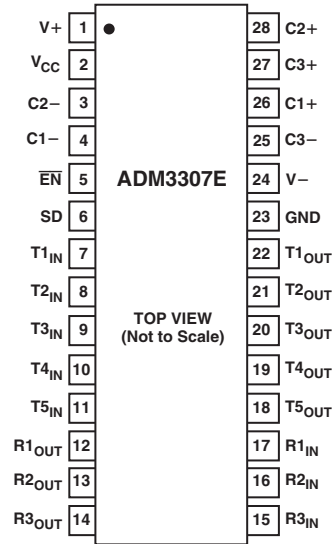
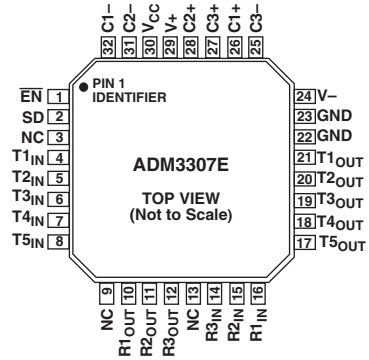

ADM3307E

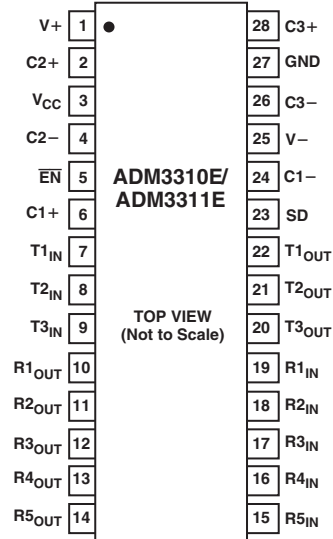
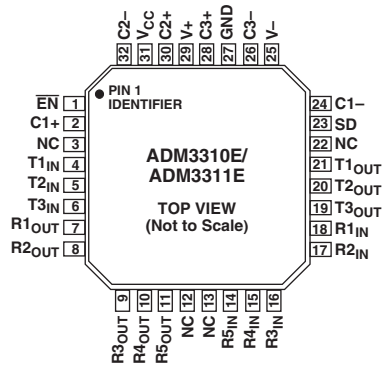

ADM3310E/ADM3311E

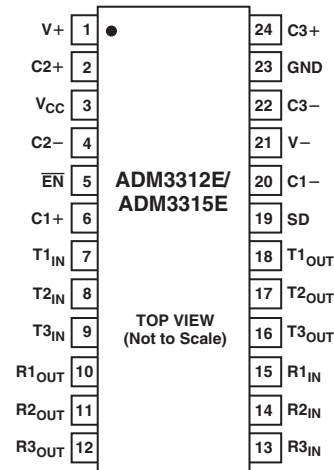
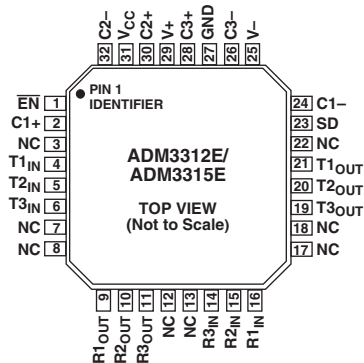

ADM3312E/ADM3315E

## PIN FUNCTION DESCRIPTION

Mnemonic	Function
V <sub>CC</sub>	Power Supply Input 2.7 V to 3.6 V
V+	Internally generated positive supply 7.25 V (6.5 V nominal for ADM3310E, ADM3315E). Capacitor C4 is connected between V <sub>CC</sub> and V+.
V-	Internally generated positive supply -7.25 V (-6.5 V nominal for ADM3310E, ADM3315E). Capacitor C5 is connected between GND and V-.
GND	Ground Pin. Must be connected to 0 V.
C1+, C1-	External Capacitor 1 is connected between these pins. A 0.1 μF capacitor is recommended but larger capacitors up to 1 μF may be used.
C2+, C2-	External Capacitor 2 is connected between these pins. A 0.1 μF capacitor is recommended but larger capacitors up to 1 μF may be used.
C3+, C3-	External Capacitor 3 is connected between these pins. A 0.1 μF capacitor is recommended but larger capacitors up to 1 μF may be used.
T <sub>IN</sub>	Transmitter (Driver) Inputs. These inputs accept TTL/CMOS levels. An internal 400 kΩ pull-up resistor to V <sub>CC</sub> is connected on each input.
T <sub>OUT</sub>	Transmitter (Driver) Outputs. Typically ±5.5 V (±6.4 V for ADM3311E and ADM3312E)
R <sub>IN</sub>	Receiver Inputs. These inputs accept RS-232 signal levels. An internal 5 kΩ pull-down resistor (22 kΩ for ADM3315E) to GND is connected on each of these inputs.
R <sub>OUT</sub>	Receiver Outputs. These are TTL/CMOS levels.
$\overline{\text{EN}}$	Receiver Enable. A high level three-states all the receiver outputs.
SD	Shutdown Control. A high level will disable the charge pump and reduce the quiescent current to less than 1 μA. All transmitters and most receivers are disabled. One receiver remains active in shutdown (two receivers active in shutdown for the ADM3310E). <ul style="list-style-type: none"> <li>• ADM3307E R<sub>OUT3</sub> active in shutdown</li> <li>• ADM3310E R<sub>OUT4</sub> and R<sub>OUT5</sub> active in shutdown</li> <li>• ADM3311E R<sub>OUT5</sub> active in shutdown</li> <li>• ADM3312E R<sub>OUT3</sub> active in shutdown</li> <li>• ADM3315E R<sub>OUT3</sub> active in shutdown</li> </ul>

**Table I. ADM3307E Truth Table**

SD	$\overline{\text{EN}}$	Status	T <sub>OUT1-5</sub>	R <sub>OUT1-2</sub>	R <sub>OUT3</sub>
0	0	Normal Operation	Enabled	Enabled	Enabled
0	1	Normal Operation	Enabled	Disabled	Disabled
1	0	Shutdown	Disabled	Disabled	Enabled
1	1	Shutdown	Disabled	Disabled	Disabled

**Table II. ADM3310E Truth Table**

SD	$\overline{\text{EN}}$	Status	T <sub>OUT1-3</sub>	R <sub>OUT1-3</sub>	R <sub>OUT4-5</sub>
0	0	Normal Operation	Enabled	Enabled	Enabled
0	1	Receivers Disabled	Enabled	Disabled	Disabled
1	0	Shutdown	Disabled	Disabled	Enabled
1	1	Shutdown	Disabled	Disabled	Disabled

**Table III. ADM3311 Truth Table**

SD	$\overline{\text{EN}}$	Status	T <sub>OUT1-3</sub>	R <sub>OUT1-4</sub>	R <sub>OUT5</sub>
0	0	Normal Operation	Enabled	Enabled	Enabled
0	1	Receivers Disabled	Enabled	Disabled	Disabled
1	0	Shutdown	Disabled	Disabled	Enabled
1	1	Shutdown	Disabled	Disabled	Disabled

**Table IV. ADM3312E/ADM3315E Truth Table**

SD	$\overline{\text{EN}}$	Status	T <sub>OUT1-3</sub>	R <sub>OUT1-2</sub>	R <sub>OUT3</sub>
0	0	Normal Operation	Enabled	Enabled	Enabled
0	1	Normal Operation	Enabled	Disabled	Disabled
1	0	Shutdown	Disabled	Disabled	Enabled
1	1	Shutdown	Disabled	Disabled	Disabled

# ADM33xxE—Typical Performance Characteristics

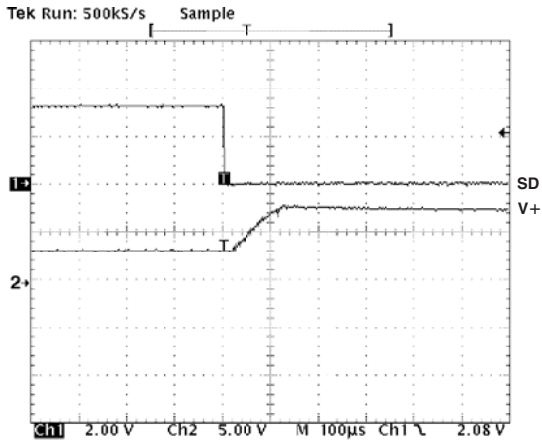

TPC 1. Charge Pump V+ Exiting Shutdown

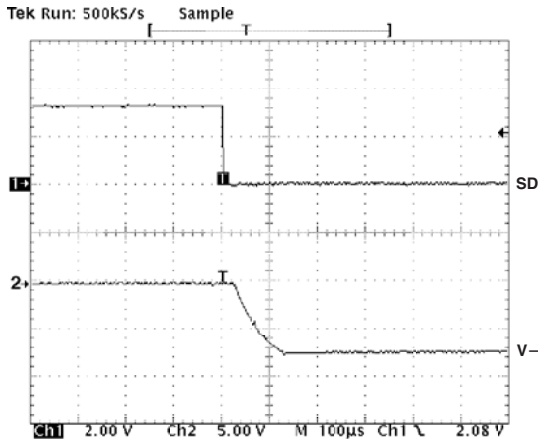

TPC 2. Charge Pump V- Exiting Shutdown

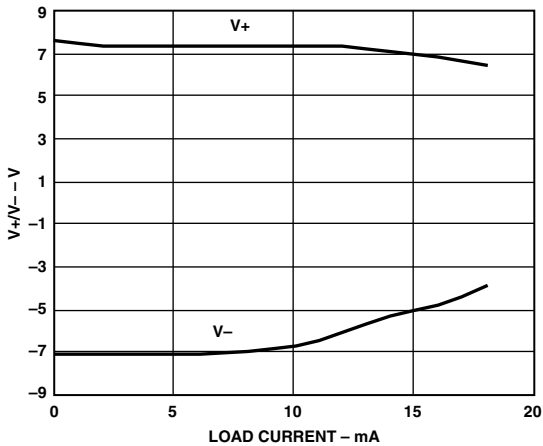

TPC 3. Charge Pump V+, V- vs. Load Current ( $V_{CC} = 3.3\text{ V}$ )

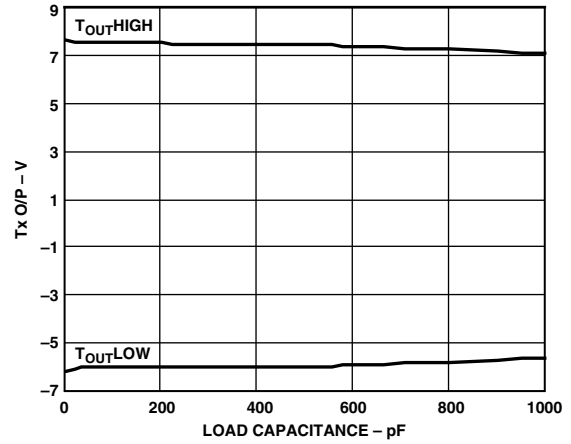

TPC 4. Transmitter Output vs. Load Capacitance ( $V_{CC} = 3.3\text{ V}$ , Data Rate = 460 kbps)

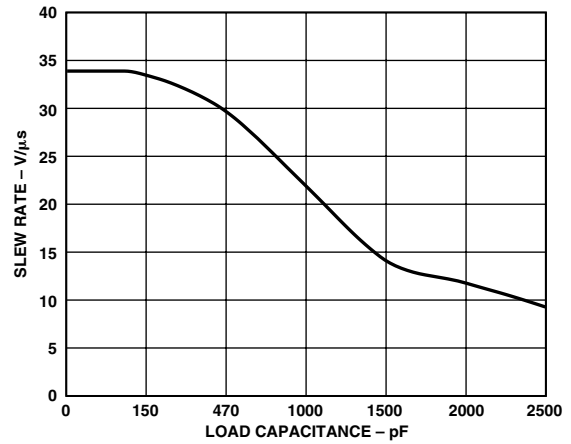

TPC 5. Slew Rate vs. Load Capacitance ( $V_{CC} = 3.3\text{ V}$ )

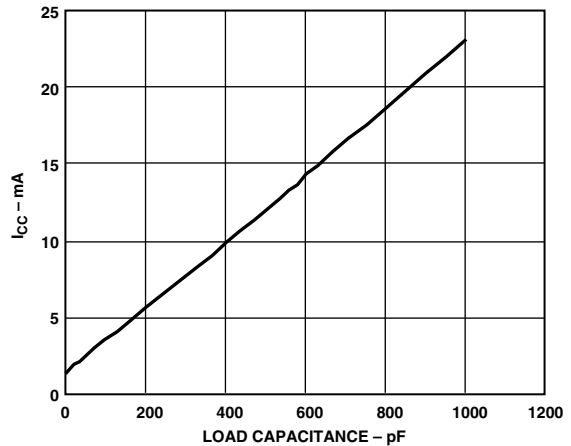

TPC 6. Supply Current vs. Load Capacitance ( $R_L = 3\text{ k}\Omega$ ,  $V_{CC} = 3.3\text{ V}$ , Data Rate = 460 kbps)



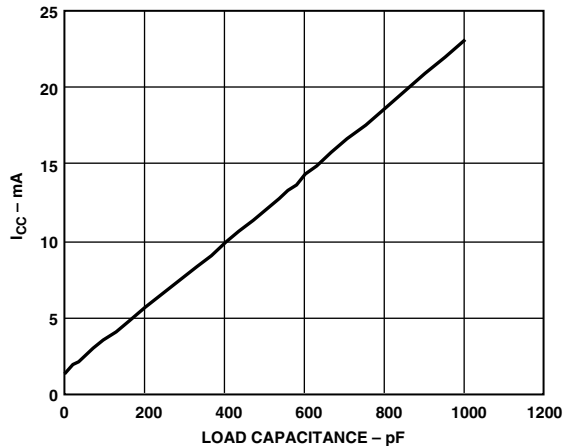

TCP 7. Supply Current vs. Load Capacitance ( $R_L = \text{Infinite}$ ) ( $V_{CC} = 3.3 \text{ V}$ , Data Rate = 460 kbps)

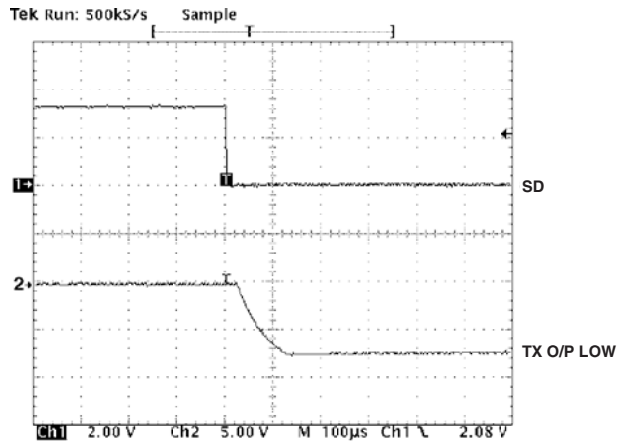

TPC 10. Transmitter Output (Low) Exiting Shutdown

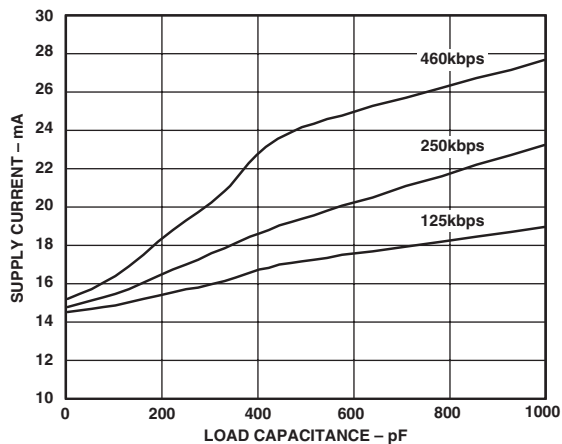

TPC 8. Supply Current vs. Load Capacitance ( $V_{CC} = 3.3 \text{ V}$ ,  $R_L = 5 \text{ k}\Omega$ )

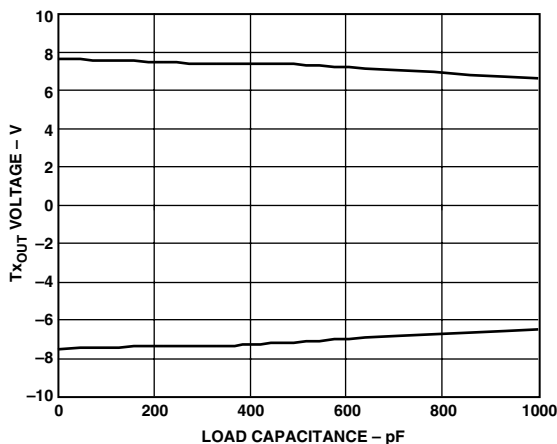

TPC 11. Transmitter Output Voltage High/Low vs. Load Capacitance ( $V_{CC} = 3.3 \text{ V}$ ,  $\text{CLK} = 1 \text{ Mb/s}$ ,  $R_L = 5 \text{ k}\Omega$ , ADM3307E)

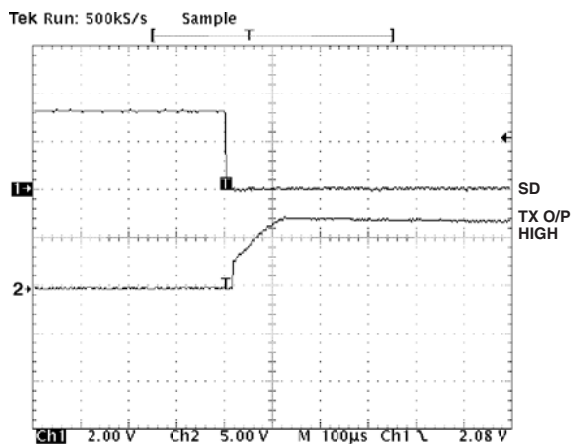

TPC 9. Transmitter Output (High) Exiting Shutdown

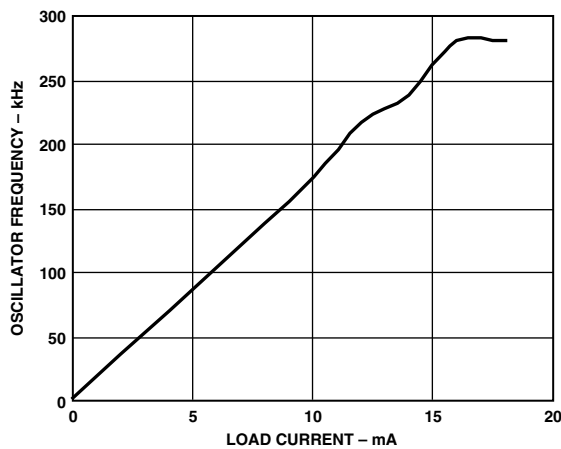

TPC 12. Oscillator Frequency vs. Load Current

# ADM33xxE

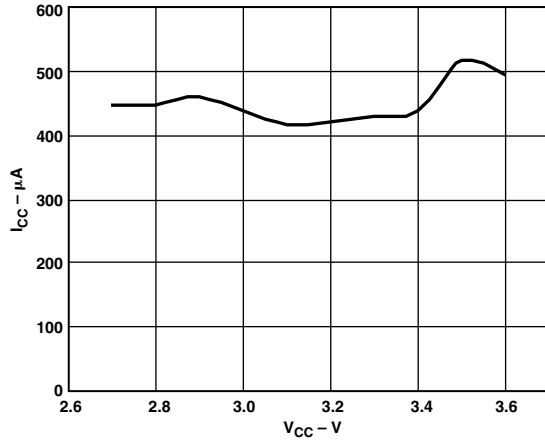

TCP 13.  $I_{CC}$  vs.  $V_{CC}$  (Unloaded)

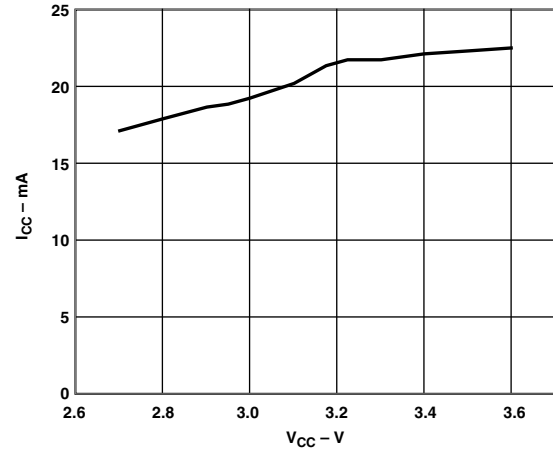

TPC 14.  $I_{CC}$  vs.  $V_{CC}$  ( $R_L = 3 k\Omega$ )

## CIRCUIT DESCRIPTION

The internal circuitry consists mainly of four sections. These include the following:

1. A charge pump voltage converter
2. 3.3 V logic to EIA-232 transmitters
3. EIA-232 to 3.3 V logic receivers
4. Transient protection circuit on all I/O lines

### Charge Pump DC-to-DC Voltage Converter

The charge pump voltage converter consists of a 250 kHz (300 kHz for ADM3307E) oscillator and a switching matrix. The converter generates a  $\pm 9$  V supply from the input 3.0 V level. This is done in two stages using a switched capacitor technique, as illustrated. First, the 3.0 V input supply is tripled to 9.0 V using capacitor C4 as the charge storage element. The +9.0 V level is then inverted to generate  $-9.0$  V using C5 as the storage element.

However, it should be noted that, unlike other charge pump dc-to-dc converters, the charge pump on the ADM3307E does not run open-loop. The output voltage is regulated to  $\pm 7.25$  V (or  $\pm 6.5$  V for the ADM3310E and ADM3315E) by the Green Idle circuit and will never reach  $\pm 9$  V in practice. This saves power as well as maintains a more constant output voltage.

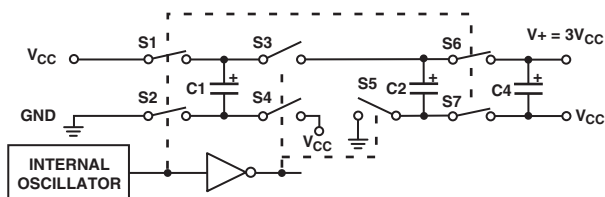

Figure 1. Charge Pump Voltage Tripler

The tripler operates in two phases. During the oscillator low phase, S1 and S2 are closed and C1 charges rapidly to  $V_{CC}$ . S3, S4, and S5 are open, and S6 and S7 are closed.

During the oscillator high phase, S1 and S2 are open, and S3 and S4 are closed, so the voltage at the output of S3 is  $2 V_{CC}$ . This voltage is used to charge C2. In the absence of any discharge current, C2 will charge up to  $2 V_{CC}$  after several cycles. During the oscillator high phase, as previously mentioned, S6 and S7 are closed, so the voltage at the output of S6 will be  $3 V_{CC}$ . This voltage is then used to charge C3. The voltage inverter is illustrated in Figure 2.

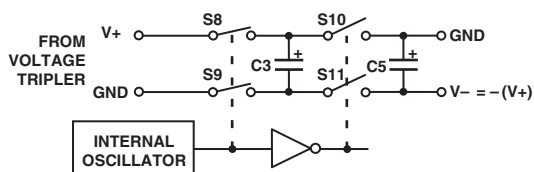

Figure 2. Charge Pump Voltage Inverter

During the oscillator high phase, S10 and S11 are open, while S8 and S9 are closed. C3 is charged to  $3 V_{CC}$  from the output of the voltage tripler over several cycles. During the oscillator low phase, S8 and S9 are open, while S10 and S11 are closed. C3 is connected across C5, whose positive terminal is grounded and whose negative terminal is the  $V^-$  output. Over several cycles, C5 charges to  $-3 V_{CC}$ .

The  $V^+$  and  $V^-$  supplies may also be used to power external circuitry if the current requirements are small. Please refer to TPC 3 in the Typical Performance Characteristics section.

### What Is Green Idle?

Green Idle is a method of minimizing power consumption under idle (no transmit) conditions while still maintaining the ability to transmit data instantly.

### How Does it Work?

Charge pump type dc-to-dc converters used in RS-232 line drivers normally operate open-loop, i.e., the output voltage is not regulated in any way. Under light load conditions, the output voltage is close to twice the supply voltage for a doubler and three times the supply voltage for a tripler, with very little ripple. As the load current increases, the output voltage falls and the ripple voltage increases.

Even under no-load conditions, the oscillator and charge pump operate at a very high frequency with consequent switching losses and current drain.

Green Idle works by monitoring the output voltage and maintaining it at a constant value of around  $7 V^*$ . When the voltage rises above  $7.25 V^{**}$  the oscillator is turned off. When the voltage falls below  $7 V^*$ , the oscillator is turned on and a burst of charging pulses is sent to the reservoir capacitor. When the oscillator is turned off, the power consumption of the charge pump is virtually zero, so the average current drain under light load conditions is greatly reduced.

A block diagram of the Green Idle circuit is shown in Figure 3. Both  $V^+$  and  $V^-$  are monitored and compared to a reference voltage derived from an on-chip band gap device. If either  $V^+$  or  $V^-$  fall below  $7 V^*$ , the oscillator will start up until the voltage rises above  $7.25 V^{**}$ .

#### NOTES

\*For ADM3310E and ADM3315E, replace with 6.25 V.

\*\*For ADM3310E and ADM3315E, replace with 6.5 V.

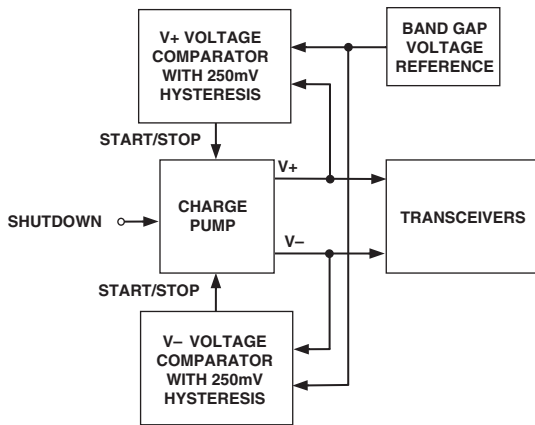
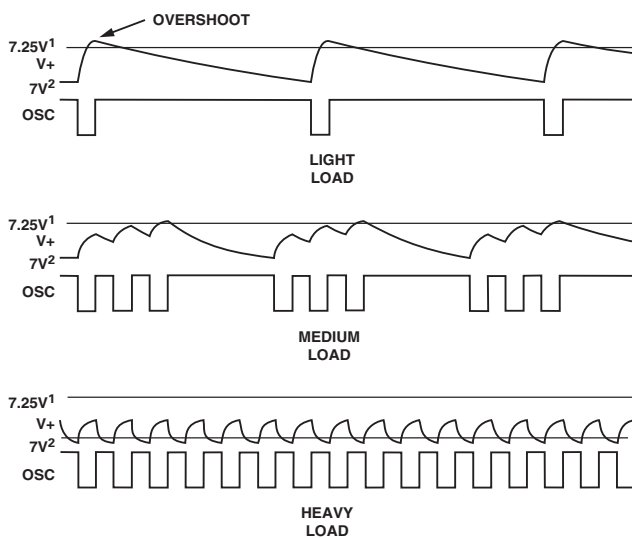

Figure 3. Block Diagram of Green Idle Circuit

The operation of Green Idle for V+ under various load conditions is illustrated in Figure 4. Under light load conditions, C1 is maintained in a charged condition and only a single oscillator pulse will be required to charge up C2. Under these conditions, V+ may actually overshoot 7.25 V\*\* slightly.



- NOTES  
 1. FOR ADM3310E AND ADM3315E REPLACE WITH 6.5 V.  
 2. FOR ADM3310E AND ADM3315E REPLACE WITH 6.25 V.

Figure 4. Operation of Green Idle Under Various Load Conditions

Under medium load conditions, it may take several cycles for C2 to charge up to 7.25 V\*\*. The average frequency of the oscillator will be higher because there are more pulses in each burst and the bursts of pulses are closer together and more frequent.

Under high load conditions, the oscillator will be on continuously if the charge pump output cannot reach 7.25 V\*\*.

### Green Idle Versus Shutdown

Shutdown Mode minimizes power consumption by shutting down the charge pump altogether. In this mode, the switches in the voltage tripler are configured so that V+ is connected directly to V<sub>CC</sub>. V- is zero because there is no charge pump operation to charge C5. This means that there is a delay when coming out of Shutdown Mode before V+ and V- achieve their normal operating voltages. Green

Idle maintains the transmitter supply voltages under transmitter idle conditions so this delay does not occur.

### Doesn't It Increase Supply Voltage Ripple?

The ripple on the output voltage of a charge pump operating in open-loop depends on three factors: the oscillator frequency, the value of the reservoir capacitor, and the load current. The value of the reservoir capacitor is fixed. Increasing the oscillator frequency will decrease the ripple voltage; decreasing the oscillator frequency will increase it. Increasing the load current will increase the ripple voltage; decreasing the load current will decrease it. The ripple voltage at light loads will naturally be lower than that for high load currents.

Using Green Idle, the ripple voltage is determined by the high and low thresholds of the Green Idle circuit. These are nominally 7 V\* and 7.25 V\*\*, so the ripple will be 250 mV under most load conditions. With very light load conditions, there may be some overshoot above 7.25 V\*\*, so the ripple will be slightly greater. Under heavy load conditions where the output never reaches 7.25 V\*\*, the Green Idle circuit will be inoperative and the ripple voltage will be determined by the load current, the same as in a normal charge pump.

### What About Electromagnetic Compatibility?

Green Idle does not operate with a constant oscillator frequency. As a result, the frequency and spectrum of the oscillator signal will vary with load. Any radiated and conducted emissions will also vary accordingly. Like other Analog Devices RS-232 transceiver products, the ADM33xxE devices feature slew rate limiting and other techniques to minimize radiated and conducted emissions.

### Transmitter (Driver) Section

The drivers convert 3.3 V logic input levels into EIA-232 output levels. With V<sub>CC</sub> = 3.0 V and driving an EIA-232 load, the output voltage swing is typically ±6.4 V (or ±5.5 V for ADM3310E and ADM3315E).

Unused inputs may be left unconnected, as an internal 400 kΩ pull-up resistor pulls them high forcing the outputs into a low state. The input pull-up resistors typically source 8 mA when grounded, so unused inputs should either be connected to V<sub>CC</sub> or left unconnected in order to minimize power consumption.

### Receiver Section

The receivers are inverting level shifters that accept RS-232 input levels and translate them into 3.3 V logic output levels. The inputs have internal 5 kΩ pull-down resistors (22 kΩ for the ADM3310E) to ground and are also protected against overvoltages of up to ±30 V. Unconnected inputs are pulled to 0 V by the internal 5 kΩ (or 22 kΩ for the ADM3315E) pull-down resistor. This, therefore, results in a Logic 1 output level for unconnected inputs or for inputs connected to GND.

The receivers have Schmitt trigger inputs with a hysteresis level of 0.14 V. This ensures error-free reception for both noisy inputs and for inputs with slow transition times.

### ENABLE AND SHUTDOWN

The enable function is intended to facilitate databus connections where it is desirable to three-state the receiver outputs. In the disabled mode, all receiver outputs are placed in a high impedance state. The shutdown function is intended to shut the device down, thereby minimizing the quiescent current. In shutdown, all transmitters are disabled. All receivers are shut down, except for receiver R3 (ADM3307E, ADM3312E, and ADM3315E), receiver R5 (ADM3311E), and receivers R4 and R5 (ADM3310E).

### NOTES

- \*For ADM3310E and ADM3315E, replace with 6.25 V.  
 \*\*For ADM3310E and ADM3315E, replace with 6.5 V.

Note that disabled transmitters are not three-stated in shutdown, so it is not permitted to connect multiple (RS-232) driver outputs together.

The shutdown feature is very useful in battery-operated systems since it reduces the power consumption to 66 nW. During shutdown, the charge pump is also disabled. When exiting shutdown, the charge pump is restarted and it takes approximately 100  $\mu$ s for it to reach its steady state operating conditions.

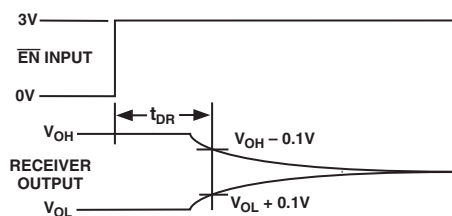

Figure 5. Receiver Disable Timing

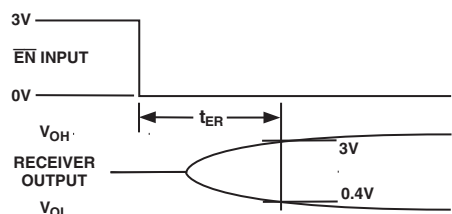

Figure 6. Receiver Enable Timing

### High Baud Rate

The ADM33xxE features high slew rates permitting data transmission at rates well in excess of the EIA/RS-232E specifications. RS-232 voltage levels are maintained at data rates up to 230 kbps (460 kbps for ADM3307E) under worst-case loading conditions. This allows for high speed data links between two terminals.

### LAYOUT AND SUPPLY DECOUPLING

Because of the high frequencies at which the ADM33xxE oscillator operates, particular care should be taken with printed circuit board layout, with all traces being as short as possible and C1 to C3 being connected as close to the device as possible. The use of a ground plane under and around the device is also highly recommended.

When the oscillator starts up during Green Idle operation, large current pulses are taken from  $V_{CC}$ . For this reason,  $V_{CC}$  should be decoupled with a parallel combination of 10  $\mu$ F tantalum and 0.1  $\mu$ F ceramic capacitors, mounted as close to the  $V_{CC}$  Pin as possible.

Capacitors C1 to C3 can have values between 0.1  $\mu$ F and 1  $\mu$ F. Larger values will give lower ripple. These capacitors can be either electrolytic capacitors chosen for low equivalent series resistance (ESR) or nonpolarized types, but the use of ceramic types is highly recommended. If polarized electrolytic capacitors are used, then polarity must be observed (as shown by C1+).

### ESD/EFT TRANSIENT PROTECTION SCHEME

The ADM33xxE uses protective clamping structures on all inputs and outputs that clamp the voltage to a safe level and dissipate the energy present in ESD (electrostatic) and EFT (electrical fast transients) discharges. A simplified schematic of the protection structure is shown below in Figures 7a and 7b (see Figures 8a and 8b for ADM3307E protection structure). Each input and output

contains two back-to-back high speed clamping diodes. During normal operation with maximum RS-232 signal levels, the diodes have no effect as one or the other is reverse biased depending on the polarity of the signal. If however the voltage exceeds about  $\pm 50$  V, reverse breakdown occurs and the voltage is clamped at this level. The diodes are large p-n junctions that are designed to handle the instantaneous current surge that can exceed several amperes.

The transmitter outputs and receiver inputs have a similar protection structure. The receiver inputs can also dissipate some of the energy through the internal 5 k $\Omega$  (or 22 k $\Omega$  for the ADM3310E) resistor to GND as well as through the protection diodes.

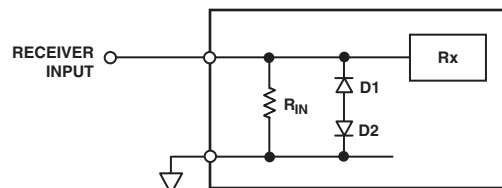

Figure 7a. Receiver Input Protection Scheme

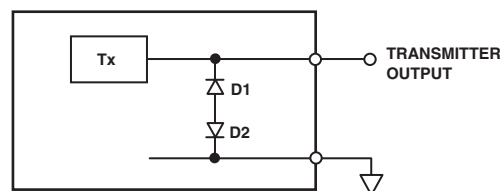

Figure 7b. Transmitter Output Protection Scheme

The ADM3307E protection scheme is slightly different (see Figures 8a and 8b). The receiver inputs, transmitter inputs, and transmitter outputs contain two back-to-back high speed clamping diodes. The receiver outputs (CMOS outputs), SD and  $\overline{EN}$  Pins contain a single reverse biased high speed clamping diode. Under normal operation with maximum CMOS signal levels, the receiver output, SD, and  $\overline{EN}$  protection diodes have no effect because they are reverse biased. If, however, the voltage exceeds about 15 V, reverse breakdown occurs and the voltage is clamped at this level. If the voltage reaches  $-0.7$  V, the diode is forward biased and the voltage is clamped at this level. The receiver inputs can also dissipate some of the energy through the internal 5 k $\Omega$  resistor to GND as well as through the protection diodes.

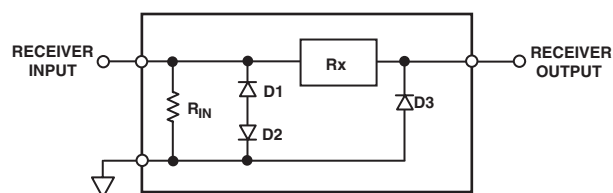

Figure 8a. ADM3307E Receiver Input Protection Scheme

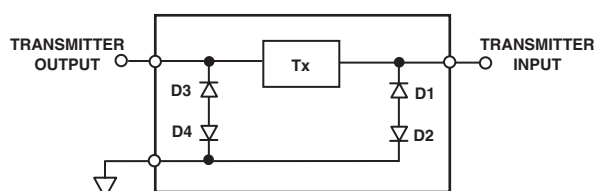

Figure 8b. ADM3307E Transmitter Output Protection Scheme

# ADM33xxE

The protection structures achieve ESD protection up to  $\pm 15$  kV on all RS-232 I/O lines (and all CMOS lines, including SD and EN for the ADM3307E). The methods used to test the protection scheme are discussed later.

## ESD TESTING (IEC 1000-4-2)

IEC 1000-4-2 (previously 801-2) specifies compliance testing using two coupling methods, contact discharge and air-gap discharge. Contact discharge calls for a direct connection to the unit being tested. Air-gap discharge uses a higher test voltage but does not make direct contact with the unit under testing. With air discharge, the discharge gun is moved toward the unit under testing, which develops an arc across the air gap, hence the term air discharge. This method is influenced by humidity, temperature, barometric pressure, distance, and rate of closure of the discharge gun. The contact discharge method, while less realistic, is more repeatable and is gaining acceptance in preference to the air-gap method.

Although very little energy is contained within an ESD pulse, the extremely fast rise time coupled with high voltages can cause failures in unprotected semiconductors. Catastrophic destruction can occur immediately as a result of arcing or heating. Even if catastrophic failure does not occur immediately, the device may suffer from parametric degradation that may result in degraded performance. The cumulative effects of continuous exposure can eventually lead to complete failure.

I/O lines are particularly vulnerable to ESD damage. Simply touching or plugging in an I/O cable can result in a static discharge that can damage or completely destroy the interface product connected to the I/O port. Traditional ESD test methods, such as the MIL-STD-883B method 3015.7, do not fully test a product's susceptibility to this type of discharge. This test was intended to test a product's susceptibility to ESD damage during handling. Each pin is tested with respect to all other pins. There are some important differences between the traditional test and the IEC test:

- (a) The IEC test is much more stringent in terms of discharge energy. The peak current injected is over four times greater.
- (b) The current rise time is significantly faster in the IEC test.
- (c) The IEC test is carried out while power is applied to the device.

It is possible that the ESD discharge could induce latch-up in the device under test. This test, therefore, is more representative of a real world I/O discharge where the equipment is operating normally with power applied. For maximum peace of mind however, both tests should be performed, ensuring maximum protection both during handling and later during field service.

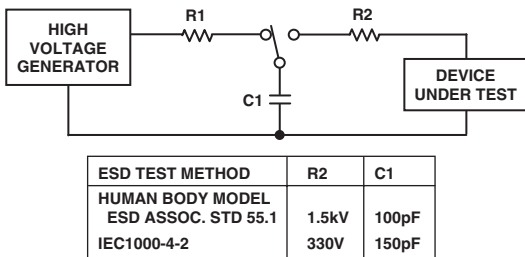

Figure 9. ESD Test Standards

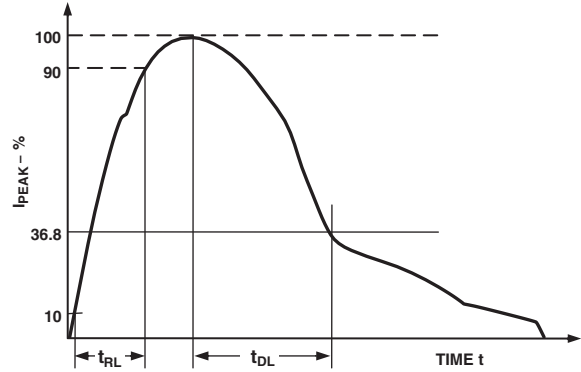

Figure 10. Human Body Model ESD Current Waveform

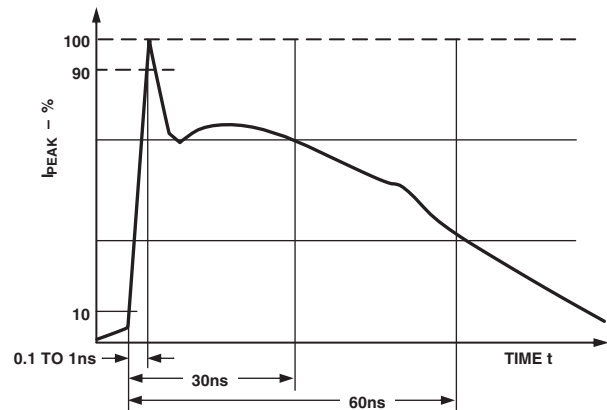

Figure 11. IEC1000-4-2 ESD Current Waveform

The ADM33xxE devices are tested using both of the above mentioned test methods. All pins are tested with respect to all other pins as per the Human Body Model, ESD Assoc. Std. 55.1 specification. In addition, all I/O pins are tested as per the IEC 1000-4-2 test specification. The products were tested under the following conditions:

- (a) Power-On—Normal Operation
- (b) Power-Off

There are four levels of compliance defined by IEC 1000-4-2. The ADM33xxE parts meet the most stringent compliance level for both contact and air-gap discharge. This means that the products are able to withstand contact discharges in excess of 8 kV and air-gap discharges in excess of 15 kV.

Table V. IEC 1000-4-2 Compliance Levels

Level	Contact Discharge (kV)	Air Discharge (kV)
1	2	2
2	4	4
3	6	8
4	8	15

**OUTLINE DIMENSIONS**  
**32-Lead Frame Chip Scale Package [LFCSP]**  
**(CP-32)**

Dimensions shown in millimeters

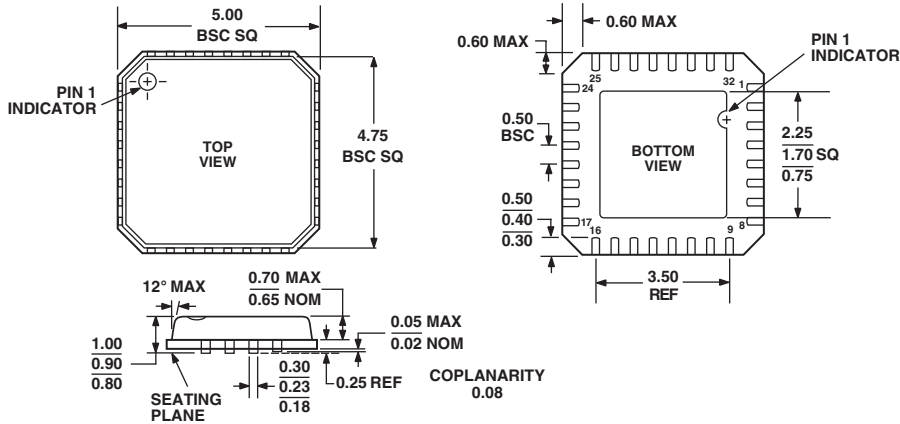

COMPLIANT TO JEDEC STANDARDS MO-220-VHHD-2

**28-Lead Shrink Small Outline Package [SSOP]**  
**(RS-28)**

Dimensions shown in millimeters

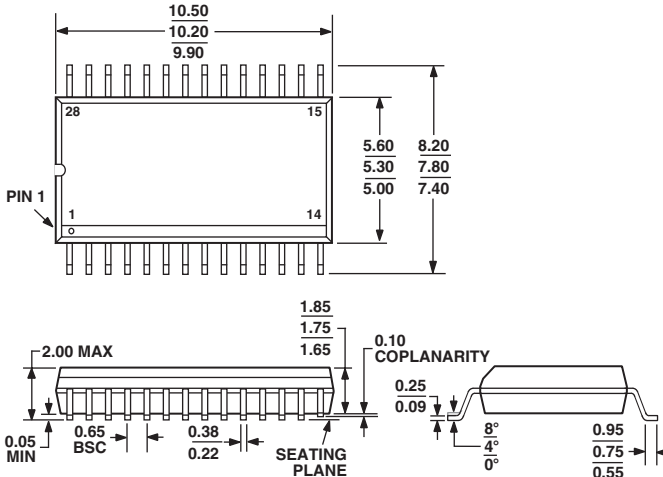

COMPLIANT TO JEDEC STANDARDS MO-150AH

**24-Lead Thin Shrink Small Outline Package [TSSOP]**  
**(RU-24)**

Dimensions shown in millimeters

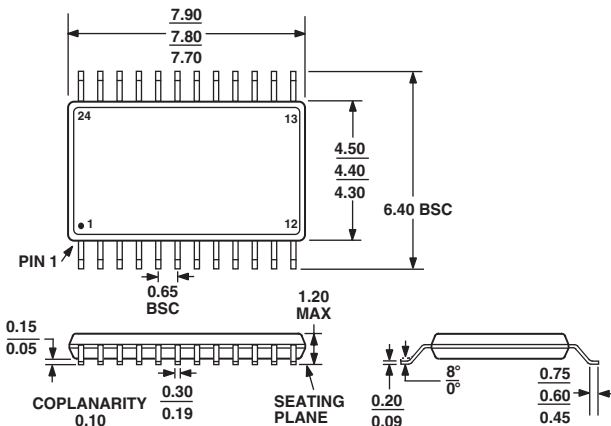

COMPLIANT TO JEDEC STANDARDS MO-153AD

**28-Lead Thin Shrink Small Outline Package [TSSOP]**  
**(RU-28)**

Dimensions shown in millimeters

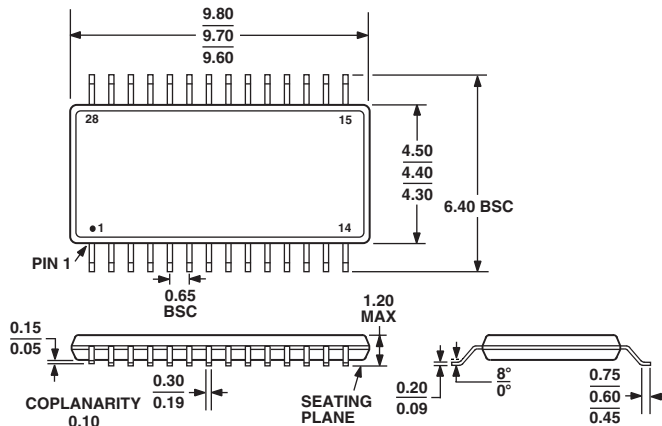

COMPLIANT TO JEDEC STANDARDS MO-153AE

# ADM33xxE

## Revision History

Location	Page
<b>8/02—Data Sheet changed to REV. F</b>	
ADM3307E (REV. 0), ADM3311E (REV. E), and ADM3312E (REV. A) data sheets merged into Rev. F of ADM33xxE	UNIVERSAL
ADM3310E (REV. PrA now prelims) and ADM3315E (REV. PrA) added	UNIVERSAL
Edits to FEATURES	1
Edits to APPLICATIONS	1
Edits to GENERAL DESCRIPTION	1
Edits to FUNCTIONAL BLOCK DIAGRAMS	2
Edits to SPECIFICATIONS	3
Edits to ABSOLUTE MAXIMUM RATINGS	4
ADM33xx PRODUCT SELECTION GUIDE added	5
Added ADM3307E, ADM3310E, ADM3312E, and ADM3315E PIN CONFIGURATIONS	6
Edits to PIN FUNCTION DESCRIPTION	7
Added ADM3307E, ADM3310E, ADM3312E, and ADM3315E Truth Tables	7
Edits to TPCs 1–14	8
TPCs 15–18 deleted	10
Edits to CIRCUIT DESCRIPTION section	11
Edits to Charge Pump DC-to-DC Voltage Converter section	11
Edits to How Does It Work section	11
Edits to Green Idle vs. Shutdown section	12
Edits to Doesn't It Increase Supply Voltage Ripple? section	12
Edits to What About Electromagnetic Compatibility? section	12
Edits to Transmitter (Driver) section	12
Edits to Receiver section	12
Edits to ENABLE AND SHUTDOWN section	12
Edits to High Baud Rate section	13
Edits to ESD/EFT TRANSIENT PROTECTION SCHEME	13
Added Figures 8a and 8b and renumbered the figures that followed	13
Edits to ESD TESTING (IEC 1000-4-2) section	14
Edits to Figure 9	14
Deleted Table II and Table III and replaced them with Table V	14
Added RU-24 PACKAGE OUTLINE; updated CP-32, RS-28 and RU-28	15

C02915-0-8/02(F)

PRINTED IN U.S.A.