

FEATURES

Analog Input Block

- 11-Bit Resolution Analog-to-Digital (A/D) Converter
- 7 Single-Ended (SE) Analog Inputs
 - 4 Simultaneously Sampled Analog Inputs
 - Expansion with 4 Multiplexed Inputs
- 3.2 μ s Conversion Time/Channel
- 0 V–5 V Analog Input Range
- Internal 2.5 V Reference
- PWM Synchronized Sampling Capability

12-Bit PWM Timer Block

- Three-Phase Center-Based PWM
- 1.5 kHz–25 kHz PWM Switching Frequency Range
- Programmable Deadtime
- Programmable Pulse Deletion
- PWM Synchronized Output
- External PWM Shutdown

Vector Transformation Block

- 12-Bit Vector Transformations
- Forward and Reverse Clarke Transformations
- Forward and Reverse Park Rotations
- 2.9 μ s Transformation Time

Programmable Digital I/O Port

- 6 Bit Configurable Digital I/O
- Change of State Interrupt Support

DSP & Microcontroller Interface

- 12 Bit Memory Mapped Registers
- Twos Complement Data Format
- 6.25 MHz to 25 MHz Operating Clock Range

68-Pin PLCC Package

- Single 5 V DC Power Supply
- Industrial Temperature Range

GENERAL DESCRIPTION

The ADCM201 is a motion coprocessor that can be used with either microcontrollers or digital signal processors (DSP). It provides the functionality that is required to implement a digital control system. In a typical application, the DSP or microcontroller performs the control algorithms (position, speed, torque and flux loops) and the ADCM201 provides the necessary motor control functions: analog current data acquisition, vector transformation, digital inputs/outputs, and PWM drive signals.

PRODUCT HIGHLIGHTS

Simultaneous Sampling of Four Inputs

A four channel sample and hold amplifier allows three-phase motor currents to be sampled simultaneously, reducing errors from phase coherency. Sample and hold acquisition time is 1.6 μ s and conversion time per channel is 3.2 μ s (using a 12.5 MHz system clock).

REV. A

Information furnished by Analog Devices is believed to be accurate and reliable. However, no responsibility is assumed by Analog Devices for its use, nor for any infringements of patents or other rights of third parties which may result from its use. No license is granted by implication or otherwise under any patent or patent rights of Analog Devices.

FUNCTIONAL BLOCK DIAGRAM

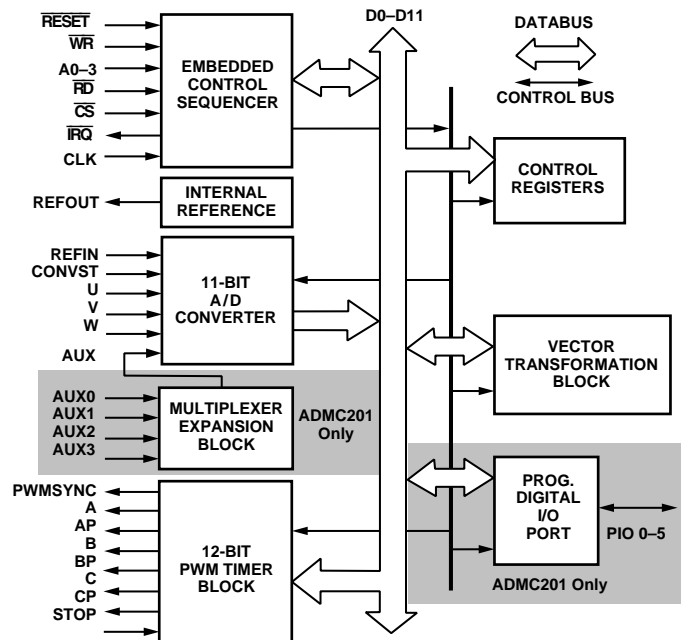

Flexible Analog Channel Sequencing

The ADCM201 supports acquisition of 2, 3, or 4 channels per group. Converted channel results are stored in registers and the data can be read in any order. The sampling and conversion time for two channels is 8 μ s, three channels is 11.2 μ s, and four channels is 14.4 μ s (using a 12.5 MHz system clock).

Embedded Control Sequencer

The embedded control sequencer off-loads the DSP or microprocessor, reducing the instructions required to read analog input channels, control PWM timers and perform vector transformations. This frees the host processor for performing control algorithms.

Fast DSP/Microprocessor Interface

The high speed digital interface allows direct connection to 16-bit digital signal processors and microprocessors. The ADCM201 has 12 bit memory mapped registers with twos complement data format and can be mapped directly into the data memory map of a DSP. This allows for a single instruction read and write interface.

Integration

The ADCM201 integrates a four channel simultaneous sampling analog-to-digital converter, four channel analog multiplexer, analog reference, vector transformation, six digital inputs/outputs, and three-phase PWM timers into a 68-pin PLCC. Integration reduces cost, board space, power consumption, and design and test time.

ADMC201–SPECIFICATIONS

($V_{DD} = +5\text{ V} \pm 5\%$; $AGND = DGND = 0\text{ V}$; $REFIN = 2.5\text{ V}$;
External Clock = 12.5 MHz; $T_A = -40^\circ\text{C}$ to $+85^\circ\text{C}$ unless otherwise noted)

Parameter	ADMC201AP	Units	Conditions/Comments
ANALOG-TO-DIGITAL CONVERTER¹			
Resolution	11	Bits	Twos Complement Data Format
Relative Accuracy	± 2	LSB max	Integral Nonlinearity
Differential Nonlinearity	± 2	LSB max	No Missing Codes Guaranteed
Bias Offset Error	± 5	LSB max	Any Channel
Bias Offset Match	4	LSB max	Between Channels
Full-Scale Error	± 6	LSB max	Any Channel
Full-Scale Error Match	4	LSB max	Between Channels
Conversion Time/Channel	40	System CLK Cycles	
Signal-to-Noise Ratio (SNR) ²	60	dB min	$f_{IN} = 600\text{ Hz}$ Sine Wave, $f_{SAMPLE} = 55\text{ kHz}$, 600 Hz
Channel-to-Channel Isolation			
Two-/Three-Phase Mode	-58	dB max	Sine Wave Applied to Unselected Channels
Three-/Three-Phase Mode	-55	dB max	
ANALOG INPUTS			
Input Voltage Level	0–5	Volts	
Analog Input Current	100	μA max	
Input Capacitance	10	pF typ	
TRACK AND HOLD			
Aperture Delay	200	ns max	Any Channel
Aperture Time Delay Match	20	ns max	Between Channels
SHA Acquisition Time	20	System CLK Cycles	
Droop Rate	5	mV/ms max	
REFERENCE INPUT			
Voltage Level	2.5	V dc	
Reference Input Current	50	μA max	
REFERENCE OUTPUT			
Voltage Level	2.5	Volts	
Voltage Level Tolerance	± 5	% max	Full Load
Drive Capability	± 200	μA max	
LOGIC			
V_{IL}	0.8	V max	
V_{IH}	2.0	V min	
V_{OL}	0.4	V max	$I_{SINK} = 400\ \mu\text{A}$, $V_{DD} = 5\text{ V}$
V_{OH}	4.5	V min	$I_{SOURCE} = 20\ \mu\text{A}$, $V_{DD} = 5\text{ V}$
Input Leakage Current	1	μA max	
Three-State Leakage Current	1	μA max	
Input Capacitance	20	pF typ	
12-BIT PWM TIMERS			
Resolution	12	Bits	
Programmable Deadtime Range	0–10.08	μs	160 ns
Programmable Deadtime Increments	2	System CLK Cycles	
Programmable Pulse Deletion Range	0–10.16	μs	
Programmable Deletion Increments	1	System CLK Cycle	80 ns
Minimum PWM Frequency	1.5	kHz	Resolution Varies with PWM Switching Frequency (10 MHz Clock: 20 kHz = 9 Bits, 10 kHz = 10 Bits, 5 kHz = 11 Bits, 2.5 kHz = 12 Bits). Higher Frequencies are Available with Lower Resolution
VECTOR TRANSFORMATION			
Radius Error	0.7	% max	Park & Clarke Transformation
Angular Error	30	arc min max	
Reverse Transformation Time	37	System CLK Cycles	
Forward Transformation Time	40	System CLK Cycles	
EXTERNAL CLOCK INPUT			
Range	6.25–25	MHz	If > 12.5 MHz, Then It Is Necessary to Divide Down via SYSCTRL Register
INTERNAL SYSTEM CLOCK			
Range	6.25–12.5	MHz	
POWER SUPPLY CURRENT			
I_{DD}	20	mA max	

NOTES

¹Measurements made with external reference.

²Tested with PWM Switching Frequency of 25 kHz.

Specifications subject to change without notice.

Table I. ADCM201 Timing Specifications ($V_{DD} = 5\text{ V}, \pm 5\%$; $T_A = -40^\circ\text{C}$ to $+85^\circ\text{C}$)

Number	Symbol	ADMC201 Timing Requirements	Min	Max	Units
1	t_{perclk}	CLK Period	40	160	ns
2	t_{pwhclk}	CLK Pulse Width, High	20	-	ns
3	t_{pwlclk}	CLK Pulse Width, Low	20	-	ns
4	$t_{su}csb_wrb$	\overline{CS} Low before Falling Edge of \overline{WR}	0	-	ns
5	$t_{su}addr_wrb$	ADDR Valid before Falling Edge of \overline{WR}	0	-	ns
6	$t_{su}data_wrb$	DATA Valid before Rising Edge of \overline{WR}	13	-	ns
7	$t_{hd}wrb_data$	DATA Hold after Rising Edge of \overline{WR}	4.5	-	ns
8	$t_{hd}wrb_addr$	ADDR Hold after Rising Edge of \overline{WR}	4.5	-	ns
9	$t_{hd}wrb_csb$	\overline{CS} Hold after Rising Edge of \overline{WR}	4.5	-	ns
10	t_{pwlwrb}^1	\overline{WR} Pulse Width, Low	20	-	ns
11	t_{pwhwrb}^1	\overline{WR} Pulse Width, High	20	-	ns
12	$t_{hd}wrb_clk_h^1$	\overline{WR} Low after Rising Edge of CLK	7	-	ns
13	$t_{su}wrb_clk_h^1$	\overline{WR} High before Rising Edge of CLK	7	-	ns
14	$t_{su}wrb_clk_l^1$	\overline{WR} High before Falling Edge of CLK	10	-	ns
15	$t_{hd}clk_wrb_l^1$	\overline{WR} High after Falling Edge of CLK	10	-	ns
16	$t_{su}csb_rdb$	\overline{CS} Low before Falling Edge of \overline{RD}	0	-	ns
17	$t_{su}addr_rdb$	ADDR Valid before Falling Edge of \overline{RD}	0	-	ns
18	$t_{hd}rdb_addr$	ADDR Hold after Rising Edge of \overline{RD}	0	-	ns
19	$t_{hd}rdb_csb$	\overline{CS} Hold after Rising Edge of \overline{RD}	0	-	ns
20	t_{pwrdb}	\overline{RD} Pulse Width, Low	20	-	ns
21	t_{pwhrdb}	\overline{RD} Pulse Width, High	20	-	ns
22	$t_{su}rdb_clk_h$	\overline{RD} Low before Rising Edge of CLK	7.5	-	ns
23	$t_{hd}rdb_clk_h$	\overline{RD} Low after Rising Edge of CLK	7.5	-	ns
24	$t_{pwlresetb}$	\overline{RESET} Pulse Width, Low	$2 \times t_{perclk}$	-	ns

NOTE

¹All WRITES to the ADCM201 must occur within 1 System Clock Cycle (0 wait states).

Number	Symbol	ADMC201 Switching Characteristics	Min	Max	Units
25	$t_{dly}rdb_data$	DATA Valid after Falling Edge of \overline{RD}	-	23	ns
26	$t_{hd}rdb_data$	DATA Hold after Rising Edge of \overline{RD}	0	-	ns
27	t_{pwh_pio}	Digital I/O Pulse Width, High	$2 \times t_{perclk}$	-	ns
28	t_{pwl_pio}	Digital I/O Pulse Width, Low	$2 \times t_{perclk}$	-	ns

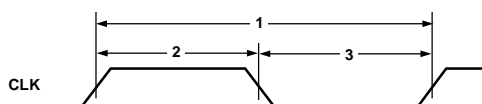

Figure 1. Clock Input Timing

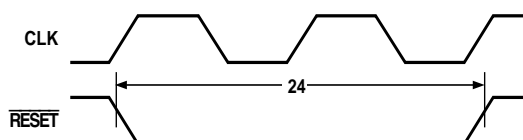
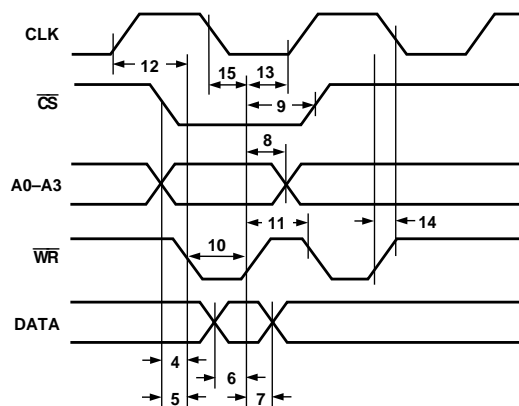

Figure 2. Reset Input Timing



NOTE:
ALL WRITES TO THE ADCM201 MUST OCCUR WITHIN ONE SYSTEM CLOCK CYCLE (i.e. 0 WAIT STATES)

Figure 3. Write Cycle Timing Diagram

ADMC201

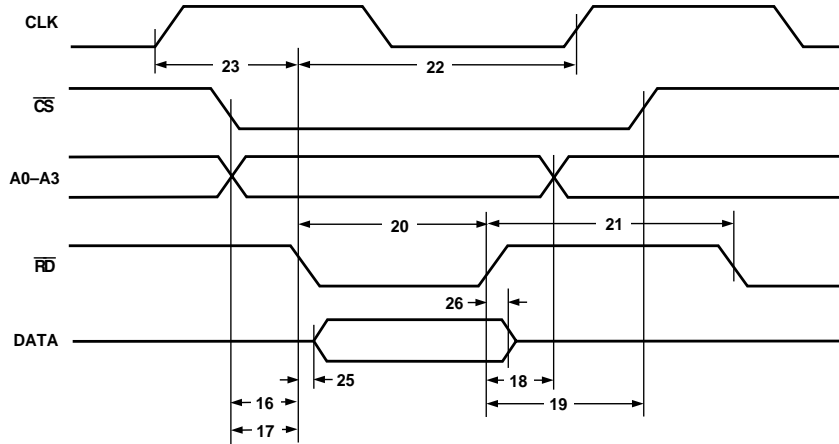

Figure 4. Read Cycle Timing Diagram

ABSOLUTE MAXIMUM RATINGS*

Supply Voltage (V_{DD})	-0.3 V to +7.0 V
Digital Input Voltage	-0.3 V to V_{DD}
Analog Input Voltage	-0.3 V to V_{DD}
Analog Reference Input Voltage	-0.3 V to V_{DD}
Digital Output Voltage Swing	-0.3 V to V_{DD}
Analog Reference Output Swing	-0.3 V to V_{DD}
Operating Temperature	-40°C to +85°C
Lead Temperature (Soldering, 10 sec)	+280°C

*Stresses greater than those listed above may cause permanent damage to the device. These are stress ratings only, and functional operation of the device at these or any other conditions greater than those indicated in the operational sections of this specification is not implied. Exposure to absolute maximum rating conditions for extended periods may affect device reliability.

ORDERING GUIDE

Part Number	Temperature Range	Package Description	Package Option
ADMC201AP	-40°C to +85°C	68-Pin PLCC	P-68A

CAUTION

ESD (electrostatic discharge) sensitive device. Electrostatic charges as high as 4000 V readily accumulate on the human body and test equipment and can discharge without detection. Although the ADMC201 features proprietary ESD protection circuitry, permanent damage may occur on devices subjected to high energy electrostatic discharges. Therefore, proper ESD precautions are recommended to avoid performance degradation or loss of functionality.



PIN DESIGNATIONS

Pin	Mnemonic	Type	Description	Pin	Mnemonic	Type	Description
1	D9	BIDIR	Data Bit 9	38	REFOUT	O/P	Internal 2.5 V Analog Reference
2	D10	BIDIR	Data Bit 10	39	V _{DD}	SUP	+5 V Digital Power Supply
3	D11	BIDIR	Data Bit 11, MSB	40	DGND	GND	Digital Ground
4	PIO0	BIDIR	Programmable Digital I/O Bit 0	41	DGND	GND	Digital Ground
5	PIO1	BIDIR	Programmable Digital I/O Bit 1	42	DGND	GND	Digital Ground
6	PIO2	BIDIR	Programmable Digital I/O Bit 2	43	DGND	GND	Digital Ground
7	PIO3	BIDIR	Programmable Digital I/O Bit 3	44	V _{DD}	SUP	+5 V Digital Power Supply
8	PIO4	BIDIR	Programmable Digital I/O Bit 4	45	NC		No Connect
9	PIO5	BIDIR	Programmable Digital I/O Bit 5	46	DGND	GND	Digital Ground
10	V _{DD}	SUP	+5 V Digital Power Supply	47	STOP	I/P	PWM Timer Output Disable
11	A3	I/P	Address Bit 3, MSB	48	PWMSYNC	O/P	PWM Synchronization Output
12	A2	I/P	Address Bit 2	49	CP	O/P	PWM Timer Output C Prime
13	A1	I/P	Address Bit 1	50	C	O/P	PWM Timer Output C
14	A0	I/P	Address Bit 0, LSB	51	BP	O/P	PWM Timer Output B Prime
15	NC		No Connect	52	NC		No Connect
16	RESET	I/P	Chip Reset	53	B	O/P	PWM Timer Output B
17	CONVST	I/P	A/D Conversion Start	54	AP	O/P	PWM Timer Output A Prime
18	IRQ	O/P	Interrupt Request (Pull-Up Required)	55	A	O/P	PWM Timer Output A
19	V _{DD}	SUP	+5 V Digital Power Supply	56	DGND	GND	Digital Ground
20	DGND	GND	Digital Ground	57	DGND	GND	Digital Ground
21	CLK	I/P	External Clock Input	58	DGND	GND	Digital Ground
22	WR	I/P	Write Select	59	V _{DD}	SUP	+5 V Digital Power Supply
23	RD	I/P	Output Enable/Read	60	D0	BIDIR	Data Bit 0, LSB
24	CS	I/P	Chip Select	61	D1	BIDIR	Data Bit 1
25	NC		No Connect	62	D2	BIDIR	Data Bit 2
26	V _{DD}	SUP	+5 V Analog Power Supply	63	D3	BIDIR	Data Bit 3
27	AGND	GND	Analog Ground	64	D4	BIDIR	Data Bit 4
28	AGND	GND	Analog Ground	65	D5	BIDIR	Data Bit 5
29	U	I/P	Analog Input U	66	D6	BIDIR	Data Bit 6
30	V	I/P	Analog Input V	67	D7	BIDIR	Data Bit 7
31	W	I/P	Analog Input W	68	D8	BIDIR	Data Bit 8
32	SGND	GND	Analog Signal Ground				
33	REFIN	I/P	Analog Reference Input				
34	AUX3	I/P	Auxiliary Analog Input 3				
35	AUX2	I/P	Auxiliary Analog Input 2				
36	AUX1	I/P	Auxiliary Analog Input 1				
37	AUX0	I/P	Auxiliary Analog Input 0				

Pin Types	Pin Types
I/P = Input Pin	BIDIR = Bidirectional Pin
O/P = Output Pin	SUP = Supply Pin
GND = Ground Pin	

PIN CONFIGURATION

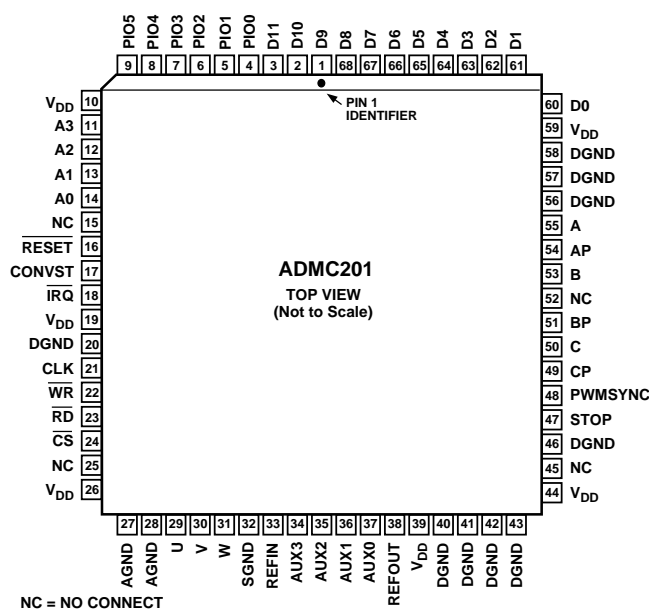

ADMC201

ANALOG INPUT BLOCK

The ADC201 contains an 11-bit resolution, successive approximation analog-to-digital (A/D) converter with two's complement output data format. The analog input range is ± 2.5 V (0 V–5 V) with a 2.5 V offset as defined by REFIN. The on-chip 2.5 V \pm 5% reference is utilized by connecting the REFOUT pin to the REFIN pin.

The input stage to the A/D converter is a four channel SHA which allows the four channels (U, V, W and AUX) to be held simultaneously and then sequentially digitized. The auxiliary input (AUX) is fed by a four channel multiplexer that allows the channels AUX0, AUX1, AUX2 and AUX3 to be individually converted along with the primary channels U, V and W. The auxiliary inputs are ideal for reading slower changing variables such as bus voltage and temperature. The A/D conversion time is determined by the system clock frequency, which can range from 6.25 MHz to 12.5 MHz. The Sample and Hold (SHA) acquisition time is 20 system clock cycles and is independent of the number of channels sampled and/or digitized. Forty system clock cycles are required to complete each A/D conversion. The analog channel sampling is flexible and is programmable through the SYSCTRL register. The minimum number of channels per conversion is two. The throughput time of the analog acquisition block can be calculated as follows:

$$t_{AA} = t_{SHA} + (n \times t_{CONV})$$

where

t_{AA} = analog acquisition time,

n = # channels,

t_{SHA} = SHA acquisition time (20 \times system clock period),

t_{CONV} = conversion time (40 \times system clock period) per channel.

A/D Conversions are initiated via the CONVST pin. A synchronizing pulse (PWMSYNC) is provided at the beginning of each PWM cycle. This pulse can be used to synchronize the A/D conversion process to the PWM switching frequency.

Operating the A/D Converter

The A/D converter can be set up to convert a sequence of channels as defined in the SYSCTRL register (see Table VI). The default channel select mode after RESET is to convert channels V and W only. This is two-/three-phase mode. Three-/three-phase mode converts channels U, V, W, and/or AUX. Three-/three-phase mode is selected by writing a 1 to Bit 3 of the SYSCTRL register. After the conversion process is complete, the channels can be read in any order.

There are two methods that can be used to indicate when the A/D conversions are completed and the data is ready: interrupt driven and software timing.

Interrupt Driven Method

Interrupts can be used to indicate the end of conversion for a group of channels. Before beginning any A/D conversions, Bit 7 of the SYSCTRL register must be set to 1 to enable A/D conversion interrupts. Then, when an A/D conversion is complete, an interrupt will be generated. After an interrupt is detected, Bit 0 of the SYSSTAT register must be checked to determine if the A/D converter was the source. Reading the SYSSTAT register automatically clears the interrupt flag bits.

Software Timing Method

An alternative method is to use the DSP or microcontroller to keep track of the amount of time elapsed between CONVST and the expected completion time ($n \times t_{CONV}$).

Reading Results

The 11-bit A/D conversion results for channels U, V, W and AUX are stored in the ADCU, ADCV, ADCW and ADCAUX registers respectively. The two's complement data is left justified and the LSB is set to zero. The relationship between input voltage and output coding is shown in Figure 5.

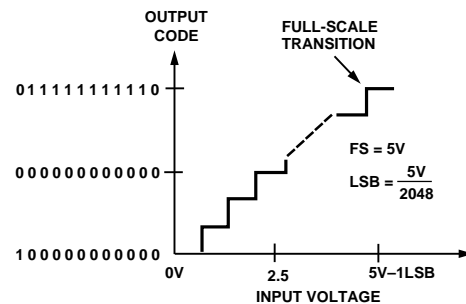

Figure 5. Transfer Function

Sample and Hold

After powering up the ADC201, bring the $\overline{\text{RESET}}$ pin low for a minimum of two clock cycles in order to enable A/D conversions. Before initiating the first conversion (CONVST) after a reset, the SHA time of 20 system clock cycles must occur. A conversion is initiated by bringing CONVST high for a minimum of one system clock cycle. The SHA goes into hold mode at the falling edge of clock.

Following completion of the A/D conversion process, a minimum of 20 system clock cycles are required before initiating another conversion in order to allow the sample and hold circuitry to reacquire the input signals.

If a CONVST is initiated before the 20 clock cycles have elapsed, the embedded control sequencer will delay conversion until this requirement is met.

PWM TIMER BLOCK OVERVIEW

The PWM timers have 12-bit resolution and support programmable pulse deletion and deadtime. The ADCM201 generates three center-based signals A, B and C based upon user-supplied duty cycles values. The three signals are then complemented and adjusted for programmable deadtime to produce the six outputs. The ADCM201 PWM master switching frequency can range from 2.5 kHz to 20 kHz, when using a 10 MHz system clock. The master frequency selection is set as a fraction of the PWMTM register. If the system clock is 10 MHz, then the minimum edge resolution available is 100 ns.

The output format of the PWM block is active LO. There is an external input to the PWM timers (STOP) that will disable all six outputs within one system clock when the input is HIGH.

The ADCM201 has a PWM Synchronization output (PWMSYNC) which brings out the master switching frequency from the PWM timers. The width of the PWMSYNC pulse is equal to one system clock cycle. For example, if the system clock is 10 MHz, the PWMSYNC width would be equal to 100 ns.

PWM Master Switching Period Selection

The switching time is set by the PWMTM register which should be loaded with a value equal to the system clock frequency divided by the desired master switching frequency. For example, if the desired switching frequency is 8 kHz and the system clock frequency is 10 MHz, then the PWMTM register should be loaded with 1250 ($10 \text{ MHz}/8 \text{ kHz}$). The PWMCHA, PWMCHB and PWMCHC registers are loaded with the desired on-time and their values would be calculated as a ratio of the PWMTM register value. Note: $\text{Desired Pulse Density} = (\text{PWMCHx register}) / (\text{PWMTM register})$.

The beginning of each PWM cycle is marked by the PWMSYNC signal. New values of PWMCHA, PWMCHB and PWMCHC must all be loaded into their respective registers at least four system clock cycles before the beginning of a new PWM cycle. All three registers must be updated for any of them to take effect. New PWM on/off times are calculated during these four clock cycles and therefore the PWMCHA, PWMCHB and PWMCHC registers must be loaded before this time. If this timing requirement is not met, then the PWM outputs may be invalid during the next PWM cycle.

PWM Example

The following example uses a system clock speed of 10 MHz. The desired PWM master switching frequency is 8 kHz and the desired on-time for the timers A, B and C are 25%, 50% and 10% respectively. The values for the PWMCHA, PWMCHB and PWMCHC registers must be calculated as ratios of the PWMTM register (1250 in this example). To achieve these duty cycles, load the PWMCHA register with 313 (1250×0.25), PWMCHB with 625 (1250×0.5) and PWMCHC with 125 (1250×0.1).

Programmable Deadtime

With perfectly complemented PWM drive signals and nonideal switching characteristics of the power devices, both transistors in a particular leg might be switched on at the same time, resulting in either a power supply trip, inverter trip or device destruction. In order to prevent this, a delay must be introduced between the complemented signal edges. For example, the rising edge of AP occurs before the falling edge of A, and the falling edge of the complemented A occurs after the rising edge of A. This capability is known as programmable deadtime.

The ADCM201 programmable deadtime value is loaded into the 7-bit PWMDT register, in which the LSB is set to zero internally, which means the deadtime value is always divisible by two. With a 10 MHz system clock, the 0–126 range of values in PWMDT yield a range of deadtime values from 0 μs to 12.6 μs in 200 ns steps. Figure 6 shows PWM timer A with a programmable deadtime of PWMDT.

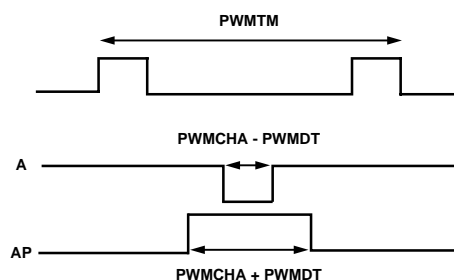

Figure 6. Programmable Deadtime Example

Pulse Deletion

The pulse deletion feature prevents a pulse from being generated when the user-specified duty cycle results in a pulse duration shorter than the user-specified deletion value. The pulse deletion value is loaded into the 7-bit register PWMPD. When the user-specified on-time for a channel would result in a calculated pulse width less than the value specified in the PWMPD register, then the PWM outputs for that channel would be set to full off (0%) and its prime to full on (100%). This is valid for A, AP, B, BP, C and CP. This feature would be used in an environment where the inverter's power transistors have a minimum switching time. If the user-specified duty cycle would result in a pulse duration shorter than the minimum switching time of the transistors, then pulse deletion should be used to prevent this occurrence. With a 10 MHz system clock, the 0–127 range of values in PWMPD yield a range of deadtime values from 0 μs to 12.7 μs in 100 ns steps.

External PWM Shutdown

There is an external input pin (STOP) to the PWM timers that will disable all six outputs when it goes HIGH. When the STOP pin goes HIGH, the PWM timer outputs will all go HIGH within one system clock cycle. When the STOP pin goes LOW, the PWM timer outputs are re-enabled within one system clock cycle. If external PWM shutdown isn't required, tie the STOP pin LOW.

ADMC201

VECTOR TRANSFORMATION BLOCK OVERVIEW

The Vector Transformation Block performs both Park and Clarke coordinate transformations to control a three-phase motor (Permanent Magnet Synchronous Motor or Induction Motor) via independent control of the decoupled rotor torque and flux currents. The Park & Clarke transformations combine to convert three-phase stator current signals into two orthogonal rotor referenced current signals I_d and I_q . I_d represents the flux or magnetic field current and I_q represents the torque generating current. The I_d and I_q current signals are used by the processor's motor torque control algorithm to calculate the required direct V_d and quadrature V_q voltage components for the motor. The forward Park and Clarke transformations are used to convert the V_d and V_q voltage signals in the rotor reference frame to three-phase voltage signals (U, V, W) in the stator reference frame. These are then scaled by the processor and written to the ADCM201's PWM registers in order to drive the inverter. The figures below illustrate the Clarke and Park Transformations respectively.

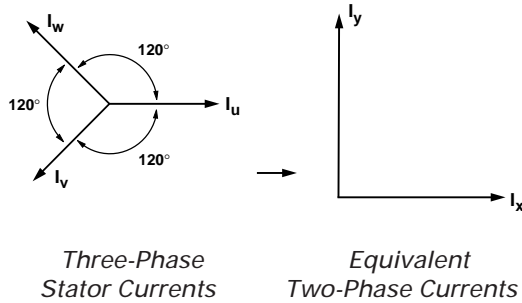

Figure 7. Reverse Clarke Transformation

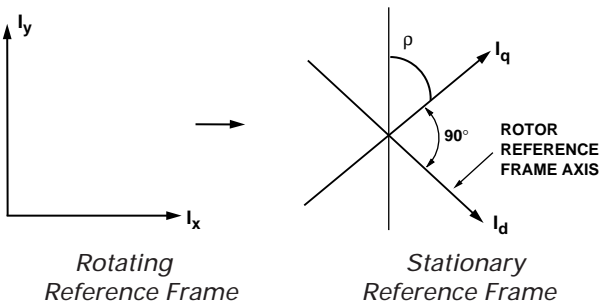

Figure 8. Reverse Park Transformation

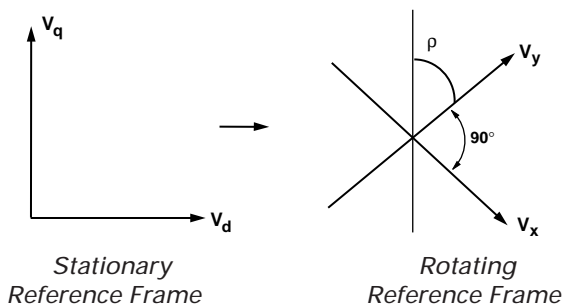

Figure 9. Forward Park Transformation

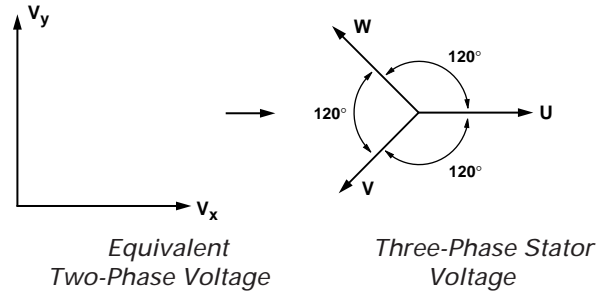

Figure 10. Forward Clarke Transformation

Operating/Using the Vector Transformation Block

After powering up the ADCM201, $\overline{\text{RESET}}$ must be driven low for a minimum of two clock cycles to enable vector transformations.

The vector transformation block can perform either a forward or reverse transformation.

Reverse Transformation is defined by the following operations: (a) Clarke: 3-phase current signals to 2-phase current signals followed by (b) Park: 2-phase current signals cross multiplied by $\sin \rho$, $\cos \rho$ which effectively measures the current components with respect to the rotor (stationary) where ρ is the electrical angle of the rotor field with respect to the stator windings.

Forward transformation is defined by the following operations: (a) Park: 2-phase voltage signals cross multiplied by $\sin \rho$, $\cos \rho$ followed by (b) Clarke: 2-phase to 3-phase voltage signal conversion.

In order to provide maximum flexibility in the target system, the ADCM201 operates in an asynchronous manner. This means that the functional blocks (analog input, reverse transformation, forward transformation and PWM timers) operate independently of each other. The reverse and forward vector transformation operations cannot occur simultaneously. All vector transformation registers, except for RHO/RHOP, are twos complement. RHO/RHOP are unsigned ratios of 360°. For example, 45° would be $45/360 \times 2^{12}$.

Performing a Reverse Transformation

A reverse transformation is initiated by writing to the reverse rotation angle register RHO and operates on the values in the PHIP1, PHIP2 and PHIP3 registers. When the reverse transformation is in 2/3 mode, PHIP1 is calculated from PHIP2 and PHIP3. This is used in systems where only two-phase currents are measured. The reverse transformation 2/3 mode is set by clearing Bit 10 in the SYSCTRL register and is the default mode after RESET.

In order to perform a reverse transformation, first write to the PHIP2 and PHIP3 registers, and to the PHIP1 register if not in 2/3 mode. Then initiate the transformation by writing the reverse rotation angle to the RHO register.

The reverse rotation will be completed in 37 system clock cycles after the rotation is initiated. If Bit 6 of the system control register is set, then an interrupt will be generated on completion. When an interrupt occurs, the user must check Bit 1 of the SYSSTAT register to determine if the vector transformation block was the source of the interrupt.

During the vector transformation, the vector transformation registers must not be written to or the vector rotation results will be invalid.

Reverse Clarke Transformation

The first operation is the Clarke transformation in which the three-phase motor current signals (I_u , I_v , I_w) are converted to sine and cosine orthogonal signals (I_x and I_y). These signals represent the equivalent currents in a two-phase ac machine and is the signal format required for the Park rotation. The three-phase input signals are of the form:

$$\begin{aligned} \text{PHIP1} \quad I_u &= I_s \cos \theta \\ \text{PHIP2} \quad I_v &= I_s \cos (\theta + 120) \\ \text{PHIP3} \quad I_w &= I_s \cos (\theta + 240) \end{aligned}$$

and the Park rotation requires inputs in the form $I_s \cos \theta$ and $I_s \sin \theta$, therefore we need to generate $I_s \sin \theta$.

This is calculated from:

$$\text{IY} \quad I_s \sin \theta = \frac{1}{\sqrt{3}} (I_s \cos (\theta + 240) - I_s \cos (\theta + 120))$$

After the reverse transform, registers I_x and I_y contain the 2-phase input current information.

In the case where 2- of 3-phase information (PHIP2/3 only) is provided, then PHIP1 will be derived from the simple fact that all sum to zero. This value is then placed in the IX register.

$$\text{IX} = I_x = I_s \cos \theta = -I_s \cos (\theta + 120) - I_s \cos (\theta + 240)$$

Reverse Park Rotation

IX/IY are then processed together with the digital angle ρ (RHO) by a Park rotation. If the input signals are I_x and I_y , then the rotation can be described by:

$$\begin{aligned} \text{ID} \quad I_d &= I_x \times \cos \rho + I_y \times \sin \rho \\ \text{IQ} \quad I_q &= -I_y \times \sin \rho + I_x \times \cos \rho \end{aligned}$$

where ID and IQ are the outputs of the Park rotation.

$\cos \rho$ and $\sin \rho$ are required for the Park rotation, and are calculated internally.

Substituting for I_x and I_y in the above yields:

$$\begin{aligned} \text{ID} \quad I_d &= I_s \cos \theta \times \cos \rho + I_s \sin \theta \times \sin \rho = I_s \cos (\theta - \rho) \\ \text{IQ} \quad I_q &= I_s \sin \theta \times \cos \rho - I_s \cos \theta \times \sin \rho = I_s \sin (\theta - \rho) \end{aligned}$$

Performing a Forward Transformation

In order to perform a forward rotation, write values to the VD and VQ registers and then initiate the transformation by writing the rotation angle to the register RHOP. The forward transformation will only operate correctly when Bit 10 in the SYCTRL register is set (i.e., in 3/3 mode).

The forward rotation will be completed in 40 system clock cycles after the rotation is initiated. If Bit 6 of the system control register is set, then an interrupt will be generated on completion. When an interrupt occurs, the user must check Bit 1 of the system status register, SYSSTAT, to determine if the vector transformation block was the source of the interrupt.

During the vector transformation, the transformation registers must not be written to or the vector rotation results will be invalid.

Forward Park Rotation

If the input signals are represented by V_d and V_q , then the transformation can be described by:

$$\begin{aligned} \text{VX} \quad V_x &= V_d \times \cos \rho - V_q \times \sin \rho \\ \text{VY} \quad V_y &= V_d \times \sin \rho + V_q \times \cos \rho \end{aligned}$$

where V_x and V_y are the outputs of the Park Rotation, and are the inputs to the reverse Clarke transformation.

Forward Clarke Transformation (2- to 3-Phase)

The second operation to be applied to the above results, is the Forward Clarke Transformation where 2-phase (stator) voltage signals are converted to 3-phase (stator) voltage signals.

For the inverse Clarke transform we require three-phase outputs of the form below:

$$\begin{aligned} \text{PHV1} \quad V &\cos \alpha \\ \text{PHV2} \quad V &\cos (\alpha + 120) \\ \text{PHV3} \quad V &\cos (\alpha + 240) \end{aligned}$$

We have two quadrature voltages ($V \cos \alpha$ and $V \sin \alpha$) available.

$$\text{PHV2} \quad V \cos (\alpha + 120) = -\frac{1}{2} \times V \cos \alpha - \frac{\sqrt{3}}{2} \times V \sin \alpha$$

$$\text{PHV3} \quad V \cos (\alpha + 240) = -\frac{1}{2} \times V \cos \alpha + \frac{\sqrt{3}}{2} \times V \sin \alpha$$

PROGRAMMABLE DIGITAL INPUT/OUTPUT PORT

The ADCM201 has a six bit programmable digital I/O port. Each bit is individually configurable as input or output. All bits configured as inputs have the ability to operate as interrupt sources. Each pin is independently capable of generating an interrupt should its input level change.

Configuring the Programmable Digital I/O Port

The PIOCTRL register is used to configure the individual bits on the programmable digital I/O port as either inputs or outputs and to enable change of state interrupts. The lower six bits of PIOCTRL control the direction (either input or output) of the individual bits. A zero configures the corresponding bit as an input; conversely a 1 configures the corresponding bit as an output. The upper six bits of PIOCTRL are used to enable the individual bits for use as change of state interrupt sources. A 0 disables change of state interrupt generation and a 1 enables change of state interrupt generation. The interrupt enable for a bit configured as an output is ignored. At power-up or $\overline{\text{RESET}}$, all six bits of the digital port are configured as input and change of state interrupt generation is disabled.

Using the Programmable Digital I/O Port

The PIODATA register is used to write to and read from the digital I/O port. Bits 0-5 of the PIODATA register correspond to PIO 0-5 on the ADCM201. Bits 6-11 of PIODATA are unused and always contain 0. Read from PIODATA to determine the state of PIO 0-5. Write to PIODATA to change the states of PIO 0-5. Writing to bits configured as input has no effect. Reading from bits configured as output will return the last value written.

ADMC201

INTERRUPT GENERATION

There are three interrupt sources on the ADCM201 that may be independently enabled to generate interrupts. The first interrupt source is the Analog Input Block, which, if enabled, generates an interrupt at the end of conversion. The second interrupt source is the Vector Transformation Block, which, if enabled, generates an interrupt at the end of a Vector Transformation. The third interrupt source is the Digital I/O Block. Each digital I/O bit, if configured for input and enabled, generates an interrupt when its input level changes.

When a 1 is stored in Bit 7 of the SYSCTRL register, ADC interrupts are enabled. When a 1 is stored in Bit 6 of the SYSCTRL register, Vector Transformation interrupts are enabled. When a 1 is stored in any of Bits 6–11 of the PIOCTRL register, digital I/O change of state interrupts are enabled for Bits 0–5 respectively. Upon a reset of the chip, all bits are set to the default condition, 0, thus disabling all interrupts.

When an enabled interrupt occurs, Bit 11 of the SYSSTAT register becomes a 1. If that interrupt had been an ADC interrupt, Bit 0 of SYSSTAT register would also be set to 1. If that interrupt had been a Vector Transformation interrupt, Bit 1 of SYSSTAT would be set to 1. If that interrupt had been a digital I/O interrupt, then Bit 2 of the SYSSTAT would be set to 1. Whenever the SYSSTAT register is read, these four bits go back to their default state, 0, immediately after their values are loaded onto the data bus. Upon a reset, these four bits also go to their default state, 0.

The $\overline{\text{IRQ}}$ pin has an open-drain driver, which will drive it low at the appropriate times, but the user must supply an external pull-up resistor to bring the node back high when it is not being pulled low.

The $\overline{\text{IRQ}}$ pin operates in one of two modes, edge mode or level mode. In edge mode, when an enabled interrupt occurs, the $\overline{\text{IRQ}}$ pin will be driven low for one system clock period. In level mode, when an enable interrupt occurs, the $\overline{\text{IRQ}}$ pin will be driven low, and will remain low until the SYSSTAT register is read. The combination of level mode and the open-drain driver allows multiple interrupt sources in an application to drive a single interrupt input line on the host DSP or microprocessor. Edge mode or level mode is determined with Bit 8 of the SYSCTRL register. Edge mode (0) is the default; a 1 in this bit will put the $\overline{\text{IRQ}}$ pin into level mode.

The recommended method of using the interrupt generation capability is to set edge or level mode, enable the appropriate interrupts, and then monitor the $\overline{\text{IRQ}}$ line. After the $\overline{\text{IRQ}}$ pin goes low, the SYSSTAT register of the ADCM201 should be read, (1) to determine if it was this chip that caused the interrupt, if other lines are wired together with this $\overline{\text{IRQ}}$ pin, and (2) if it was this chip, to determine if it was generated by the Analog Input, Digital I/O and/or the Vector Transformation Blocks. Once this is done, the appropriate interrupt handling routine may be executed.

APPLICATION NOTE LIST

1. AN-407 *AC Motor Control Experiments Using the ADCM200 Evaluation Board*
2. AN-408 *AC Motor Control Using the ADCM200 Motion Coprocessor*
3. AN-409 *Advanced Motor Control Techniques Using the ADCM200 Motion Coprocessor*

POWER SUPPLY CONNECTIONS AND SETUP

The nominal positive power supply level (V_{DD}) is $+5\text{ V} \pm 5\%$. The Positive Power supply V_{DD} should be connected to all ADCM201 V_{DD} pins (10, 19, 26, 39, 44, 59). The SGND pin (32) and both AGND pins (27, 28) should be star point connected at a point close to the AGND pins of the ADCM201. The DGND pins (20, 40, 41, 42, 43, 46, 56, 57, 58) should also be connected to AGND pins close to the ADCM201.

Power supplies should be decoupled at the power pins using a $0.1\ \mu\text{F}$ capacitor. A $220\ \text{nF}$ capacitor must also be connected as close as possible between REFIN (Pin 33) and SGND (Pin 32). In addition, the $\overline{\text{IRQ}}$ requires a 15K pull-up to the V_{DD} supply.

SYSTEM CLOCK FREQUENCY

The nominal range of the input clock for the ADCM201 is 6.25 MHz to 25 MHz. The external CLK frequency can be internally divided down by 2 by writing to Bit 5 of the SYSCTRL register. If the external CLK is faster than 12.5 MHz then it is necessary to internally divide it down.

DSP/CONTROLLER INTERFACE

The ADCM201 has a 12-bit bidirectional parallel port for interfacing with Analog Devices' ADSP-2100 DSP family or microcontrollers/microprocessors.

The ADCM201 coprocessor is designed to be conveniently interfaced to the ADI's family of Fixed-Point DSPs. Figures 11 and 12 show the interfacing between the ADCM201 and the ADSP-2101/2105/2115, ADSP-2171, ADSP-2181, TMS320C2X DSPs. In the case of the TMS320C2X, some glue logic is required to decode the $\overline{\text{RD}}/\overline{\text{WR}}$ lines and invert the CLKOUT1 signal.

The ADSP-2101/2105/2115 CLKOUT frequency equals the crystal/clock frequency of its CLKIN. This signal (CLKOUT) can be used to directly drive the CLK line (Pin 21) on the ADCM201. The ADCM201 coprocessor can be operated with a clock frequency between the of 6.25 MHz and 25 MHz. If the clock frequencies is greater than 12.5 MHz, then it is necessary to internally divide down the external clock to derive the ADCM201's system clock (via SYSCTRL register).

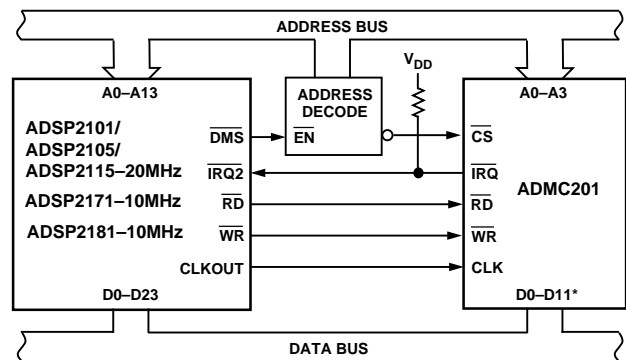

*NOTE:
BY MAPPING THE ADCM201 DATA BUS TO THE TWELVE HIGHEST BITS OF THE ADSP DATA BUS, FULL-SCALE OUTPUTS FROM THE ADC CAN BE REPRESENTED BY ± 1.0 IN FIXED POINT ARITHMETIC.

Figure 11. ADI Digital Signal Processor/Microcomputer

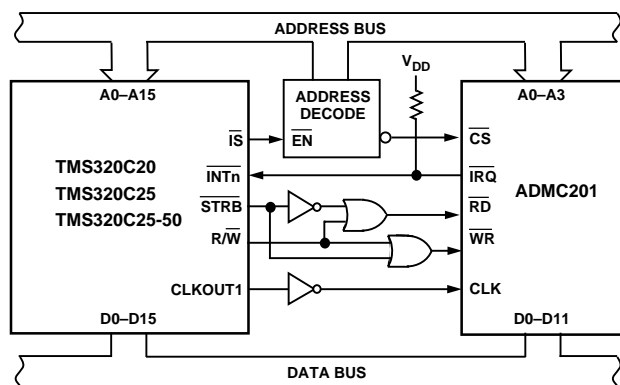

Figure 12. T1 Second Generation Devices TMS320C20/ C25/C25-50

In the case of the ADSP-2171/2181, the system clock is internally scaled, a 10 MHz system clock will derive a 20 MHz CLKOUT. In the case of the TMS320C2X, the CLKOUT1 signal is derived from the system clock divided by a factor of 4, consequently a 50 MHz TMS320C25-50 will derive a 12.5 MHz CLKOUT1 for use by the ADCM201.

Note: a pull-up resistor is required on the IRQ (Pin 18) output from the ADCM201. The STOP (Pin 47) must be tied low if not in use.

REGISTER ADDRESSING

Four address lines (A0 through A3) are used in conjunction with the control lines (\overline{CS} , \overline{WR} , \overline{RD}) to select registers 0 through 15. The \overline{CS} and \overline{RD} control lines are active low. The registers are given symbolic names.

Table II.

Pin	Function
\overline{CS}	Enables the ADCM201 register interface (connect via chip select logic-active low)
\overline{RD}	Places data from the internal register onto the data bus
\overline{WR}	Loads the internal register with data on the data bus on its positive edge

DESCRIPTION OF THE REGISTERS

All unspecified register locations are reserved.

SYSCTRL	System Control Register (See Tables V, VI, VII).
SYSSTAT	System Status Register (See Table VII).
ADCU	These registers contain the results from the first three analog input channels U, V, and W. The output data format is twos complement and, therefore, Bit 0 is always zero as the A/D converter has 11-bit resolution.
ADCV	
ADCW	
ADCAUX	This register contains the conversion result of the auxiliary channels AUX0, AUX1, AUX2 or AUX3.
PWMTM	PWM Master Switching Period
PWMCHA	PWM Channel A On-Time
PWMCHB	PWM Channel B On-Time
PWMCHC	PWM Channel C On-Time
PWMDT	PWM Programmable Deadtime Value
PWMPD	PWM Programmable Pulse Deletion Value
ID/IQ	These are the results of the reverse rotation (torque and flux components).
PHV1/2/3	These are the results from the forward Clarke Transformation.

PHIP1/2/3	The inputs for reverse vector transformation (Clarke and Park).
IX/IY	These registers contain the results of the Clarke transformation that are the inputs to the reverse Park rotation.
VX, VY	VX, VY contain the results of the forward Park rotation.
RHOP	RHOP is the angle used during the forward vector transformation. Writing to the RHOP register causes the forward rotation to start based on values in RHOP, VD and VQ registers.
RHO	RHO is the angle used during the reverse vector transformation. Writing to this register starts the reverse rotation using the values in the RHO, PHIP1/2/3 registers.
	RHO and RHOP are unsigned ratios of 360°. For example, 45 degrees would be $45/360 \times 2^{12}$.
PIODATA	Write to this register to change the digital outputs and read from it to determine the state of digital inputs.
PIOCTRL	This register is used to configure the digital I/O as input or output and to enable interrupt on change of state.

Table III. Write Registers

Name	A ₃	A ₂	A ₁	A ₀	Register Function
RHO	0	0	0	0	Load RHO (ρ) and Start Reverse Transform
PHIP1/VD	0	0	0	1	Reverse Rotation Direct Input/Forward Direct Input
PHIP2/VQ	0	0	1	0	Reverse Rotation Direct Input/Forward Direct Input
PHIP3	0	0	1	1	Reverse Rotation Direct Input
RHOP	0	1	0	0	Load RHOP (ρ) and Start Forward Transform
PWMTM	0	1	0	1	PWM Master Switching Period
PWMCHA	0	1	1	0	PWM Channel A On-Time
PWMCHB	0	1	1	1	PWM Channel B On-Time
PWMCHC	1	0	0	0	PWM Channel C On-Time
PWMDT	1	0	0	1	PWM Programmable Deadtime (7-Bit Register)
PWMPD	1	0	1	0	PWM Pulse Deletion Value (7-Bit Register)
PIOCTRL	1	0	1	1	Digital I/O Control
PIODATA	1	1	0	0	Digital I/O Data Write (6-Bit Register)
SYSCTRL	1	1	0	1	System Control
	1	1	1	0	Reserved
	1	1	1	1	Reserved

Table IV. Read Registers

Name	A ₃	A ₂	A ₁	A ₀	Register Function
ID/PHV1/VX	0	0	0	0	Reverse Rotation Result (I_{DS})/Forward Result $\cos +0^\circ$
IQ/PHV2	0	0	0	1	Reverse Rotation Result (I_{QS})/Forward $\cos +120^\circ$
IX/PHV3	0	0	1	0	Reverse Clarke $\cos +0^\circ$ /Forward Result $\cos +240^\circ$
IY/VY	0	0	1	1	Reverse Clarke $\cos +90^\circ$ /Forward $\cos +90^\circ$
	0	1	0	0	Reserved
ADCV	0	1	0	1	A/D Conversion Result Channel V
ADCW	0	1	1	0	A/D Conversion Result Channel W
ADCAUX	0	1	1	1	A/D Conversion Result Auxiliary Channel
ADCU	1	0	0	0	A/D Conversion Result Channel U
	1	0	0	1	Reserved
	1	0	1	0	Reserved
	1	0	1	1	Reserved
PIODATA	1	1	0	0	Digital I/O Data Read (6-Bit Register)
SYSCTRL	1	1	0	1	System Control
SYSSTAT	1	1	1	0	System Status
	1	1	1	1	Reserved

Table V. System Control (SYSCTRL) Registers

Bit	Function	RESET Default
0	Auxiliary Channel Selection	0
1	Auxiliary Channel Selection	0
3	Enables U Channel Conversion (1 = Enable) Two-/Three-Phase Mode	0
4	Enables AUX Channel Conversion (0 = Disable, 1 = Enable)	0
5	Divide External Clock by 2 (0 = No, 1 = Yes)	0
6	Park Interrupt Enable	0
7	ADC Interrupt Enable (0 = Disable, 1 = Enable)	0
8	$\overline{\text{IRQ}}$ Pin Format (Edge or Level Based Interrupt Requests) (0 = Edge)	0
10	Reverse Rotation (0 = 2/3, 1 = 3/3) Forward Rotation (1 = Enable)	0

Table VI. SYSCTRL Auxiliary Channel Selection

Bit 0	Bit 1	Auxiliary Channels Converted
0	0	AUX0
0	1	AUX1
1	0	AUX2
1	1	AUX3

Table VII. SYSCTRL Analog Input Channel Selection

Bit 3	Bit 4	Channels Converted	Mode
0	0	V, W (Default)	Two-/Three-Phase
0	1	V, W, AUX	Two-/Three-Phase
1	0	U, V, W	Three-/Three-Phase
1	1	U, V, W, AUX	Three-/Three-Phase

- Bit 0, 1 Auxiliary Channel Selection.
- Bit 3 Channel U Conversion Enable. If Bit 3 is set to 1, then Channel U will be converted along with V, W and/or AUX. This bit selects three-/three-phase mode.
- Bit 4 Aux Channel Conversion Enable. If Bit 4 is set to 1, then the AUX input will be converted along with the channels V, W and/or U.
- Bit 5 If Bit 5 = 1, then the external clock will be divided by two to derive the system clock. If the external clock frequency is greater than 12.5 MHz, then this bit must be set.
- Bit 6 Park Interrupt Enable. This bit allows interrupts to be generated when the Park rotation is completed.
- Bit 7 ADC Interrupt Enable. This bit allows interrupts to be generated when the analog-to-digital conversion process is complete.
- Bit 8 $\overline{\text{IRQ}}$ Pin Format—Edge or Level Interrupt Selection. If Bit 8 is set to 0, then an interrupt will cause a pulse of one system clock to be generated on the $\overline{\text{IRQ}}$ pin. If Bit 8 is set to 1, then an interrupt causes the $\overline{\text{IRQ}}$ output to go LOW (logic 0). The $\overline{\text{IRQ}}$ output pin will remain LOW until the SYSSTAT register is read.
- Bit 10 If Bit 10 is set to 1, then the reverse Park transformation will be formed in 3/3 mode. For Forward transformations, this bit must be set to 1.

ADMC201

Table VIII. System Status Register (SYSSTAT)¹

Bit	Function	RESET Default
0	A/D Conversion Completion Interrupt (1 = True)	0
1	Vector Transformation Completion Interrupt (1 = True)	0
2	Digital I/O Change of State Interrupt (1 = True)	0
4	Rotation Results are Valid (1 = Valid)	X ²
11	IRQ Generated from This Device (1 = True)	0

NOTES

¹Reading this register clears the interrupt status flags Bits 0, 1, 2 and 11.

²Undefined until the first Vector Transformation has started

- Bit 0 A/D Conversion Completion Interrupt. This register is set to 1 when the A/D conversion process has completed and ADC interrupts have been enabled in the SYSCTRL register.
- Bit 1 Interrupt Status. This register is set to 1 when the Vector Transformation is completed and the Vector Transformation completion interrupts have been enabled.
- Bit 4 This bit is set to 1 when the rotation results are valid reading this.
- Bit 11 If any interrupt source on the ADC201 occurs, then this bit is set to 1.

Table IX. Programmable Digital I/O Control Register (PIOCTRL)

Bit	Function	Reset Default
0	Programmable Digital I/O Direction Bit 0 (0 = Input, 1 = Output)	0
1	Programmable Digital I/O Direction Bit 1 (0 = Input, 1 = Output)	0
2	Programmable Digital I/O Direction Bit 2 (0 = Input, 1 = Output)	0
3	Programmable Digital I/O Direction Bit 3 (0 = Input, 1 = Output)	0
4	Programmable Digital I/O Direction Bit 4 (0 = Input, 1 = Output)	0
5	Programmable Digital I/O Direction Bit 5 (0 = Input, 1 = Output)	0
6	Programmable Digital I/O Bit 0 Interrupt (0 = Disable, 1 = Enable)	0
7	Programmable Digital I/O Bit 1 Interrupt (0 = Disable, 1 = Enable)	0
8	Programmable Digital I/O Bit 2 Interrupt (0 = Disable, 1 = Enable)	0
9	Programmable Digital I/O Bit 3 Interrupt (0 = Disable, 1 = Enable)	0
10	Programmable Digital I/O Bit 4 Interrupt (0 = Disable, 1 = Enable)	0
11	Programmable Digital I/O Bit 5 Interrupt (0 = Disable, 1 = Enable)	0

Bit 0–5 Sets corresponding Digital I/O bits as either input or output.

Bit 6–11 Configures Digital I/O Bits 0–5 as interrupt on change of state sources. Enabling interrupts for bits configured as output has no effect.

OUTLINE DIMENSIONS

Dimensions shown in inches and (mm).

**68-Lead Plastic Leaded Chip Carrier
(P-68A)**

