

12-BIT, 80 MSPS CommsADC™ ANALOG-TO-DIGITAL CONVERTER

FEATURES

- 80-MSPS Maximum Sample Rate
- 12-Bit Resolution
- No Missing Codes
- 360-mW Power Dissipation
- CMOS Technology
- On-Chip S/H
- 75 dB Spurious Free Dynamic Range at 100 MHz IF
- 1-GHz Bandwidth Differential Analog Input
- On-Chip References
- 2s Complement Digital Output
- 3.3-V Analog, 1.8-V Digital Supply
- 1.8 V–3.3 V I/O

APPLICATIONS

- Cellular Base Transceiver Station Receive Channel
 - IF Sampling Applications
 - TDMA: GSM, IS-136, EDGE/UWC-136
 - CDMA: IS-95, UMTS, CDMA2000
 - Wireless Local Loop
 - LMDS, MMDS
 - Wideband Baseband Receivers
- Medical Imaging:
 - Ultrasound
 - Magnetic Resonant Imaging
- Portable Instrumentation

DESCRIPTION

The ADS5410 is a high-speed, high-performance pipelined analog-to-digital converter with exceptionally low-noise and high spurious-free dynamic range. The ADS5410 high input bandwidth makes it ideal for IF subsampling solutions where digital I/Q demodulators are used. Its high dynamic range makes it well suited for GSM, IS-95, UMTS, and IS-136 digital receivers. Its linearity and low DNL make it ideal for medical imaging applications. Low power consumption makes the ADS5410 ideal for applications in compact pico- and micro-base stations and in portable designs.

FUNCTIONAL BLOCK DIAGRAM

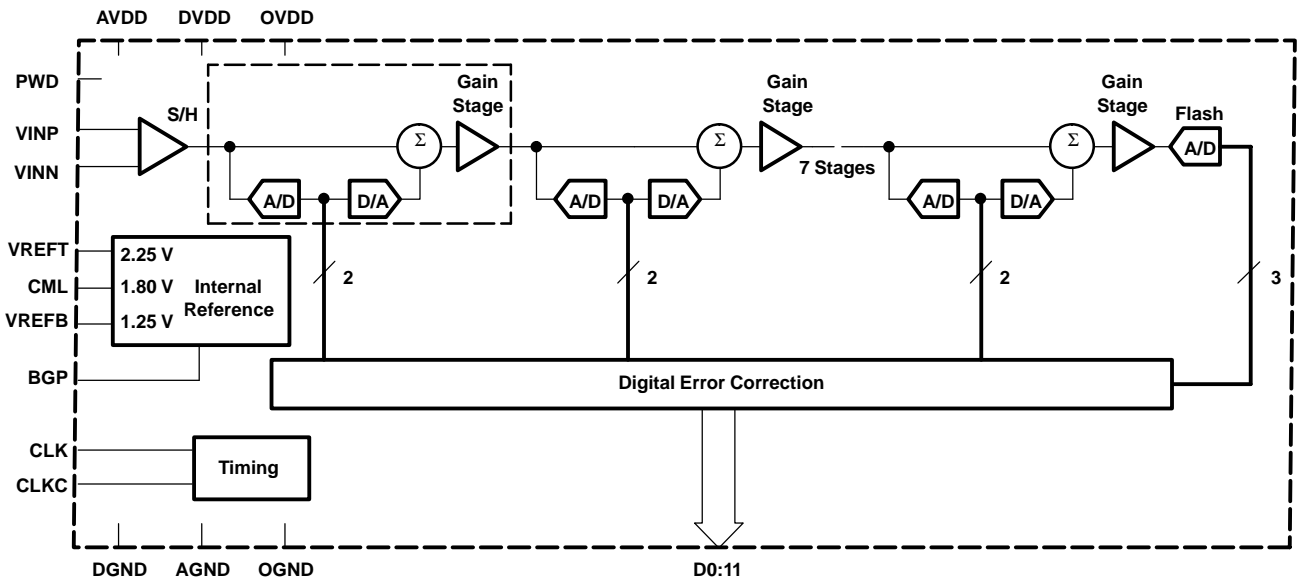

Please be aware that an important notice concerning availability, standard warranty, and use in critical applications of Texas Instruments semiconductor products and disclaimers thereto appears at the end of this data sheet.

CommsADC is a trademark of Texas Instruments.

ADS5410

SLAS346 – JUNE 2002

AVAILABLE OPTIONS

T _A	PACKAGE
	48-TQFP
-40°C to 85°C	ADS5410IPFB



These devices have limited built-in ESD protection. The leads should be shorted together or the device placed in conductive foam during storage or handling to prevent electrostatic damage to the MOS gates.

ABSOLUTE MAXIMUM RATINGS

over operating free-air temperature range unless otherwise noted⁽¹⁾

		ADS5410
Supply voltage range	AVDD	-0.3 V to 4 V
	DVDD	-0.3 V to 2.3 V
	OVDD	-0.3 V to 3.6 V
Voltage between	AGND and DGND	-0.3 to 0.3 V
	AVDD to DVDD	-3.3 V to 3.3 V
Digital input ⁽²⁾		-0.3 V to AVDD + 0.3 V
Digital data output		-0.3 V to OVDD + 0.3 V
Clamp current for digital input or output		±20 mA
Operating free-air temperature range, T _A		-40°C to 85°C

(1) Stresses beyond those listed under “absolute maximum ratings” may cause permanent damage to the device. These are stress ratings only, and functional operation of the device at these or any other conditions beyond those indicated under “recommended operating conditions” is not implied. Exposure to absolute-maximum-rated conditions for extended periods may affect device reliability.

(2) Measured with respect to AGND.

RECOMMENDED OPERATING CONDITIONS

	MIN	NOM	MAX	UNIT
SUPPLIES AND REFERENCES				
Operating free-air temperature, T _A	-40		85	°C
Analog supply voltage, V _(AVDD)	3	3.3	3.6	V
Digital supply voltage, V _(DVDD)	1.6	1.8	2	V
ANALOG INPUTS				
Output driver supply voltage, V _(OVDD)	1.6		3.6	V
Input common-mode voltage		CML ⁽¹⁾		V
Differential input voltage range		2		V _{pp}
CLOCK INPUTS CLK AND CLKC				
Sample rate, f _(s)	5		80	MHz
Differential input mode voltage input swing	0.4		3.3	V
Differential input common mode voltage		1.65		V
Single-ended mode high-level input voltage, V _{IH(s)}	2			V
Single-ended mode low-level input voltage, V _{IL(s)}			0.8	V
Clock pulse width high, t _{w(H)}	5.625	6.25		ns
Clock pulse width low, t _{w(L)}	5.625	6.25		ns

(1) See references section in DC ELECTRICAL CHARACTERISTICS table.

DC ELECTRICAL CHARACTERISTICS

over operating free-air temperature range, clock frequency = 80 MSPS, 50% clock duty cycle (AVDD = 3.3 V, DVDD = 1.8 V, OVDD = 1.8 V) (unless otherwise noted)

PARAMETER		TEST CONDITIONS	MIN	TYP	MAX	UNIT
DC Accuracy⁽¹⁾						
No missing codes		F _s = 88 MSPS ⁽²⁾	Assured			
DNL	Differential nonlinearity		-0.9	±0.5	1	LSB
INL	Integral nonlinearity		-2	±1.5	2	LSB
E _O	Offset error		3			mV
E _G	Gain error		0.5			%FS
Power Supply						
I _I (AVDD)	Analog supply current	F _s = 80 MSPS, A _I = FS, f _i = 2 MHz	105			mA
I _I (DVDD)	Digital supply current		1			
I _I (OVDD)	Digital output driver supply current		3.5			
Power dissipation			360	450	mW	
Power down dissipation		PWDN = high	30	45	mW	
PSRR	Power supply rejection ratio		±0.3			mV/V
References						
V _{ref} (VREFB)	Reference bottom		1.1	1.25	1.4	V
V _{ref} (VREFT)	Reference top		2.1	2.25	2.4	V
V _{REFT} - V _{REFB}			1.06			V
V _{REFT} - V _{REFB} variation (6σ)			0.06			V
V _{OC} (CML)	Common mode output voltage		1.8			V
Digital Inputs (PWD)						
I _{IH}	High-level input current	V _I = 1.6 V	-10	10		μA
I _{IL}	Low-level input current	V _I = 0.3 V	-10	10		μA
V _{IH}	High-level input voltage		1.8			V
V _{IL}	Low-level input voltage		0.8			V
Digital Outputs						
V _{OH}	High-level output voltage	I _{OH} = -50 μA	1.4			V
V _{OL}	Low-level output voltage	I _{OL} = 50 μA	0.4			V

(1) F_s = 80 MSPS, sinewave input, f_i = 2 MHz

(2) Speed margin test

ADS5410

SLAS346 – JUNE 2002

AC ELECTRICAL CHARACTERISTICS

over operating free-air temperature range, clock frequency = 80 MSPS, 50% clock duty cycle (AVDD = 3.3 V, DVDD = 1.8 V, OVDD = 1.8 V) (unless otherwise noted)

PARAMETER		TEST CONDITIONS	MIN	TYP	MAX	UNIT
SFDR	Spurious free dynamic range, $A_i = -1$ dBFS (no exceptions)	$f_i = 2.2$ MHz		76		dBc
		$f_i = 17.4$ MHz	72	76		
		$f_i = 31$ MHz		76		
		$f_i = 70$ MHz		72		
		$f_i = 150$ MHz		70		
HD3	Third order harmonic, $A_i = -1$ dBFS	$f_i = 2.2$ MHz		84		dBc
		$f_i = 17.4$ MHz		84		
		$f_i = 31$ MHz		86		
		$f_i = 70$ MHz		79		
		$f_i = 150$ MHz		70		
HD2	Second order harmonic, $A_i = -1$ dBFS	$f_i = 2.2$ MHz		81		dBc
		$f_i = 17$ MHz		80		
		$f_i = 31$ MHz		90		
		$f_i = 70$ MHz		88		
		$f_i = 150$ MHz		75		
SNR	Signal-to-noise ratio, $A_i = -1$ dBFS	$f_i = 2.2$ MHz		67		dB
		$f_i = 17.4$ MHz	63	66		
		$f_i = 31$ MHz		65		
		$f_i = 70$ MHz		62		
		$f_i = 150$ MHz		57		
SINAD	Signal-to-noise and distortion, $A_i = -1$ dBFS	$f_i = 2.2$ MHz		66		dB
		$f_i = 17.4$ MHz	62.5	65		
		$f_i = 31$ MHz		64		
		$f_i = 70$ MHz		61		
		$f_i = 150$ MHz		56		
Two tone IMD rejection, $A_{1,2} = -7$ dBFS		$f_1 = 15.2$ MHz, $f_2 = 15.9$ MHz		77		dBc
Track mode bandwidth		-3 dB BW with -3dBFS input at low frequency		1		GHz

PIN ASSIGNMENTS

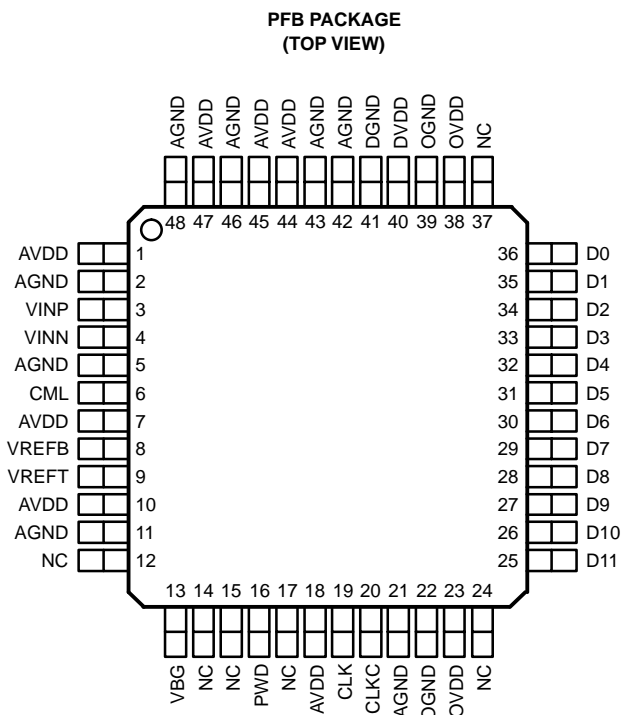

Terminal Functions

TERMINAL NAME	TERMINAL NO.	I/O	DESCRIPTION
AVDD	1, 7, 10, 18, 44, 45, 47	I	Analog power supply
AGND	2, 5, 11, 21, 42, 43, 46, 48	I	Analog ground
CLK	19	I	Clock input
CLKC	20	I	Complementary clock input
CML	6	O	Common-mode output voltage
D11–D0	25–36	O	Digital outputs, D11 is most significant data bit, D0 is least significant data bit.
DGND	41	I	Digital ground
DVDD	40	I	Digital power supply
NC	12, 14, 15, 17, 24, 37		No connection
OGND	22, 39	I	Digital driver ground
OVDD	23, 38	I	Digital driver power
PWD	16	I	Power down, active high
VBG	13	O	Bandgap voltage output
VINN	4	I	Complementary analog input
VINP	3	I	Analog input
VREFB	8	O	Reference bottom
VREFT	9	O	Reference top

ADS5410

SLAS346 – JUNE 2002

TIMING DIAGRAMS

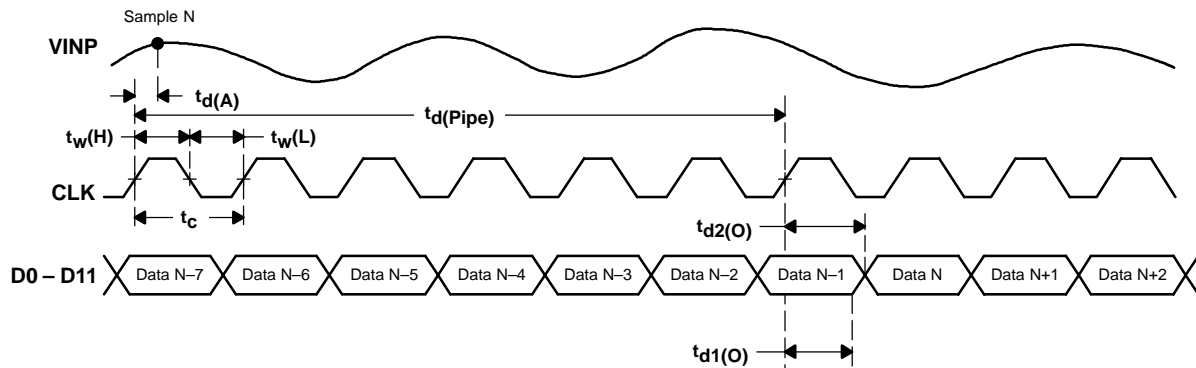

Figure 1. ADS5410 Timing Diagram

TIMING CHARACTERISTICS

		MIN	TYP	MAX	UNIT
$t_d(A)$	Aperture delay		2		ns
	Aperture jitter		1.5		ps
$t_{d1}(O)$	Output propagation delay (beginning of transition)		6		ns
$t_{d2}(O)$	Output propagation delay (data stable)		10		ns
$t_d(Pipe)$	Latency		6		Clock cycles

TYPICAL CHARACTERISTICS†

SPECTRAL PERFORMANCE

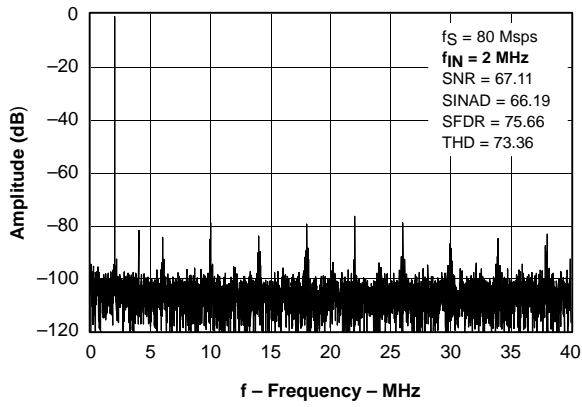

Figure 2

SPECTRAL PERFORMANCE

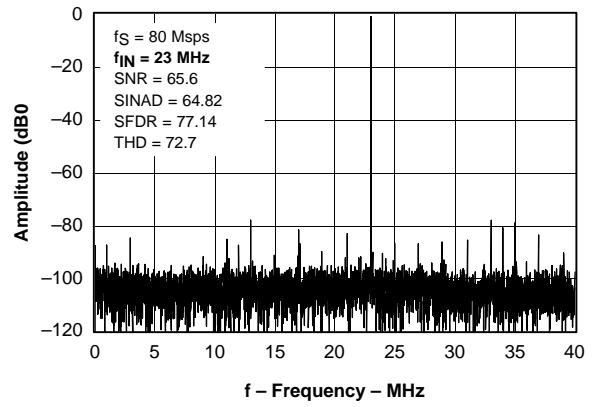

Figure 3

SPECTRAL PERFORMANCE

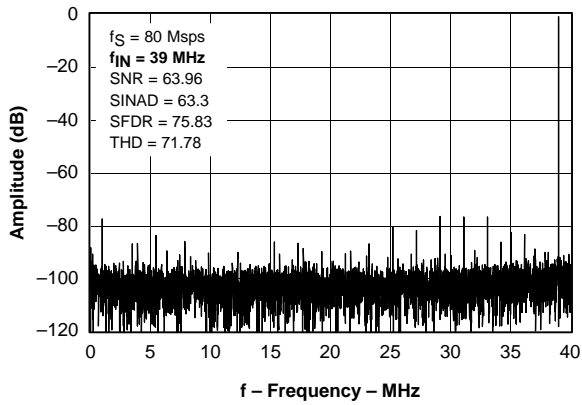

Figure 4

SPECTRAL PERFORMANCE

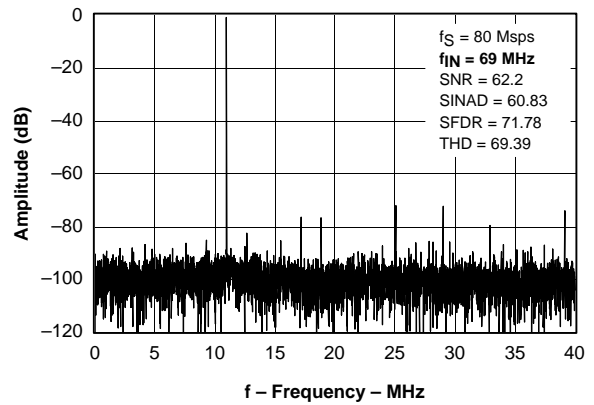

Figure 5

SPECTRAL PERFORMANCE

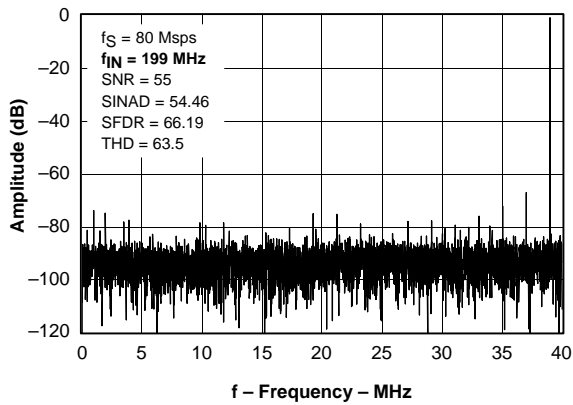

Figure 6

SPECTRAL PERFORMANCE

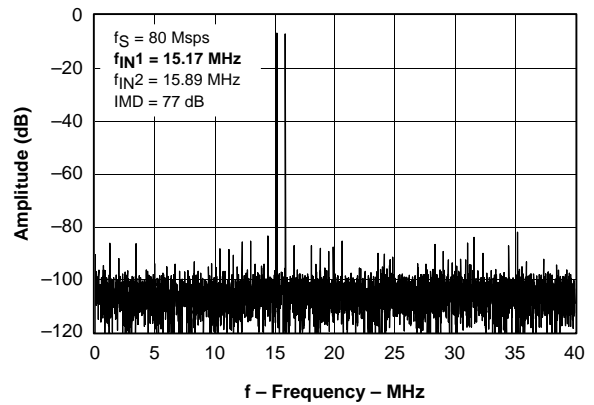
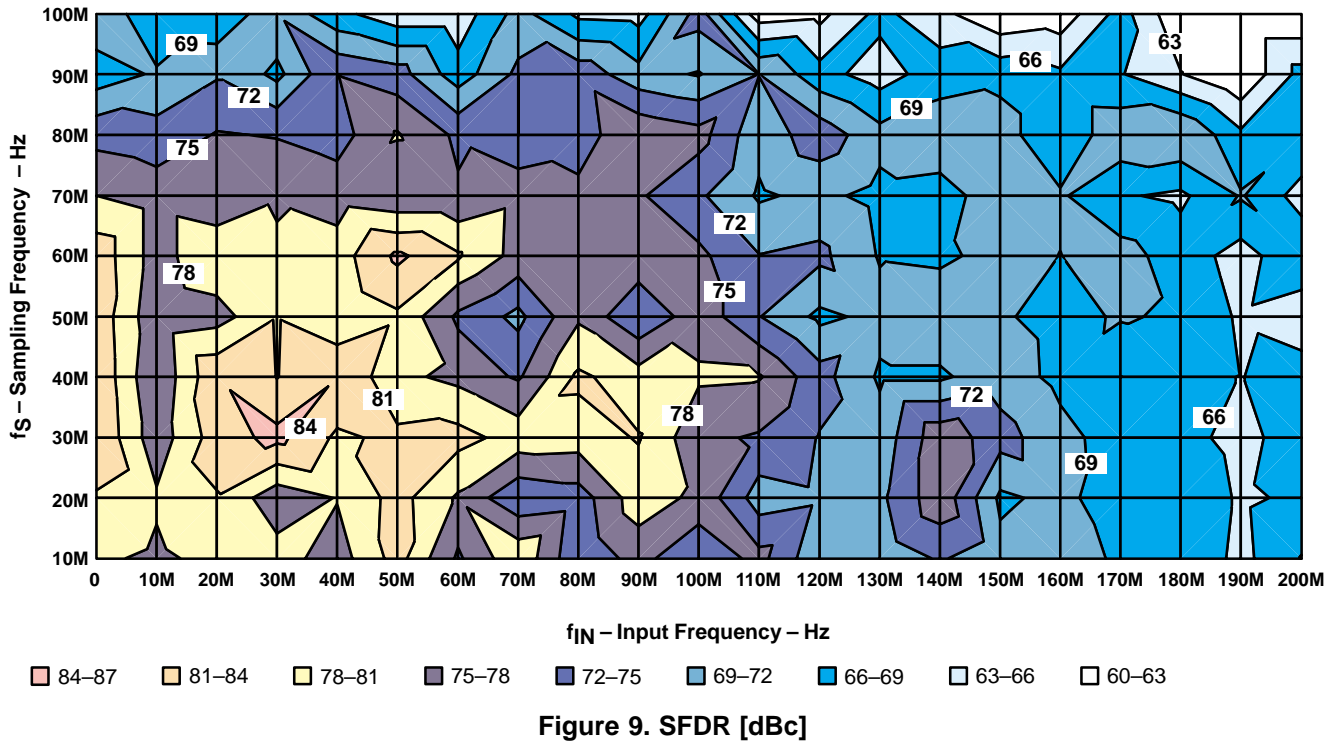
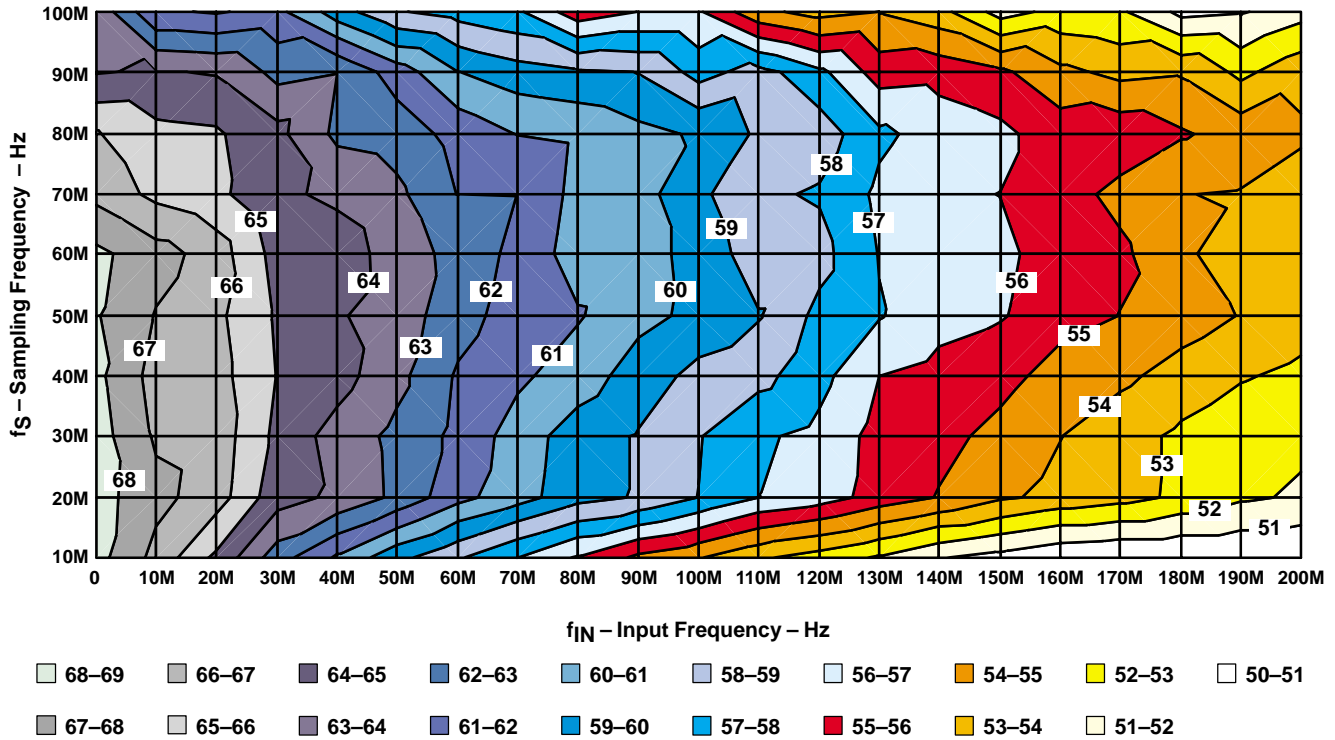

Figure 7

†50% duty cycle. $AV_{DD} = 3.3$ V, $DV_{DD} = 1.8$ V, $DV_{DD} = 1.8$ V

TYPICAL CHARACTERISTICS†



†50% duty cycle. AV_{DD} = 3.3 V, DV_{DD} = 1.8 V, DV_{DD} = 1.8 V

TYPICAL CHARACTERISTICS†

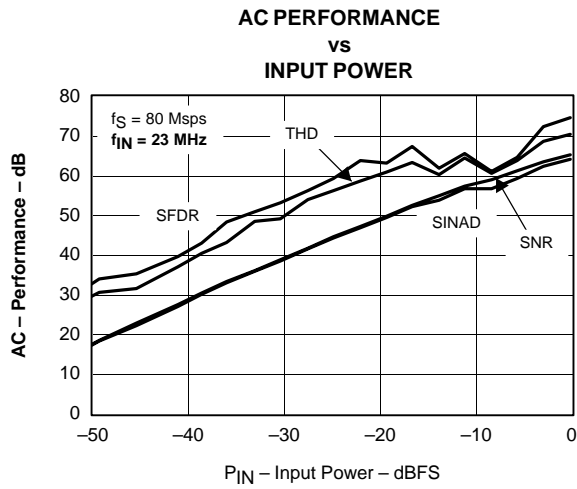

Figure 10

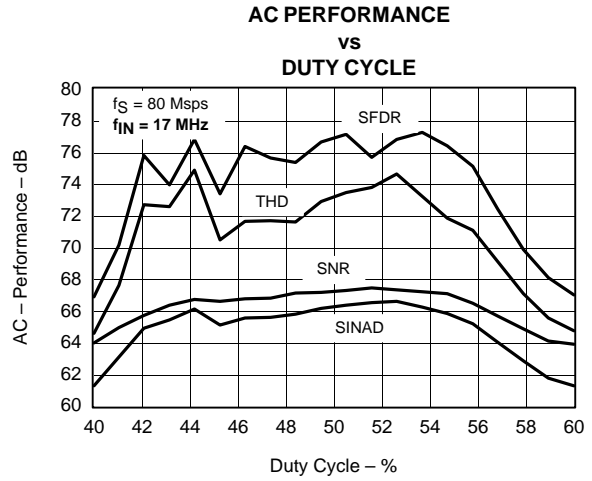

Figure 11

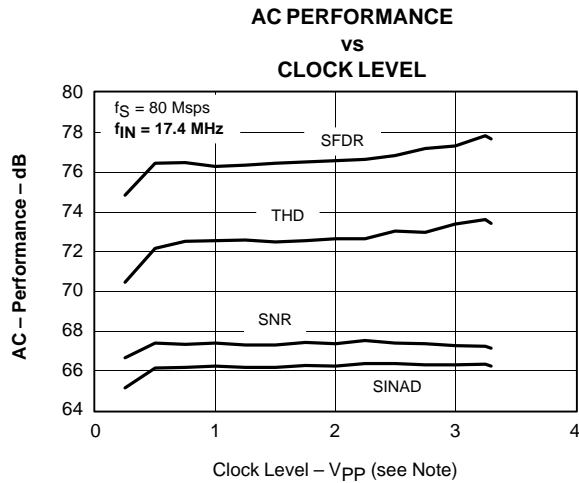

Figure 12

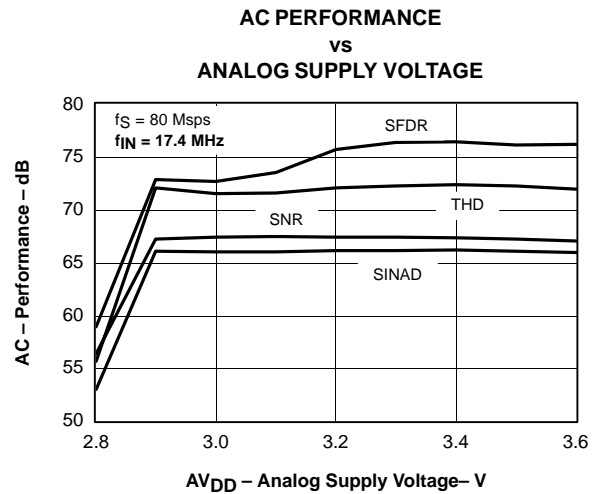

Figure 13

NOTE: Voltage peak to peak in pin 19 or 20. Multiply by 2 to obtain differential peak to peak.

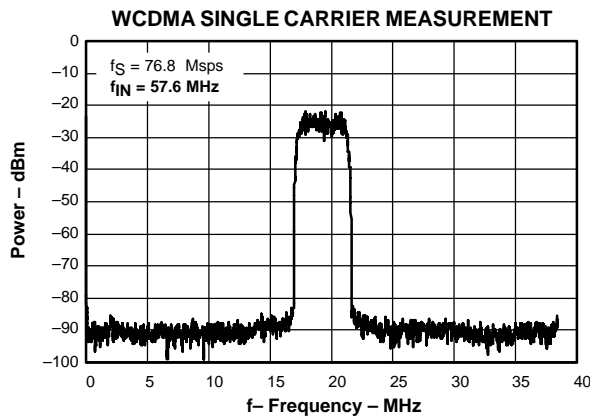

Figure 14

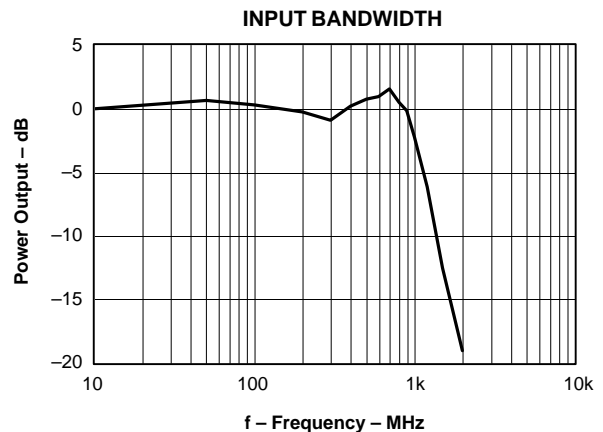

Figure 15

†50% duty cycle. $AV_{DD} = 3.3 \text{ V}$, $DV_{DD} = 1.8 \text{ V}$, $DV_{DD} = 1.8 \text{ V}$

TYPICAL CHARACTERISTICS†

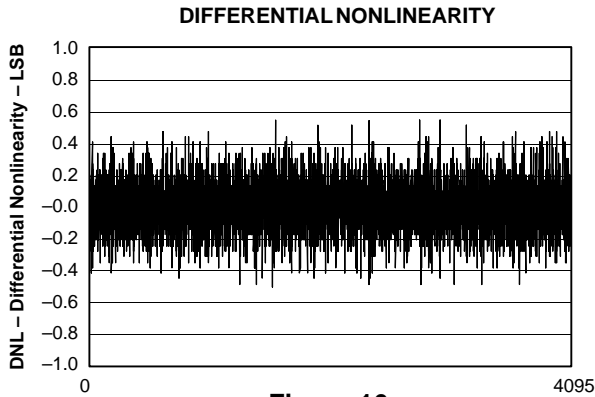

Figure 16

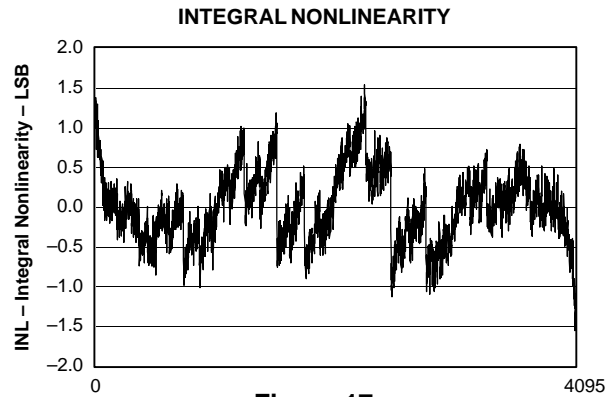

Figure 17

†50% duty cycle. AVDD = 3.3 V, DVDD = 1.8 V, DVDD = 1.8 V

EQUIVALENT CIRCUITS

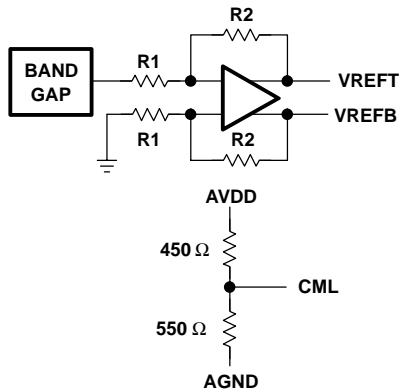

Figure 18. References

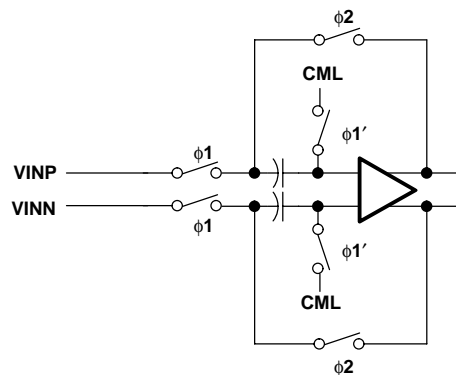

Figure 19. Analog Input Stage

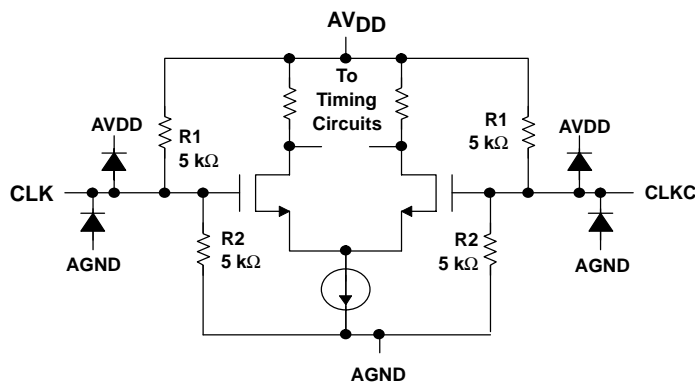

Figure 20. Clock Inputs

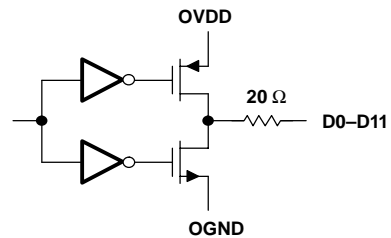

Figure 21. Digital Outputs

APPLICATION INFORMATION

CONVERTER OPERATION

The ADS5410 is a 12 bit ADC. Its low power (360 mW) at 80 Msps and high sampling rate is achieved using a state-of-the-art switched capacitor pipeline architecture built on an advanced low-voltage CMOS process. The ADS5410 analog core primarily operates from a 3.3-V supply consuming most of the power. The digital core operates from 1.8-V supply. A TPS76318 can be used to obtain the 1.8 V from the 3.3-V AVDD supply, if 1.8 V is not a supply already available in the design. For additional interfacing flexibility, the digital output supply (OVDD) can be set from 1.6 V to 3.6 V. The ADC core consists of 10 pipeline stages and one flash ADC. Each of the stages produces 1.5 bits per stage. Both the rising and the falling clock edges are utilized to propagate the sample through the pipeline every half clock, for a total of six clock cycles.

ANALOG INPUTS

The analog input for the ADS5410 consists of a differential track-and-hold amplifier implemented using a switched capacitor technique, shown in Figure 19. This differential input topology, along with closely matched capacitors, produces a high level of ac-performance up to high sampling rates.

The ADS5410 requires each of the analog inputs (AIN+, AIN-) to be externally biased around the common mode level of the internal circuitry (CML, pin 6). After the connection of CML to the inputs, as shown in the diagrams below, the common mode level of the signal is between 1.6 V and 1.9 V depending on several factors, but this variation does not affect performance. For a full scale differential input, each of the differential lines of the input signal (pins 3 and 4) swings symmetrically between CML+0.5 V and CML-0.5 V. The maximum swing is determined by the two reference voltages, the top reference (REFT), and the bottom reference (REFB).

Although the inputs can be driven in single-ended configuration, the ADS5410 obtains optimum performance when the analog inputs are driven differentially. The circuit in Figure 22 shows one possible configuration.

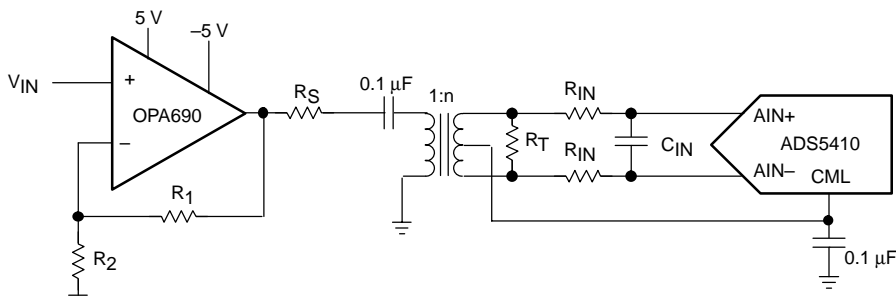

Figure 23. Converting a Single-Ended Input Signal Into a Differential Signal Using an RF Transformer

The single ended signal is fed to the primary of an RF transformer. Since the input signal must be biased around the common mode voltage of the internal circuitry, the common mode (CML) reference from the ADS5410 is connected to the center-tap of the secondary. To ensure a steady low noise CML reference, the best performance is obtained when the CML output is connected to ground with a 0.1-μF and 0.01-μF low inductance capacitor.

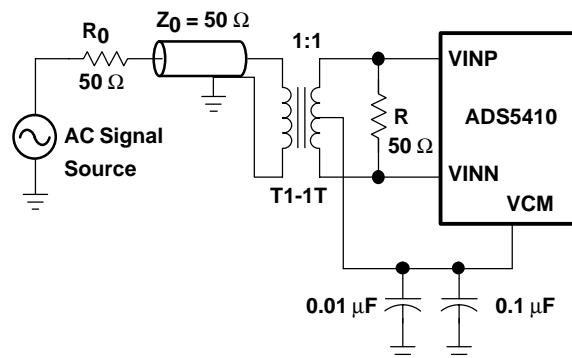

Figure 22. Driving the ADS5410 Analog Input With Impedance Matched Transmission Line

If it is necessary to buffer or apply a gain to the incoming analog signal, it is possible to combine a single-ended amplifier with an RF transformer as shown in Figure 23. TI offers a wide selection of operational amplifiers, as the THS3001, the OPA687, or the OPA690 that can be selected depending on the application. R_{in} and C_{in} can be placed to isolate the source from the switching inputs of the ADC and to implement a low pass RC filter to limit the input noise in the ADC. Although not needed, it is recommended to lay out the circuit with placement for those 3 components, which allows fine tune of the prototype if necessary. Nevertheless, any mismatch between the differential lines of the input produces a degradation in performance at high input frequencies, mainly characterized by an increase in the even harmonics. In this case, special care should be taken keeping as much electrical symmetry as possible between both inputs. This includes shorting R_{in} and leaving C_{in} unpopulated.

ADS5410

SLAS346 – JUNE 2002

Another possibility is the use of differential input/output amplifiers that can simplify the driver circuit for applications requiring input dc coupling. Flexible in their configurations (Figure 24), such amplifiers can be used for single ended to differential conversion, for signal amplification, and also for filtering prior to the ADC.

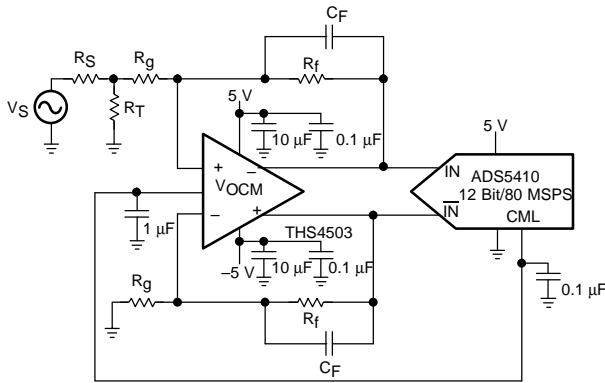

Figure 24. Using the THS4503 With the ADS5410

REFERENCE CIRCUIT

The ADS5410 has its own internal reference generation saving external circuitry in the design. For optimum performance, it is best to connect both VREFB and VREFT to ground with a 1- μ F and 0.1- μ F decoupling capacitors in parallel, and a 0.1- μ F capacitor between both pins (Figure 25). The band-gap voltage output is not a voltage source, and is used internally by the ADS5410. However, it should be decoupled to ground with a 1- μ F and 0.01- μ F capacitor, in parallel.

CLOCK INPUTS

The ADS5410 clock input can be driven with either a differential clock signal or a single ended clock input with little or no difference in performance between the single-ended and differential-input configurations. The common mode of the clock inputs is set internally to $AV_{DD}/2$ using 5-k Ω resistors (Figure 20). The clock input should be either a sine wave or a square wave having a 50% duty cycle.

When driven with a single-ended CMOS clock input, it is best to connect the CLK input to ground with a 0.01- μ F capacitor (see Figure 26) while CLK is ac couple with 0.01 μ F to the clock source.

The ADS5410 clock input can also be driven differentially, reducing susceptibility to common mode noise. In this case, it is best to connect both clock inputs to the differential input clock signal with 0.01- μ F capacitors (see Figure 27). The differential input swing can vary between 1 V and 6 V with little or no performance degradation (see Figure 12).

POWER DOWN

When power down (pin 16) is tight to AV_{DD} , the device reduces its power consumption until a typical value of 30 mW. Connecting this pin to GND enables the device operation.

DIGITAL OUTPUTS

The ADS5410 output format is 2s complement. The voltage level of the outputs can be adjusted by setting the OV_{DD} voltage between 1.65 V and 3.6 V, allowing for direct interface to several digital families. For better performance, customers should select the smaller output swing required in the application. To improve the performance, mainly on the higher output voltage swing configurations, the addition of a series resistor at the outputs, limiting peak currents, is recommended. The maximum value of this resistor is limited by the maximum data rate of the application. Values between 0 Ω and 200 Ω are usual. Also, limiting the length of the external traces is a good practice.

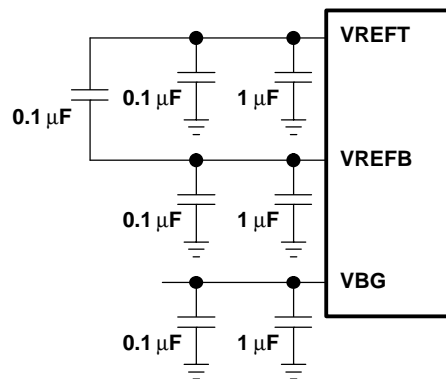

Figure 25. Internal Reference Usage

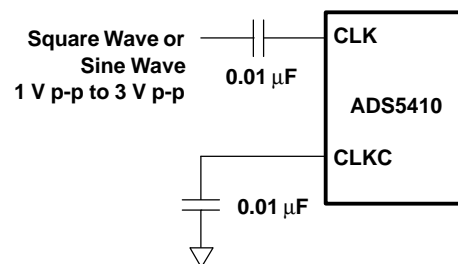

Figure 26. AC-Coupled Single-Ended Clock Input

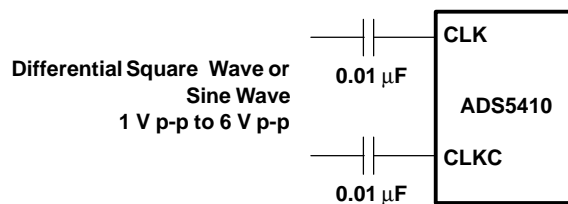

Figure 27. AC-Coupled Differential Clock Input

DEFINITION OF SPECIFICATIONS

Analog Bandwidth

The analog input frequency at which the spectral power of the fundamental frequency (as determined by the FFT analysis) is reduced by 3 dB.

Aperture Delay

The delay between the 50% point of the rising edge of the CLK command and the instant at which the analog input is sampled.

Aperture Uncertainty (Jitter)

The sample-to-sample variation in aperture delay.

Differential Nonlinearity

The average deviation of any single LSB transition at the digital output from an ideal 1 LSB step at the analog input.

Integral Nonlinearity

The deviation of the transfer function from a reference line measured in fractions of 1 LSB using a *best straight line* determined by a least square curve fit.

Clock Pulse Width/Duty Cycle

Pulse width high is the minimum amount of time that the CLK pulse should be left in logic 1 state to achieve rated performance; pulse width low is the minimum time CLK pulse should be left in low state. At a given clock rate, these specs define an acceptable clock duty cycles.

Maximum Conversion Rate

The clock rate at which parametric testing is performed.

Offset Error

The difference between the voltage at which the digital output transitions from midscale to one LSB above midscale, and the ideal voltage at which this transition should occur

Output Propagation Delay ($t_{d2(O)}$)

The delay between the 50% point of the rising edge of CLK command and the time when all output data bits are within valid logic levels.

Power Supply Rejection Ratio

The ratio of a change in input offset voltage to a change in power supply voltage.

Signal-to-Noise and Distortion (SINAD)

The ratio of the rms signal amplitude (set 1 dB below full scale) to rms value of the sum of all other spectral components, including harmonics but excluding dc.

Signal-to-Noise Ratio (Without Harmonics)

The ratio of the rms signal amplitude (set at 1 dB below full scale) to the rms value of the the sum of all other spectral components, excluding the first five harmonics and dc.

Spurious-Free Dynamic Range

The ratio of the rms signal amplitude to the rms value of the peak spurious spectral component. The peak spurious component may or may not be a harmonic and it is reported in dBc.

Two-Tone Intermodulation Distortion Rejection

The ratio of the rms value of either input tone to the rms value of the worst third order intermodulation product reported in dBc

PACKAGING INFORMATION

Orderable Device	Status ⁽¹⁾	Package Type	Package Drawing	Pins	Package Qty	Eco Plan ⁽²⁾	Lead/Ball Finish	MSL Peak Temp ⁽³⁾
ADS5410IPFB	ACTIVE	TQFP	PFB	48	250	Green (RoHS & no Sb/Br)	CU NIPDAU	Level-2-260C-1 YEAR
ADS5410IPFBG4	ACTIVE	TQFP	PFB	48	250	Green (RoHS & no Sb/Br)	CU NIPDAU	Level-2-260C-1 YEAR
CDCE72010RGCR	ACTIVE	VQFN	RGC	64	2000	Green (RoHS & no Sb/Br)	CU NIPDAU	Level-3-260C-168 HR
CDCE72010RGCRG4	ACTIVE	VQFN	RGC	64	2000	Green (RoHS & no Sb/Br)	CU NIPDAU	Level-3-260C-168 HR
CDCE72010RGCT	ACTIVE	VQFN	RGC	64	250	Green (RoHS & no Sb/Br)	CU NIPDAU	Level-3-260C-168 HR
CDCE72010RGCTG4	ACTIVE	VQFN	RGC	64	250	Green (RoHS & no Sb/Br)	CU NIPDAU	Level-3-260C-168 HR

⁽¹⁾ The marketing status values are defined as follows:

ACTIVE: Product device recommended for new designs.

LIFEBUY: TI has announced that the device will be discontinued, and a lifetime-buy period is in effect.

NRND: Not recommended for new designs. Device is in production to support existing customers, but TI does not recommend using this part in a new design.

PREVIEW: Device has been announced but is not in production. Samples may or may not be available.

OBSOLETE: TI has discontinued the production of the device.

⁽²⁾ Eco Plan - The planned eco-friendly classification: Pb-Free (RoHS), Pb-Free (RoHS Exempt), or Green (RoHS & no Sb/Br) - please check <http://www.ti.com/productcontent> for the latest availability information and additional product content details.

TBD: The Pb-Free/Green conversion plan has not been defined.

Pb-Free (RoHS): TI's terms "Lead-Free" or "Pb-Free" mean semiconductor products that are compatible with the current RoHS requirements for all 6 substances, including the requirement that lead not exceed 0.1% by weight in homogeneous materials. Where designed to be soldered at high temperatures, TI Pb-Free products are suitable for use in specified lead-free processes.

Pb-Free (RoHS Exempt): This component has a RoHS exemption for either 1) lead-based flip-chip solder bumps used between the die and package, or 2) lead-based die adhesive used between the die and leadframe. The component is otherwise considered Pb-Free (RoHS compatible) as defined above.

Green (RoHS & no Sb/Br): TI defines "Green" to mean Pb-Free (RoHS compatible), and free of Bromine (Br) and Antimony (Sb) based flame retardants (Br or Sb do not exceed 0.1% by weight in homogeneous material)

⁽³⁾ MSL, Peak Temp. -- The Moisture Sensitivity Level rating according to the JEDEC industry standard classifications, and peak solder temperature.

Important Information and Disclaimer:The information provided on this page represents TI's knowledge and belief as of the date that it is provided. TI bases its knowledge and belief on information provided by third parties, and makes no representation or warranty as to the accuracy of such information. Efforts are underway to better integrate information from third parties. TI has taken and continues to take reasonable steps to provide representative and accurate information but may not have conducted destructive testing or chemical analysis on incoming materials and chemicals. TI and TI suppliers consider certain information to be proprietary, and thus CAS numbers and other limited information may not be available for release.

In no event shall TI's liability arising out of such information exceed the total purchase price of the TI part(s) at issue in this document sold by TI to Customer on an annual basis.

TAPE AND REEL INFORMATION
REEL DIMENSIONS

TAPE DIMENSIONS

A0	Dimension designed to accommodate the component width
B0	Dimension designed to accommodate the component length
K0	Dimension designed to accommodate the component thickness
W	Overall width of the carrier tape
P1	Pitch between successive cavity centers

TAPE AND REEL INFORMATION

*All dimensions are nominal

Device	Package Type	Package Drawing	Pins	SPQ	Reel Diameter (mm)	Reel Width W1 (mm)	A0 (mm)	B0 (mm)	K0 (mm)	P1 (mm)	W (mm)	Pin1 Quadrant
CDCE72010RGCR	VQFN	RGC	64	2000	330.0	16.4	9.3	9.3	1.5	12.0	16.0	Q2
CDCE72010RGCT	VQFN	RGC	64	250	330.0	16.4	9.3	9.3	1.5	12.0	16.0	Q2

TAPE AND REEL BOX DIMENSIONS

*All dimensions are nominal

Device	Package Type	Package Drawing	Pins	SPQ	Length (mm)	Width (mm)	Height (mm)
CDCE72010RGCR	VQFN	RGC	64	2000	336.6	336.6	28.6
CDCE72010RGCT	VQFN	RGC	64	250	336.6	336.6	28.6

IMPORTANT NOTICE

Texas Instruments Incorporated and its subsidiaries (TI) reserve the right to make corrections, modifications, enhancements, improvements, and other changes to its products and services at any time and to discontinue any product or service without notice. Customers should obtain the latest relevant information before placing orders and should verify that such information is current and complete. All products are sold subject to TI's terms and conditions of sale supplied at the time of order acknowledgment.

TI warrants performance of its hardware products to the specifications applicable at the time of sale in accordance with TI's standard warranty. Testing and other quality control techniques are used to the extent TI deems necessary to support this warranty. Except where mandated by government requirements, testing of all parameters of each product is not necessarily performed.

TI assumes no liability for applications assistance or customer product design. Customers are responsible for their products and applications using TI components. To minimize the risks associated with customer products and applications, customers should provide adequate design and operating safeguards.

TI does not warrant or represent that any license, either express or implied, is granted under any TI patent right, copyright, mask work right, or other TI intellectual property right relating to any combination, machine, or process in which TI products or services are used. Information published by TI regarding third-party products or services does not constitute a license from TI to use such products or services or a warranty or endorsement thereof. Use of such information may require a license from a third party under the patents or other intellectual property of the third party, or a license from TI under the patents or other intellectual property of TI.

Reproduction of TI information in TI data books or data sheets is permissible only if reproduction is without alteration and is accompanied by all associated warranties, conditions, limitations, and notices. Reproduction of this information with alteration is an unfair and deceptive business practice. TI is not responsible or liable for such altered documentation. Information of third parties may be subject to additional restrictions.

Resale of TI products or services with statements different from or beyond the parameters stated by TI for that product or service voids all express and any implied warranties for the associated TI product or service and is an unfair and deceptive business practice. TI is not responsible or liable for any such statements.

TI products are not authorized for use in safety-critical applications (such as life support) where a failure of the TI product would reasonably be expected to cause severe personal injury or death, unless officers of the parties have executed an agreement specifically governing such use. Buyers represent that they have all necessary expertise in the safety and regulatory ramifications of their applications, and acknowledge and agree that they are solely responsible for all legal, regulatory and safety-related requirements concerning their products and any use of TI products in such safety-critical applications, notwithstanding any applications-related information or support that may be provided by TI. Further, Buyers must fully indemnify TI and its representatives against any damages arising out of the use of TI products in such safety-critical applications.

TI products are neither designed nor intended for use in military/aerospace applications or environments unless the TI products are specifically designated by TI as military-grade or "enhanced plastic." Only products designated by TI as military-grade meet military specifications. Buyers acknowledge and agree that any such use of TI products which TI has not designated as military-grade is solely at the Buyer's risk, and that they are solely responsible for compliance with all legal and regulatory requirements in connection with such use.

TI products are neither designed nor intended for use in automotive applications or environments unless the specific TI products are designated by TI as compliant with ISO/TS 16949 requirements. Buyers acknowledge and agree that, if they use any non-designated products in automotive applications, TI will not be responsible for any failure to meet such requirements.

Following are URLs where you can obtain information on other Texas Instruments products and application solutions:

Products

Audio	www.ti.com/audio
Amplifiers	amplifier.ti.com
Data Converters	dataconverter.ti.com
DLP® Products	www.dlp.com
DSP	dsp.ti.com
Clocks and Timers	www.ti.com/clocks
Interface	interface.ti.com
Logic	logic.ti.com
Power Mgmt	power.ti.com
Microcontrollers	microcontroller.ti.com
RFID	www.ti-rfid.com
OMAP Mobile Processors	www.ti.com/omap
Wireless Connectivity	www.ti.com/wirelessconnectivity

Applications

Automotive and Transportation	www.ti.com/automotive
Communications and Telecom	www.ti.com/communications
Computers and Peripherals	www.ti.com/computers
Consumer Electronics	www.ti.com/consumer-apps
Energy and Lighting	www.ti.com/energy
Industrial	www.ti.com/industrial
Medical	www.ti.com/medical
Security	www.ti.com/security
Space, Avionics and Defense	www.ti.com/space-avionics-defense
Video and Imaging	www.ti.com/video

TI E2E Community Home Page

e2e.ti.com

Mailing Address: Texas Instruments, Post Office Box 655303, Dallas, Texas 75265
Copyright © 2012, Texas Instruments Incorporated