

# AM26LV32C, AM26LV32I

## LOW-VOLTAGE HIGH-SPEED QUADRUPLE DIFFERENTIAL LINE RECEIVER

SLLS202E – MAY 1995 – REVISED JUNE 2005

- Switching Rates up to 32 MHz
- Operates From Single 3.3-V Supply
- Ultra-Low Power Dissipation . . . 27 mW Typ
- Open-Circuit, Short-Circuit, and Terminated Fail-Safe
- –0.3-V to 5.5-V Common-Mode Range With  $\pm 200$ -mV Sensitivity
- Accepts 5-V Logic Inputs With 3.3-V  $V_{CC}$
- Input Hysteresis . . . 50 mV Typ
- 235 mW With Four Receivers at 32 MHz
- Pin-to-Pin Compatible With AM26C32, AM26LS32, and MB570

D OR NS† PACKAGE  
(TOP VIEW)

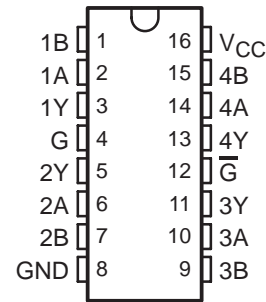

### description/ordering information

The AM26LV32, BiCMOS, quadruple, differential line receiver with 3-state outputs is designed to be similar to TIA/EIA-422-B and ITU Recommendation V.11 receivers with reduced common-mode voltage range due to reduced supply voltage.

The device is optimized for balanced bus transmission at switching rates up to 32 MHz. The enable function is common to all four receivers and offers a choice of active-high or active-low inputs. The 3-state outputs permit connection directly to a bus-organized system. Each device features receiver high input impedance and input hysteresis for increased noise immunity, and input sensitivity of  $\pm 200$  mV over a common-mode input voltage range from –0.3 V to 5.5 V. When the inputs are open circuited, the outputs are in the high logic state. This device is designed using the Texas Instruments (TI™) proprietary LinIMPACT-C60™ technology, facilitating ultra-low power consumption without sacrificing speed.

This device offers optimum performance when used with the AM26LV31 quadruple line drivers.

The AM26LV32C is characterized for operation from 0°C to 70°C. The AM26LV32I is characterized for operation from –45°C to 85°C.

### ORDERING INFORMATION

T <sub>A</sub>	PACKAGE†		ORDERABLE PART NUMBER	TOP-SIDE MARKING
0°C to 70°C	D	Tape and reel	AM26LV32CDG4	AM26LV32C
			AM26LV32CDR	
			AM26LV32CDRG4	
	NS	Tube	AM26LV32CNS	26LV32
AM26LV32CNSR				
–40°C to 85°C	SOP – D	Tube	AM26LV32ID	AM26LV32I
			AM26LV32IDR	
	SOP – NS	Tube	AM26LV32INS	26LV32I
			AM26LV32INSR	

† Package drawings, standard packing quantities, thermal data, symbolization, and PCB design guidelines are available at [www.ti.com/sc/package](http://www.ti.com/sc/package).



Please be aware that an important notice concerning availability, standard warranty, and use in critical applications of Texas Instruments semiconductor products and disclaimers thereto appears at the end of this data sheet.

LinIMPACT-C60 and TI are trademarks of Texas Instruments.

PRODUCTION DATA information is current as of publication date. Products conform to specifications per the terms of Texas Instruments standard warranty. Production processing does not necessarily include testing of all parameters.



POST OFFICE BOX 655303 • DALLAS, TEXAS 75265

Copyright © 2005, Texas Instruments Incorporated

# AM26LV32C, AM26LV32I LOW-VOLTAGE HIGH-SPEED QUADRUPLE DIFFERENTIAL LINE RECEIVER

SLLS202E – MAY 1995 – REVISED JUNE 2005

FUNCTION TABLE  
(each receiver)

DIFFERENTIAL INPUT	ENABLES		OUTPUT
	G	$\overline{G}$	
$V_{ID} \geq 0.2 V$	H X	X L	H H
$-0.2 V < V_{ID} < 0.2 V$	H X	X L	? ?
$V_{ID} \leq -0.2 V$	H X	X L	L L
Open, shorted, or terminated†	H X	X L	H H
X	L	H	Z

H = high level, L = low level, X = irrelevant,  
Z = high impedance (off), ? = indeterminate  
† See application information attached.

### logic symbol‡

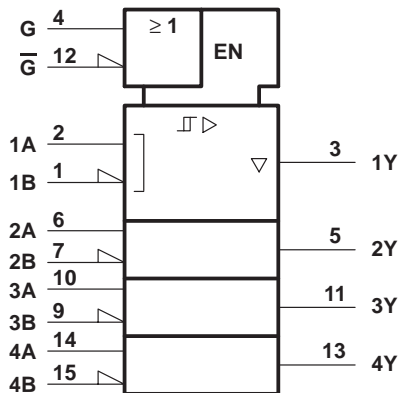

‡ This symbol is in accordance with ANSI/IEEE Std 91-1984 and IEC Publication 617-12.

### logic diagram (positive logic)

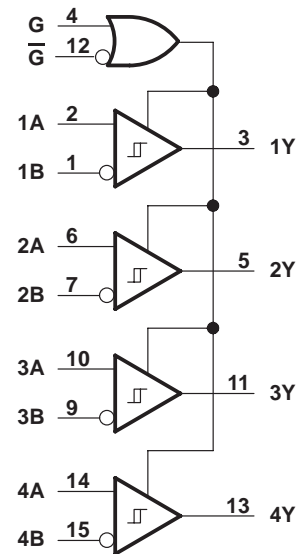

# AM26LV32C, AM26LV32I

## LOW-VOLTAGE HIGH-SPEED QUADRUPLE DIFFERENTIAL LINE RECEIVER

SLLS202E – MAY 1995 – REVISED JUNE 2005

### schematics of equivalent inputs and outputs

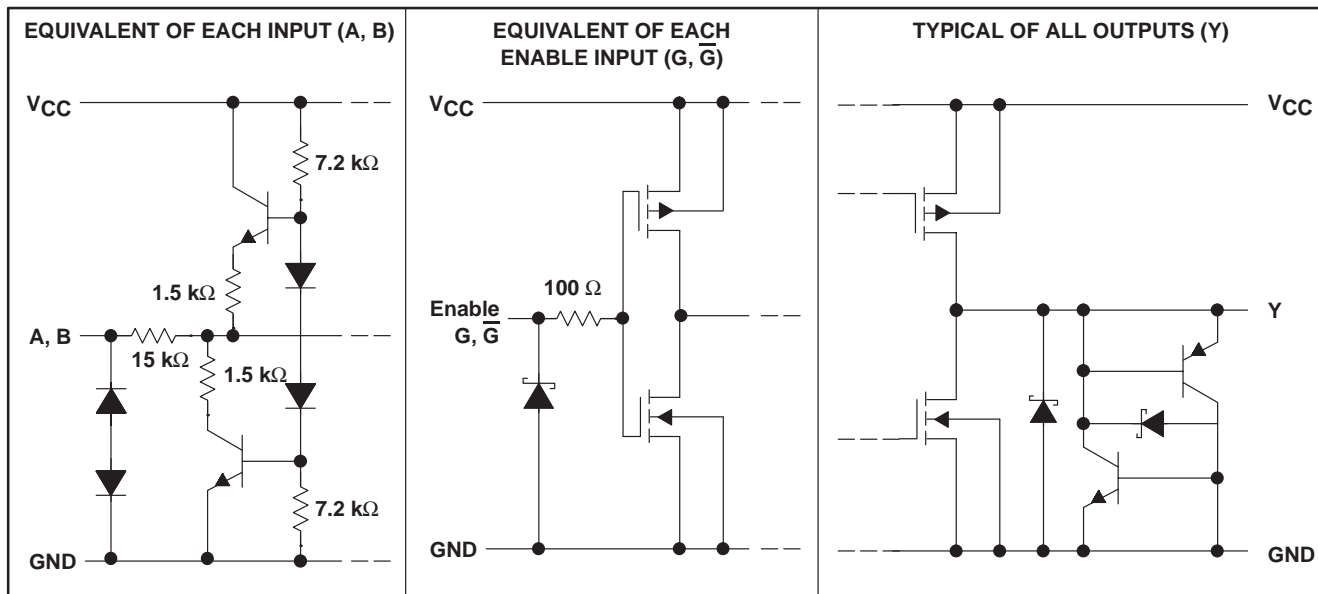

### absolute maximum ratings over operating free-air temperature range (unless otherwise noted)†

Supply voltage range, $V_{CC}$ (see Note 1)	–0.3 V to 6 V
Input voltage range, $V_I$ (A or B inputs)	–4 V to 8 V
Differential input voltage, $V_{ID}$ (see Note 2)	$\pm 12$ V
Enable input voltage range	–0.3 V to 6 V
Output voltage range, $V_O$	–0.3 V to 6 V
Maximum output current, $I_O$	$\pm 25$ mA
Package thermal impedance, $\theta_{JA}$ (see Note 3): D package	73°C/W
NS package	64°C/W
Lead temperature 1,6 mm (1/16 inch) from case for 10 seconds	260°C
Storage temperature range, $T_{stg}$	–65°C to 150°C

† Stresses beyond those listed under “absolute maximum ratings” may cause permanent damage to the device. These are stress ratings only, and functional operation of the device at these or any other conditions beyond those indicated under “recommended operating conditions” is not implied. Exposure to absolute-maximum-rated conditions for extended periods may affect device reliability.

- NOTES: 1. All voltage values are with respect to the GND terminal.  
 2. Differential input voltage is measured at the noninverting input with respect to the corresponding inverting input.  
 3. The package thermal impedance is calculated in accordance with JESD 51.

### recommended operating conditions

	MIN	NOM	MAX	UNIT
Supply voltage, $V_{CC}$	3	3.3	3.6	V
High-level input voltage, $V_{IH}(EN)$	2			V
Low-level input voltage, $V_{IL}(EN)$			0.8	V
Common-mode input voltage, $V_{IC}$	–0.3		5.5	V
Differential input voltage, $V_{ID}$			$\pm 5.8$	
High-level output current, $I_{OH}$			–5	mA
Low-level output current, $I_{OL}$			5	mA
Operating free-air temperature, $T_A$	AM26LV32C	0	70	°C
	AM26LV32I	–40	85	



# AM26LV32C, AM26LV32I

## LOW-VOLTAGE HIGH-SPEED QUADRUPLE DIFFERENTIAL LINE RECEIVER

SLLS202E – MAY 1995 – REVISED JUNE 2005

electrical characteristics over recommended supply-voltage and operating free-air temperature ranges (unless otherwise noted)

PARAMETER	TEST CONDITIONS	MIN	TYP†	MAX	UNIT
V <sub>IT+</sub>	Differential input high-threshold voltage			0.2	V
V <sub>IT-</sub>	Differential input low-threshold voltage	-0.2			V
V <sub>IK</sub>	Enable input clamp voltage	I <sub>I</sub> = -18 mA	-0.8	-1.5	V
V <sub>OH</sub>	High-level output voltage	V <sub>ID</sub> = 200 mV, I <sub>OH</sub> = -5 mA	2.4	3.2	V
V <sub>OL</sub>	Low-level output voltage	V <sub>ID</sub> = -200 mV, I <sub>OL</sub> = 5 mA	0.17	0.5	V
I <sub>OZ</sub>	High-impedance-state output current	V <sub>O</sub> = 0 to V <sub>CC</sub>		±50	μA
I <sub>IH(E)</sub>	High-level enable input current	V <sub>CC</sub> = 0 or 3 V, V <sub>I</sub> = 5.5 V		10	μA
I <sub>IL(E)</sub>	Low-level enable input current	V <sub>CC</sub> = 3.6 V, V <sub>I</sub> = 0 V		-10	
r <sub>I</sub>	Input resistance		7	12	kΩ
I <sub>I</sub>	Input current	V <sub>I</sub> = 5.5 V or -0.3 V, All other inputs GND		±700	μA
I <sub>CC</sub>	Supply current	V <sub>I(E)</sub> = V <sub>CC</sub> or GND, No load, line inputs open	8	17	mA
C <sub>pd</sub>	Power dissipation capacitance‡	One channel	150		pF

† All typical values are at V<sub>CC</sub> = 3.3 V and T<sub>A</sub> = 25°C.

‡ C<sub>pd</sub> determines the no-load dynamic current: I<sub>S</sub> = C<sub>pd</sub> × V<sub>CC</sub> × f + I<sub>CC</sub>.

### switching characteristics, V<sub>CC</sub> = 3.3 V, T<sub>A</sub> = 25°C

PARAMETER	TEST CONDITIONS	MIN	TYP	MAX	UNIT	
t <sub>PLH</sub>	Propagation delay time, low- to high-level output	See Figure 1	8	16	20	ns
t <sub>PHL</sub>	Propagation delay time, high- to low-level output		8	16	20	
t <sub>t</sub>	Transistion time (t <sub>r</sub> or t <sub>f</sub> )	See Figure 1	5		ns	
t <sub>PZH</sub>	Output-enable time to high level	See Figure 2	17	40	ns	
t <sub>PZL</sub>	Output-enable time to low level	See Figure 3	10	40	ns	
t <sub>PHZ</sub>	Output-disable time from high level	See Figure 2	20	40	ns	
t <sub>PLZ</sub>	Output-disable time from low level	See Figure 3	16	40	ns	
t <sub>sk(p)</sub> §	Pulse skew		4	6	ns	
t <sub>sk(o)</sub> ¶	Pulse skew		4	6	ns	
t <sub>sk(pp)</sub> #	Pulse skew (device to device)		6	9	ns	

§ t<sub>sk(p)</sub> is |t<sub>PLH</sub> - t<sub>PHL</sub>| of each channel of the same device.

¶ t<sub>sk(o)</sub> is the maximum difference in propagation delay times between any two channels of the same device switching in the same direction.

# t<sub>sk(pp)</sub> is the maximum difference in propagation delay times between any two channels of any two devices switching in the same direction.



# AM26LV32C, AM26LV32I

## LOW-VOLTAGE HIGH-SPEED QUADRUPLE DIFFERENTIAL LINE RECEIVER

SLLS202E – MAY 1995 – REVISED JUNE 2005

### PARAMETER MEASUREMENT INFORMATION

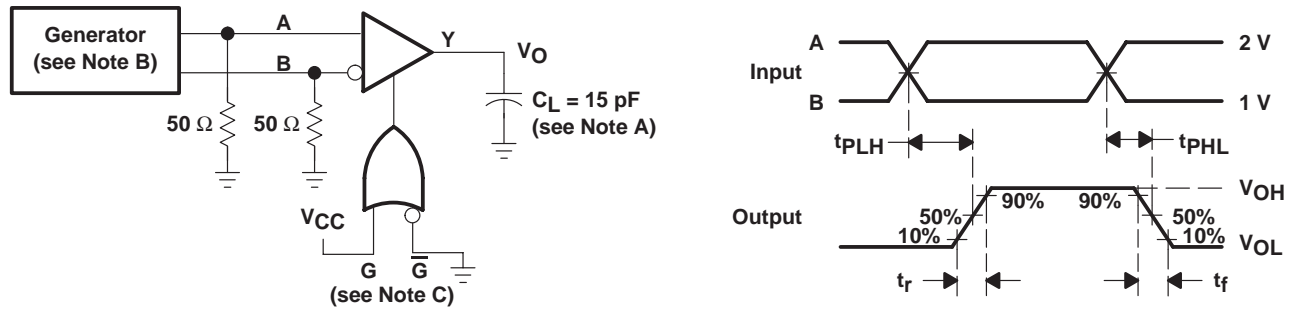

- NOTES: A.  $C_L$  includes probe and jig capacitance.  
 B. The input pulse is supplied by a generator having the following characteristics:  $Z_O = 50 \Omega$ , PRR = 10 MHz,  $t_r$  and  $t_f$  (10% to 90%)  $\leq 2$  ns, 50% duty cycle.  
 C. To test the active-low enable  $\bar{G}$ , ground G and apply an inverted waveform  $\bar{G}$ .

**Figure 1.  $t_{PLH}$  and  $t_{PHL}$  Test Circuit and Voltage Waveforms**

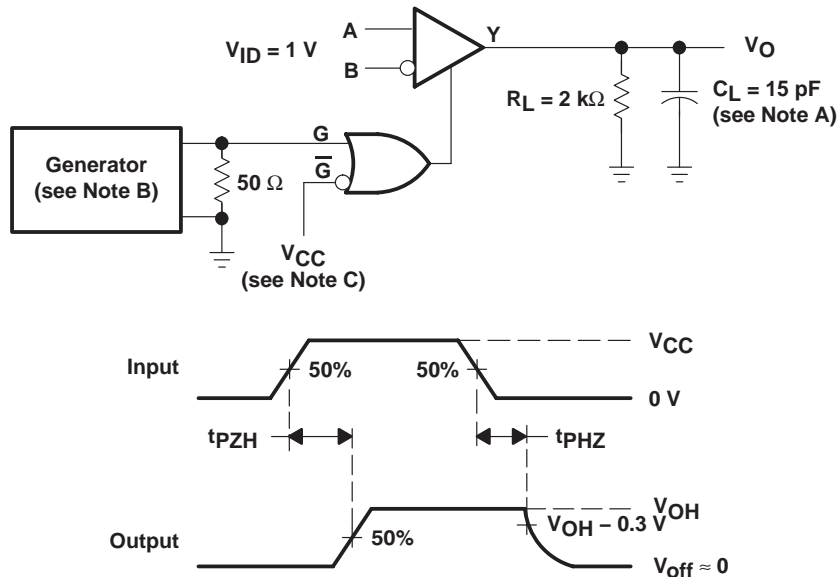

- NOTES: A.  $C_L$  includes probe and jig capacitance.  
 B. The input pulse is supplied by a generator having the following characteristics:  $Z_O = 50 \Omega$ , PRR = 10 MHz,  $t_r$  and  $t_f$  (10% to 90%)  $\leq 2$  ns, 50% duty cycle.  
 C. To test the active-low enable  $\bar{G}$ , ground G and apply an inverted waveform  $\bar{G}$ .

**Figure 2.  $t_{PZH}$  and  $t_{PHZ}$  Test Circuit and Voltage Waveforms**

# AM26LV32C, AM26LV32I LOW-VOLTAGE HIGH-SPEED QUADRUPLE DIFFERENTIAL LINE RECEIVER

SLLS202E – MAY 1995 – REVISED JUNE 2005

## PARAMETER MEASUREMENT INFORMATION

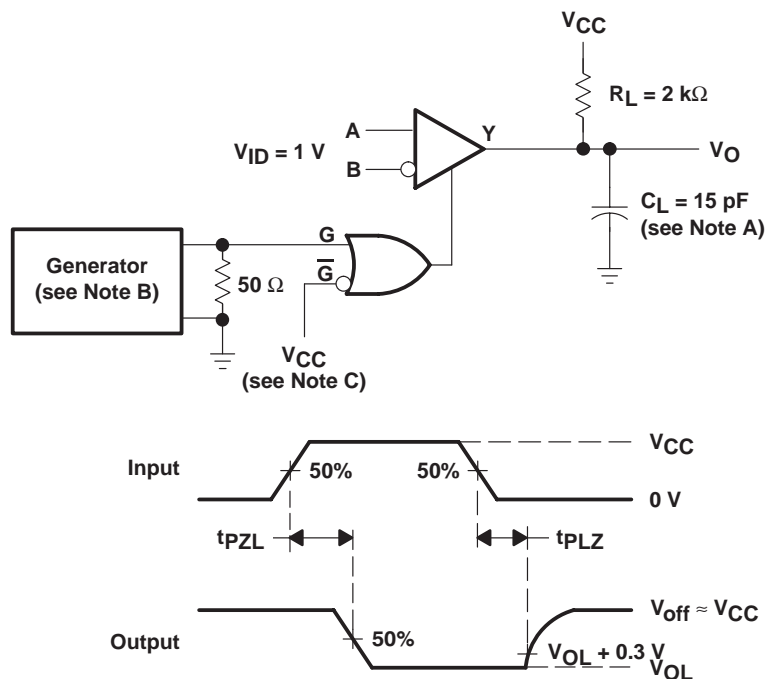

- NOTES: A.  $C_L$  includes probe and jig capacitance.  
 B. The input pulse is supplied by a generator having the following characteristics:  $Z_O = 50\ \Omega$ , PRR = 10 MHz,  $t_r$  and  $t_f$  (10% to 90%)  $\leq 2\text{ ns}$ , 50% duty cycle.  
 C. To test the active-low enable  $\bar{G}$ , ground G and apply an inverted waveform  $\bar{G}$ .

Figure 3.  $t_{pZL}$  and  $t_{pLZ}$  Test Circuit and Voltage Waveforms

---

## APPLICATION INFORMATION

### fail-safe conditions

The AM26LV32 quadruple differential line receiver is designed to function properly when appropriately connected to active drivers. Applications do not always have ideal situations where all bits are being used, the receiver inputs are never left floating, and fault conditions don't exist. In actuality, most applications have the capability to either place the drivers in a high-impedance mode or power down the drivers altogether, and cables may be purposely (or inadvertently) disconnected, both of which lead to floating receiver inputs. Furthermore, even though measures are taken to avoid fault conditions like a short between the differential signals, this does occur. The AM26LV32 has an internal fail-safe circuitry which prevents the device from putting an unknown voltage signal at the receiver outputs. In the following three cases, a high-state is produced at the respective output:

1. Open fail-safe – Unused input pins are left open. Do not tie unused pins to ground or any other voltage. Internal circuitry places the output in the high state.
2. 100-ohm terminated fail-safe – Disconnected cables, drivers in high-impedance state, or powered-down drivers will not cause the AM26LV32 to malfunction. The outputs will remain in a high state under these conditions. When the drivers are either turned-off or placed into the high-impedance state, the receiver input may still be able to pick up noise due to the cable acting as an antenna. To avoid having a large differential voltage being generated, the use of twisted-pair cable will induce the noise as a common-mode signal and will be rejected.
3. Shorted fail-safe – Fault conditions that short the differential input pairs together will not cause incorrect data at the outputs. A differential voltage ( $V_{ID}$ ) of 0 V will force a high state at the outputs. Shorted fail-safe, however, is not supported across the recommended common-mode input voltage ( $V_{IC}$ ) range. An unwanted state can be induced to all outputs when an input is shorted and is biased with a voltage between  $-0.3$  V and 5.5 V. The shorted fail-safe circuitry will function properly when an input is shorted, but with no external common-mode voltage applied.

### fail-safe precautions

The internal fail-safe circuitry was designed such that the input common-mode ( $V_{IC}$ ) and differential ( $V_{ID}$ ) voltages must be observed. In order to ensure the outputs of unused or inactive receivers remain in a high state when the inputs are open-circuited, shorted, or terminated, extra precaution must be taken on the active signal. In applications where the drivers are placed in a high-impedance mode or are powered-down, it is recommended that for 1, 2, or 3 active receiver inputs, the low-level input voltage ( $V_{IL}$ ) should be greater than 0.4 V. As in all data transmission applications, it is necessary to provide a return ground path between the two remote grounds (driver and receiver ground references) to avoid ground differences. Table 1 and Figures 4 through 7 are examples of active input voltages with their respective waveforms and the effect each have on unused or inactive outputs. Note that the active receivers behave as expected, regardless of the input levels.

# AM26LV32C, AM26LV32I

## LOW-VOLTAGE HIGH-SPEED QUADRUPLE DIFFERENTIAL LINE RECEIVER

SLLS202E – MAY 1995 – REVISED JUNE 2005

### APPLICATION INFORMATION

Table 1. Active Receiver Inputs vs Outputs

1, 2, OR 3 ACTIVE INPUTS			SEE FIGURE	1, 2, OR 3 ACTIVE OUTPUTS	3, 2, OR 1 UNUSED OR INACTIVE OUTPUTS
$V_{IL}^\dagger$	$V_{ID}$	$V_{IC}^\dagger$			
900 mV	200 mV	1 V	4	Known state	High state
-100 mV	200 mV	0 V	5	Known state	?
600 mV	800 mV	1 V	6	Known state	High state
0	800 mV	400 mV	7	Known state	?

<sup>†</sup> Measured with respect to ground.

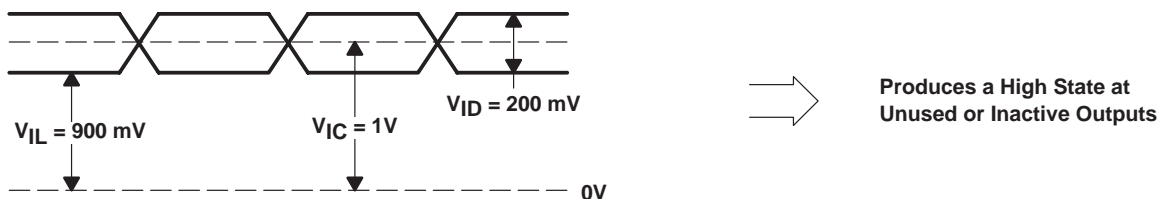

Figure 4. Waveform One

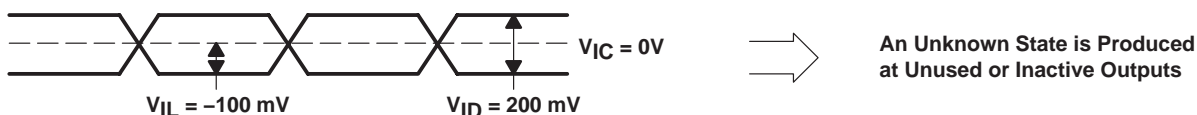

Figure 5. Waveform Two

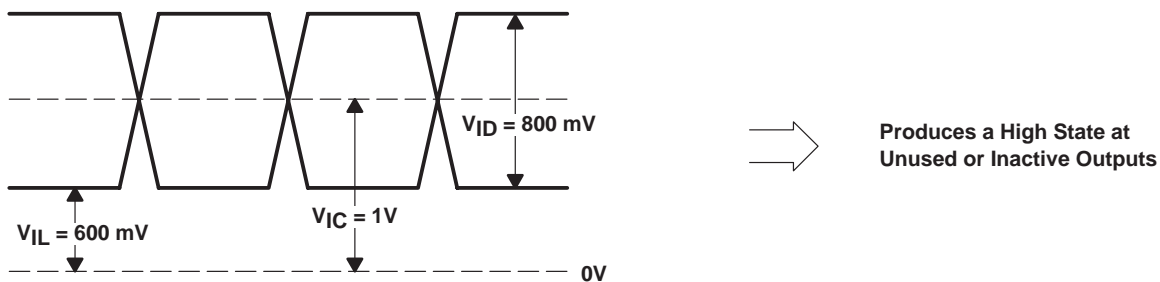

Figure 6. Waveform Three

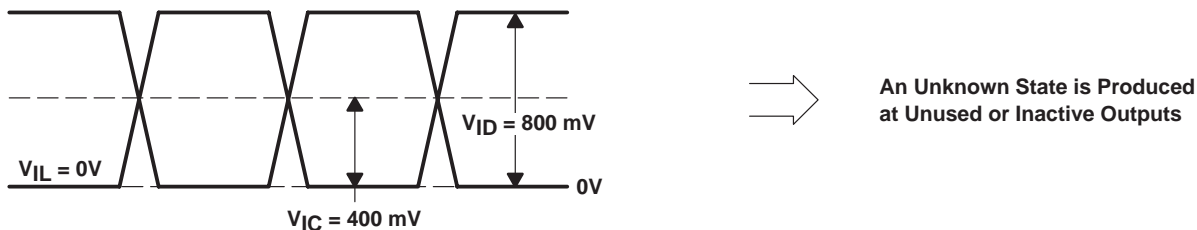

Figure 7. Waveform Four





### APPLICATION INFORMATION

In most applications, it is not customary to have a common-mode input close to ground and to have a differential voltage larger than 2 V. Since the common-mode input voltage is typically around 1.5 V, a 2-V  $V_{ID}$  would result in a  $V_{IL}$  of 0.5 V, thus satisfying the recommended  $V_{IL}$  level of greater than 0.4 V.

Figure 8 plots seven different input threshold curves from a variety of production lots and shows how the fail-safe circuitry behaves with the input common-mode voltage levels. These input threshold curves are representative samples of production devices. The curves specifically illustrate a typical range of input threshold variation. The AM26LV32 is specified with  $\pm 200$  mV of input sensitivity to account for the variance in input threshold. Each data point represents the input's ability to produce a known state at the output for a given  $V_{IC}$  and  $V_{ID}$ . Applying a differential voltage at or above a certain point on a curve would produce a known state at the output. Applying a differential voltage less than a certain point on a curve would activate the fail-safe circuit and the output would be in a high state. For example, inspecting the top input threshold curve reveals that for a  $V_{IC} = 1.6$  V,  $V_{ID}$  yields around 87 mV. Applying 90 mV of differential voltage to this particular production lot generates a known receiver output voltage. Applying a  $V_{ID}$  of 80 mV activates the input fail-safe circuitry and the receiver output is placed in the high state. Texas Instruments specifies the input threshold at  $\pm 200$  mV, since normal process variations affect this parameter. Note that at common-mode input voltages around 0.2 V, the input differential voltages are low compared to their respective data points. This phenomenon points to the fact that the inputs are very sensitive to small differential voltages around 0.2 V  $V_{IC}$ . It is recommended that  $V_{IC}$  levels be kept greater than 0.5 V to avoid this increased sensitivity at  $V_{IC} \approx 0.2$  V. In most applications, since  $V_{IC}$  typically is 1.5 V, the fail-safe circuitry functions properly to provide a high state at the receiver output.

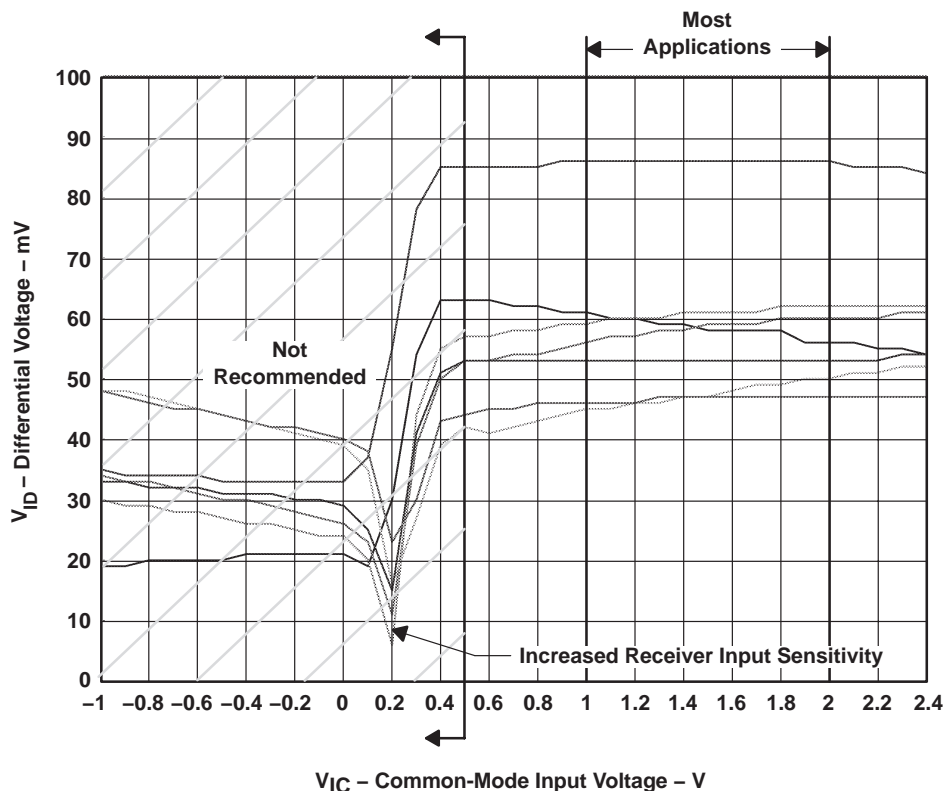

**Figure 8.  $V_{IC}$  Versus  $V_{ID}$  Receiver Sensitivity Levels**

# AM26LV32C, AM26LV32I LOW-VOLTAGE HIGH-SPEED QUADRUPLE DIFFERENTIAL LINE RECEIVER

SLLS202E – MAY 1995 – REVISED JUNE 2005

## APPLICATION INFORMATION

Figure 9 represents a typical application where two receivers are not used. In this case, there is no need to worry about the output voltages of the unused receivers since they are not connected in the system architecture.

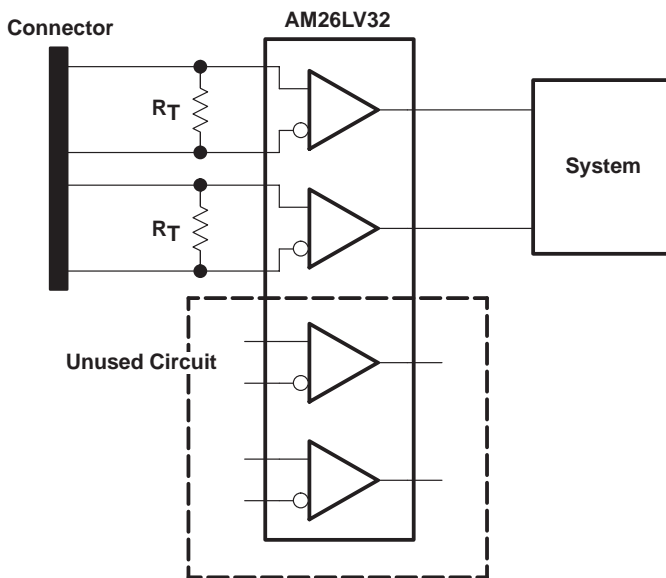

Figure 9. Typical Application with Unused Receivers

Figure 10 shows a common application where one or more drivers are either disabled or powered down. To ensure the inactive receiver outputs are in a high state, the active receiver inputs must have  $V_{IL} > 0.4\text{ V}$  and  $V_{IC} > 0.5\text{ V}$ .

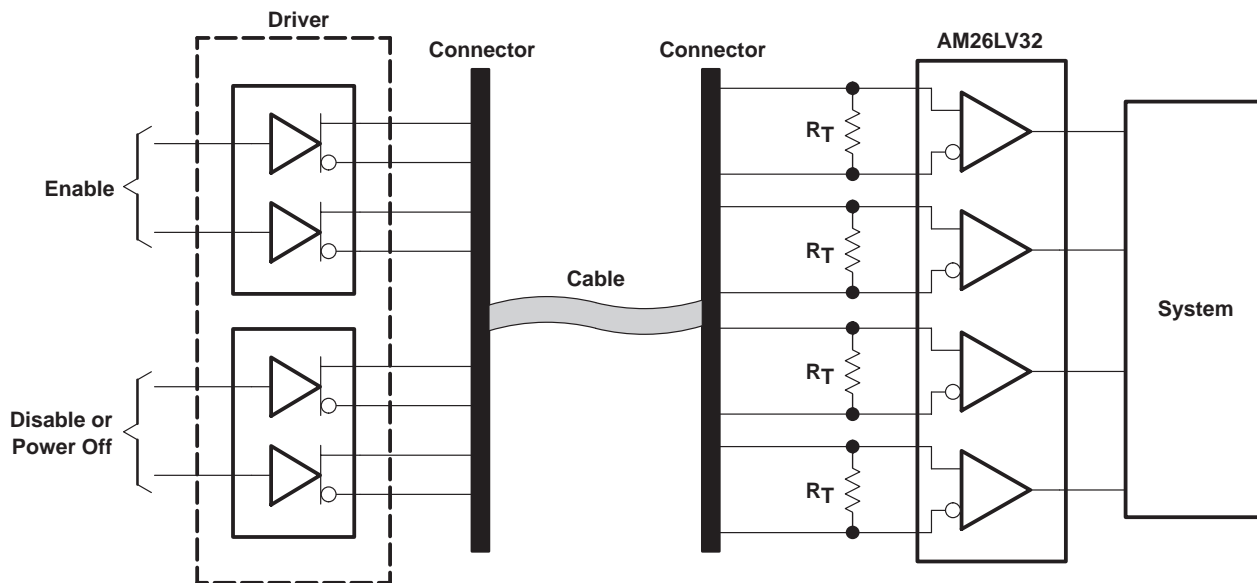
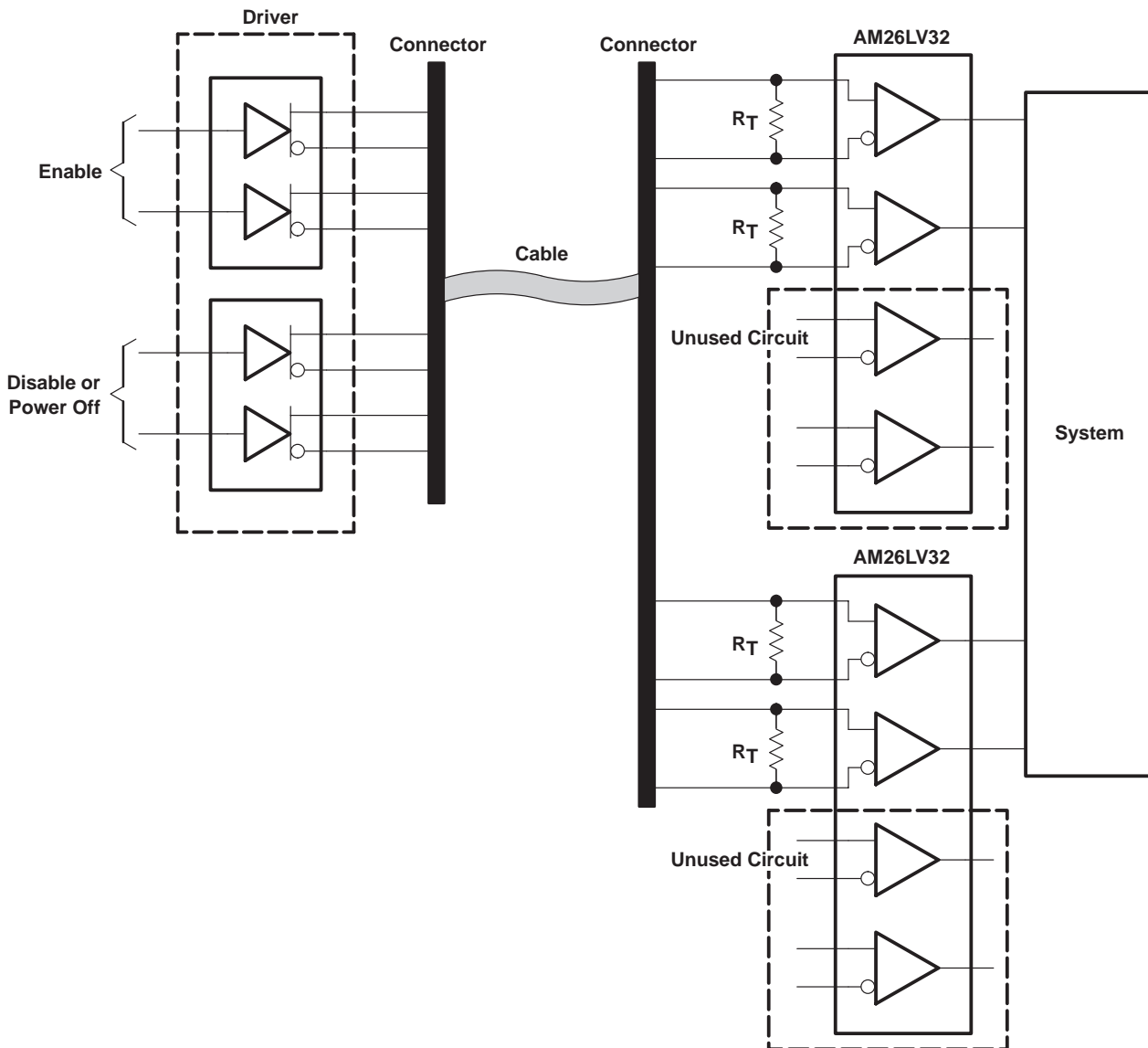

Figure 10. Typical Application Where Two or More Drivers are Disabled

**APPLICATION INFORMATION**

Figure 11 is an alternative application design to replace the application in Figure 10. This design uses two AM26LV32 devices, instead of one. However, this design does not require the input levels be monitored to ensure the outputs are in the correct state, only that they comply to the RS-232 standard.



**Figure 11. Alternative Solution for Figure 10**

# AM26LV32C, AM26LV32I LOW-VOLTAGE HIGH-SPEED QUADRUPLE DIFFERENTIAL LINE RECEIVER

SLLS202E – MAY 1995 – REVISED JUNE 2005

## APPLICATION INFORMATION

Figures 12 and 13 show typical applications where a disconnected cable occurs. Figure 12 illustrates a typical application where a cable is disconnected. Similar to Figure 10, the active input levels must be monitored to make sure the inactive receiver outputs are in a high state. An alternative solution is shown in Figure 13.

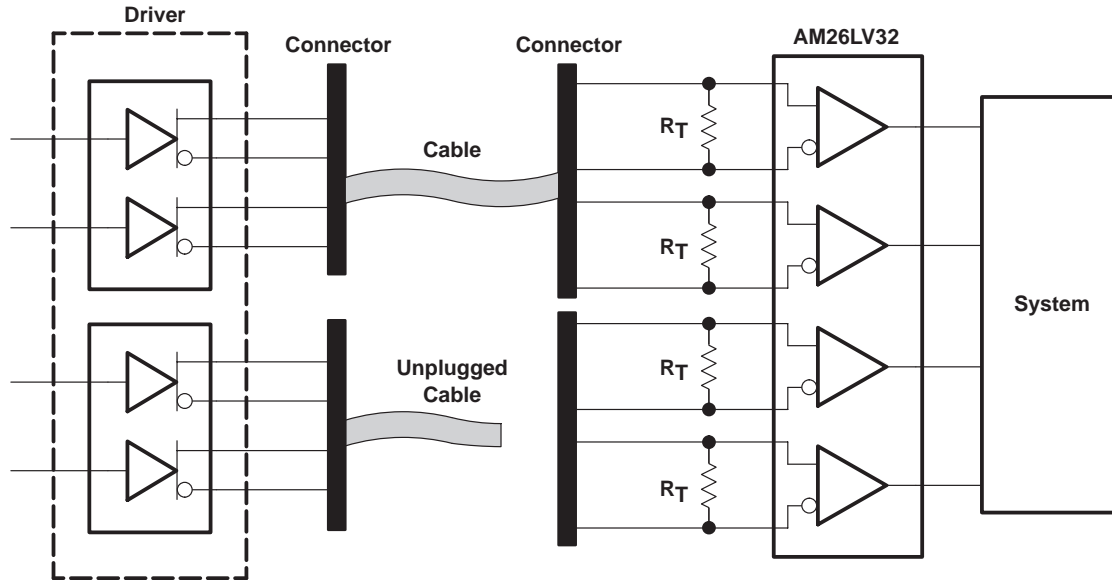

Figure 12. Typical Application Where Two or More Drivers are Disconnected

# AM26LV32C, AM26LV32I LOW-VOLTAGE HIGH-SPEED QUADRUPLE DIFFERENTIAL LINE RECEIVER

SLLS202E – MAY 1995 – REVISED JUNE 2005

## APPLICATION INFORMATION

Figure 13 is an alternative solution so the receiver inputs do not have to be monitored. This solution also requires the use of two AM26LV32 devices, instead of one.

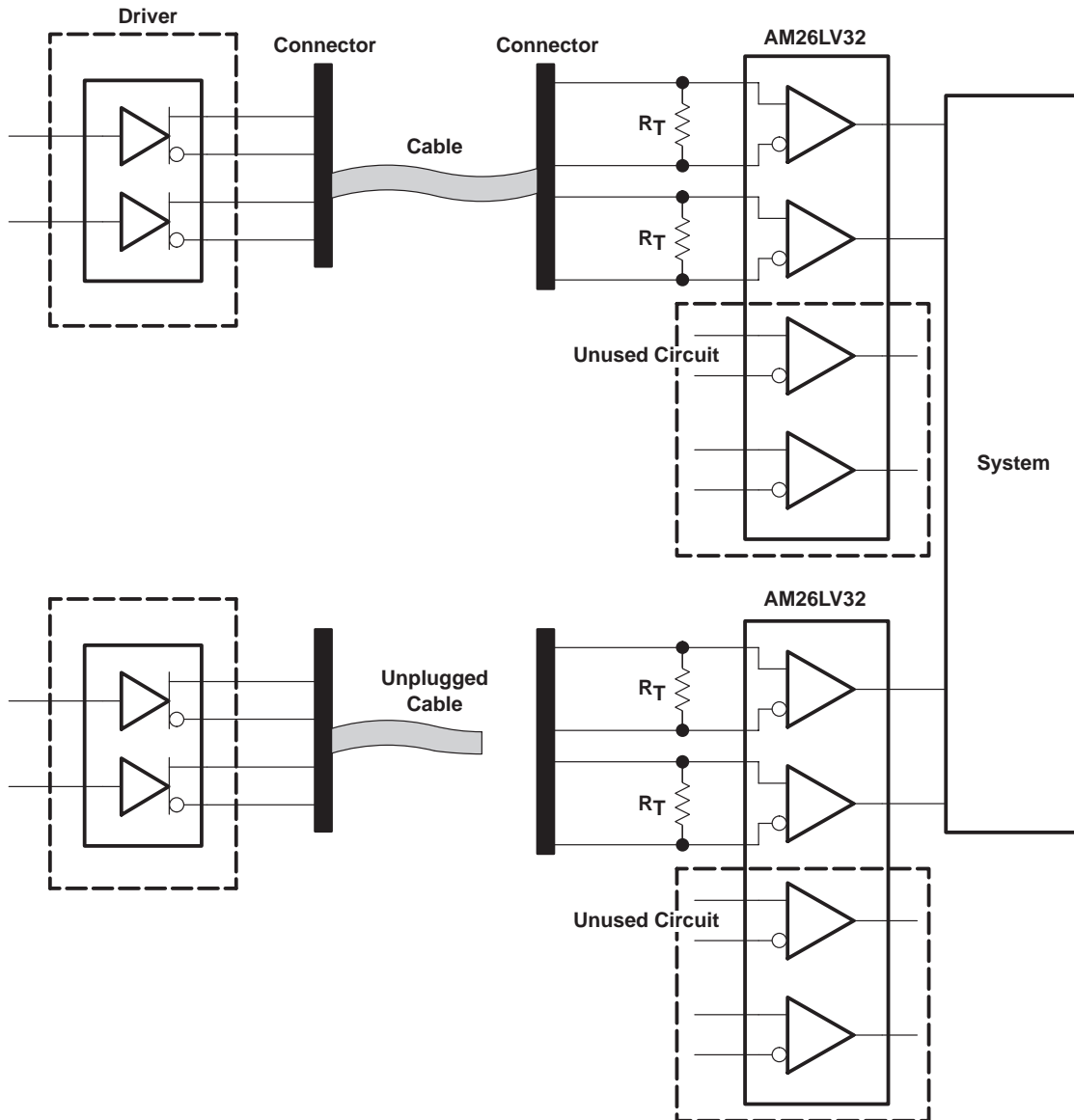

Figure 13. Alternative Solution to Figure 12

# AM26LV32C, AM26LV32I

## LOW-VOLTAGE HIGH-SPEED QUADRUPLE DIFFERENTIAL LINE RECEIVER

SLLS202E – MAY 1995 – REVISED JUNE 2005

---

### APPLICATION INFORMATION

When designing a system using the AM26LV32, the device provides a robust solution where fail-safe and fault conditions are of concern. The RS-422-like inputs accept common-mode input levels from  $-0.3\text{ V}$  to  $5.5\text{ V}$  with a specified sensitivity of  $\pm 200\text{ mV}$ . As previously shown, care must be taken with active input levels since they can affect the outputs of unused or inactive bits. However, most applications meet or exceed the requirements to allow the device to perform properly.



POST OFFICE BOX 655303 • DALLAS, TEXAS 75265

**PACKAGING INFORMATION**

Orderable Device	Status (1)	Package Type	Package Drawing	Pins	Package Qty	Eco Plan (2)	Lead/Ball Finish	MSL Peak Temp (3)	Op Temp (°C)	Top-Side Markings (4)	Samples
AM26LV32CD	ACTIVE	SOIC	D	16	40	Green (RoHS & no Sb/Br)	CU NIPDAU	Level-1-260C-UNLIM	0 to 70	AM26LV32C	<a href="#">Samples</a>
AM26LV32CDE4	ACTIVE	SOIC	D	16	40	Green (RoHS & no Sb/Br)	CU NIPDAU	Level-1-260C-UNLIM	0 to 70	AM26LV32C	<a href="#">Samples</a>
AM26LV32CDG4	ACTIVE	SOIC	D	16	40	Green (RoHS & no Sb/Br)	CU NIPDAU	Level-1-260C-UNLIM	0 to 70	AM26LV32C	<a href="#">Samples</a>
AM26LV32CDR	ACTIVE	SOIC	D	16	2500	Green (RoHS & no Sb/Br)	CU NIPDAU	Level-1-260C-UNLIM	0 to 70	AM26LV32C	<a href="#">Samples</a>
AM26LV32CDRE4	ACTIVE	SOIC	D	16	2500	Green (RoHS & no Sb/Br)	CU NIPDAU	Level-1-260C-UNLIM	0 to 70	AM26LV32C	<a href="#">Samples</a>
AM26LV32CDRG4	ACTIVE	SOIC	D	16	2500	Green (RoHS & no Sb/Br)	CU NIPDAU	Level-1-260C-UNLIM	0 to 70	AM26LV32C	<a href="#">Samples</a>
AM26LV32CNSLE	OBSOLETE	SO	NS	16		TBD	Call TI	Call TI	0 to 70		
AM26LV32CNSR	ACTIVE	SO	NS	16	2000	Green (RoHS & no Sb/Br)	CU NIPDAU	Level-1-260C-UNLIM	0 to 70	26LV32	<a href="#">Samples</a>
AM26LV32CNSRE4	ACTIVE	SO	NS	16	2000	Green (RoHS & no Sb/Br)	CU NIPDAU	Level-1-260C-UNLIM	0 to 70	26LV32	<a href="#">Samples</a>
AM26LV32CNSRG4	ACTIVE	SO	NS	16	2000	Green (RoHS & no Sb/Br)	CU NIPDAU	Level-1-260C-UNLIM	0 to 70	26LV32	<a href="#">Samples</a>
AM26LV32ID	ACTIVE	SOIC	D	16	40	Green (RoHS & no Sb/Br)	CU NIPDAU	Level-1-260C-UNLIM	-40 to 85	AM26LV32I	<a href="#">Samples</a>
AM26LV32IDE4	ACTIVE	SOIC	D	16	40	Green (RoHS & no Sb/Br)	CU NIPDAU	Level-1-260C-UNLIM	-40 to 85	AM26LV32I	<a href="#">Samples</a>
AM26LV32IDG4	ACTIVE	SOIC	D	16	40	Green (RoHS & no Sb/Br)	CU NIPDAU	Level-1-260C-UNLIM	-40 to 85	AM26LV32I	<a href="#">Samples</a>
AM26LV32IDR	ACTIVE	SOIC	D	16	2500	Green (RoHS & no Sb/Br)	CU NIPDAU	Level-1-260C-UNLIM	-40 to 85	AM26LV32I	<a href="#">Samples</a>
AM26LV32IDRE4	ACTIVE	SOIC	D	16	2500	Green (RoHS & no Sb/Br)	CU NIPDAU	Level-1-260C-UNLIM	-40 to 85	AM26LV32I	<a href="#">Samples</a>
AM26LV32IDRG4	ACTIVE	SOIC	D	16	2500	Green (RoHS & no Sb/Br)	CU NIPDAU	Level-1-260C-UNLIM	-40 to 85	AM26LV32I	<a href="#">Samples</a>
AM26LV32INS	ACTIVE	SO	NS	16	50	Green (RoHS & no Sb/Br)	CU NIPDAU	Level-1-260C-UNLIM	-40 to 85	26LV32I	<a href="#">Samples</a>

Orderable Device	Status (1)	Package Type	Package Drawing	Pins	Package Qty	Eco Plan (2)	Lead/Ball Finish	MSL Peak Temp (3)	Op Temp (°C)	Top-Side Markings (4)	Samples
AM26LV32INSE4	ACTIVE	SO	NS	16	50	Green (RoHS & no Sb/Br)	CU NIPDAU	Level-1-260C-UNLIM	-40 to 85	26LV32I	<a href="#">Samples</a>
AM26LV32INSG4	ACTIVE	SO	NS	16	50	Green (RoHS & no Sb/Br)	CU NIPDAU	Level-1-260C-UNLIM	-40 to 85	26LV32I	<a href="#">Samples</a>
AM26LV32INSR	ACTIVE	SO	NS	16	2000	Green (RoHS & no Sb/Br)	CU NIPDAU	Level-1-260C-UNLIM	-40 to 85	26LV32I	<a href="#">Samples</a>
AM26LV32INSRE4	ACTIVE	SO	NS	16	2000	Green (RoHS & no Sb/Br)	CU NIPDAU	Level-1-260C-UNLIM	-40 to 85	26LV32I	<a href="#">Samples</a>
AM26LV32INSRG4	ACTIVE	SO	NS	16	2000	Green (RoHS & no Sb/Br)	CU NIPDAU	Level-1-260C-UNLIM	-40 to 85	26LV32I	<a href="#">Samples</a>

(1) The marketing status values are defined as follows:

**ACTIVE:** Product device recommended for new designs.

**LIFEBUY:** TI has announced that the device will be discontinued, and a lifetime-buy period is in effect.

**NRND:** Not recommended for new designs. Device is in production to support existing customers, but TI does not recommend using this part in a new design.

**PREVIEW:** Device has been announced but is not in production. Samples may or may not be available.

**OBSOLETE:** TI has discontinued the production of the device.

(2) Eco Plan - The planned eco-friendly classification: Pb-Free (RoHS), Pb-Free (RoHS Exempt), or Green (RoHS & no Sb/Br) - please check <http://www.ti.com/productcontent> for the latest availability information and additional product content details.

**TBD:** The Pb-Free/Green conversion plan has not been defined.

**Pb-Free (RoHS):** TI's terms "Lead-Free" or "Pb-Free" mean semiconductor products that are compatible with the current RoHS requirements for all 6 substances, including the requirement that lead not exceed 0.1% by weight in homogeneous materials. Where designed to be soldered at high temperatures, TI Pb-Free products are suitable for use in specified lead-free processes.

**Pb-Free (RoHS Exempt):** This component has a RoHS exemption for either 1) lead-based flip-chip solder bumps used between the die and package, or 2) lead-based die adhesive used between the die and leadframe. The component is otherwise considered Pb-Free (RoHS compatible) as defined above.

**Green (RoHS & no Sb/Br):** TI defines "Green" to mean Pb-Free (RoHS compatible), and free of Bromine (Br) and Antimony (Sb) based flame retardants (Br or Sb do not exceed 0.1% by weight in homogeneous material)

(3) MSL, Peak Temp. -- The Moisture Sensitivity Level rating according to the JEDEC industry standard classifications, and peak solder temperature.

(4) Only one of markings shown within the brackets will appear on the physical device.

**Important Information and Disclaimer:** The information provided on this page represents TI's knowledge and belief as of the date that it is provided. TI bases its knowledge and belief on information provided by third parties, and makes no representation or warranty as to the accuracy of such information. Efforts are underway to better integrate information from third parties. TI has taken and continues to take reasonable steps to provide representative and accurate information but may not have conducted destructive testing or chemical analysis on incoming materials and chemicals. TI and TI suppliers consider certain information to be proprietary, and thus CAS numbers and other limited information may not be available for release.

In no event shall TI's liability arising out of such information exceed the total purchase price of the TI part(s) at issue in this document sold by TI to Customer on an annual basis.





**TAPE AND REEL INFORMATION**

**QUADRANT ASSIGNMENTS FOR PIN 1 ORIENTATION IN TAPE**

\*All dimensions are nominal

Device	Package Type	Package Drawing	Pins	SPQ	Reel Diameter (mm)	Reel Width W1 (mm)	A0 (mm)	B0 (mm)	K0 (mm)	P1 (mm)	W (mm)	Pin1 Quadrant
AM26LV32CDR	SOIC	D	16	2500	330.0	16.4	6.5	10.3	2.1	8.0	16.0	Q1
AM26LV32CDR	SOIC	D	16	2500	330.0	16.4	6.5	10.3	2.1	8.0	16.0	Q1
AM26LV32CNSR	SO	NS	16	2000	330.0	16.4	8.2	10.5	2.5	12.0	16.0	Q1
AM26LV32IDR	SOIC	D	16	2500	330.0	16.4	6.5	10.3	2.1	8.0	16.0	Q1
AM26LV32INSR	SO	NS	16	2000	330.0	16.4	8.2	10.5	2.5	12.0	16.0	Q1

**TAPE AND REEL BOX DIMENSIONS**

\*All dimensions are nominal

Device	Package Type	Package Drawing	Pins	SPQ	Length (mm)	Width (mm)	Height (mm)
AM26LV32CDR	SOIC	D	16	2500	333.2	345.9	28.6
AM26LV32CDR	SOIC	D	16	2500	367.0	367.0	38.0
AM26LV32CNSR	SO	NS	16	2000	367.0	367.0	38.0
AM26LV32IDR	SOIC	D	16	2500	333.2	345.9	28.6
AM26LV32INSR	SO	NS	16	2000	367.0	367.0	38.0

D (R-PDSO-G16)

PLASTIC SMALL OUTLINE



- NOTES:
- A. All linear dimensions are in inches (millimeters).
  - B. This drawing is subject to change without notice.
  - C. Body length does not include mold flash, protrusions, or gate burrs. Mold flash, protrusions, or gate burrs shall not exceed 0.006 (0,15) each side.
  - D. Body width does not include interlead flash. Interlead flash shall not exceed 0.017 (0,43) each side.
  - E. Reference JEDEC MS-012 variation AC.

D (R-PDSO-G16)

PLASTIC SMALL OUTLINE



- NOTES:
- All linear dimensions are in millimeters.
  - This drawing is subject to change without notice.
  - Publication IPC-7351 is recommended for alternate designs.
  - Laser cutting apertures with trapezoidal walls and also rounding corners will offer better paste release. Customers should contact their board assembly site for stencil design recommendations. Refer to IPC-7525 for other stencil recommendations.
  - Customers should contact their board fabrication site for solder mask tolerances between and around signal pads.

# MECHANICAL DATA

NS (R-PDSO-G\*\*)

PLASTIC SMALL-OUTLINE PACKAGE

14-PINS SHOWN



- NOTES:
- A. All linear dimensions are in millimeters.
  - B. This drawing is subject to change without notice.
  - C. Body dimensions do not include mold flash or protrusion, not to exceed 0,15.

## IMPORTANT NOTICE

Texas Instruments Incorporated and its subsidiaries (TI) reserve the right to make corrections, enhancements, improvements and other changes to its semiconductor products and services per JESD46, latest issue, and to discontinue any product or service per JESD48, latest issue. Buyers should obtain the latest relevant information before placing orders and should verify that such information is current and complete. All semiconductor products (also referred to herein as "components") are sold subject to TI's terms and conditions of sale supplied at the time of order acknowledgment.

TI warrants performance of its components to the specifications applicable at the time of sale, in accordance with the warranty in TI's terms and conditions of sale of semiconductor products. Testing and other quality control techniques are used to the extent TI deems necessary to support this warranty. Except where mandated by applicable law, testing of all parameters of each component is not necessarily performed.

TI assumes no liability for applications assistance or the design of Buyers' products. Buyers are responsible for their products and applications using TI components. To minimize the risks associated with Buyers' products and applications, Buyers should provide adequate design and operating safeguards.

TI does not warrant or represent that any license, either express or implied, is granted under any patent right, copyright, mask work right, or other intellectual property right relating to any combination, machine, or process in which TI components or services are used. Information published by TI regarding third-party products or services does not constitute a license to use such products or services or a warranty or endorsement thereof. Use of such information may require a license from a third party under the patents or other intellectual property of the third party, or a license from TI under the patents or other intellectual property of TI.

Reproduction of significant portions of TI information in TI data books or data sheets is permissible only if reproduction is without alteration and is accompanied by all associated warranties, conditions, limitations, and notices. TI is not responsible or liable for such altered documentation. Information of third parties may be subject to additional restrictions.

Resale of TI components or services with statements different from or beyond the parameters stated by TI for that component or service voids all express and any implied warranties for the associated TI component or service and is an unfair and deceptive business practice. TI is not responsible or liable for any such statements.

Buyer acknowledges and agrees that it is solely responsible for compliance with all legal, regulatory and safety-related requirements concerning its products, and any use of TI components in its applications, notwithstanding any applications-related information or support that may be provided by TI. Buyer represents and agrees that it has all the necessary expertise to create and implement safeguards which anticipate dangerous consequences of failures, monitor failures and their consequences, lessen the likelihood of failures that might cause harm and take appropriate remedial actions. Buyer will fully indemnify TI and its representatives against any damages arising out of the use of any TI components in safety-critical applications.

In some cases, TI components may be promoted specifically to facilitate safety-related applications. With such components, TI's goal is to help enable customers to design and create their own end-product solutions that meet applicable functional safety standards and requirements. Nonetheless, such components are subject to these terms.

No TI components are authorized for use in FDA Class III (or similar life-critical medical equipment) unless authorized officers of the parties have executed a special agreement specifically governing such use.

Only those TI components which TI has specifically designated as military grade or "enhanced plastic" are designed and intended for use in military/aerospace applications or environments. Buyer acknowledges and agrees that any military or aerospace use of TI components which have *not* been so designated is solely at the Buyer's risk, and that Buyer is solely responsible for compliance with all legal and regulatory requirements in connection with such use.

TI has specifically designated certain components as meeting ISO/TS16949 requirements, mainly for automotive use. In any case of use of non-designated products, TI will not be responsible for any failure to meet ISO/TS16949.

### Products

Audio	<a href="http://www.ti.com/audio">www.ti.com/audio</a>
Amplifiers	<a href="http://amplifier.ti.com">amplifier.ti.com</a>
Data Converters	<a href="http://dataconverter.ti.com">dataconverter.ti.com</a>
DLP® Products	<a href="http://www.dlp.com">www.dlp.com</a>
DSP	<a href="http://dsp.ti.com">dsp.ti.com</a>
Clocks and Timers	<a href="http://www.ti.com/clocks">www.ti.com/clocks</a>
Interface	<a href="http://interface.ti.com">interface.ti.com</a>
Logic	<a href="http://logic.ti.com">logic.ti.com</a>
Power Mgmt	<a href="http://power.ti.com">power.ti.com</a>
Microcontrollers	<a href="http://microcontroller.ti.com">microcontroller.ti.com</a>
RFID	<a href="http://www.ti-rfid.com">www.ti-rfid.com</a>
OMAP Applications Processors	<a href="http://www.ti.com/omap">www.ti.com/omap</a>
Wireless Connectivity	<a href="http://www.ti.com/wirelessconnectivity">www.ti.com/wirelessconnectivity</a>

### Applications

Automotive and Transportation	<a href="http://www.ti.com/automotive">www.ti.com/automotive</a>
Communications and Telecom	<a href="http://www.ti.com/communications">www.ti.com/communications</a>
Computers and Peripherals	<a href="http://www.ti.com/computers">www.ti.com/computers</a>
Consumer Electronics	<a href="http://www.ti.com/consumer-apps">www.ti.com/consumer-apps</a>
Energy and Lighting	<a href="http://www.ti.com/energy">www.ti.com/energy</a>
Industrial	<a href="http://www.ti.com/industrial">www.ti.com/industrial</a>
Medical	<a href="http://www.ti.com/medical">www.ti.com/medical</a>
Security	<a href="http://www.ti.com/security">www.ti.com/security</a>
Space, Avionics and Defense	<a href="http://www.ti.com/space-avionics-defense">www.ti.com/space-avionics-defense</a>
Video and Imaging	<a href="http://www.ti.com/video">www.ti.com/video</a>

### TI E2E Community

[e2e.ti.com](http://e2e.ti.com)