

# AN8377N

## 3-channel Linear Driver

### ■ Overview

The AN8377N is an IC which incorporates 3 circuits of BTL drivers for driving various DC motors such as actuators (focus, tracking, traverse), spindles, and loading of the CD players, and the +5V low drop type power supply.

### ■ Features

- Operating supply voltage range ;  $V_{CC}=5.5V$  to  $18V$
- Built-in 3 circuits of voltage BTL drivers  
(maximum drive current :  $500mA$ )
- Stable circuit operation against supply voltage change and temperature change due to the built-in stabilized power supply
- Built-in +5V low drop power supply (external PNP power transistor)
- Built-in reset circuit (reset voltage :  $4.82V$ )
- Built-in thermal protective circuit (operating temperature :  $159$  ; typ.)
- Built-in power cut circuit (motor driver 1 only)

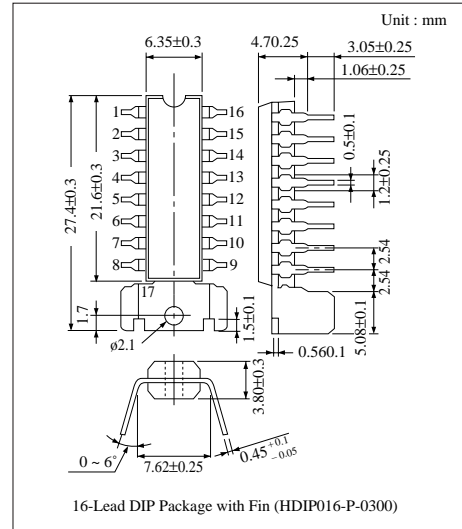

### ■ Applications

Linear driving of the DC motors and actuators of the CD players, CD radio cassette tape recorder, and so on.

### ■ Block Diagram

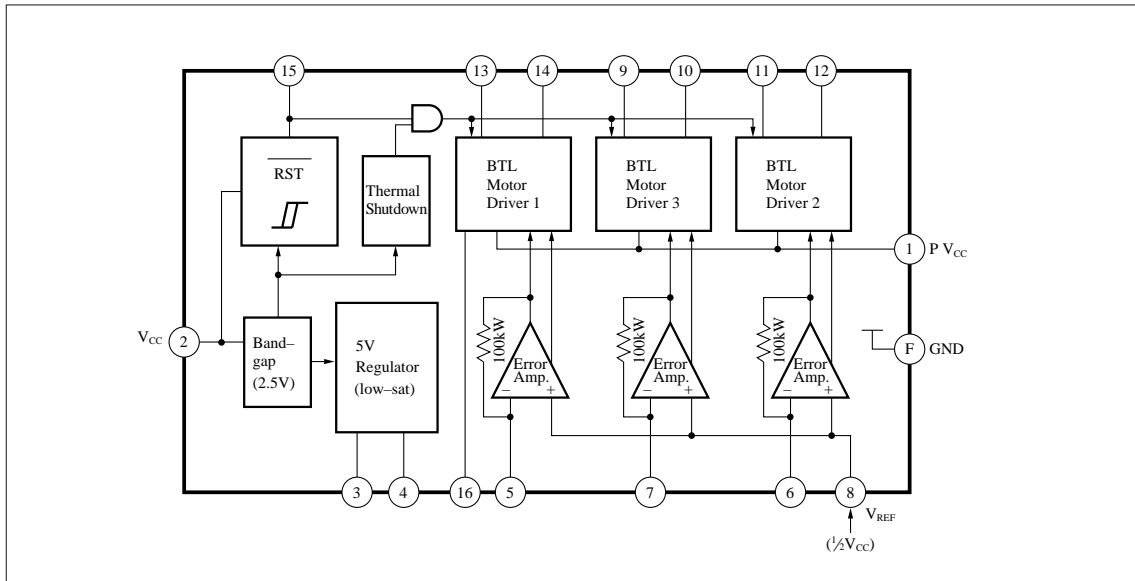

### ■ Absolute Maximum Ratings (Ta=25°C)

Parameter	Symbol	Rating	Unit
Supply Voltage	V <sub>CC</sub>	20	V
Power Dissipation	P <sub>D</sub>	1500	mW
Operating Ambient Temperature	T <sub>opr</sub>	-25 ~ +80	°C
Storage Temperature	T <sub>stg</sub>	-55 ~ +150	°C

### ■ Recommended Operating Range (Ta=25°C)

Parameter	Symbol	Range
Operating Supply Voltage Range	V <sub>CC</sub>	5.5V ~ 16V

### ■ Electrical Characteristics (Ta=25°C)

Parameter	Symbol	Condition	min.	typ.	max.	Unit
No Load Current	I <sub>CC</sub>	V <sub>CC</sub> =12V	7	10.5	15	mA
5V Regulator Output Voltage	V <sub>RO</sub>	V <sub>CC</sub> =12V, R <sub>L</sub> =50W	4.75	5	5.25	V
5V Regulator Load Change	DV <sub>RI</sub>	V <sub>CC</sub> =12V, R <sub>L</sub> =50W ~ 25W	-15	—	30	mV
5V Regulator Input Change	DV <sub>RVC</sub>	V <sub>CC</sub> =15.5V ~ 5.5V, R <sub>L</sub> =50W	-15	—	50	mV
Reset Threshold Voltage	V <sub>RST</sub>		4.55	4.82	5.1	V
Reset Threshold Hysteresis Width	V <sub>HYS</sub>		90	170	310	mV
Reset Operating Minimum Voltage	V <sub>R (min.)</sub>	Minimum V <sub>CC</sub> Voltage at which V15=Low	3.1	—	—	V
Input Offset Voltage	V <sub>IOF</sub>	V <sub>CC</sub> =18V, R <sub>L</sub> =20W, R <sub>IN</sub> =10kW	-7	—	7	mV
Output Offset Voltage	V <sub>OOF</sub>	V <sub>CC</sub> =18V, R <sub>L</sub> =20W, R <sub>IN</sub> =10kW	-50	—	50	mV
Gain (+)	G <sub>+</sub>	V <sub>CC</sub> =18V, R <sub>L</sub> =20W, R <sub>IN</sub> =10kW	16.5	20	22.5	dB
(+) (-) Relative Gain	G <sub>R</sub>	V <sub>CC</sub> =18V, R <sub>L</sub> =20W, R <sub>IN</sub> =10kW	-0.85	—	0.85	dB
Limit Voltage (+)	V <sub>L+</sub>	V <sub>CC</sub> =18V, R <sub>L</sub> =20W, R <sub>IN</sub> =10kW	7.1	—	10.9	V
Limit Voltage (-)	V <sub>L-</sub>	V <sub>CC</sub> =18V, R <sub>L</sub> =20W, R <sub>IN</sub> =10kW	-10.9	—	-7.1	V
Dead Zone Width	V <sub>DZ</sub>	V <sub>CC</sub> =18V, R <sub>L</sub> =20W, R <sub>IN</sub> =10kW	-10	—	30	mV
PC Input Threshold (L)	V <sub>PCL</sub>	V <sub>CC</sub> =18V	—	—	1.2	V
PC Input Threshold (H)	V <sub>PCH</sub>	V <sub>CC</sub> =18V	2.8	—	—	V
Motor Driver 2 Output Voltage at Reset	V <sub>2RS</sub>	V <sub>CC</sub> =3.5V, R <sub>L</sub> =10kW	-50	—	50	mV
Motor Driver 3 Output Voltage at Reset	V <sub>3RS</sub>	V <sub>CC</sub> =3.5V, R <sub>L</sub> =10kW	-50	—	50	mV
Motor Driver 1 Output Voltage at Reset	V <sub>1RS</sub>	V <sub>CC</sub> =3.5V, R <sub>L</sub> =10kW	-50	—	50	mV
5V Regulator External Transistor Base Current Limit Value	I <sub>3LIM</sub>		9	12	16	mA
Thermal Protective Circuit Operating Temperature Balancing Value	T <sub>THD</sub>		—	159	—	°C
Thermal Protective Circuit Operating Temperature Hysteresis Width	DT <sub>THD</sub>		—	64	—	°C

Note) The specified values of V<sub>IOF</sub>, V<sub>OOF</sub>, G<sub>+</sub>, G<sub>R</sub>, V<sub>L+</sub>, V<sub>L-</sub>, and V<sub>DZ</sub> are common ones for each of the motor driver 1, motor driver 2, and motor driver 3 circuits.

■ Application Circuit

(Used when driving the focus, tracking actuator, and traverse motor)

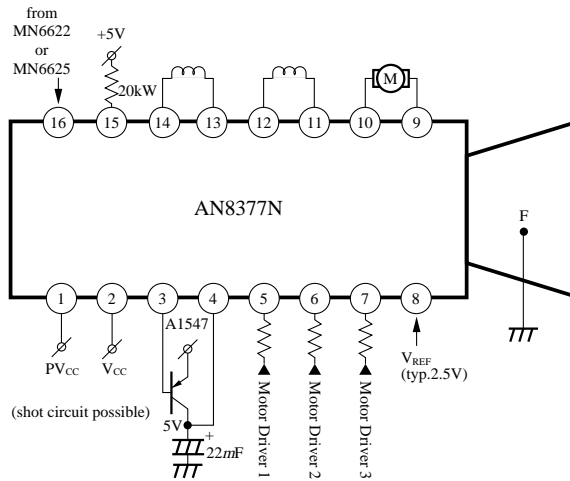

■ Pin Descriptions (The following description applies when the 3 channels for the motor drivers 1, 2, and 3 are used.)

Pin No.	Symbol	I/O	DC Voltage (V <sub>CC</sub> /12V)	Equivalent Circuit	Description
1	PV <sub>CC</sub>	I	12V		Power V <sub>CC</sub> pin. Supplies a current flowing to the output power transistor.
2	V <sub>CC</sub>	I	12V		V <sub>CC</sub> pin. Not connected to the power V <sub>CC</sub> pin.
3	TB	O	11.3V		External PNP transistor base connection pin
4	V <sub>MON</sub>	I	5V		External PNP transistor collector connection pin (=5V output pin)

**Pin Descriptions (Cont.)** (The following description applies when the 3 channels for the motor drivers 1, 2, and 3 are used.)

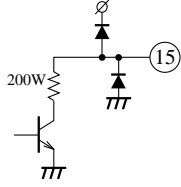
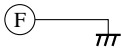
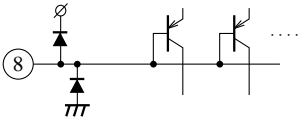
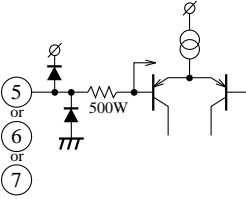
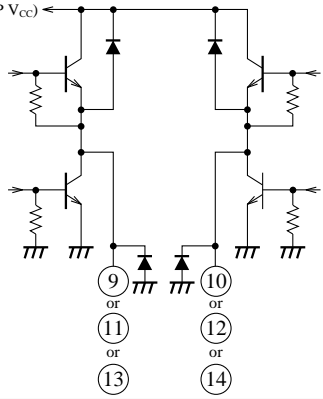
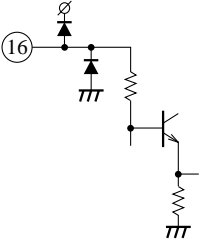
Pin No.	Symbol	I/O	DC Voltage (V <sub>CC</sub> /12V)	Equivalent Circuit	Description	
15	$\overline{\text{RST}}$	O	—		Reset output pin. Open collector output type.	
F	GND	I	0V		GND pin	
8	V <sub>REF</sub>	I	2.5V		V <sub>REF</sub> input pin	
5	TVDI	I	2.5V		Driver 1 error input pin	
6	FDI	I	2.5V		Driver 2 error input pin	
7	TDI	I	2.5V		Driver 3 error input pin	
9	TD-	O	(0.3V)		BTL driver 3 inverting output pin	
10	TD+	O	(0.3V)		BTL driver 3 non-inverting output pin	
11	FD-	O	(0.3V)		BTL driver 2 inverting output pin	
12	FD+	O	(0.3V)		BTL driver 2 non-inverting output pin	
13	TVD-	O	(0V)		BTL driver 1 inverting output pin	
14	TVD+	O	(0V)		BTL driver 1 non-inverting output pin	
16	PC	I	0V			PC (power cut) input pin