

Features

- Serial Peripheral Interface (SPI) Compatible
- Supports SPI Modes 0 (0,0) and 3 (1,1)
- Low-voltage and Standard-voltage Operation
 - 5.0 ($V_{CC} = 4.5V$ to $5.5V$)
 - 2.7 ($V_{CC} = 2.7V$ to $5.5V$)
- 3.0 MHz Clock Rate (5V)
- 8-byte Page Mode
- Block Write Protection
 - Protect 1/4, 1/2, or Entire Array
- Write Protect (WP) Pin and Write Disable Instructions for Both Hardware and Software Data Protection
- Self-timed Write Cycle (10 ms max)
- High Reliability
 - Endurance: One Million Write Cycles
 - Data Retention: 100 Years
 - ESD Protection: >4000V
- Automotive Grade and Extended Temperature Devices Available
- 8-pin PDIP and 8-lead JEDEC SOIC Package

Description

The AT25010/020/040 provides 1024/2048/4096 bits of serial electrically erasable programmable read only memory (EEPROM) organized as 128/256/512 words of 8 bits each. The device is optimized for use in many industrial and commercial applications where low-power and low voltage operation are essential. The AT25010/020/040 is available in space saving 8-pin PDIP and 8-lead JEDEC (SOIC) packages.

The AT25010/020/040 is enabled through the Chip Select pin (\overline{CS}) and accessed via a 3-wire interface consisting of Serial Data Input (SI), Serial Data Output (SO), and Serial Clock (SCK). All programming cycles are completely self-timed, and no separate ERASE cycle is required before WRITE.

BLOCK WRITE protection is enabled by programming the status register with one of four blocks of write protection. Separate program enable and program disable instructions are provided for additional data protection. Hardware data protection is provided via the WP pin to protect against inadvertent write attempts. The HOLD pin may be used to suspend any serial communication without resetting the serial sequence.

Pin Configurations

Pin Name	Function
\overline{CS}	Chip Select
SCK	Serial Data Clock
SI	Serial Data Input
SO	Serial Data Output
GND	Ground
VCC	Power Supply
\overline{WP}	Write Protect
\overline{HOLD}	Suspends Serial Input

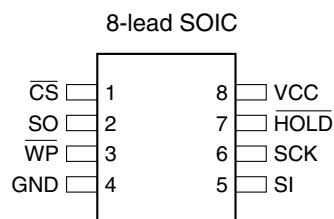
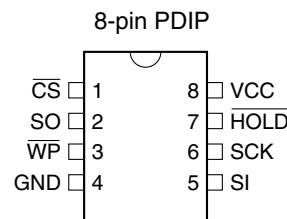

SPI Serial EEPROMs

1K (128 x 8)

2K (256 x 8)

4K (512 x 8)

AT25010

AT25020

AT25040



Absolute Maximum Ratings*

Operating Temperature.....	-40°C to + 125°C
Storage Temperature.....	-65°C to + 150°C
Voltage on Any Pin with Respect to Ground.....	-1.0V to + 7.0V
Maximum Operating Voltage.....	6.25V
DC Output Current.....	5.0 mA

*NOTICE: Stresses beyond those listed under “Absolute Maximum Ratings” may cause permanent damage to the device. This is a stress rating only and functional operation of the device at these or any other conditions beyond those indicated in the operational sections of this specification is not implied. Exposure to absolute maximum rating conditions for extended periods may affect device reliability.

Block Diagram

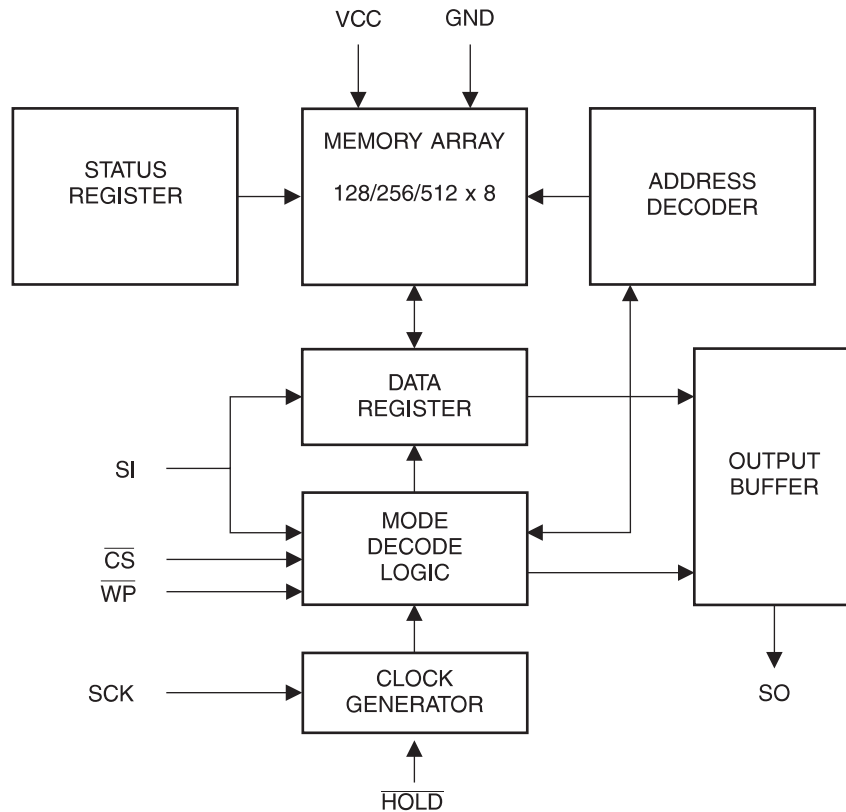

Pin Capacitance⁽¹⁾

Applicable over recommended operating range from $T_A = 25^\circ\text{C}$, $f = 1.0\text{ MHz}$, $V_{CC} = +5.0\text{V}$ (unless otherwise noted).

Symbol	Test Conditions	Max	Units	Conditions
C_{OUT}	Output Capacitance (SO)	8	pF	$V_{OUT} = 0\text{V}$
C_{IN}	Input Capacitance (\overline{CS} , SCK, SI, \overline{WP} , \overline{HOLD})	6	pF	$V_{IN} = 0\text{V}$

Note: 1. This parameter is characterized and is not 100% tested.

DC Characteristics

Applicable over recommended operating range from: $T_{AI} = -40^\circ\text{C}$ to $+85^\circ\text{C}$, $V_{CC} = +2.7\text{V}$ to $+5.5\text{V}$, $T_{AC} = 0^\circ\text{C}$ to $+70^\circ\text{C}$, $V_{CC} = +1.8\text{V}$ to $+5.5\text{V}$ (unless otherwise noted).

Symbol	Parameter	Test Condition	Min	Max	Units
V_{CC1}	Supply Voltage		2.7	5.5	V
V_{CC2}	Supply Voltage		4.5	5.5	V
I_{CC1}	Supply Current	$V_{CC} = 5.0\text{V}$ at 1 MHz, SO = Open, Read		3.0	mA
I_{CC2}	Supply Current	$V_{CC} = 5.0\text{V}$ at 2 MHz, SO = Open, Read, Write		6.0	mA
I_{SB1}	Standby Current	$V_{CC} = 2.7\text{V}$ $\overline{CS} = V_{CC}$		5	μA
I_{SB2}	Standby Current	$V_{CC} = 5.0\text{V}$ $\overline{CS} = V_{CC}$		10	μA
I_{IL}	Input Leakage	$V_{IN} = 0\text{V}$ to V_{CC}	-0.6	3.0	μA
I_{OL}	Output Leakage	$V_{IN} = 0\text{V}$ to V_{CC} , $T_{AC} = 0^\circ\text{C}$ to 70°C	-0.6	3.0	μA
$V_{IL}^{(2)}$	Input Low Voltage		-0.6	$V_{CC} \times 0.3$	V
$V_{IH}^{(2)}$	Input High Voltage		$V_{CC} \times 0.7$	$V_{CC} + 0.5$	V
V_{OL1}	Output Low Voltage	$4.5\text{V} \leq V_{CC} \leq 5.5\text{V}$	$I_{OL} = 2.0\text{ mA}$	0.4	V
V_{OH1}	Output High Voltage		$I_{OH} = -1.0\text{ mA}$	$V_{CC} - 0.8$	V
V_{OL2}	Output Low Voltage	$2.7\text{V} \leq V_{CC} \leq 5.5\text{V}$	$I_{OL} = 0.15\text{ mA}$	0.2	V
V_{OH2}	Output High Voltage		$I_{OH} = -100\ \mu\text{A}$	$V_{CC} - 0.2$	V

Notes: 1. This parameter is preliminary and Atmel may change the specifications upon further characterization.

2. V_{IL} min and V_{IH} max are reference only and are not tested.



AC Characteristics

Applicable over recommended operating range from $T_A = -40^{\circ}\text{C}$ to $+85^{\circ}\text{C}$, $V_{CC} = \text{As Specified}$,
 $CL = 1$ TTL Gate and 100 pF (unless otherwise noted).

Symbol	Parameter	Voltage	Min	Max	Units
f_{SCK}	SCK Clock Frequency	4.5 - 5.5 2.7 - 5.5	0 0	3.0 2.1	MHz
t_{RI}	Input Rise Time	4.5 - 5.5 2.7 - 5.5		2 2	μs
t_{FI}	Input Fall Time	4.5 - 5.5 2.7 - 5.5		2 2	μs
t_{WH}	SCK High Time	4.5 - 5.5 2.7 - 5.5	133 200		ns
t_{WL}	SCK Low Time	4.5 - 5.5 2.7 - 5.5	133 200		ns
t_{CS}	$\overline{\text{CS}}$ High Time	4.5 - 5.5 2.7 - 5.5	250 250		ns
t_{CSS}	$\overline{\text{CS}}$ Setup Time	4.5 - 5.5 2.7 - 5.5	250 250		ns
t_{CSH}	$\overline{\text{CS}}$ Hold Time	4.5 - 5.5 2.7 - 5.5	250 250		ns
t_{SU}	Data In Setup Time	4.5 - 5.5 2.7 - 5.5	50 50		ns
t_{H}	Data In Hold Time	4.5 - 5.5 2.7 - 5.5	50 100		ns
t_{HD}	$\overline{\text{Hold}}$ Setup Time	4.5 - 5.5 2.7 - 5.5	100 100		ns
t_{CD}	$\overline{\text{Hold}}$ Hold Time	4.5 - 5.5 2.7 - 5.5	200 200		ns
t_{V}	Output Valid	4.5 - 5.5 2.7 - 5.5	0 0	133 400	ns
t_{HO}	Output Hold Time	4.5 - 5.5 2.7 - 5.5	0 0		ns
t_{LZ}	$\overline{\text{Hold}}$ to Output Low Z	4.5 - 5.5 2.7 - 5.5	0 0	100 100	ns
t_{HZ}	$\overline{\text{Hold}}$ to Output High Z	4.5 - 5.5 2.7 - 5.5		100 100	ns
t_{DIS}	Output Disable Time	4.5 - 5.5 2.7 - 5.5		250 500	ns
t_{WC}	Write Cycle Time	4.5 - 5.5 2.7 - 5.5		5 10	ms
Endurance ⁽¹⁾	5.0V, 25°C, Page Mode		1M		Write Cycles

Note: 1. This parameter is characterized and is not 100% tested.

Serial Interface Description

MASTER: The device that generates the serial clock.

SLAVE: Because the Serial Clock pin (SCK) is always an input, the AT25010/020/040 always operates as a slave.

TRANSMITTER/RECEIVER: The AT25010/020/040 has separate pins designated for data transmission (SO) and reception (SI).

MSB: The Most Significant Bit (MSB) is the first bit transmitted and received.

SERIAL OP-CODE: After the device is selected with \overline{CS} going low, the first byte will be received. This byte contains the op-code that defines the operations to be performed. The op-code also contains address bit A8 in both the READ and WRITE instructions.

INVALID OP-CODE: If an invalid op-code is received, no data will be shifted into the AT25010/020/040, and the serial output pin (SO) will remain in a high impedance state until the falling edge of \overline{CS} is detected again. This will reinitialize the serial communication.

CHIP SELECT: The AT25010/020/040 is selected when the \overline{CS} pin is low. When the device is not selected, data will not be accepted via the SI pin, and the serial output pin (SO) will remain in a high impedance state.

HOLD: The \overline{HOLD} pin is used in conjunction with the \overline{CS} pin to select the AT25010/020/040. When the device is selected and a serial sequence is underway, \overline{HOLD} can be used to pause the serial communication with the master device without resetting the serial sequence. To pause, the \overline{HOLD} pin must be brought low while the SCK pin is low. To resume serial communication, the \overline{HOLD} pin is brought high while the SCK pin is low (SCK may still toggle during \overline{HOLD}). Inputs to the SI pin will be ignored while the SO pin is in the high impedance state.

WRITE PROTECT: The write protect pin (\overline{WP}) will allow normal read/write operations when held high. When the \overline{WP} pin is brought low, all write operations are inhibited.

\overline{WP} going low while \overline{CS} is still low will interrupt a write to the AT25010/020/040. If the internal write cycle has already been initiated, \overline{WP} going low will have no effect on any write operation.

SPI Serial Interface

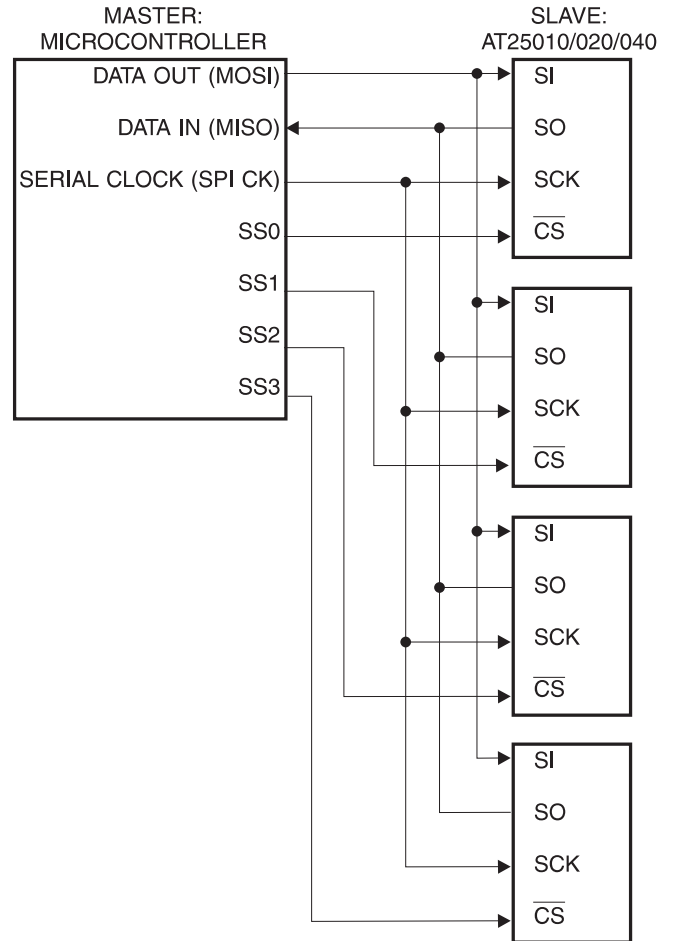

Functional Description

The AT25010/020/040 is designed to interface directly with the synchronous serial peripheral interface (SPI) of the 6805 and 68HC11 series of microcontrollers.

The AT25010/020/040 utilizes an 8-bit instruction register. The list of instructions and their operation codes are contained in Table 1. All instructions, addresses, and data are transferred with the MSB first and start with a high-to-low CS transition.

Table 1. Instruction Set for the AT25010/020/040

Instruction Name	Instruction Format	Operation
WREN	0000 X110	Set Write Enable Latch
WRDI	0000 X100	Reset Write Enable Latch
RDSR	0000 X101	Read Status Register
WRSR	0000 X001	Write Status Register
READ	0000 A011	Read Data from Memory Array
WRITE	0000 A010	Write Data to Memory Array

Note: "A" represents MSB address bit A8.

WRITE ENABLE (WREN): The device will power up in the write disable state when V_{CC} is applied. All programming instructions must therefore be preceded by a Write Enable instruction. The \overline{WP} pin must be held high during a WREN instruction.

WRITE DISABLE (WRDI): To protect the device against inadvertent writes, the Write Disable instruction disables all programming modes. The WRDI instruction is independent of the status of the \overline{WP} pin.

READ STATUS REGISTER (RDSR): The Read Status Register instruction provides access to the status register. The READY/BUSY and Write Enable status of the device can be determined by the RDSR instruction. Similarly, the Block Write Protection bits indicate the extent of protection employed. These bits are set by using the WRSR instruction.

Table 2. Status Register Format

Bit 7	Bit 6	Bit 5	Bit 4	Bit 3	Bit 2	Bit 1	Bit 0
X	X	X	X	BP1	BP0	WEN	\overline{RDY}

Table 3. Read Status Register Bit Definition

Bit	Definition
Bit 0 (\overline{RDY})	Bit 0 = 0 (\overline{RDY}) indicates the device is READY. Bit 0 = 1 indicates the write cycle is in progress.
Bit 1 (WEN)	Bit 1 = 0 indicates the device <i>is not</i> WRITE ENABLED. Bit 1 = 1 indicates the device is WRITE ENABLED.
Bit 2 (BP0)	See Table 4.
Bit 3 (BP1)	See Table 4.
Bits 4-7 are 0s when device is not in an internal write cycle.	
Bits 0-7 are 1s during an internal write cycle.	

WRITE STATUS REGISTER (WRSR): The WRSR instruction allows the user to select one of four levels of protection. The AT25010/020/040 is divided into four array segments. Top quarter (1/4), Top half (1/2), or all of the memory segments can be protected. Any of the data within any selected segment will therefore be READ only. The block write protection levels and corresponding status register control bits are shown in Table 4.

The two bits, BP1 and BP0 are nonvolatile cells that have the same properties and functions as the regular memory cells (e.g. WREN, t_{WC} , RDSR).

Table 4. Block Write Protect Bits

Level	Status Register Bits		Array Addresses Protected		
	BP1	BP0	AT25010	AT25020	AT25040
0	0	0	None	None	None
1 (1/4)	0	1	60-7F	C0-FF	180-1FF
2 (1/2)	1	0	40-7F	80-FF	100-1FF
3 (All)	1	1	00-7F	00-FF	000-1FF

READ SEQUENCE (READ): Reading the AT25010/020/040 via the SO (Serial Output) pin requires the following sequence. After the \overline{CS} line is pulled low to select a device, the READ op-code (including A8) is transmitted via the SI line followed by the byte address to be read (A7-A0). Upon completion, any data on the SI line will be ignored. The data (D7-D0) at the specified address is then shifted out onto the SO line. If only one byte is to be read, the \overline{CS} line should be driven high after the data comes out. The READ sequence can be continued since the byte address is automatically incremented and data will continue to be shifted out. When the highest address is reached, the address counter will roll over to the lowest address allowing the entire memory to be read in one continuous READ cycle.

WRITE SEQUENCE (WRITE): In order to program the AT25010/020/040, the Write Protect pin (\overline{WP}) must be held high and two separate instructions must be executed. First, the device **must be write enabled** via the Write Enable (WREN) Instruction. Then a Write (WRITE) Instruction may be executed. Also, the address of the memory location(s) to be programmed must be outside the protected address field location selected by the Block Write Protection Level. During an internal write cycle, all commands will be ignored except the RDSR instruction.

A Write Instruction requires the following sequence. After the \overline{CS} line is pulled low to select the device, the WRITE op-code (including A8) is transmitted via the SI line followed by the byte address (A7-A0) and the data (D7-D0) to be programmed. Programming will start after the \overline{CS} pin is brought high. (The LOW to High transition of the \overline{CS} pin must occur during the SCK low time immediately after clocking in the D0 (LSB) data bit.

The READY/BUSY status of the device can be determined by initiating a READ STATUS REGISTER (RDSR) Instruc-

tion. If Bit 0 = 1, the WRITE cycle is still in progress. If Bit 0 = 0, the WRITE cycle has ended. Only the READ STATUS REGISTER instruction is enabled during the WRITE programming cycle.

The AT25010/020/040 is capable of an 8-byte PAGE WRITE operation. After each byte of data is received, the three low order address bits are internally incremented by one; the six high order bits of the address will remain constant. If more than 8 bytes of data are transmitted, the address counter will roll over and the previously written data will be overwritten. The AT25010/020/040 is automatically returned to the write disable state at the completion of a WRITE cycle.

NOTE: If the \overline{WP} pin is brought low or if the device is not Write enabled (WREN), the device will ignore the Write instruction and will return to the standby state, when \overline{CS} is brought high. A new CS falling edge is required to re-initiate the serial communication.

Timing Diagrams

Synchronous Data Timing (for mode 0)

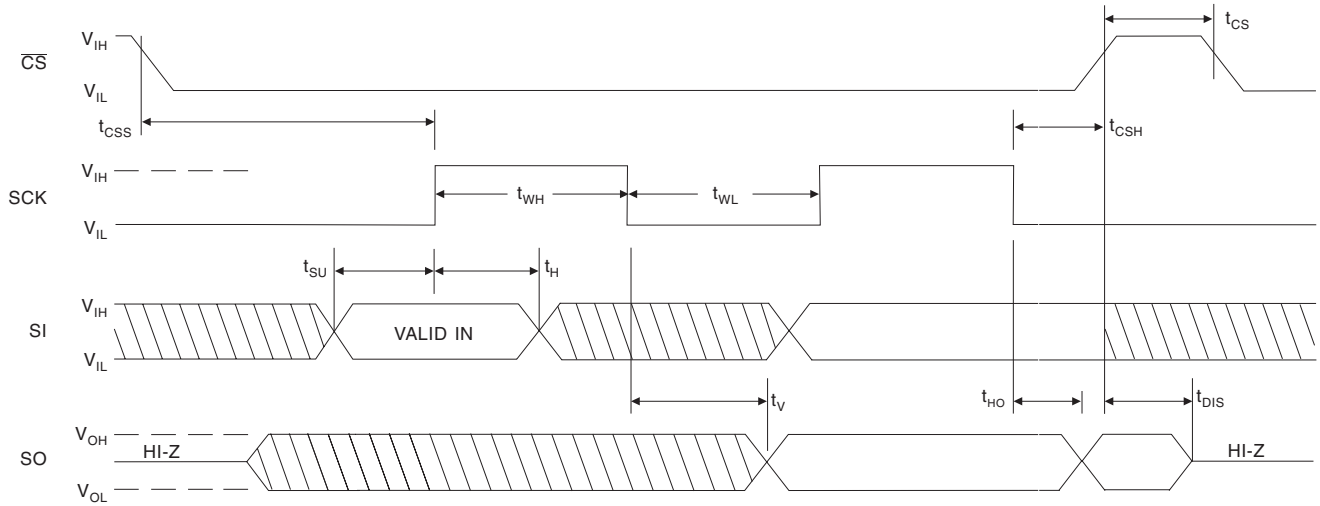

WREN Timing

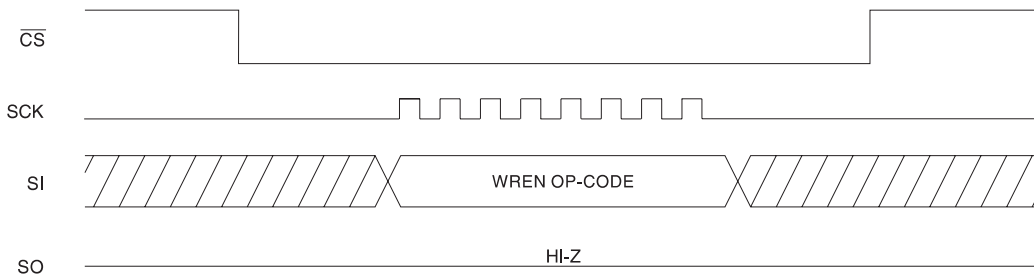

WRDI Timing

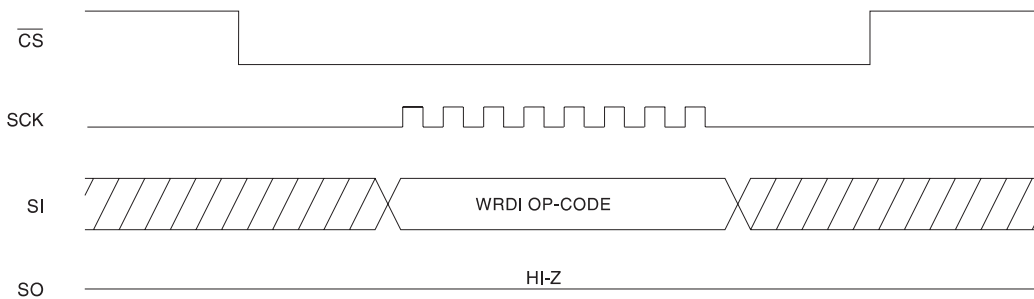

RDSR Timing

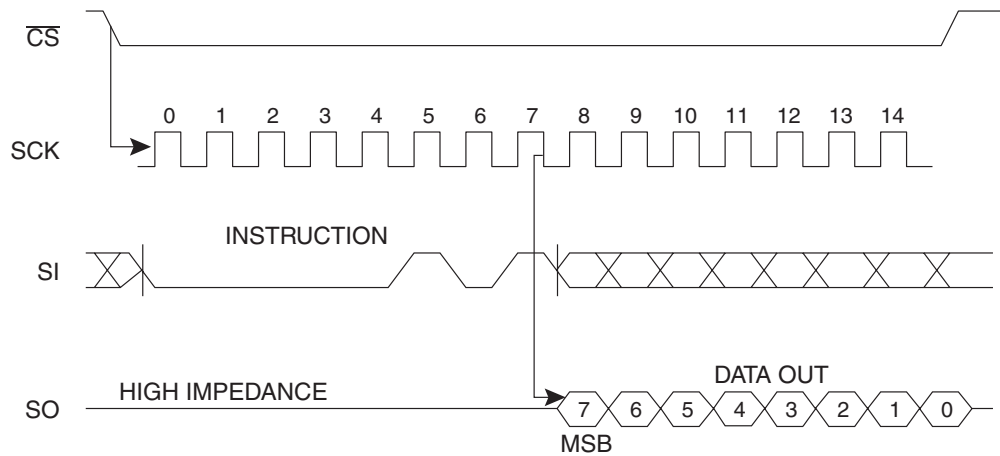

WRSR Timing

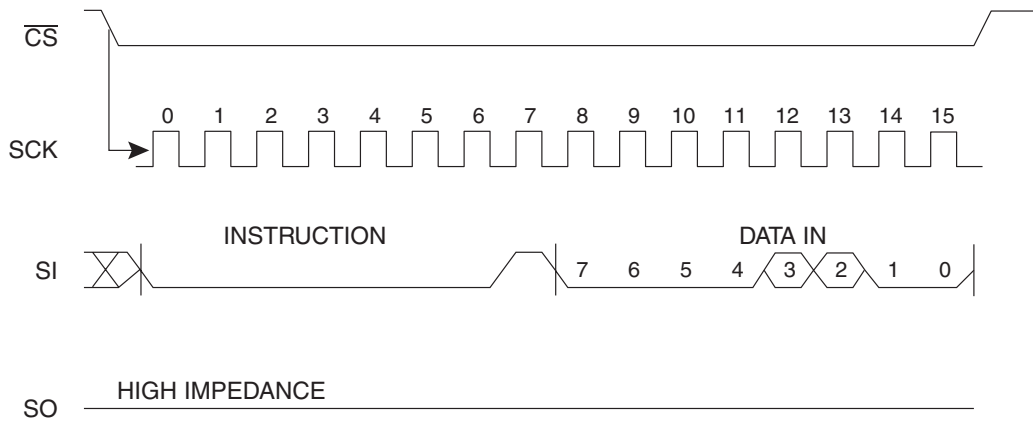

READ Timing

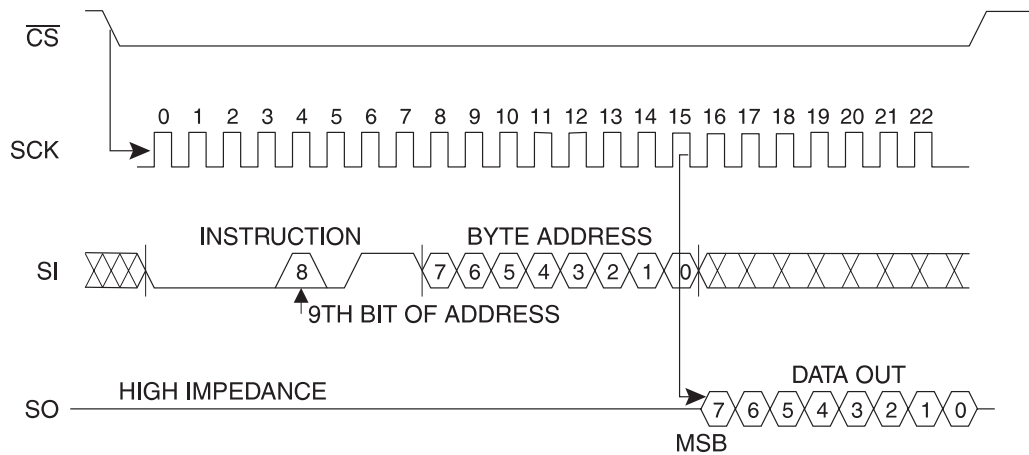

WRITE Timing

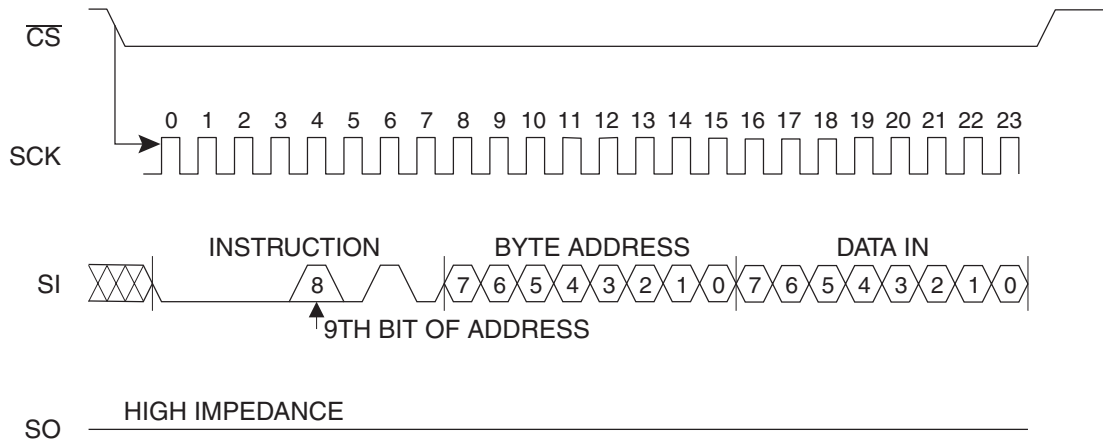

HOLD Timing

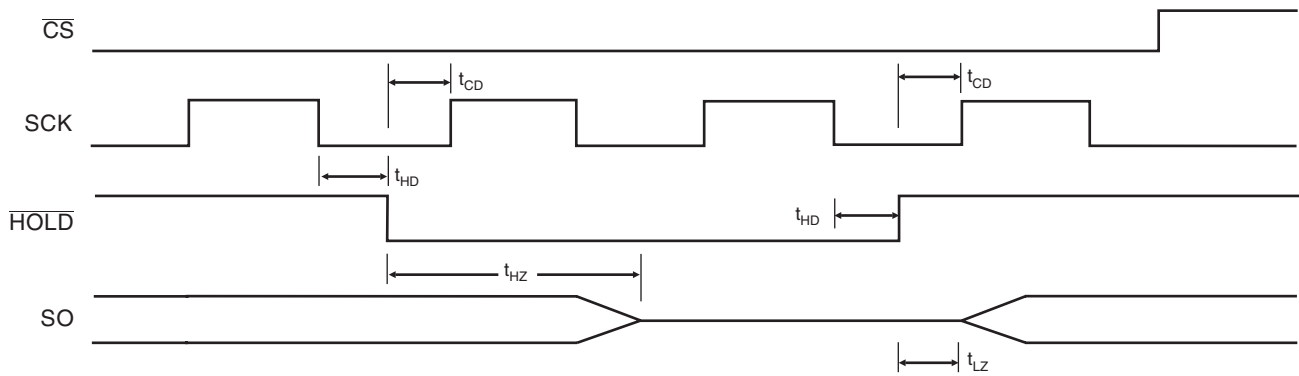

AT25010 Ordering Information

t_{WC} (max) (ms)	I_{CC} (max) (μA)	I_{SB} (max) (μA)	f_{MAX} (kHz)	Ordering Code	Package	Operation Range
5	6000	100	3000	AT25010-10PC AT25010N-10SC	8P3 8S1	Commercial (0°C to 70°C)
		100	3000	AT25010-10PI AT25010N-10SI	8P3 8S1	Industrial (-40°C to 85°C)
10	3000	100	2100	AT25010-10PC-2.7 AT25010N-10SC-2.7	8P3 8S1	Commercial (0°C to 70°C)
		100	2100	AT25010-10PI-2.7 AT25010N-10SI-2.7	8P3 8S1	Industrial (-40°C to 85°C)

Package Type	
8P3	8-pin, 0.300" Wide, Plastic Dual Inline Package (PDIP)
8S1	8-lead, 0.150" Wide, Plastic Gull Wing Small Outline Package (JEDEC SOIC)
Options	
Blank	Standard Device (4.5V to 5.5V)
-2.7	Low Voltage (2.7V to 5.5V)





AT25020 Ordering Information

t_{WC} (max) (ms)	I_{CC} (max) (μA)	I_{SB} (max) (μA)	f_{MAX} (kHz)	Ordering Code	Package	Operation Range
5	6000	100	3000	AT25020-10PC AT25020N-10SC	8P3 8S1	Commercial (0°C to 70°C)
		100	3000	AT25020-10PI AT25020N-10SI	8P3 8S1	Industrial (-40°C to 85°C)
10	3000	100	2100	AT25020-10PC-2.7 AT25020N-10SC-2.7	8P3 8S1	Commercial (0°C to 70°C)
		100	2100	AT25020-10PI-2.7 AT25020N-10SI-2.7	8P3 8S1	Industrial (-40°C to 85°C)

Package Type	
8P3	8-lead, 0.300" Wide, Plastic Dual Inline Package (PDIP)
8S1	8-lead, 0.150" Wide, Plastic Gull Wing Small Outline Package (JEDEC SOIC)
Options	
Blank	Standard Device (4.5V to 5.5V)
-2.7	Low Voltage (2.7V to 5.5V)

AT25040 Ordering Information

$t_{WC}(max)$ (ms)	$I_{CC}(max)$ (μA)	$I_{SB}(max)$ (μA)	f_{MAX} (kHz)	Ordering Code	Package	Operation Range
5	6000	100	3000	AT25040-10PC AT25040N-10SC	8P3 8S1	Commercial (0°C to 70°C)
		100	3000	AT25040-10PI AT25040N-10SI	8P3 8S1	Industrial (-40°C to 85°C)
10	3000	100	2100	AT25040-10PC-2.7 AT25040N-10SC-2.7	8P3 8S1	Commercial (0°C to 70°C)
		100	2100	AT25040-10PI-2.7 AT25040N-10SI-2.7	8P3 8S1	Industrial (-40°C to 85°C)

Package Type	
8P3	8-pin, 0.300" Wide, Plastic Dual Inline Package (PDIP)
8S1	8-lead, 0.150" Wide, Plastic Gull Wing Small Outline Package (JEDEC SOIC)
Options	
Blank	Standard Device (4.5V to 5.5V)
-2.7	Low Voltage (2.7V to 5.5V)



Packaging Information

8P3, 8-pin, 0.300" Wide, Plastic Dual Inline Package (PDIP)

Dimensions in Inches and (Millimeters)
JEDEC STANDARD MS-001 BA

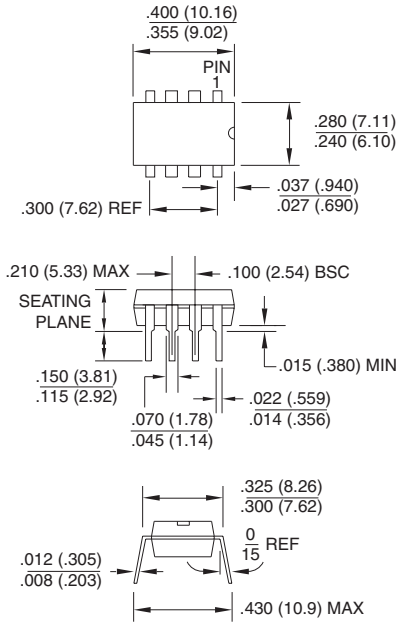

8S1, 8-lead, 0.150" Wide, Plastic Gull Wing Small Outline (JEDEC SOIC)

Dimensions in Inches and (Millimeters)

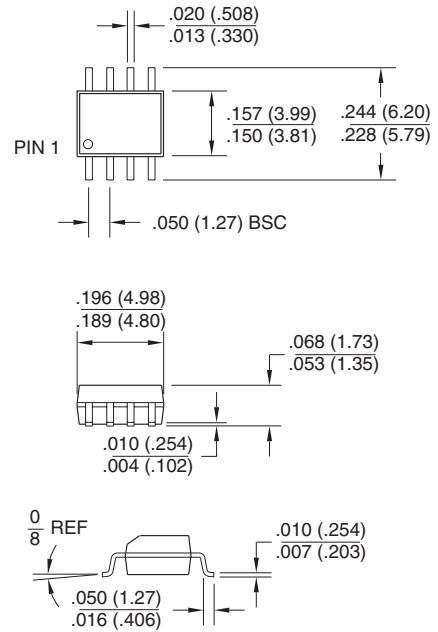



Atmel Headquarters

Corporate Headquarters

2325 Orchard Parkway
San Jose, CA 95131
TEL (408) 441-0311
FAX (408) 487-2600

Europe

Atmel SarL
Route des Arsenaux 41
Casa Postale 80
CH-1705 Fribourg
Switzerland
TEL (41) 26-426-5555
FAX (41) 26-426-5500

Asia

Atmel Asia, Ltd.
Room 1219
Chinachem Golden Plaza
77 Mody Road Tsimhatsui
East Kowloon
Hong Kong
TEL (852) 2721-9778
FAX (852) 2722-1369

Japan

Atmel Japan K.K.
9F, Tonetsu Shinkawa Bldg.
1-24-8 Shinkawa
Chuo-ku, Tokyo 104-0033
Japan
TEL (81) 3-3523-3551
FAX (81) 3-3523-7581

Atmel Operations

Atmel Colorado Springs

1150 E. Cheyenne Mtn. Blvd.
Colorado Springs, CO 80906
TEL (719) 576-3300
FAX (719) 540-1759

Atmel Rousset

Zone Industrielle
13106 Rousset Cedex
France
TEL (33) 4-4253-6000
FAX (33) 4-4253-6001

Atmel Smart Card ICs

Scottish Enterprise Technology Park
East Kilbride, Scotland G75 0QR
TEL (44) 1355-357-000
FAX (44) 1355-242-743

Atmel Grenoble

Avenue de Rochepleine
BP 123
38521 Saint-Egreve Cedex
France
TEL (33) 4-7658-3000
FAX (33) 4-7658-3480

Fax-on-Demand

North America:
1-(800) 292-8635
International:
1-(408) 441-0732

e-mail

literature@atmel.com

Web Site

<http://www.atmel.com>

BBS

1-(408) 436-4309

© Atmel Corporation 2001.

Atmel Corporation makes no warranty for the use of its products, other than those expressly contained in the Company's standard warranty which is detailed in Atmel's Terms and Conditions located on the Company's web site. The Company assumes no responsibility for any errors which may appear in this document, reserves the right to change devices or specifications detailed herein at any time without notice, and does not make any commitment to update the information contained herein. No licenses to patents or other intellectual property of Atmel are granted by the Company in connection with the sale of Atmel products, expressly or by implication. Atmel's products are not authorized for use as critical components in life support devices or systems.

Marks bearing ® and/or ™ are registered trademarks and trademarks of Atmel Corporation.

Terms and product names in this document may be trademarks of others.



Printed on recycled paper.

Rev. 0606F-03/02/01/xM