

Features

- Compatible with Many Existing Memory Card Applications
- 1-Kbit EEPROM User Memory
 - Two 256 x 1 Application Zones
 - One 512 x 1 Application Zone
 - Protected by Security Logic
 - Vpp Internally Generated for Single Voltage Operation
 - 2 μ s Read Access Time
 - 2 ms Write Cycle (Self-timed)
- Additional EEPROM Memory for Code Storage
 - Three OTP Areas, 144 Bits Total
 - 64-bit Code-protected Zone
- Security Features
 - Stores and Validates Security Codes
 - Maximum of Four Incorrect Security Code Attempts
 - Provides Security Code Protection During Transportation
- High Reliability
 - Endurance: 100,000 Cycles
 - Data Retention: 10 Years
 - ESD Protection: 4,000V Minimum
- Manufactured Using Low-power CMOS Technology
- Temperature Range from -25°C to $+85^{\circ}\text{C}$
- ISO 7816-compliant Card Modules

Description

The AT88SC1003 is a low-cost synchronous integrated circuit, designed for use in prepaid and loyalty smart card applications. The AT88SC1003 provides 1024 bits of serial EEPROM (Electrically Erasable and Programmable Read Only Memory) within three application zones, plus 64 bits in a code-protected zone. Security logic provides access protection through use of a 16-bit security code.

Additional EEPROM memory is available to hold unalterable information about the card history. Separate zones are available for data written by the fabrication facility, card manufacturer and card issuer. After personalization of the memory by the issuer, an internal fuse is blown that secures critical memory areas of the device and configures the IC for use by the end customer. The action of blowing this fuse is irreversible. The AT88SC1003 is manufactured using low-power CMOS technology. EEPROM programming functions are accomplished using an internally generated high-voltage pump for single voltage supply operation. Program timing is controlled internally. Memory endurance is guaranteed to 100,000 erase/write cycles. Ten-year data retention is guaranteed.

Table 1. Pin Configuration

Pad	Description	ISO Module Contact
VCC	Supply Voltage	C1
GND	Ground	C5
CLK	Serial Clock Input	C3
I/O	Serial Data Input/Output	C7
RST	Reset Input	C2
PGM	Program Input	C8
FUS	Fuse Input	C4



**1K Secure
EEPROM
with Three
Application
Zones**

AT88SC1003

Rev. 2035A-SMEM-4/02



Figure 1. Card Module Contact

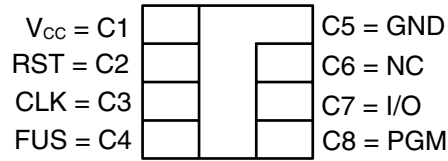
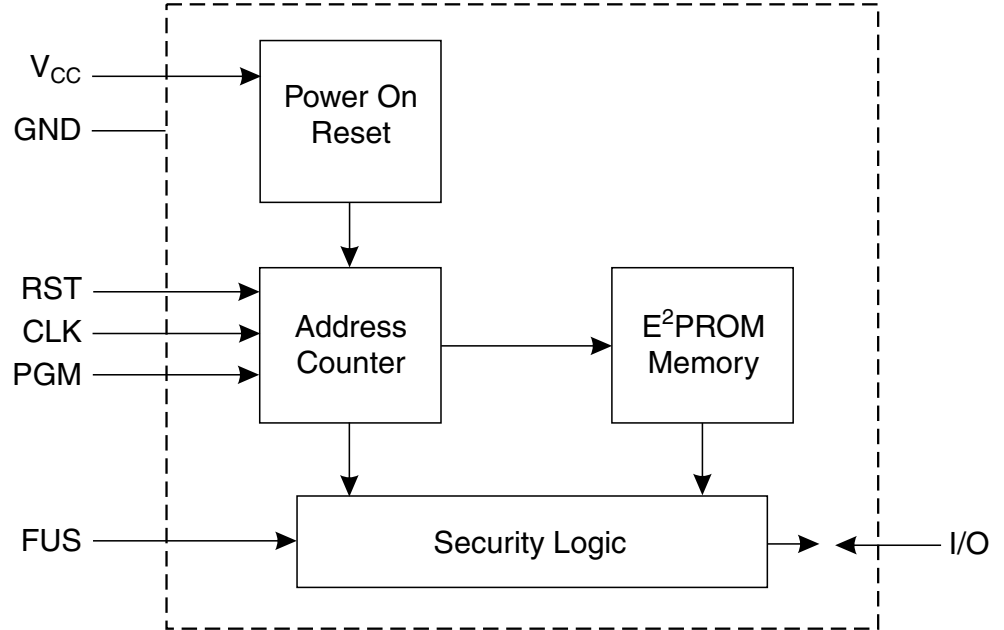

Figure 2. Block Diagram



Pin Descriptions

Supply Voltage (VCC)

The VCC input is a 4.5V to 5.5V positive voltage.

Serial Clock (CLK)

The CLK input is used to positive edge clock data into the device and negative edge clock data out of the device. There is an internal pull-down on CLK.

Serial Data (I/O)

I/O is bidirectional for serial data transfer to and from the device.

Reset (RST)

The RST input is used to reset the address counter. There is an internal pull-up on RST.

Program (PGM)

The PGM input is used to determine the state of I/O as an input or output. There is an internal pull-down on PGM.

Fuse (FUS)

The FUS input is used during the personalization of the device. There is an internal pull-down on FUS.

Security Features

The security features of Atmel’s AT88SC1003 include:

- Data access only after validation of the security code
- Permanent invalidation of device upon four consecutive false security code presentations
- Read/write protection of certain memory zones
- Secure transport of devices using security code compare sequence.

Security Levels

Access to the memory is controlled by the state of the issuer fuse and by the voltage supply applied on the FUS pin.

FUS Pin	Issuer Fuse	Security Level
Logic “0”	X	2
Logic “1”	1	1
Logic “1”	0	2

Level 1: Security During Personalization by the Card Issuer

AT88SC1003 die and modules are delivered with the issuer fuse intact. Issuer personalization is completed at this level. Security code validation is required to allow access to personalize the EEPROM memory. During personalization, the fab zone fuse may be blown to lock the fabrication zone. The manufacturer fuse may be blown to lock the manufacturer’s zone.

See “Memory Access Rules During Personalization” (Table 2 on page 12).

Conditions:

- Issuer fuse = “1” (not blown)
- FUS pin = “1” (required)

Level 2: Security After Personalization (Customer Release)

EEPROM memory zones are protected by the various flags and passwords. After issuer personalization, Security Level 2 is implemented by blowing the issuer fuse. The device can also be placed in Security Level 2 by taking the FUS pin low, independent of the state of the issuer fuse. This function of the FUS pin enables the card issuer to simulate Security Level 2 during application development, without permanently blowing the issuer fuse.

See “Memory Access Rules After Personalization” (Table 3 on page 13).

Conditions:

- Issuer fuse = “0” (blown)
- FUS pin = “X”
- or
- Issuer fuse = “1” (not blown)
- FUS pin = “0”

Memory Diagram

Bit Address	Zone	Bits	Words
0–15	FZ – Fabrication Zone	16 Bits	1
16–79	IZ – Issuer Zone	64 Bits	4
80–95	SC – Security Code	16 Bits	1
96–111	SCAC – Security Code Attempts Counter (only first 4 bits used)	16 Bits	1
112–175	CPZ – Code Protected Zone	64 Bits	4
176–431	AZ1 – Application Zone 1	256 Bits	16
432–479	EZ1 – Application Zone 1 Erase Key	48 Bits	3
480–735	AZ2 – Application Zone 2	256 Bits	16
736–767	EZ2 – Application Zone 2 Erase Key	32 Bits	2
768–895	EC2 – Application Zone 2 Erase Counter	128 Bits	8
896–911	MTZ – Memory Test Zone	16 Bits	1
912–975	MFZ – Manufacturer's Zone	64 Bits	4
992–1007	ISSUER FUSE	16 Bits	1
1012–1015	FAB ZONE FUSE	4 Bits	
1016–1019	MANUF. FUSE – Manufacturer's Fuse	4 Bits	
1020–1023	EC2EN FUSE – Controls use of EC2	4 Bits	
1024–1535	AZ3 – Application Zone 3	512 Bits	32
1536–1583	EZ3 – Application Zone 3 Erase Key	48 Bits	3
1584	EB3 – Application Zone 3 Erase Bit	1 Bit	
1585–1599	Unused	16 Bits	1

Memory Zone Descriptions

Zone	Definition
Fabrication Zone FZ (16 bits)	The 16-bit fabrication zone is initially programmed by Atmel. Prior to blowing the fab zone fuse, the fabrication zone may be rewritten by the card manufacturer. This area becomes read-only after the fab zone fuse is blown. Blowing the issuer fuse will also lock the data in the FZ.
Issuer Zone IZ (64 bits)	The 64-bit issuer zone is programmed by the card issuer during the personalization phase. It will contain issuer-specific information, such as serial numbers and dates. This area becomes read-only after the issuer fuse has been blown. Read access is always allowed in the issuer zone.
Security Code SC (16 bits)	The security code is initially set by Atmel to protect the product during transportation to the card issuer. During personalization, this code must be entered and verified by the AT88SC1003 to allow access to the EEPROM memory. After the security code has been verified, the code itself may be changed in either security mode. The security code gives access to Application Zones 1, 2 and 3, and also gives access to the code-protected zone area for erase and write. Verification of the security code will set the internal flag SV to "1". Atmel ships the device with a security code (transportation code) pre-programmed. This protects against the unauthorized use of an unpersonalized device, and should be written to a new value during initialization.
Security Code Attempts Counter SCAC (4 bits plus 12 unused bits)	The protocol for verification of the security code requires that the user write one of the first four bits of the SCAC to a logic "0". This allows the SCAC to count the number of consecutive incorrect presentations of the security code. After four consecutive incorrect security code presentations, the first four bits of the SCAC will all be written to "0", and the user is permanently blocked from access to the application zones, as well as to other areas controlled by the security code. After a successful presentation of the security code, the entire 16-bit SCAC, including the four active bits, should be erased. This verifies that the correct security code has been presented, since an erase operation in this area is not allowed without SC verification. It also clears the SCAC bits in preparation for the next use of the card. This erase operation will also clear the remaining 12 bits of the 16-bit SCAC word. These 12 bits may be used in an application, although the entire 16-bit word will be erased if any bit in the SCAC is erased.
Code Protected Zone CPZ (64 bits)	Read access to this area is always allowed and does not require SC validation. The security code must be correctly presented to allow write access to the code-protected zone.
Application Zone 1 AZ1 (256 bits)	AZ1 is intended to hold user application data. P1 (address 176) controls write access and R1 (address 177) controls read access within Zone 1. In Security Level 1, erasing AZ1 is accomplished by performing an erase operation on any bit within AZ1, after verification of the security code (SV flag = 1). This operation will erase the entire zone. In Security Level 2, erase operations are controlled by both the SV flag and the erase key EZ1. See the erase definition in the Device Functional Operation chart (page 16) for specific details. There is no limit to the number of erase operations performed in AZ1. In Security Level 1, write operations in AZ1 may be performed on single bits after verification of the security code. In Security Level 2, the P1 bit must also be set to "1" to allow single bit write operations. Read operations in Security Levels 1 and 2 are allowed if either R1 is set to "1" or the SV flag is set to "1" by validating the security code.
Application Zone 1 Erase Key EZ1 (48 bits)	The erase keys are passwords used to control erase operations within the application zones, after the issuer fuse has been blown (Security Level 2). The erase key password is written during personalization (Security Level 1), after verification of the security code. EZ1 can not be changed after the issuer fuse is blown. In Security Level 2, AZ1 can be erased only after both the security code and the EZ1 password have been validated. Verification of EZ1 will set the internal flag E1 to "1".

Memory Zone Descriptions (Continued)

Zone	Definition
Application Zone 2 AZ2 (256 bits)	AZ2 is intended to hold user application data. P2 (address 480) controls write access and R2 (address 481) controls read access within Zone 2. In Security Level 1, erasing AZ2 is accomplished by performing an erase operation on any bit within AZ2, after verification of the security code (SV flag = 1). This operation will erase the entire zone. In Security Level 2, erase operations are controlled by the erase key EZ2, the erase counter EC2 and the EC2EN fuse. If the EC2EN fuse is set to "1", then the erase counter made for Application Zone 2 is enabled, and the user is limited to 128 erase operations on AZ2. If the EC2EN fuse is set to "0", then the erase counter mode is disabled and there is no limit to the number of erase operations on AZ2. The EC2EN fuse must be written during the personalization phase (Security Level 1). After the issuer fuse is blown, the status of the EC2EN fuse cannot be changed. See the erase definition in the Device Functional Operation chart (page 16) for specific details about erase procedure. In Security Level 1, write operations in AZ2 may be performed on single bits after verification of the secure code. In Security Level 2, the P2 bit must also be set to "1" to allow single bit write operations. Read operations in Security Levels 1 and 2 are allowed if either R2 is set to "1" or the SV flag is set to "1" by validating the secure code.
Application Zone 2 Erase Key EZ2 (32 bits)	The erase keys are passwords used to control erase operations within application zones after the issuer fuse has been blown (Security Level 2). The erase key password is written during personalization (Security Level 1), after verification of the security code. EZ2 cannot be changed after the issuer fuse is blown. In Security Level 2, AZ2 can be erased only after both the security code and the EZ2 password have been validated. Verification of EZ2 will set the internal flag E2 to "1".
Application Zone 2 Erase Counter EC2 (128 bits)	The erase counter (EC2) is enabled only in Security Mode 2 and only when the EC2EN fuse is set to "1". If both of these conditions are true, the user will be limited to 128 erase operations in Application Zone 2. EC2 is used to count these erase cycles. The erase protocol for AZ2 requires one bit in EC2 to be written to a "0". After 128 erase operations in AZ2, all 128 bits in EC2 will be "0" and the user will be blocked from erasing AZ2. The erase counter is only writeable and cannot be erased. When the EC2EN fuse = "0", the EC2 operation is disabled. In that case there is no limit to the number of times the AZ2 can be erased, and EC2 has no function.
Memory Test Zone MTZ (16 bits)	All operations are allowed for this zone (write, erase, read). The purpose of this zone is to provide an area in the product memory that is not restricted by security logic. It is used for testing purposes during the manufacturing process and may also be used in the product application if desired, although no security protection exists for the MTZ.
Manufacturer's Zone MFZ (64 bits)	The MFZ is intended to hold data specific to the smart card manufacturer (like assembly lot codes, dates, etc.). Read operations within this zone are always allowed. Write or erase operations within this zone are allowed after the security code has been verified. After the data is entered by the card manufacturer, the manufacturer's fuse can be blown and the data within the MFZ will become read-only. Blowing the issuer fuse will also lock the data in the MFZ.
EC2EN Fuse (4 bits)	This single bit EEPROM fuse selects whether the EC2 counter is used to limit the number of AZ2 erases in Security Mode 2. If the EC2EN fuse is unblown ("1"), the number of erases of AZ2 is limited to 128. If the EC2EN fuse is blown ("0"), there is no limit to the number of erase operations in AZ2. After the issuer fuse is blown, the state of the EC2EN fuse is locked and cannot be changed.
Issuer Fuse (16 bits)	This EEPROM bit functions as a fuse that is used to change the security mode of the AT88SC1003 from Security Mode 1 ("1"), to Security Mode 2 ("0"). Initialization of the IC for use by the end customer occurs in Security Mode 1. Access conditions in Security Mode 1 are described in Table 2 (page 12). Access conditions in Security Mode 2 are described in Table 3 (page 13).

Memory Zone Descriptions (Continued)

Zone	Definition
Application Zone 3 AZ3 (512 bits)	AZ3 is intended to hold user application data. P3 (address 1024) controls write access and R3 (address 1025) controls read access within Zone 3. In Security Level 1, erasing AZ3 is accomplished by performing an erase operation on any bit within AZ3, after verification of the security code (SV flag = 1). This operation will erase the entire zone. In Security Level 2, erase operations are controlled by both the SV flag and the erase key EZ3. See the device operation erase definition for specific details. There is no limit to the number of erase operations performed in AZ3. In Security Level 1, write operations in AZ3 may be performed on single bits after verification of the security code. In Security Level 2, the P3 bit must also be set to “1” to allow single bit write operations. Read operations in Security Levels 1 and 2 are allowed if either R3 is set to “1” or the SV flag is set to “1” by validating the security code.
Application Zone 3 Erase key EZ3 (1 bit)	The erase keys are passwords used to control erase operations within the application zones, after the issuer fuse has been blown (Security Level 2). The erase key password is written during personalization (Security Level 1), after verification of the security code. EZ3 can not be changed after the issuer fuse is blown. In Security Level 2, AZ3 can be erased only after both the security code and the EZ3 password have been validated. Verification of EZ3 will set the internal flag E3 to “1”.
Application Zone 3 Erase Bit EB3 (1 bit)	Address location 1584 is designated as the erase bit for Application Zone 3. The erase protocol for an AT88SC1003 in Security Mode 2 requires that the erase key (EZ3) be verified, then an erase operation must be executed on the next bit following the erase key. This action will result in erasing the entire zone.
Unused (16 bits)	Address locations 1585–1599 are not functional in the AT88SC1003. If the address counter is incremented beyond address 1599, the counter will roll over to address 0. The counter can also be reset to “0” by executing a reset command.

Terminology

The following terms have specific definitions for the AT88SC1003.

Erase – A program operation that results in an EEPROM data bit being set to a logic “1” state. Outside the application zones, all erase operations are performed on 16-bit words. An erase operation performed on any bit within a word will execute an erase of the entire word. Inside an application zone, erase operations are controlled by the SV flag, EZ passwords and the EC2EN fuse. These operations are defined in the *Device Functional Operation* section of this data sheet (page 15).

Write – A program operation that results in an EEPROM bit or word being set to a logic “0” state. An unwritten bit is defined as erased, or set to a logic “1” state. Write operations in the AT88SC1003 may be performed on individual bits after security code validation. In Security Level 2, write operations also require that the P1, P2 or P3 bit within an application zone is set to “1”.

Program – An EEPROM function that activates internally timed, high-voltage circuitry and results in a data bit or word being set to either a logic “0” or “1” state.

Bit – A single data element set to either a logic “0” or “1” state. All bit addresses within the application zones (AZ1, AZ2, AZ3) may be written individually.

Byte – Eight consecutive data bits. A byte boundary will begin on an address that is evenly divisible by 8. The AT88SC1003 has no capability for byte write operations.

Word – Sixteen consecutive data bits. A word boundary will begin on an address that is evenly divisible by 16. The AT88SC1003 will allow words to be written to a “0” during personalization (Security Level 1). Erase operations will always operate on 16-bit words when applied to addresses outside the application zones.



Blown – In reference to AT88SC1003 internal EEPROM fuses, the blown state is a logic “0”.

Unblown – In reference to AT88SC1003 internal EEPROM fuses, the unblown state is a logic “1”.

Verification – AT88SC1003 operations are controlled by the state of several internal flags. The flags SV, E1, E2 and E3 are set after verification of an associated password (security code; EZ1, EZ2 and EZ3 respectively). Verification is accomplished by executing an INC/CMP operation, which correctly matches the password bit by bit as the CLK increments the address through the password memory addresses.

Definition of AT88SC1003 Internal Flags

Flag	Definition
SV	<p>Security Validation flag</p> <p>OPERATION: The SV flag is set by correctly matching the 16-bit security code bit by bit from address 80 through 95, as pin CLK increments the address counter. The security code matching operation must be followed immediately by a validation operation within the Security Code Attempts Counter (SCAC). This validation operation requires the user to find a bit in the SCAC, Addresses 96–99, that is a logic “1”. A write is performed followed by an erase. The AT88SC1003 will validate that the comparison was correct by outputting a logic “1”, and SV will be set. After the erase, all 16 bits in the SCAC will also be erased. The flag remains set until power to the card is turned off. If the comparison was in error or part of the validation was not performed correctly, the AT88SC1003 will output a logic “0” showing that SV has not been set. After four consecutive incorrect security code presentations, the card is permanently locked.</p> <p>FUNCTION: This flag is the master protection for the memory zones. See Tables 1 and 2.</p>
P1	<p>Application Zone 1 write flag</p> <p>OPERATION: If Bit 176 has been programmed to a logic “1”, this flag is set after Bit 176 has been addressed. The flag remains set until power to the device is turned off, even if this bit is written to “0” by a subsequent operation.</p> <p>FUNCTION: P1 and SV must both be set in order to enable a write command in Application Zone 1 (Security Mode 2).</p>
P2	<p>Application Zone 2 write flag</p> <p>OPERATION: If Bit 480 has been programmed to a logic “1”, this flag is set after Bit 480 has been addressed. The flag remains set until power to the device is turned off, even if this bit is written to “0” by a subsequent operation.</p> <p>FUNCTION: P2 and SV must both be set in order to enable the write command in Application Zone 2 (Security Mode 2).</p>
P3	<p>Application Zone 3 write flag</p> <p>OPERATION: If Bit 1024 has been programmed to a logic “1”, this flag is set after Bit 1024 has been addressed. The flag remains set until power to the device is turned off, even if this bit is written to “0” by a subsequent operation.</p> <p>FUNCTION: P3 and SV must both be set in order to enable a write command in Application Zone 3 (Security Mode 2).</p>
R1	<p>Application Zone 1 read flag</p> <p>OPERATION: If Bit 177 has been programmed to a logic “1”, this flag is set after Bit 177 has been addressed. The flag remains set until power to the device is turned off, even if this bit is written to “0” by a subsequent operation.</p> <p>FUNCTION: R1 or SV must be set to “1” in order to enable Application Zone 1 bits to be read.</p>
R2	<p>Application Zone 2 read flag</p> <p>OPERATION: If Bit 481 has been programmed to a logic “1”, this flag is set after Bit 481 has been addressed. The flag remains set until power to the device is turned off, even if this bit is written to “0” by a subsequent operation.</p> <p>FUNCTION: R2 or SV must be set to “1” in order to enable Application Zone 2 bits to be read.</p>
R3	<p>Application Zone 3 read flag</p> <p>OPERATION: If Bit 1025 has been programmed to a logic “1”, this flag is set after Bit 1025 has been addressed. The flag remains set until power to the device is turned off, even if this bit is written to “0” by a subsequent operation.</p> <p>FUNCTION: R3 or SV must be set to “1” in order to enable Application Zone 3 bits to be read.</p>

Definition of AT88SC1003 Internal Flags (Continued)

Flag	Definition
E1	<p>Application Zone 1 erase flag</p> <p>OPERATION: E1 is set when the Application Zone 1 erase code comparison is valid. This flag is reset when the address counter = 0.</p> <p>FUNCTION: Application Zone 1 (Bits 176–431) is erased when E1 is set and an erase is performed on Bit 480. This operation erases all bits in Application Zone 1 but does not affect the word containing Bit 480.</p>
E2	<p>Application Zone 2 erase flag with erase counter operation enabled. (EC2EN FUSE = “1”)</p> <p>OPERATION: This flag is set by correctly matching the Application Zone 2 erase code (EZ2) bit by bit as CLK increments the address counter. A validation operation must then be completed. This operation requires the user to find a bit in the Application Zone 2 erase counter (EC2), Addresses 768–895, that is a logic “1”. A write must then be performed, followed by an erase. The part will validate that the comparison was correct and Application Zone 2 will be erased. It is reset when the address counter = 0.</p> <p>FUNCTION: Application Zone 2 (Bits 480–735) is erased when E2 is set and an erase is performed after the validation operation in EC2 described above. This operation erases all bits in Application Zone 2.</p>
E2	<p>Application Zone 2 erase flag with erase counter operation disabled. (EC2EN FUSE = “0”)</p> <p>OPERATION: E2 is set when the Application Zone 2 erase code comparison is valid. This flag is reset when the address counter = 0.</p> <p>FUNCTION: Application Zone 2 (Bits 480–735) is erased when E2 is set and an erase is performed on Bit 768. This operation erases all bits in Application Zone 2 but does not affect the word containing Bit 768.</p>
E3	<p>Application Zone 3 erase flag</p> <p>OPERATION: E3 is set when the Application Zone 3 erase code comparison is valid. This flag is reset when the address counter = 0.</p> <p>FUNCTION: Application Zone 3 (Bits 1024–1535) is erased when E3 is set and an erase is performed on Bit 1584. This operation erases all bits in Application Zone 3.</p>

Definition of AT88SC1003 Passwords

Password	Definition
Security Code (SC) Bits 80–95 (16 bits)	This password is used to set the SV (Security Validation) flag and is used in determining what operations are allowed in each zone.
Erase Zone 1 (EZ1) Bits 432–479 (48 bits)	This password must be programmed during issuer personalization. It is used to erase Application Zone 1 in Security Level 2. Verification of EZ1 will set the internal flag E1 to “1”.
Erase Zone 2 (EZ2) Bits 736–767 (32 bits)	This password must be programmed during issuer personalization. It is used to erase Application Zone 2 in Security Level 2. Verification of EZ2 will set the internal flag E2 to “1”.
Erase Zone 3 (EZ3) Bits 1536–1583 (48 bits)	This password must be programmed during issuer personalization. It is used to erase Application Zone 3 in Security Level 2. Verification of EZ3 will set the internal flag E3 to “1”.

Definition of AT88SC1003 Fuses

Fab Zone Fuse

This fuse is used to control writes and erases of the fab zone. When the security code has been validated and both the issuer fuse and the fab zone fuse are unblown, writes and erases of the fab zone are allowed. Blowing the issuer fuse will also disable the fab zone fuse if it has not been blown previously.

Manufacturer Fuse

This fuse is used to control writes and erases of the manufacturer’s zone. When the security code has been validated and both the issuer fuse and the manufacturer fuse are unblown, writes and erases of the MFZ are allowed. Blowing the issuer fuse will also disable the manufacturer fuse if it has not been blown previously.

EC2EN Fuse

The EC2 enable fuse selects whether the EC2 zone is used to limit the number of AZ2 erases allowed in Security Mode 2. If the EC2EN fuse is “unblown,” then the AZ2 erases are limited to 128. If EC2EN fuse is “blown,” the AZ2 erases are unlimited. After the issuer fuse is blown, the state of EC2EN fuse is locked and cannot be changed.

Issuer Fuse

This fuse is used to personalize the AT88SC1003 for end customer use. It is an additional EEPROM bit that can be programmed to a logic “0”. This is its “blown” state. Security of the device when the issuer fuse is a logic “1” is described in Table 2 on page 12. The device is in Security Level 2 when the issuer fuse is blown. The device can also be placed in Security Level 2 by taking FUS pin low, independent of the state of the issuer fuse. Memory access rules of the device in Security Level 2 are described in Table 3 on page 13.

Table 2. Memory Access Rules During Personalization (Security Level 1)
 EC2EN = "X"; Issuer Fuse = "1" and FUS Pin = "1"

Zone	SV ⁽¹⁾	R1 ⁽²⁾	R2 ⁽³⁾	R3 ⁽⁴⁾	MF ⁽⁵⁾	FF ⁽⁶⁾	Read	Erase	Write	Compare
FZ	0	x	x	x	x	x	yes	no	no	no
	x	x	x	x	x	0	yes	no	no	no
	1	x	x	x	x	1	yes	yes	yes	no
IZ	0	x	x	x	x	x	yes	no	no	no
	1	x	x	x	x	x	yes	yes	yes	no
SC	0	x	x	x	x	x	no	no	no	yes
	1	x	x	x	x	x	yes	yes	yes	no
SCAC	0	x	x	x	x	x	yes	no	yes	no
	1	x	x	x	x	x	yes	yes	yes	no
CPZ	0	x	x	x	x	x	yes	no	no	no
	1	x	x	x	x	x	yes	yes	yes	no
AZ1	0	0	x	x	x	x	no	no	no	no
	0	1	x	x	x	x	yes	no	no	no
	1	x	x	x	x	x	yes	yes	yes	no
EZ1	0	x	x	x	x	x	no	no	no	no
	1	x	x	x	x	x	yes	yes	yes	no
AZ2	0	x	0	x	x	x	no	no	no	no
	0	x	1	x	x	x	yes	no	no	no
	1	x	x	x	x	x	yes	yes	yes	no
EZ2	0	x	x	x	x	x	no	no	no	no
	1	x	x	x	x	x	yes	yes	yes	no
EC2	0	x	x	x	x	x	yes	no	yes	no
	1	x	x	x	x	x	yes	yes	yes	no
MTZ	x	x	x	x	x	x	yes	yes	yes	no
MFZ	0	x	x	x	x	x	yes	no	no	no
	x	x	x	x	0	x	yes	no	no	no
	1	x	x	x	1	x	yes	yes	yes	no
AZ3	0	x	x	0	x	x	no	no	no	no
	0	x	x	1	x	x	yes	no	no	no
	1	x	x	x	x	x	yes	yes	yes	no
EZ3	0	x	x	x	x	x	no	no	no	no
	1	x	x	x	x	x	yes	yes	yes	no

- Notes:
- SV = "1" after validation of the security code
 - 2nd bit of the Application Zone 1 (Bit 177)
 - 2nd bit of the Application Zone 2 (Bit 481)
 - 2nd bit of the Application Zone 3 (Bit 1025)
 - Manufacturer fuse = "0" when blown.
 - Fab zone fuse = "0" when blown.

Table 3. Memory Access Rules After Personalization (Security Level 2)

Manufacturer Fuse = "X"; EC2EN Fuse = "1" or "0"; Issuer Fuse = "0" or FUS Pin = "0"





Zone	SV ⁽¹⁾	P1 ⁽²⁾	R1 ⁽³⁾	P2 ⁽⁴⁾	R2 ⁽⁵⁾	P3 ⁽⁶⁾	R3 ⁽⁷⁾	E1 ⁽⁸⁾	E2 ⁽⁹⁾	E3 ⁽¹⁰⁾	Read	Erase	Write	Compare
FZ	x	x	x	x	x	x	x	x	x	x	yes	no	no	no
IZ	x	x	x	x	x	x	x	x	x	x	yes	no	no	no
SC	0	x	x	x	x	x	x	x	x	x	no	no	no	yes
	1	x	x	x	x	x	x	x	x	x	no	yes	yes	no
SCAC	0	x	x	x	x	x	x	x	x	x	yes	no	yes	no
	1	x	x	x	x	x	x	x	x	x	yes	yes	yes	no
CPZ	0	x	x	x	x	x	x	x	x	x	yes	no	no	no
	1	x	x	x	x	x	x	x	x	x	yes	yes	yes	no
AZ1	0	x	0	x	x	x	x	x	x	x	no	no	no	no
	0	x	1	x	x	x	x	x	x	x	yes	no	no	no
	1	0	x	x	x	x	x	0	x	x	yes	no	no	no
	1	0	x	x	x	x	x	1	x	x	yes	yes	no	no
	1	1	x	x	x	x	x	0	x	x	yes	no	yes	no
	1	1	x	x	x	x	x	1	x	x	yes	yes	yes	no
EZ1	x	x	x	x	x	x	x	x	x	x	no	no	no	yes
AZ2	0	x	x	x	0	x	x	x	x	x	no	no	no	no
	0	x	x	x	1	x	x	x	x	x	yes	no	no	no
	1	x	x	0	x	x	x	x	0	x	yes	no	no	no
	1	x	x	0	x	x	x	x	1	x	yes	yes	no	no
	1	x	x	1	x	x	x	x	0	x	yes	no	yes	no
	1	x	x	1	x	x	x	x	1	x	yes	yes	yes	no
EZ2	x	x	x	x	x	x	x	x	x	x	no	no	no	yes
EC2	x	x	x	x	x	x	x	x	x	x	yes	no	yes	no
MTZ	x	x	x	x	x	x	x	x	x	x	yes	yes	yes	no
MFZ	x	x	x	x	x	x	x	x	x	x	yes	no	no	no
AZ3	0	x	x	x	x	x	0	x	x	x	no	no	no	no
	0	x	x	x	x	x	1	x	x	x	yes	no	no	no
	1	x	x	x	x	0	x	x	x	0	yes	no	no	no
	1	x	x	x	x	0	x	x	x	1	yes	yes	no	no
	1	x	x	x	x	1	x	x	x	0	yes	no	yes	no
	1	x	x	x	x	1	x	x	x	1	yes	yes	yes	no
EZ3	x	x	x	x	x	x	x	x	x	x	no	no	no	yes

- Notes:
- SV = "1" after validation of the security code
 - 1st bit of the Application Zone 1 (Bit 176)
 - 2nd bit of the Application Zone 1 (Bit 177)
 - 1st bit of the Application Zone 2 (Bit 480)
 - 2nd bit of the Application Zone 2 (Bit 481)
 - 1st bit of the Application Zone 3 (Bit 1024)
 - 2nd bit of the Application Zone 3 (Bit 1025)
 - E1 = "1" after a valid presentation of EZ1.
 - E2 = "1" after a valid presentation of EZ2.
 - E3 = "1" after a valid presentation of EZ3.



Micro Operations

The AT88SC1003 circuit micro operation modes are selected by the input logic levels on the control pins PGM, RST and CLK and by the internal address. Timing for these operations is specified in the *AC Characteristics* section (page 20).

Operation	PGM	RST	CLK	Definition
RESET	X		0	The internal address is reset to "0". After the falling edge of RST, the first bit of the fabrication zone (Bit 0) will be driven on the I/O contact. All erase flags (E1, E2, E3) are reset.
INC/READ	0	0		The address is incremented on the falling edge of CLK. If read operations are enabled, the addressed bit will be driven on the I/O contact after the falling edge of CLK. This data is valid until the next falling edge of CLK, except for the bits immediately preceding the security code and erase keys. For these bits, the data is valid only while CLK is low. When CLK goes high, the I/O line will be disabled (high impedance). This will allow data to be set up on the I/O line before comparing the first bit of each code. When read operations are disabled, the I/O will be disabled and pulled to a high state by the external system pullup resistor.
INC/CMP	0	0		The INC/CMP operation will compare the value of the data driven by the system host on the I/O pin, to the value of the bit already written to the EEPROM memory at that address location. This process is used during validation of the AT88SC1003 security code and passwords. The data must be stable on the I/O pin before the falling edge of CLK, when the data will be latched internally. Comparison occurs on the next falling edge of CLK. The address is incremented on the falling edge of CLK.
ERASE/WRITE	1	0		The I/O pin must be driven to a "1" for an erase and to a "0" for a write operation before the rising edge of CLK. CLK must be held high for at least 2 ms. After the falling edge of CLK, the data written to the EEPROM will be driven by the AT88SC1003 on the I/O pin.
STANDBY	0	1	X	The device is placed in standby mode when FUS = "0" and RST = "1". The address counter will not increment when RST is high.

Note: The two instructions INC/READ and INC/CMP share the same control signal states. The circuit will distinguish between the two instructions by testing the internal address counter. (CMP can only be done with the addresses corresponding to the security code or to the erase keys.) The internal address counter counts up to 1599. An additional CLK pulse resets the address to "0".

Device Functional Operation

Function	Functional Operation Sequence
POR	<p>OPERATION: POR (power on reset) is initiated as the device power supply ramps from 0V up to a valid operating voltage.</p> <p>FUNCTION: POR resets all flags, and the address is reset to "0".</p>
RESET	<p>OPERATION: With CLK low, a falling edge on the RST pin will reset the address counter to address 0.</p> <p>FUNCTION: The address is reset to "0", and the first bit of the memory is driven by the AT88SC1003 on I/O after a reset. E1, E2 and E3 are reset when the address is reset to "0". The reset operation has no effect on any of the other flags (SV, P1, P2, P3, R1, R2, R3).</p>
ADDRESSING	<p>OPERATION: Addressing is handled by an internal address counter. The address is incremented on the falling edge of CLK. Reset must be low while incrementing the address. The falling edge of reset clears the counter to address "0".</p> <p>FUNCTION: Addressing of the AT88SC1003 is sequential. Specific bit addresses may be reached by completing a reset, then clocking the device (INC/READ) until the desired address is reached. The AT88SC1003 will determine which operations are allowed at specific address locations. These operations are specified in Tables 1 and 2.</p> <p>EXAMPLE: To address the Issuer Zone (IZ), execute a reset operation, then clock the device 16 times. The device now outputs the first bit of the IZ. After the address counter counts up to 1599, the next CLK pulse resets the address to "0".</p>
READ	<p>OPERATION: RST and PGM pins must be low. If a read operation is allowed, the state of the memory bit being addressed is output on the I/O pin. The I/O buffer is an open drain and the output of a logic "0", which therefore causes the device to pull the pin to ground. The output of a logic "1" causes the device to place the pin in a high impedance state. Therefore, in order to sense a logic "1", an external pullup must be placed between the I/O pin and VCC. The address counter is incremented on the falling edge of CLK.</p> <p>FUNCTION: NON-APPLICATION ZONES: As the address is incremented, the contents of the memory are read out on the I/O pin. The read operation is inhibited for addresses where security prevents a read operation (see Tables 1 and 2). APPLICATION ZONES: The application zones can be read when: SV = "1" or R1(AZ1) / R2(AZ2) / R3(AZ3) = "1"</p>
FUSE READ	<p>OPERATION: When the FUS pin is high, the state of the various fuses can be read when addressing the corresponding bits in the memory.</p> <p>FUNCTION: To verify the state of the fuses.</p>

Device Functional Operation (Continued)

Function	Functional Operation Sequence
WRITE	<p>A write operation sets the bit(s) to a logic "0".</p> <p>OPERATION: CLK = "0" PGM "0" → "1" (I/O switches to an input) I/O = "0" (Input = "0" for write operation) CLK "0" → "1" (rising edge of CLK starts the write operation) PGM "1" → "0" I/O "0" → "Z" (high impedance) Wait Tchp (see <i>AC Electrical Characteristics</i>) CLK "1" → "0" (falling edge of CLK ends the write operation) Note: The falling edge of CLK that ends the write operation does not increment the address counter.</p> <p>FUNCTION: NON-APPLICATION ZONES: The write operation is inhibited for addresses where security prevents a write operation (see Tables 1 and 2). APPLICATION ZONES: The application zones can be written when: Security Level 1: SV = "1" Security Level 2: SV = "1" and P1(AZ1)/P2(AZ2)/P3(AZ3) = "1"</p>
ERASE Operation Sequence	<p>CLK = "0" PGM "0" → "1" (I/O switches to an input) I/O = "1" (input = "1" for erase operation) CLK "0" → "1" (rising edge of CLK starts the erase operation) PGM "1" → "0" I/O "0" → "Z" (high impedance) Wait Tchp (See <i>AC Electrical Characteristics</i>) CLK "1" → "0" (falling edge of CLK ends the erase operation) Note: The falling edge of CLK that ends the erase operation does not increment the address counter.</p>
ERASE (Non-application Zones)	<p>An erase operation sets the bits to logic "1". The EEPROM memory is organized into 16-bit words. Although erases are performed on single bits, the erase operation clears an entire word in the memory (except for the Application Zones AZ1, AZ2 and AZ3 in Security Level 2). Therefore, performing an erase on any bit in the word will clear <i>all</i> 16 bits of that word to logic "1".</p> <p>OPERATION: Perform "Erase Operation Sequence" as specified above.</p> <p>FUNCTION: The erase operation is inhibited for addresses where security prevents an erase operation (see Tables 1 and 2).</p>
ERASE AZ1, AZ2 and AZ3 Security Mode 1	<p>Security Level 1: (Issuer fuse = "1" and FUS pin = "1") Application Zones 1, 2 and 3 can be erased when: SV = "1"</p> <p>OPERATION: Increment address counter to any bit within AZ1, AZ2 or AZ3. Perform "Erase Operation Sequence" as specified above.</p> <p>FUNCTION: This operation will erase the entire application zone.</p>

Device Functional Operation (Continued)

Function	Functional Operation Sequence
ERASE AZ1 and AZ3 Security Mode 2	Security Level 2 (Issuer Fuse = "0" or FUS pin = "0") SV = "1" and E1 (AZ1)/E3 (AZ3) = "1" OPERATION: Increment address counter to the first bit of the application zone erase key (EZ1 = Bit 432, EZ3 = Bit 1536). Execute 48 INC/CMP operations, correctly verifying each bit of the 48-bit erase key. Increment the address counter to the next bit (Bit 480 for AZ1, Bit 1584 for AZ3). Perform "Erase Operation Sequence" as specified above. FUNCTION: This operation will erase the entire application zone.
ERASE AZ2 Security Mode 2 EC2 Mode Enabled	Security Mode 2: (EC2EN = "1" and Issuer Fuse = "0" or FUS pin = "0") EC2 mode is enabled. Erase operations within Zone 2 limited to 128. OPERATION: Increment address counter to the first bit of the application zone erase key (EZ2 = Bit 736). Execute 32 INC/CMP operations, correctly verifying each bit of the 32-bit erase key. Increment the address counter through the Application Zone 2 erase counter (EC2 = Bits 768–895) until a bit is found that is set to "1". Perform a write operation on this bit (this write will not increment the address counter). Perform an erase operation on the same bit. FUNCTION: This operation will erase the entire application zone.
ERASE AZ2 Security Mode 2 EC2 Mode Disabled	Security Mode 2 (EC2EN = "0" and Issuer Fuse = "0" or FUS pin = "0") EC2 mode is disabled. Unlimited erase operations in Zone 2. OPERATION: Increment address counter to the first bit of the application zone erase key (EZ2 = Bit 736). Execute 32 INC/CMP operations, correctly verifying each bit of the 32-bit erase key. Increment the address counter to the next bit (Bit 768). Perform "Erase Operation Sequence" as specified above. FUNCTION: This operation will erase the entire application zone.
Blowing Fab Zone Fuse	Fab zone fuse must be blown before issuer fuse is blown. Set address between Addresses 1012 and 1015. SV must be set. The FUS pin can be either a "0" or a "1". RST pin = "0" Perform a write operation. Fab zone fuse will be at a logic "0" state.

Device Functional Operation (Continued)

Function	Functional Operation Sequence
Blowing Manufacturer Fuse	Set address counter between Address 1016 and 1019. SV must be set. The FUS pin can be either a “0” or a “1”. RST pin = “0” Perform a write operation. Manufacturer fuse will be at a logic “0” state.
Blowing EC2EN Fuse	EC2EN fuse must be blown before issuer fuse is blown. SV must be set. Set address between Address 1020 and 1023. FUS pin = “1” RST pin = “0” Perform a write operation. EC2EN fuse will be at a logic “0” state.
Blowing Issuer Fuse	Set address counter between Address 992 and 1007. SV must be set. The FUS pin can be either a “0” or a “1”. RST pin = “0” Perform a write operation. Issuer fuse will be at a logic “0” state.

Electrical Characteristics

Absolute Maximum Ratings*

Operating Temperature	-55°C to +100°C
Storage Temperature.....	-65°C to +100°C
Voltage on Any Pin with Respect to Ground.....	-0.3V to $V_{CC} + 0.7V$
Maximum Operating Voltage	6.25V
DC Output Current.....	5.0 mA

*NOTICE: Stresses beyond those listed under “Absolute Maximum Ratings” may cause permanent damage to the device. This is a stress rating only and functional operation of the device at these or any other conditions beyond those indicated in the operational sections of this specification is not implied. Exposure to absolute maximum rating conditions for extended periods may affect device reliability.

DC Characteristics

Applicable over recommended operating range from: $V_{CC} = 4.5V$ to $5.5V$ and $T_A = -25^\circ C$ to $+85^\circ C$ (unless otherwise noted).

Symbol	Parameter	Test Condition	Min	Typ	Max	Unit
I_{CC}	Supply Current on V_{CC} during Read ($T_A = +25^\circ C$)		-	-	2	mA
I_{CCP}	Supply Current on V_{CC} during Program ($T_A = +25^\circ C$)		-	-	5	mA
I_{SB}	Standby Current on V_{CC} RST @ V_{CC} FUS, CLK, PGM @ GND. $I_{OL} = 0 \mu A$. $F_{CLK} = 0$ kHz)		-	-	50	μA
V_{IL}	Input Low Level		-0.3	-	$V_{CC} \times 0.3$	V
V_{IH}	Input High Level		$V_{CC} \times 0.7$	-	$V_{CC} + 0.3$	V
V_{OL}	Output Low Level ($I_{OL} = 1$ mA)		-	-	0.4	V
I_{LI}	Input Leakage Current		-	-	100	μA
I_{LO}	I/O Leakage Current ($V_{OH} = V_{CC}$ open drain)		-	-	20	μA

AC Characteristics

$T_A = -25^{\circ}\text{C}$ to $+85^{\circ}\text{C}$, $V_{CC} = 5\text{V} \pm 10\%$, $\text{GND} = 0\text{V}$ (unless otherwise noted)

Characteristics	Symbol	Min	Typ	Max	Unit
Clock Cycle Time	t_{CLK}	3.3	–	–	μs
RST Hold Time	t_{RH}	0.1	–	–	μs
Data Valid Reset to Address “0”	t_{DVR}	–	–	2.0	μs
CLK Pulse Width (High)	t_{CH}	0.2	–	–	μs
CLK Pulse Width (Low)	t_{CL}	0.2	–	–	μs
Data Access	t_{DV}	–	–	2.0	μs
Data Hold	t_{OH}	0	–	–	μs
Data In Setup (CMP Instruction)	t_{SC}	0	–	–	ns
Data In Hold (CMP Instruction)	t_{HC}	0.2	–	–	μs
CLK Pulse Width (High in Programming)	t_{CHP}	2.0	–	–	ms
Data In Setup	t_{DS}	0.2	–	–	μs
Data In Hold	t_{DH}	0	–	–	μs
PGM Setup	t_{SPR}	2.2	–	–	μs
PGM Hold	t_{HPR}	0.2	–	–	μs

Conditions of Dynamic Tests

The circuit has an output with open drain. An external resistor is necessary between V_{CC} and I/O in order to load the output.

Pulse Levels of the Input	V_{SS} to V_{CC}
Reference Levels in Input	$V_{CC} \times 0.3$ and $V_{CC} \times 0.7$
Reference Levels in Output	1.5V
Rising and Falling Time of Signals	5 ns

Figure 3. AC Load Circuit

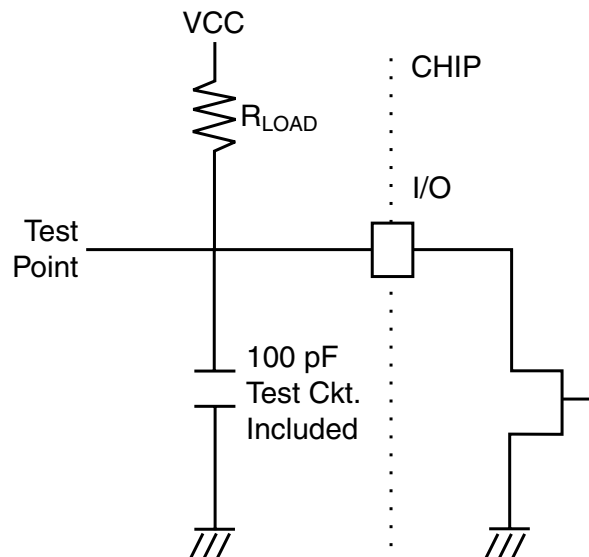

Timing Diagrams

Figure 4. Reset

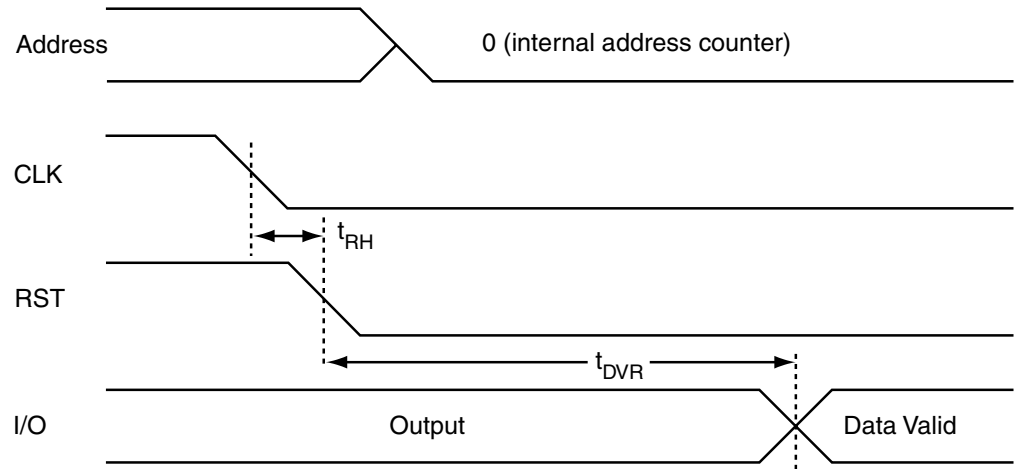

Note: CLK should be low on the falling edge of RST. CLK may remain low while RST is pulsed.

Figure 5. Inc/Read

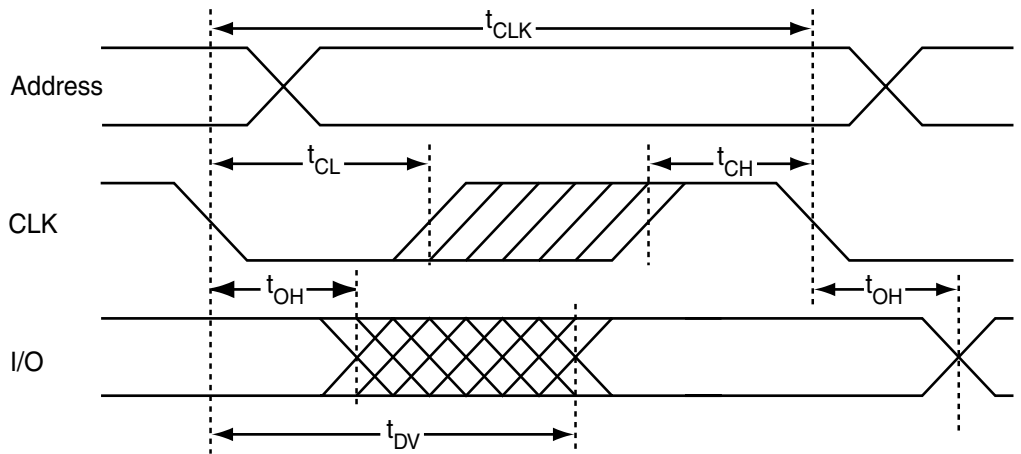

Note: PGM and RST must both be low during a read cycle. I/O should not be driven (except by the external pullup resistor).

Figure 6. Erase/Write

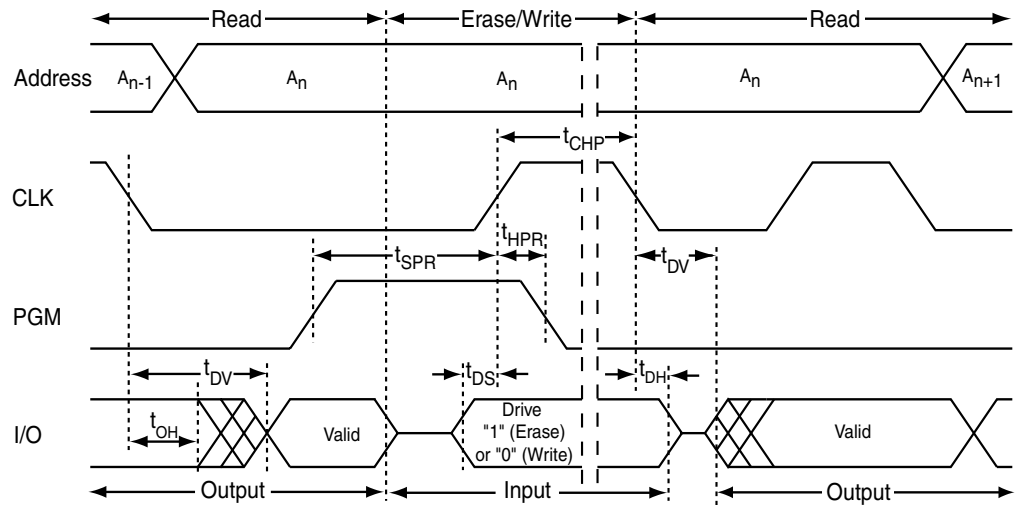

Note: During any erase or write operation, PGM must fall before the falling edge of CLK at the end of t_{CHP} (recommend a minimum setup time of 1 usec). After the rising edge of PGM to initiate the erase/write operation, delay at least t_{DV} (2 usec) before driving data on the I/O contact.

Figure 7. Compare

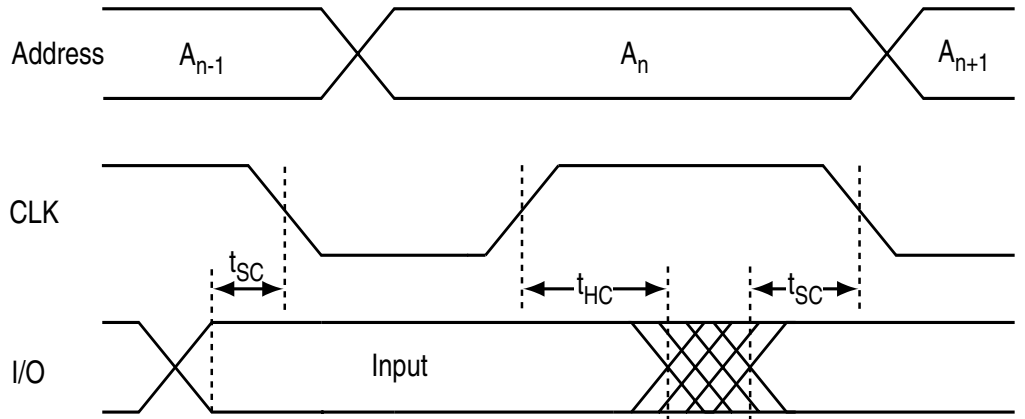

Note: Input data is latched on the falling edge of CLK. Comparison occurs on the next falling edge of CLK. The address counter is incremented on the falling edge of CLK.

Figure 8. INC/CMP (before code presentation)

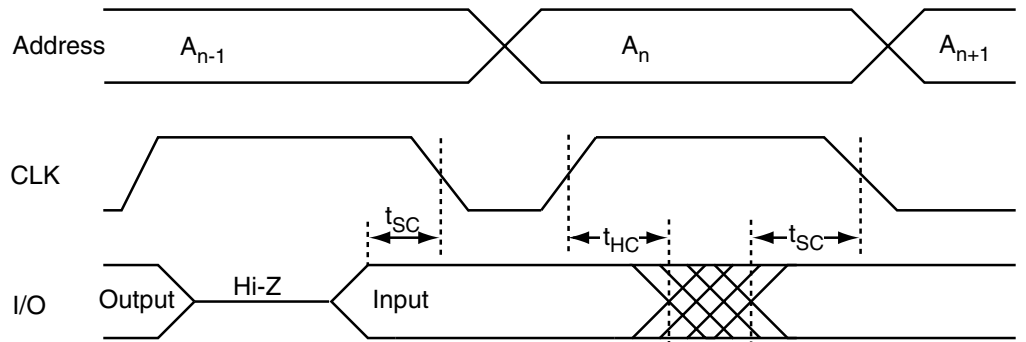

Note: After the rising edge of CLK on the address immediately preceding the security code or erase keys, the I/O will be disabled (Hi-Z). This allows the input data to be set up before comparing the first bit of each code.

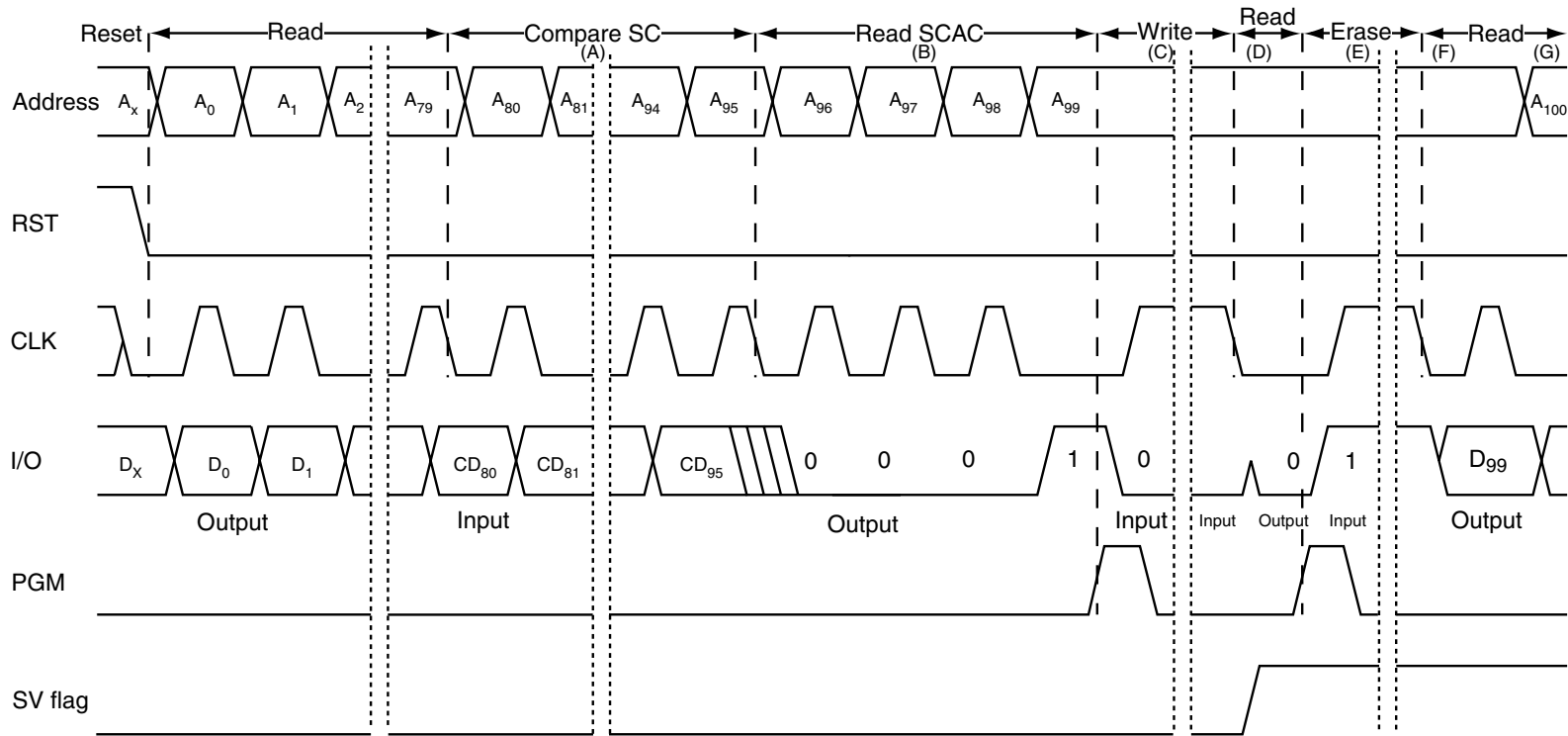

Figure 9. Security Code Validation

Note: A_n = Address, D_n = Read data (output), CD_n = Compare data (input)

Security Level 2 (issuer fuse blown).

A = Compare sequence of the security code.

B = This diagram shows an example in which the first three bits of the Security Code Attempts Counter (96–98) are previously set to “0”. Bit 99 in this example is a “1”, so the write/erase sequence is begun with that bit.

C = Write operation of a “0” over the existing “1”.

D = The AT88SC1003 will output a “0” following the write operation. If the comparison is successful, the SV flag is set on the falling edge of CLK and the SCAC zone can be erased.

E = Erase operation.

F = The AT88SC1002 will output a “1” following the erase operation if the security code verification is successful. If invalid, the device will output a “0”.

G = On the falling edge of CLK, the address is incremented and the state of the next bit is driven on the I/O pin.

Figure 10. Erase Operation Application Zone 1 (AZ1)

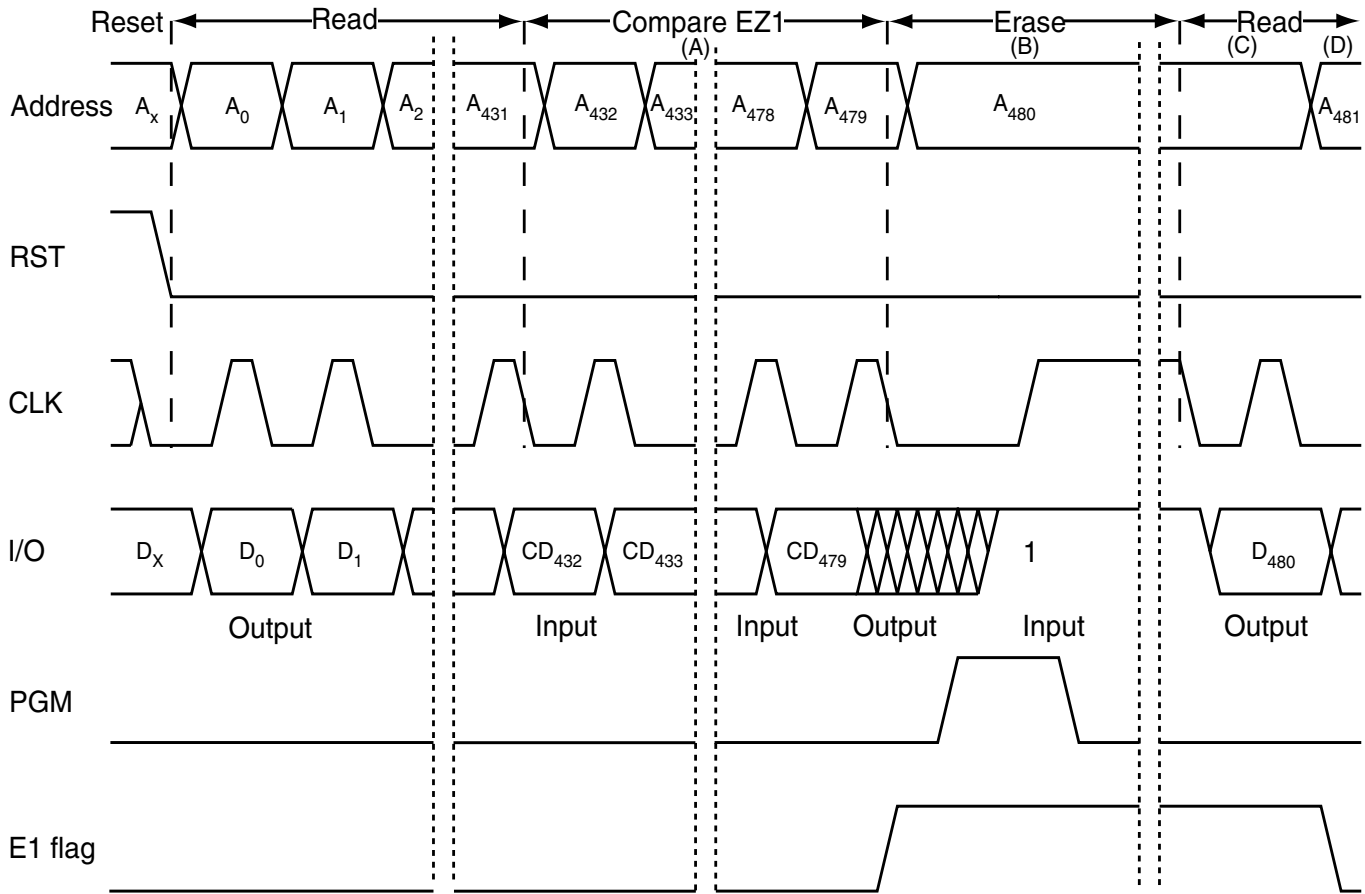

Note: A_n = Internal Address, D_n = Read data (output), CD_n = Compare data (input).
 This diagram illustrates the protocol for setting the E1 flag in Security Level 2 (issuer fuse blown). Erase operations in Security Level 1 within Application Zone 1 do not require setting of the E1 flag. In Security Level 1, an erase operation on any bit in Application Zone 1 will erase the entire zone.
 A = Compare sequences of EZ1. If the comparison is valid, the EZ1 flag is set to "1", enabling erasure of AZ1.
 B = If E1 is set to "1", an erase operation on Bit 480 will erase Bits 176–431 (AZ1).
 C = After the falling edge of CLK, the device will drive the I/O contact to the logic state of the existing data in Bit 480. The state of this bit is not affected by the AZ1 erase operation.
 D = After the falling edge of CLK, the address is incremented and the state of the next bit is driven on the I/O contact.

Figure 11. Erase Operation Application Zone 2 (AZ2) EC2 Function Disabled

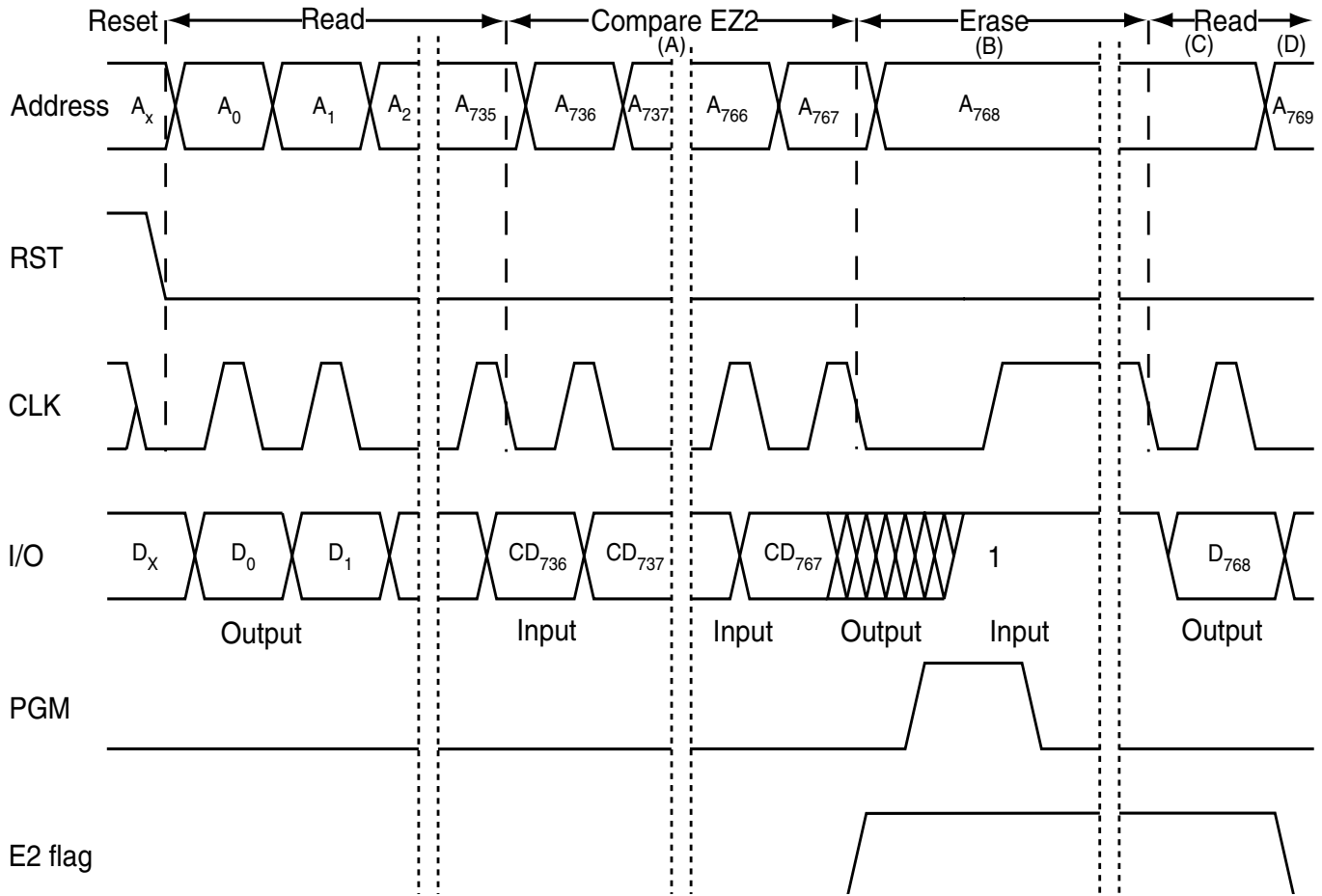

Note: A_n = Internal Address, D_n = Read data (output), CD_n = Compare data (input).
 This diagram illustrates the protocol for setting the E2 flag in Security Level 2 (issuer fuse blown). Erase operations in Security Level 1 within Application Zone 2 do not require setting of the E2 flag. In Security Level 1, an erase operation on any bit in Application Zone 2 will erase the entire zone. EC2EN Fuse - "0" (disabled).
 A = Compare sequence of EZ2. If the comparison is valid, the E2Z flag is set to "1", enabling erasure of AZ2.
 B = If E2 is set to "1", an erase operation on Bit 768 will erase Bits 480–735 (AZ2).
 C = After the falling edge of CLK, the device will drive the I/O contact to the logic state of the existing data in Bit 768. The state of this bit is not affected by the AZ2 erase operation.
 D = After the falling edge of CLK, the address is incremented and the state of the next bit is driven on the I/O contact.

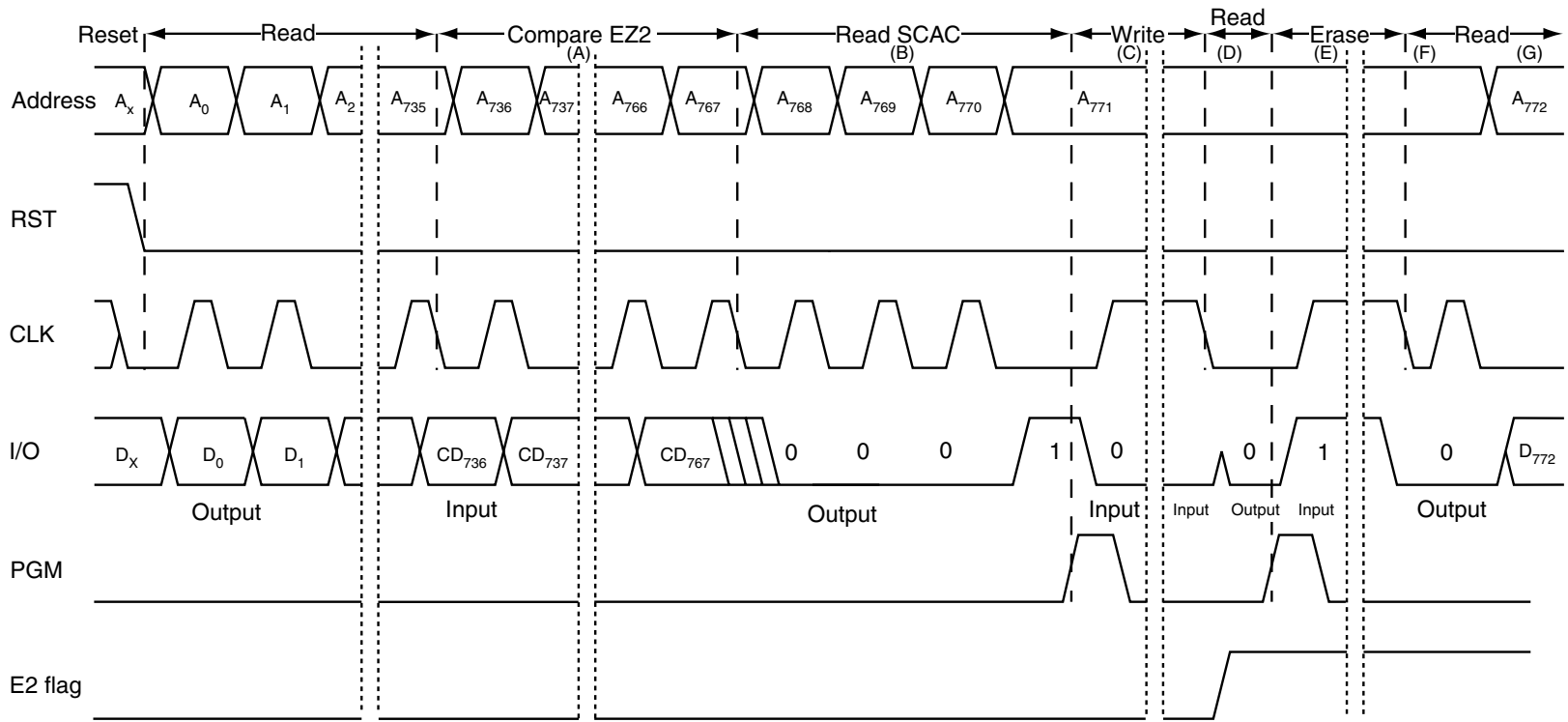

Note: A_n = Address, D_n = Read data (output), CD_n = Compare data (input).

EC2EN fuse = "1" (enabled); Security Level 2 (issuer fuse blown).

A = Compare sequence of the erase key (EZ2).

B = This diagram shows an example in which the first three bits of the EC2 Erase Counter (Bits 768–770) are previously set to "0". The write/erase operation should be performed on the first bit in EC2 that is found to be a "1". Bit 771 in this example is a "1", so the write/erase sequence is begun with that bit.

C = Write operation of a "0" over the existing "1".

D = The AT88SC1003 will output a "0" following the write operation. If the comparison is successful, the E2 flag is set and the AZ2 zone can be erased.

E = Erase operation.

F = The AT88SC1002 will output a "0" following the erase operation regardless of the success of the compare operation.

G = On the falling edge of CLK, the address is incremented and the state of the next bit is driven on the I/O pin.

Figure 12. Erase Operation Application Zone 2 (AZ2) EC2 Function Enabled

Figure 13. Erase Operation Application Zone 3 (AZ3)

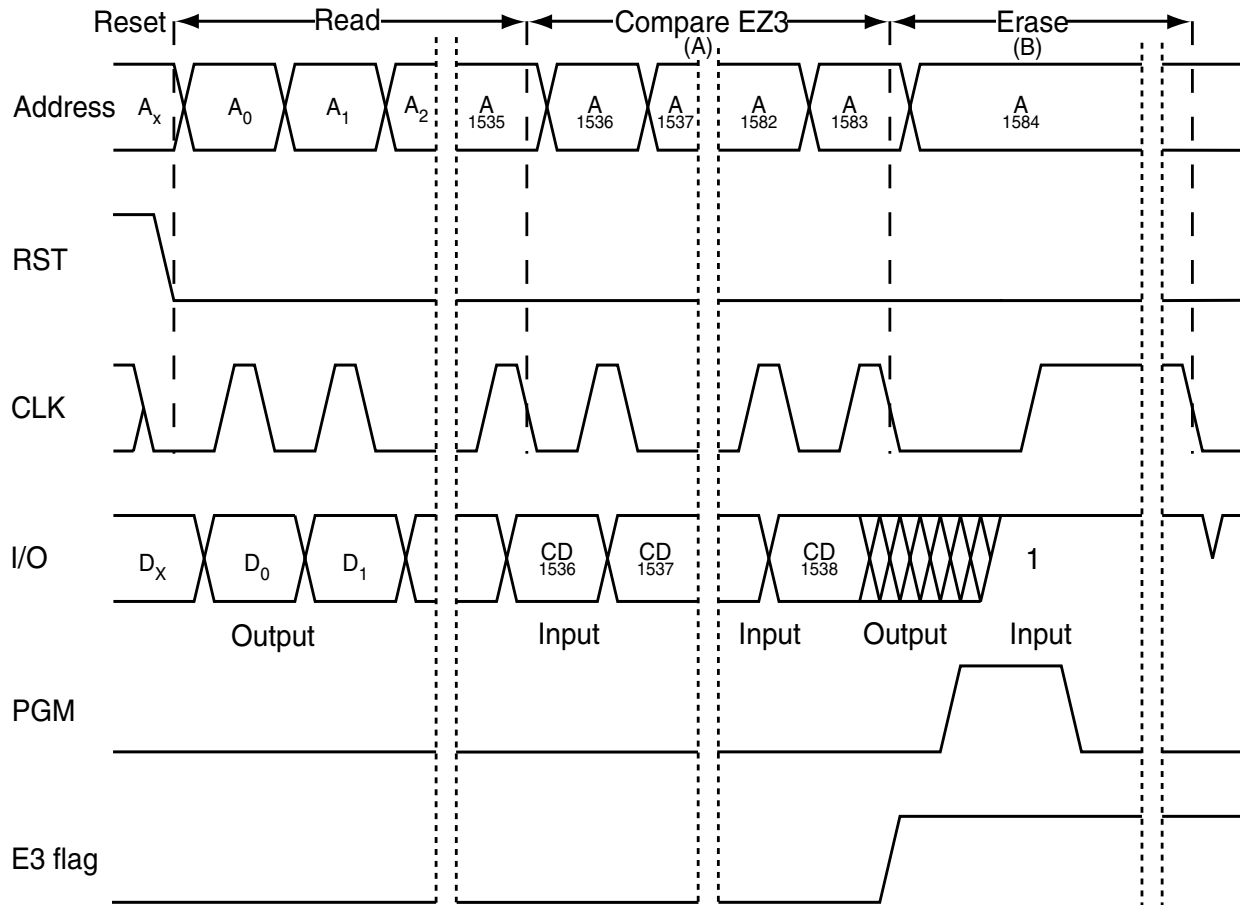

Note: A_n = Internal Address, D_n = Read data (output), CD_n = Compare data (input).
 This diagram illustrates the protocol for setting the E3 flag in Security Level 2 (issuer fuse blown). Erase operations in Security Level 1 within Application Zone 3 do not require setting of the E3 flag. In Security Level 1, an erase operation on any bit in Application Zone 3 will erase the entire zone.
 A = Compare sequence of EZ3. If the comparison is valid, the EZ3 flag is set to "1", enabling erasure of AZ3.
 B = If E3 is set to "1", an erase operation on Bit 1584 will erase Bits 1024–1535 (AZ3). After the falling edge of CLK, the address is incremented. The E3 flag will be reset to "0" when the reset function is executed, or when the address is incremented beyond Address 1599.

Ordering Information

Ordering Code	Package	Voltage Range	Temperature Range
AT88SC1003-09CT-00	M4 – C Module	4.5V to 5.5V	–25C to +85C
AT88SC1003-09DT-00	M4 – D Module		
AT88SC1003-09ET-00	M2 – E Module		
AT88SC1003-09NT-00	M2 – N Module		
AT88SC1003-09PT-00	M2 – P Module		

Package Type	
M4 – C Module	M4 ISO 7816 Smart Card Module
M4 – D Module	M4 ISO 7816 Smart Card Module with Atmel Logo
M2 – E Module	M2 ISO 7816 Smart Card Module
M2 – N Module	M2 ISO 7816 Smart Card Module
M2 – P Module	M2 ISO 7816 Smart Card Module with Atmel Logo

Note: Formal drawings may be obtained from an Atmel Sales Office.

Packaging Information

Ordering Code: 09NT

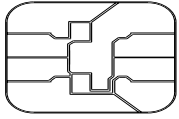

Module Size: **M2**
 Dimension*: 12.6 x 11.4 [mm]
 Glob Top: Square - 8.8 x 8.8 [mm]
 Thickness: 0.58 [mm]
 Pitch: 14.25 mm

Ordering Code: 09CT

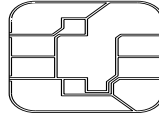

Module Size: **M4**
 Dimension*: 12.6 x 12.6 [mm]
 Glob Top: Square - 9.0 x 9.0 [mm]
 Thickness: 0.58 [mm]
 Pitch: 14.25 mm

Ordering Code: 09PT

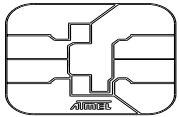

Module Size: **M2**
 Dimension*: 12.6 x 11.4 [mm]
 Glob Top: Square - 8.8 x 8.8 [mm]
 Thickness: 0.58 [mm]
 Pitch: 14.25 mm

Ordering Code: 09DT

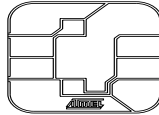

Module Size: **M4**
 Dimension*: 12.6 x 12.6 [mm]
 Glob Top: Square - 9.0 x 9.0 [mm]
 Thickness: 0.58 [mm]
 Pitch: 14.25 mm

Ordering Code: 09ET

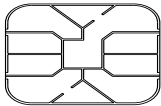

Module Size: **M2**
 Dimension*: 12.6 x 11.4 [mm]
 Glob Top: Round - \varnothing 8.0 [mm]
 Thickness: 0.58 [mm]
 Pitch: 14.25 mm

Note: The module dimensions listed refer to the dimensions of the exposed metal contact area. The actual dimensions of the module after excise or punching from the carrier tape are generally 0.4 mm greater in both directions (i.e., a punched M2 module will yield 13.0 x 11.8 mm).

Note: 1. The module dimensions listed refer to the dimensions of the exposed metal contact area. The actual dimensions of the module after excise or punching from the carrier tape are generally 0.4 mm greater in both directions (i.e., a punched M2 module will yield 13.0 x 11.8 mm).



Atmel Headquarters

Corporate Headquarters

2325 Orchard Parkway
San Jose, CA 95131
TEL 1(408) 441-0311
FAX 1(408) 487-2600

Europe

Atmel Sarl
Route des Arsenaux 41
Case Postale 80
CH-1705 Fribourg
Switzerland
TEL (41) 26-426-5555
FAX (41) 26-426-5500

Asia

Room 1219
Chinachem Golden Plaza
77 Mody Road Tsimhatsui
East Kowloon
Hong Kong
TEL (852) 2721-9778
FAX (852) 2722-1369

Japan

9F, Tonetsu Shinkawa Bldg.
1-24-8 Shinkawa
Chuo-ku, Tokyo 104-0033
Japan
TEL (81) 3-3523-3551
FAX (81) 3-3523-7581

Atmel Operations

Memory

2325 Orchard Parkway
San Jose, CA 95131
TEL 1(408) 441-0311
FAX 1(408) 436-4314

Microcontrollers

2325 Orchard Parkway
San Jose, CA 95131
TEL 1(408) 441-0311
FAX 1(408) 436-4314

La Chantrerie
BP 70602
44306 Nantes Cedex 3, France
TEL (33) 2-40-18-18-18
FAX (33) 2-40-18-19-60

ASIC/ASSP/Smart Cards

Zone Industrielle
13106 Rousset Cedex, France
TEL (33) 4-42-53-60-00
FAX (33) 4-42-53-60-01

1150 East Cheyenne Mtn. Blvd.
Colorado Springs, CO 80906
TEL 1(719) 576-3300
FAX 1(719) 540-1759

Scottish Enterprise Technology Park
Maxwell Building
East Kilbride G75 0QR, Scotland
TEL (44) 1355-803-000
FAX (44) 1355-242-743

RF/Automotive

Theresienstrasse 2
Postfach 3535
74025 Heilbronn, Germany
TEL (49) 71-31-67-0
FAX (49) 71-31-67-2340

1150 East Cheyenne Mtn. Blvd.
Colorado Springs, CO 80906
TEL 1(719) 576-3300
FAX 1(719) 540-1759

Biometrics/Imaging/Hi-Rel MPU/ High Speed Converters/RF Datacom

Avenue de Rochepleine
BP 123
38521 Saint-Egreve Cedex, France
TEL (33) 4-76-58-30-00
FAX (33) 4-76-58-34-80

e-mail

literature@atmel.com

Web Site

<http://www.atmel.com>

© Atmel Corporation 2002.

Atmel Corporation makes no warranty for the use of its products, other than those expressly contained in the Company's standard warranty which is detailed in Atmel's Terms and Conditions located on the Company's web site. The Company assumes no responsibility for any errors which may appear in this document, reserves the right to change devices or specifications detailed herein at any time without notice, and does not make any commitment to update the information contained herein. No licenses to patents or other intellectual property of Atmel are granted by the Company in connection with the sale of Atmel products, expressly or by implication. Atmel's products are not authorized for use as critical components in life support devices or systems.

ATMEL® is the registered trademark of Atmel.

Other terms and product names may be the trademarks of others.



Printed on recycled paper.

2035A-SMEM-4/02