

Features

General

- High-performance, Low-power AVR[®] (AVR2 Core) Enhanced RISC Architecture
 - 120 Powerful Instructions (Most Executed in a Single Clock Cycle)
- Low-power Idle and Power-down Modes
- Bond Pad Locations Conforming to ISO 7816-2
- ESD Protection to $\pm 6000V$
- Operating Ranges: from 2.7V to 3.3V and 4.5V to 5.5V
- Compliant with GSM, 3GPP and EMV 2000 Specifications; PC Industry Compatible
- Available in Wafers, Modules and Industry-standard Packages

Memory

- 32K Bytes of Flash Program Memory
 - Endurance: 10,000 minimum Write/Erase Cycles
- 32K Bytes of EEPROM, Including 64-byte OTP Area and 64-byte Bit-addressable Area
 - 1 to 128-byte Program/Erase
 - 2 ms Program, 2 ms Erase
 - Typically More than 500,000 Write/Erase Cycles
 - 10 Years Data Retention
- 1.5K Bytes RAM

Peripherals

- I/O Port
 - Configurable to Support Communication Protocols Including ISO 7816-3
- 16-bit Timer
- Random Number Generator (FIPS 140-1)
- 2-level, 4-vector Interrupt Controller

Security

- Advanced Protection Against Physical Attack
- Environmental Protection Systems
- Voltage Monitor
- Frequency Monitor
- Secure Memory Management/Access Protection (Supervisor Mode)

Development Tools

- Hardware Development Support on the Smart Card Development Kit (SDK)

Description

The AT90SC3232 is a low-power, high-performance, 8-bit microcontroller with Flash Program memory and EEPROM Data memory, based on the AVR enhanced RISC architecture. By executing powerful instructions in a single clock cycle, the AT90SC3232 achieves throughputs close to 1 MIPS per MHz. Its Harvard architecture includes 32 general-purpose working registers directly connected to the ALU, allowing two independent registers to be accessed in one single instruction executed in one clock cycle.

The AT90SC3232 includes 64K bytes of Atmel's high density, nonvolatile memory. The on-chip downloadable Flash allows the Program memory to be reprogrammed in-system. This technology combined with the versatile 8-bit CPU on a monolithic chip provides a highly flexible and cost-effective solution to many smart card applications.

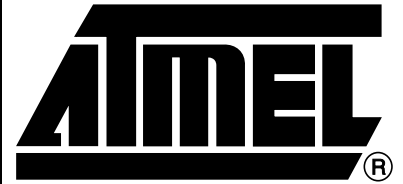

Secure Microcontroller for Smart Cards

AT90SC3232

Summary

Rev. 1316DS-10/01



Note: This is a summary document. A complete document will be available under NDA. For more information, please contact your local Atmel sales office.

Figure 1. The AT90SC3232 AVR Enhanced RISC Architecture

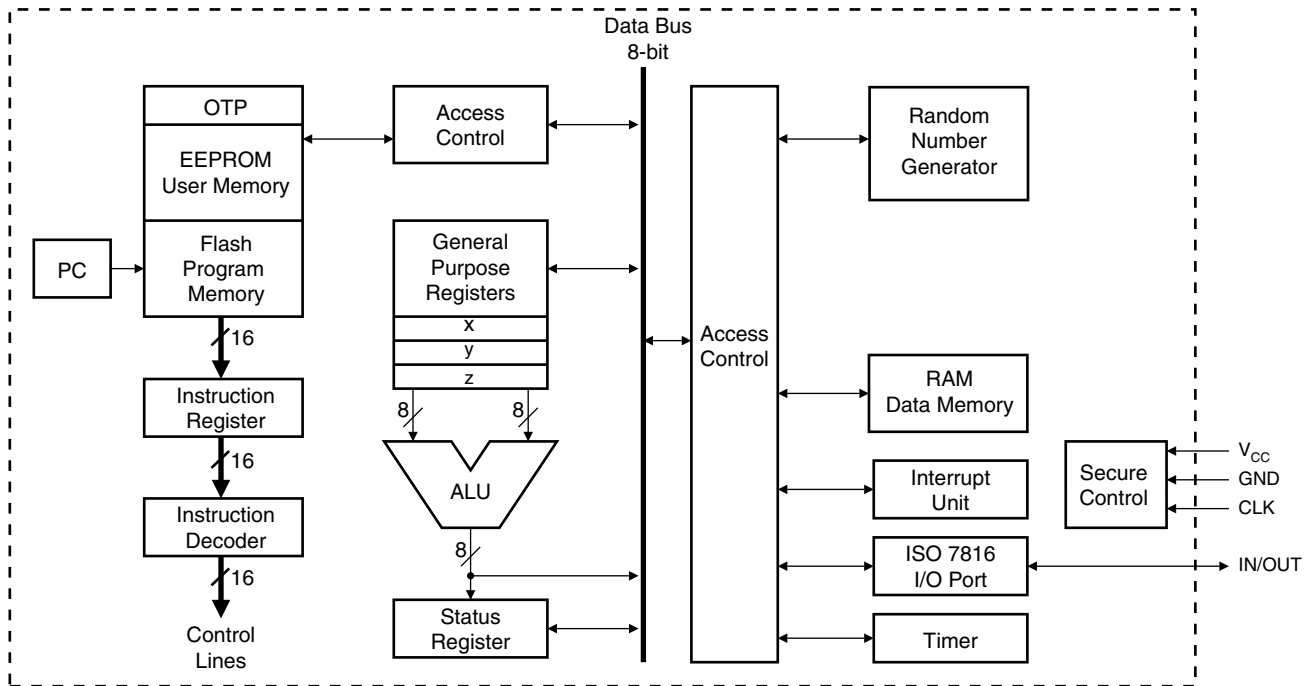

© Atmel Corporation 2001.

Atmel Corporation makes no warranty for the use of its products, other than those expressly contained in the Company's standard warranty which is detailed in Atmel's Terms and Conditions located on the Company's web site. The Company assumes no responsibility for any errors which may appear in this document, reserves the right to change devices or specifications detailed herein at any time without notice, and does not make any commitment to update the information contained herein. No licenses to patents or other intellectual property of Atmel are granted by the Com-

pany in connection with the sale of Atmel products, expressly or by implication. Atmel's products are not authorized for use as critical components in life support devices or systems.

Corporate Headquarters, 2325 Orchard Parkway, San Jose, CA 95131, TEL (408) 441-0311, FAX (408) 487-2600
 Atmel Colorado Springs, 1150 E. Cheyenne Mtn. Blvd., Colorado Springs, CO 80906, TEL (719) 576-3300, FAX (719) 540-1759
 Atmel Grenoble, Avenue de Rochepleine, BP 123, 38521 Saint-Egreve Cedex, France, TEL (33) 4-7658-3000, FAX (33) 4-7658-3480
 Atmel Heilbronn, Theresienstrasse 2, POB 3535, D-74025 Heilbronn, Germany, TEL (49) 71 31 67 25 94, FAX (49) 71 31 67 24 23
 Atmel Nantes, La Chantrerie, BP 70602, 44306 Nantes Cedex 3, France, TEL (33) 0 2 40 18 18 18, FAX (33) 0 2 40 18 19 60
 Atmel Rousset, Zone Industrielle, 13106 Rousset Cedex, France, TEL (33) 4-4253-6000, FAX (33) 4-4253-6001
 Atmel Smart Card ICs, Scottish Enterprise Technology Park, East Kilbride, Scotland G75 0QR, TEL (44) 1355-357-000, FAX (44) 1355-242-743

ATMEL® and AVR® are the registered trademarks of Atmel.

Other terms and product names may be the trademark of others.



Printed on recycled paper.