

# Dual preamplifier with ALC detector circuit

## BA3314F

The BA3314F is a dual preamplifier IC with built-in ALC detector circuit, designed for audio applications. It comes in a compact 14-pin SOP package, and has two record/playback preamplifiers, and an ALC detector circuit. The preamplifier can be directly coupled to the tape head without coupling capacitors to prevent tape head magnetization and "pop" noise generation.

With the built-in ALC detector circuit, an ALC circuit with large dynamic range can be constructed with addition of just an external time constant circuit.

### ●Applications

Audio equipment

### ●Features

- 1) Input bias circuit does not require coupling capacitors.
- 2) Built-in ALC circuit with external time constant circuit.
- 3) Wide operating power supply voltage range.
- 4) High gain.
- 5) Low noise.

### ●Block diagram

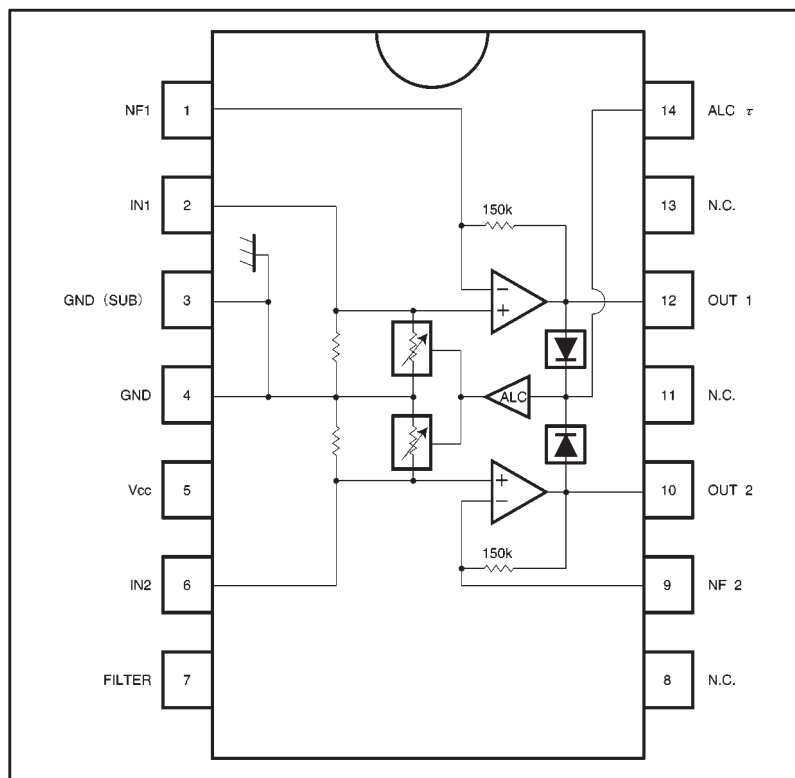

● Absolute maximum ratings (Ta = 25°C)

Parameter	Symbol	Limits	Unit
Power supply voltage	V <sub>CC</sub>	14	V
Power dissipation	P <sub>d</sub>	450*	mW
Operating temperature	T <sub>opr</sub>	-25~+75	°C
Storage temperature	T <sub>stg</sub>	-55~+125	°C

\* Reduced by 4.5mW for each increase in Ta of 1°C over 25°C.

● Recommended operating conditions (Ta = 25°C)

Parameter	Symbol	Min.	Typ.	Max.	Unit
Power supply voltage	V <sub>CC</sub>	5.0	—	12.0	V

● Electrical characteristics (unless otherwise noted, Ta = 25°C, V<sub>CC</sub> = 8V and f = 1kHz)

Parameter	Symbol	Min.	Typ.	Max.	Unit	Conditions
Quiescent current	I <sub>Q</sub>	1.5	3.0	6.0	mA	
Open loop voltage gain	G <sub>VO</sub>	70	85	—	dB	V <sub>O</sub> =1V <sub>rms</sub>
Closed loop voltage gain	G <sub>VC</sub>	49	52	55	dB	V <sub>O</sub> =0.3V <sub>rms</sub>
Total harmonic distortion	THD 1	—	0.3	1.0	%	V <sub>O</sub> =0.3V <sub>rms</sub>
Maximum output voltage	V <sub>OM</sub>	1.5	2.0	—	V <sub>rms</sub>	THD=1%
Input conversion noise voltage	V <sub>NIN</sub>	—	1.0	1.8	μV <sub>rms</sub>	R <sub>g</sub> =2.2kΩ, DIN AUDIO 45dB at 1kHz NAB
Input resistance	R <sub>IN</sub>	35	51	71	kΩ	
Channel separation	CS	40	55	—	dB	R <sub>g</sub> =2.2kΩ
ALC range *	ALC	40	53	—	dB	
ALC balance	ALB	—	0	3.0	dB	V <sub>IN</sub> =-45dBV
ALC distortion	THD 2	—	0.3	1.0	%	V <sub>IN</sub> =-45dBV
ALC output voltage	V <sub>ALC</sub>	700	850	1000	mV <sub>rms</sub>	V <sub>IN</sub> =-45dBV

\* The range for which the ALC begins to operate is the output voltage + 3dB with respect to the output voltage.

⊙ Not designed for radiation resistance.

● Measurement circuit

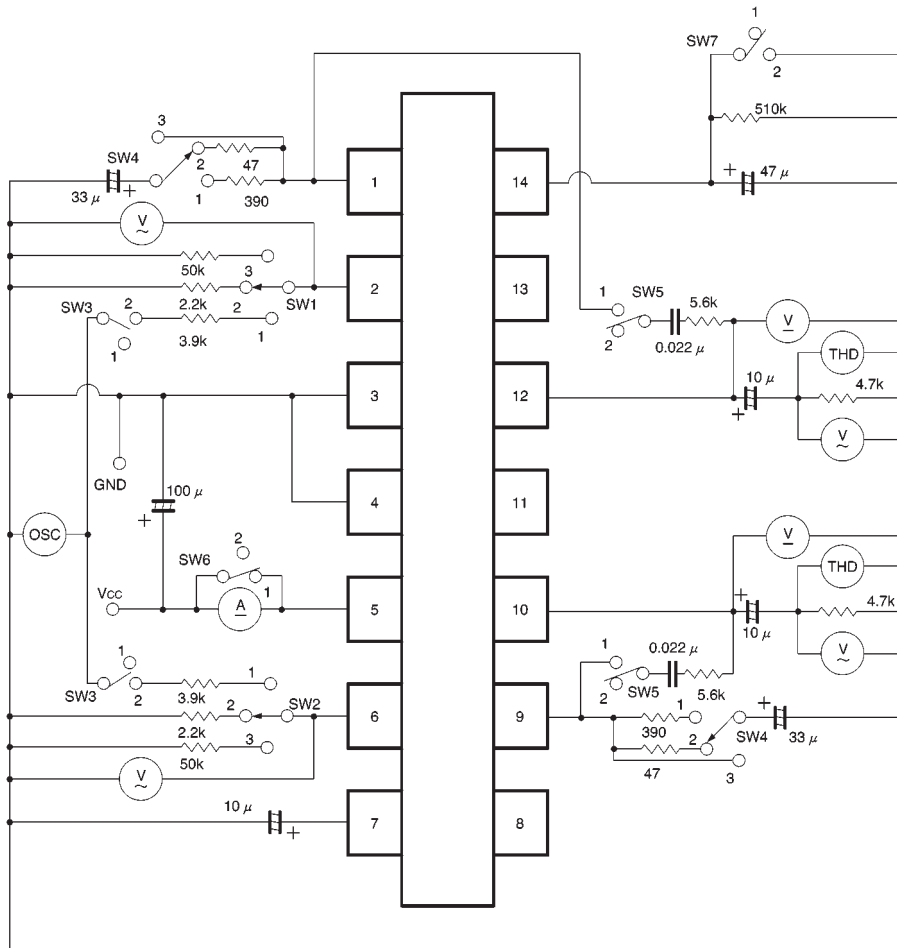

Fig. 1

Units	
Resistance	: Ω (±1%)
Film capacitors	: F (±1%)
Electrolytic capacitors	: F (±5%)

● Operation notes

Changing the input resistor  $R_g$ , and the ALC time constant influences the ALC transient characteristics. In particular, if  $R_g$  is less than 3.9kΩ or the time constant capacitor is less than 47µF, the ALC may operate excessively. Do not use smaller values than those recommended for these components.

● Application example

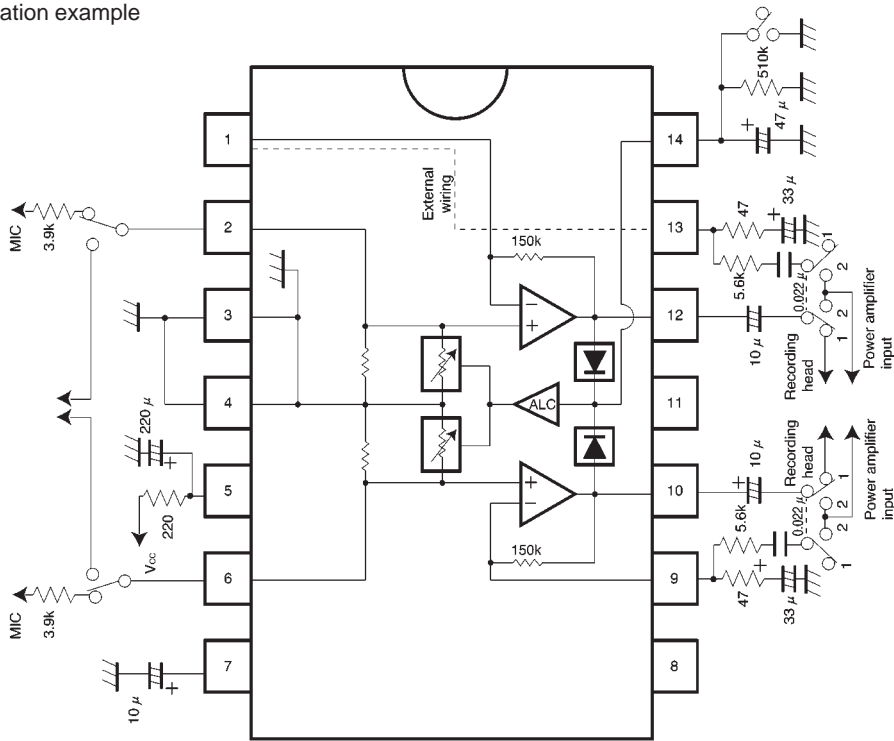

Fig. 2

SW

- 1: recording
- 2: playback

Units

- Resistance : Ω (± 5%)
- Film capacitors : F (± 10%)
- Electrolytic capacitors : F (± 20%)

● Electrical characteristics curve

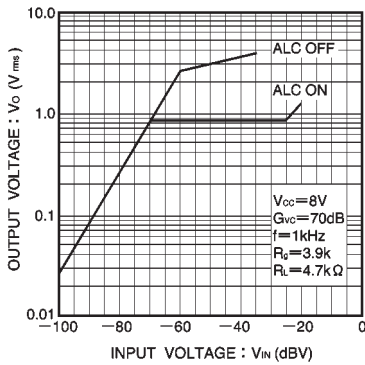
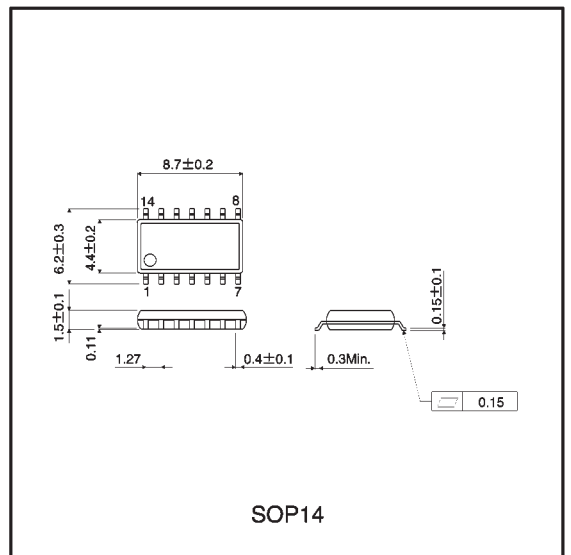

Fig. 3 Input voltage vs. output voltage

● External dimensions (Units: mm)



SOP14