

Stereo pre-amplifiers with mute detector circuits for car stereos

BA3430S/BA3430F/BA3430FS

The BA3430S, BA3430F, and BA3430FS are stereo pre-amplifiers with song gap detector circuits which have been designed for use in car stereos. The analog circuitry including the pre-amplifier and song gap detector and the digital circuitry such as control logic circuits have been combined together on a single chip. This has made it possible to reduce the interface with the microcontroller to five parallel inputs and outputs, and enables a very compact circuit configuration around the tape head.

The BA3430S, BA3430F, or BA3430FS makes it possible to easily incorporate an ultra-compact, high-precision pre-amplifier board into the mechanical components of a car stereo.

●Block diagram

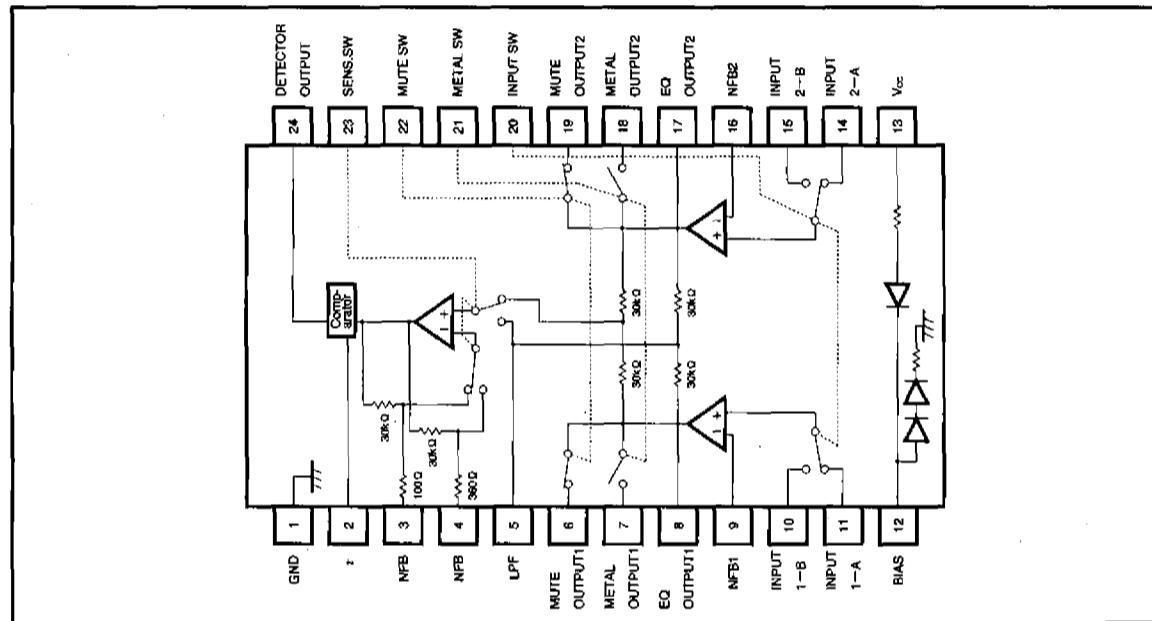

●Absolute maximum ratings (Ta = 25°C)

Parameter	Symbol	Limits	Unit
Supply voltage	Vcc	18	V
Power dissipation	BA3430S	1050*1	mW
	BA3430F	550*2	
	BA3430FS	800*3	
Operating temperature	Topr	-30~85	°C
Storage temperature	Tstg	-55~125	°C

- *1 When used above Ta = 25°C, decreases 10.5 mW per degree.
- *2 When mounted on 50 x 50 x 1.6 mm glass epoxy board.
When used above Ta = 25°C, decreases 5.5 mW per degree.
- *3 When mounted on 50 x 50 x 1.6 mm glass epoxy board.
When used above Ta = 25°C, decreases 8.0 mW per degree.

Low-frequency amplifiers

● Pin assignments

Pin No	Pin name	Function
1	GND	Substrate GND
2	τ	Song gap detection time constant
3	NFB	During playback, negative input of song gap detection amplifier
4	NFB	During fast forward, negative input of song gap detection amplifier
5	LPF	Low pass filter
6	MUTE OUTPUT1	Output 1 of mute amplifier
7	METAL OUTPUT1	Metal switch output 1
8	EQ OUTPUT1	Output 1 of equalizer amplifier
9	NFB1	Negative input 1 of equalizer amplifier
10	INPUT 1-B	Positive input 1-B of equalizer amplifier
11	INPUT 1-A	Positive input 1-A of equalizer amplifier
12	BIAS	Bias
13	V _{cc}	Voltage supply
14	INPUT 2-A	Positive input 2-A of equalizer amplifier
15	INPUT 2-B	Positive input 2-B of equalizer amplifier
16	NFB2	Negative input 2 of equalizer amplifier
17	EQ OUTPUT2	Output 2 of equalizer amplifier
18	METAL OUTPUT2	Metal switch output 2
19	MUTE OUTPUT2	Output 2 of mute amplifier
20	INPUT SW	Input switch control input
21	METAL SW	Metal switch control input
22	MUTE SW	Mute switch control input
23	SENS.SW	Switch control input for song gap detection sensitivity
24	DETECTOR OUTPUT	Song gap detection output

● Recommended conditions (Ta = 25°C)

Parameter	Symbol	Limits	Unit
Supply voltage	V _{cc}	7.0~18.0	V

● Electrical characteristics (unless otherwise indicated, Ta = 25°C and V_{cc} = 9V, f = 1kHz, R_g = 680Ω, V_o = 10dBV)

Parameter	Symbol	Min.	Typ.	Max.	Unit	Conditions	Measurement Circuit
Supply current	I _{cc}	—	10.3	16	mA	When quiescent	Fig.1
Open circuit voltage gain	G _{vo}	72	85	—	dB		Fig.1
Closed circuit voltage gain 1	G _{vc1}	37	40	43	dB		Fig.1
Closed circuit voltage gain 2	G _{vc2}	29	32	35	dB	f = 10kHz, during metal playback	Fig.1
Maximum output voltage	V _{ov}	0.5	0.9	—	V _{rms}	THD = 1%	Fig.1
Total harmonic distortion	THD	—	0.05	0.2	%		Fig.1
Input conversion noise voltage	V _{niw}	—	0.7	1.5	μV _{rms}	20~20kHz BPF	Fig.1
Ripple rejection rate	RR	40	50	—	dB	V _{rr} = -20dBV, f _{rr} = 100Hz	Fig.1
A-B crosstalk level	CT	55	65	—	dB		Fig.1
Channel separation	CS	55	65	—	dB		Fig.1
Mute level	ML	55	70	—	dB		Fig.1
Song detection input level 1	V _{on1}	-96.5	-93.5	-90.5	dBV	f = 5 kHz, during playback	Fig.1
Song detection input level 2	V _{on2}	-84	-81	-78	dBV	f = 10 kHz, during fast-forward	Fig.1
Song detection time	τ 1	—	6	—	ms		Fig.1
Song gap detection time	τ 2	—	45	—	ms		Fig.1
Logic low output sink current	I _{ol}	2	4	—	mA		Fig.1
Logic high output sink current	I _{oh}	—	1	3	μA		Fig.1
Low level logic input voltage	V _{il}	—	—	0.5	V		Fig.1
High level logic input voltage	V _{ih}	4.3	—	—	V		Fig.1
Control pin outflow current	I _{il}	—	—	200	μA	V _{il} = 0V	Fig.1
Control pin inflow current	I _{ih}	—	—	300	μA	V _{ih} = 5V	Fig.1

● Measurement circuit

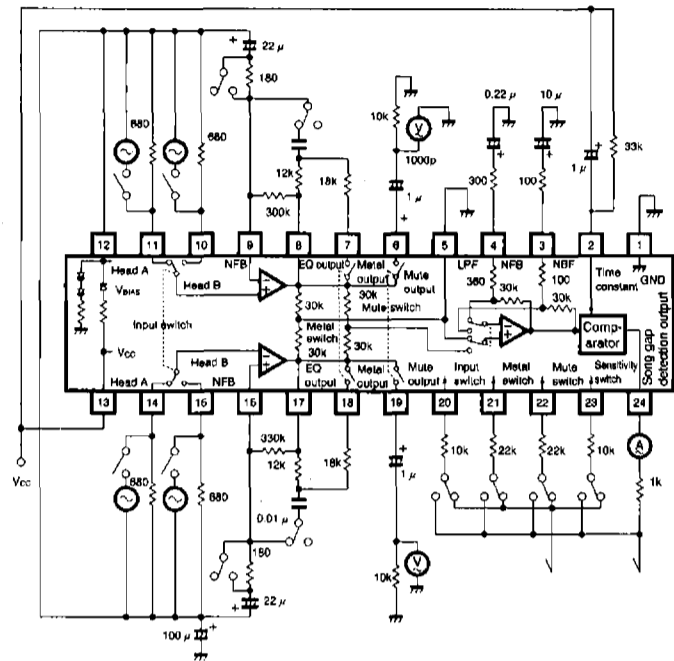

Fig. 1

● Audio signal amplification circuit

1) Input switch circuit

This circuit switches between head A and head B as needed for the auto reverse function. A 10kΩ or less resistor must be connected to the input pin to limit the input current.

Equivalent circuit schematic

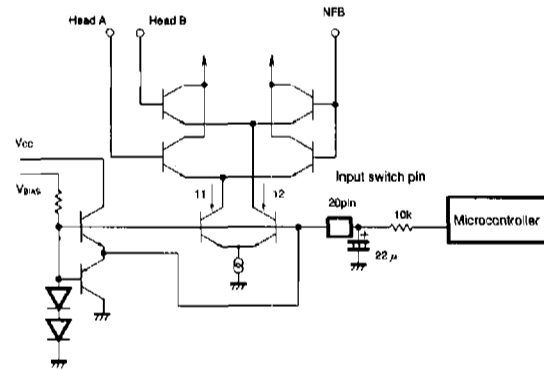

The electrolytic capacitor between the input pin and ground is for preventing switch noise. Although it is possible to prevent switch noise in the audio output without this capacitor by using the mute circuit, switch noise in the song gap detection circuit will not be prevented and noise will be recognized as a song.

Logic table

Pin 20 voltage	Head	Input pin
H	B	10, 15
L	A	11, 14

Preamplifiers
Low-frequency amplifiers

2) Equalizer amplifier and metal switch circuits

The signal input from the magnetic head will be amplified based on the NAB characteristics for normal tape or metal tape. The equalizer characteristics are switched between normal and metal according to the logic of the metal switch pin. A 22k Ω or less resistor must be connected to the input pin to limit the input current. The capacitor between the input pin and ground is for preventing switch noise. It can be omitted without causing incorrect song detection.

Equivalent circuit schematic

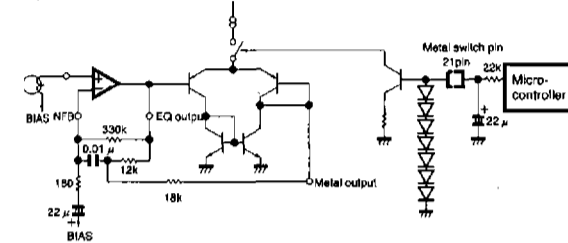

current. The capacitor between the input pin and ground is for preventing switch noise. It can be omitted without causing incorrect song detection.

Input switch logic table

Pin 21 voltage	Mode
H	Metal
L	Normal

3) Mute circuit

This circuit mutes the output of the equalizer amplifier. A 22k Ω or less resistor must be connected to the input pin to limit the input current. The electrolytic capacitor between the input pin and ground is for preventing switch noise. It can be omitted without causing incorrect song detection, however, it is best to use it to ensure proper operation of the mute circuit.

Input switch logic table

Pin 22 voltage	Output mode
H	Mute
L	Signal output

● Song gap detection circuit

1) Song gap detection based on noise and music signals

The signals of each block in the song gap detection circuit are shown in the diagram below.

Equivalent circuit schematic

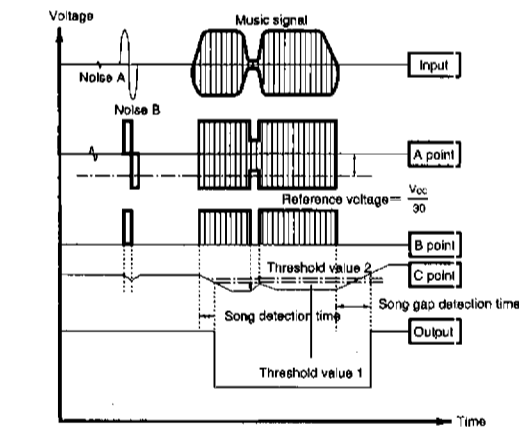
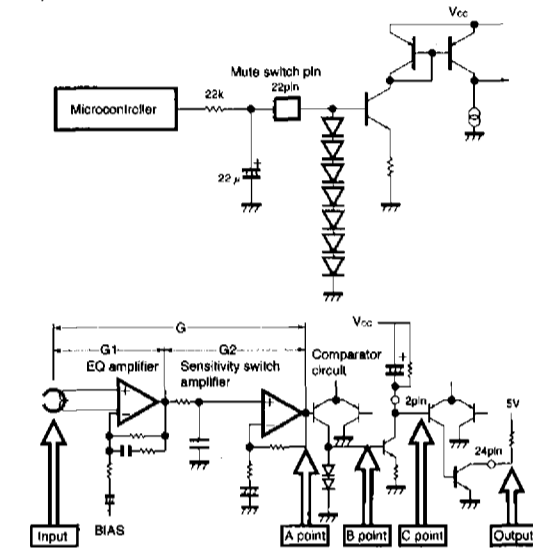

Fig. 3 Timing chart 1 (long time set for song gap detection)

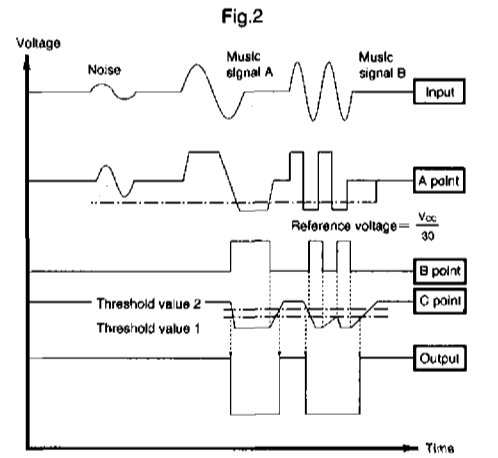

Fig. 4 Timing chart 1 (short time set for song gap detection)

2) Sensitivity switch amplifier circuit

The noise level and signal frequency of the tape differ during playback and fast forward. Therefore, this signal amplifier includes a circuit for switching the detection frequency and gain for playback and fast forward.

(1) Sensitivity switch circuit

This circuit switches the detection frequency and gain for playback and fast forward.

A 10kΩ or less resistor must be connected to the input pin to limit the input current. The electrolytic capacitor between the input pin and ground is for preventing incorrect detection. Without this capacitor, sensitivity switch noise may cause incorrect detection of songs.

Input switch logic table

Pin 23 voltage	Song gap detection mode
H	Fast forward
L	Playback

(2) Input low pass filter

High frequency noise increases during fast forward. This filter reduces high frequency noise. It consists of an internal 30kΩ resistor which combines the left and right equalizer output and an external capacitor connected to Pin 5.

The cutoff frequency of the low pass filter f_H is

$$f_H = \frac{1}{2 \times \pi \times C \times 30k // 30k} \text{ (Hz)}$$

C = External capacitor connected to Pin 5

(3) Sensitivity switch amplifier

Equivalent circuit schematic

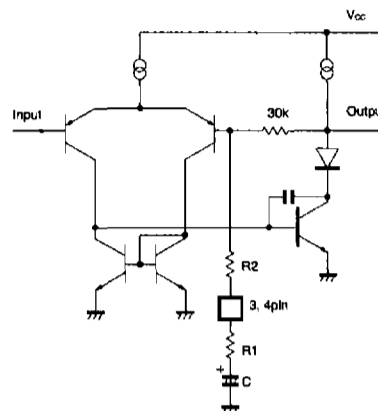

R2 is a resistor inside the IC which is 100Ω during playback and 360Ω during fast forward.

The gain of the amplifier is

$$G = 20 \times \log \frac{30k + R1 + R2}{R1 + R2} \text{ (dB)}$$

The low cutoff frequency f_L of the amplifier is

$$f_L = \frac{1}{2 \times \pi \times C \times (R1 + R2)} \text{ (Hz)}$$

(4) Comparator circuit

This circuit detects the presence or not of the signal and outputs a detection signal.

The circuit consists of two comparators. The first comparator detects the level of the signal and the second comparator detects the duration of the signal.

When a signal above $V_{CC} / 30$ ($V_{O.P}$) is input, the first comparator turns on and draws a constant current I from the time constant pin. This causes the voltage of the time constant pin to fall, and when it drops below $V_{CC} - 2.7(V)$ the next comparator turns on, changing the song gap detection output pin to low.

If the signal level drops below $V_{CC} / 30$ ($V_{O.P}$), the first comparator turns off and the voltage of the time constant pin rises due to the external discharge resistor. When this voltage rises above $V_{CC} - 2.0(V)$, the next comparator turns off, changing the song gap detection output pin to high.

The time τ_1 from the arrival of the signal to the changeover of the song gap detection output pin to low is given as follows :

$$\tau_1 = \frac{5.4 \times C}{I} \quad (S)$$

This equation holds when the input signal is sufficiently large.

See Fig. 20 for the small signal time τ_1 .

The time τ_2 from the ceasing of the signal to the changeover of the song gap detection output pin to high is as follows :

$$\tau_2 = C \times R \times \ln \frac{1/2 \times V_{CC} + 2.0}{2.0} \quad (S)$$

I : Output current of first comparator = approx. 1mA
 C : External capacitor connected to time constant pin
 R : External resistor connected to time constant pin (this should be 22kΩ or higher)

Equivalent circuit schematic

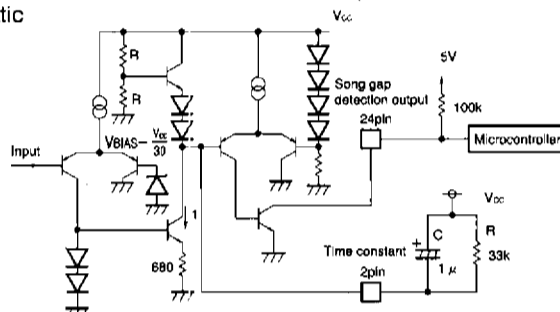

(5) Gain settings for the song gap detection circuit

The gain settings for the song gap detection circuit are shown below. The reference voltage of the comparator circuit is set at $V_{CC} / 30$.

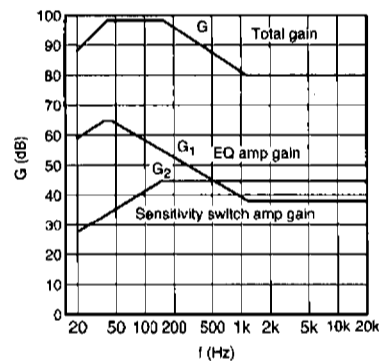

Fig. 5 During playback

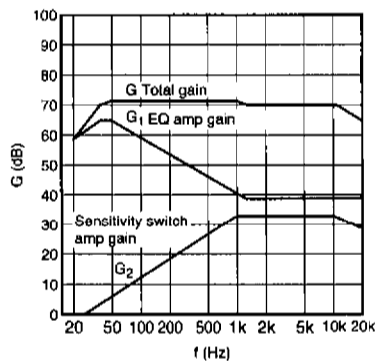

Fig. 6 During fast forward

As an example, when $V_{CC} = 9V$ and $f = 5kHz$, the song gap detection level during playback is obtained as follows :

a. The reference voltage of the comparator circuit is $V = V_{CC} / 30 = 0.3V$, therefore, the circuit will operate at an AC input of $0.3 / \sqrt{2} V_{rms} = -13.5dBV$ or more.

b. From the above chart, the gain at 5kHz during playback is 80dB.

c. Therefore, the output/input level of song gap detection is $-13.5 - 80 = -93.5dBV$.

● Application example

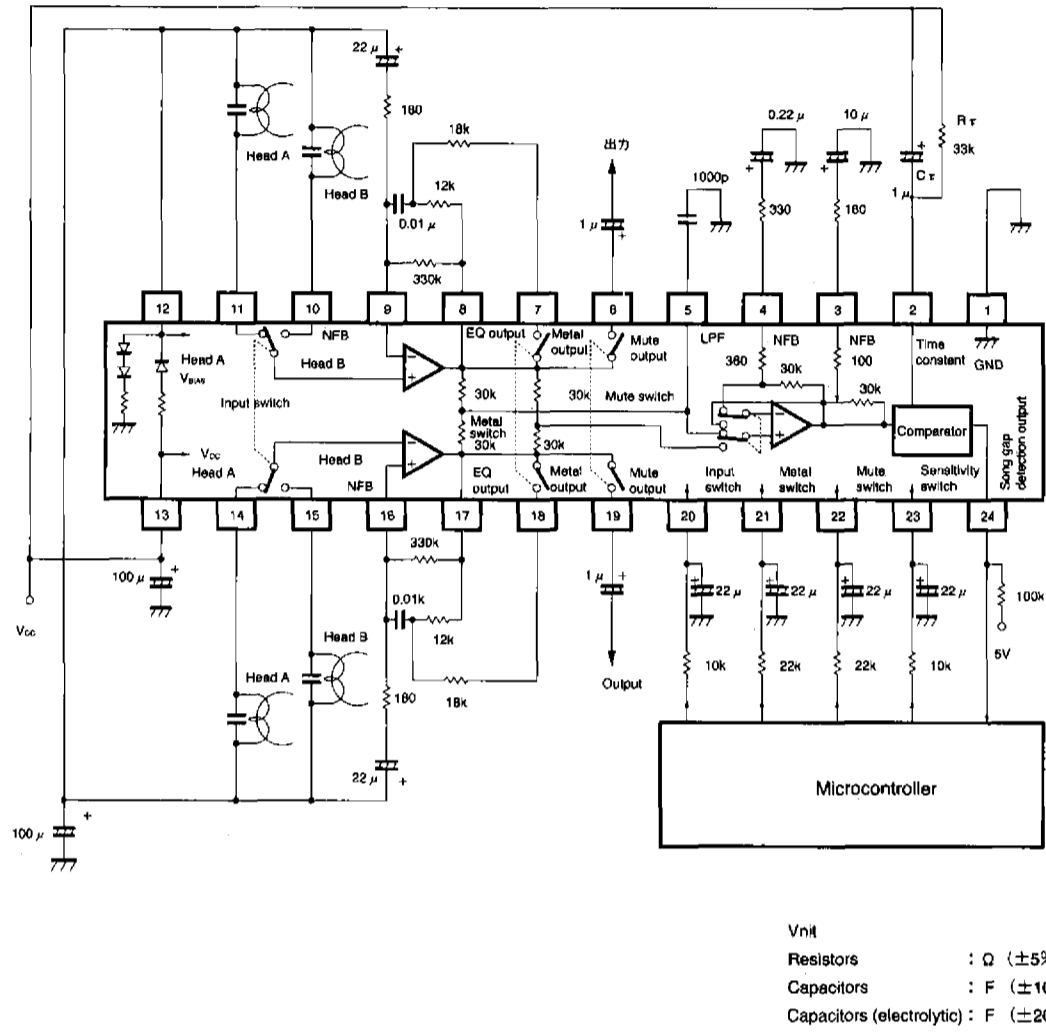

Fig. 7

Pre-amplifiers
Low-frequency amplifiers

●Precautions

1) Application circuit

The application circuit is an example of a circuit we recommend, however, before using it further examination of characteristics and patent issues is necessary. If any of the values of the external connections are changed, be sure to take into consideration both the quiescent and transient characteristics of the IC and external components, and also deviations in the characteristics.

2) Resistor values for switch pins

To prevent incorrect operation of the switch pins, use a 3k to 10kΩ resistor at Pins 20 and 23, and a 2k to 22kΩ resistor at Pins 21 and 22.

3) Capacitors for switch pins

The capacitors connected to Pins 20 and 23 are for preventing incorrect operation of the song gap detection circuit. Without these capacitors, the switching sound which occurs when the internal switches are switched will cause the song gap detection output pin (Pin 24) to go low even when there is no signal, and this error will continue throughout the song gap detection time. If a short song gap detection time is set and the error can be tolerated, the capacitors can be omitted. The capacitors at Pins 21 and 22 are for preventing a "pop" sound in the audio signal. If the pop sound is muted at a latter stage, the capacitors can be omitted. Naturally, the song gap detection circuit will still operate correctly if they are omitted.

4) Song detection output/input level

The song detection output / input level can be set with the resistors connected to Pins 3 and 4. Small values for these resistors will create a large amplifier gain, lowering the song detection output / input level. The song detection output / input level in the application circuit is -93.5dBV (5kHz) during playback and -81dBV (10kHz) during fast forward.

5) Frequency characteristics of sensitivity switch amplifier

The low cutoff frequency during playback can be set with the capacitor and resistor values of Pin 3. The low cutoff frequency during fast forward can be set with the capacitor and resistor values of Pin 4, and the high cutoff frequency can be set with the capacitor connected to Pin 5 and the internal resistor.

6) Song detection time

The song detection time can be set with the capacitor connected to Pin 2. If the time is too short, short noise signals will also cause the circuit to operate. Set the time as long as possible.

7) Song gap detection time

The song gap detection time is proportional to the product of the capacitor and resistor between the supply voltage and Pin 2. Taking into consideration the allowed IC current, select a resistor which is 22kΩ or more.

	Pin 20 C		Pin 21 C		Pin 22 C		Pin 23 C	
	Yes	No	Yes	No	Yes	No	Yes	No
Pop sound in audio signal	△	×	○	△	○	×	○	○
Song gap detection circuit error	○	×	○	○	○	○	○	*

× . . . Occurs

○ . . . Does not occur

△ . . . May occur due to gain in following stage

* . . . Possibility of incorrect operation

● Thermal reduction curves

As the allowed power dissipation of the BA3430F / BA3430FS is small (BA3430F = 550mW, BA3430FS = 800mW), high temperature or high current may cause the allowed power dissipation to be exceeded. Fig. 8 shows the internal power dissipation vs. supply voltage (P_d vs. V_{CC}), and Fig. 9 shows the allowed power dissipation vs. ambient temperature (P_{dMAX} vs. T_a). Allowed supply voltage vs. ambient temperature (V_{CCMAX} vs. T_a) can be obtained from these curves, and the result is shown in Fig. 10. Refer to Fig. 10 to set the supply voltage when designing the application.

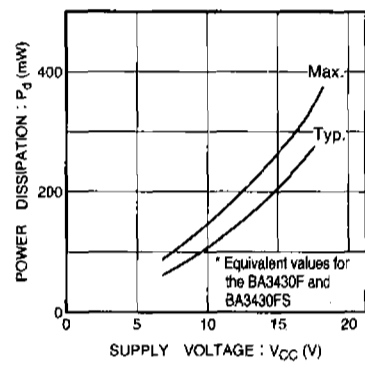

Fig. 8 P_d vs. V_{CC}

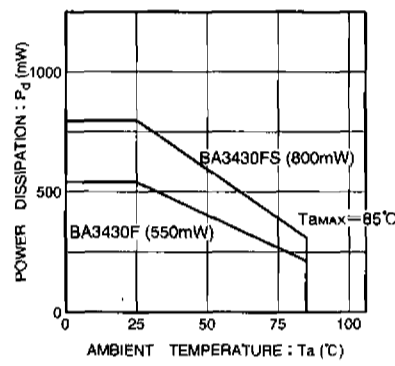

Fig. 9 P_{dMAX} vs. T_a

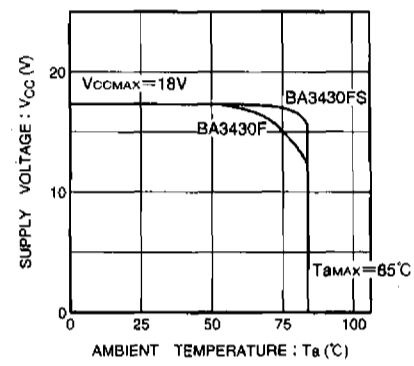

Fig. 10 V_{CCMAX} vs. T_a

● Measurement data

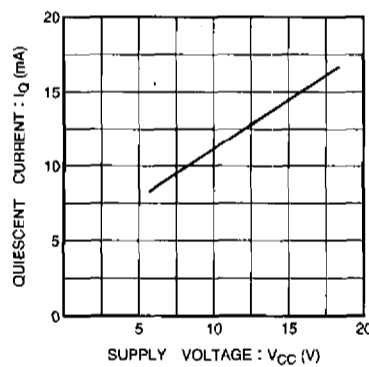

Fig. 11 Quiescent current vs. supply voltage

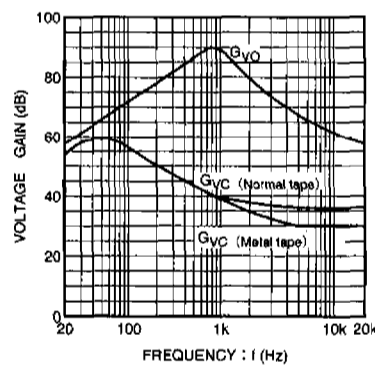

Fig. 12 Open loop voltage gain and closed loop voltage gain vs. frequency

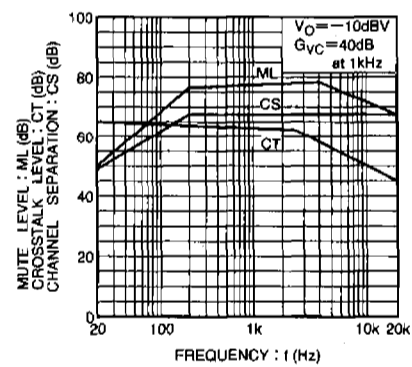

Fig. 13 Mute level frequency, crosstalk level and channel separation vs. frequency

Preamplifiers

Low-frequency amplifiers

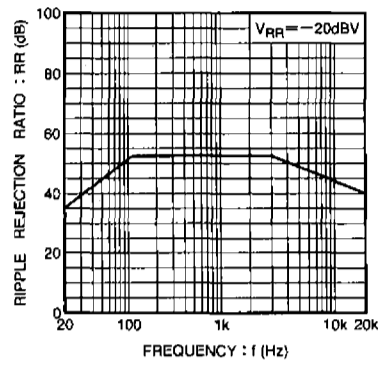

Fig. 14 Ripple rejection ratio vs. frequency

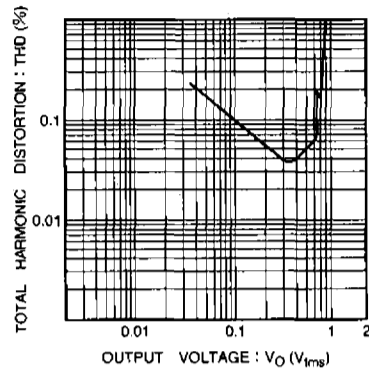

Fig. 15 Total harmonic distortion vs. output voltage

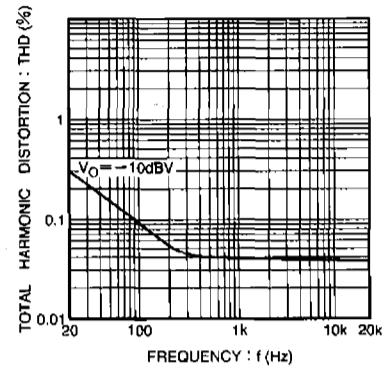

Fig. 16 Total harmonic distortion vs. frequency

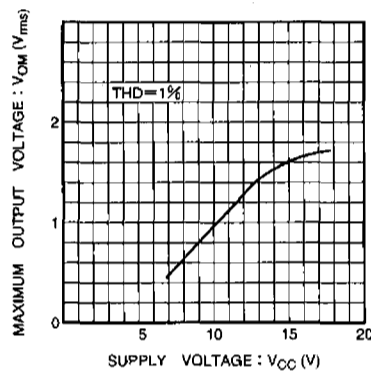

Fig. 17 Maximum output voltage vs. supply voltage

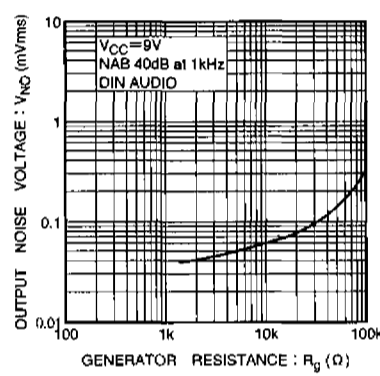

Fig. 18 Output noise voltage vs. generator resistance

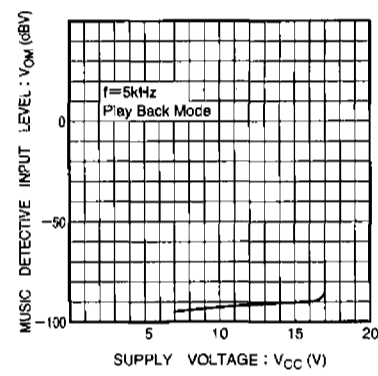

Fig. 19 Music detectable input level vs. supply voltage

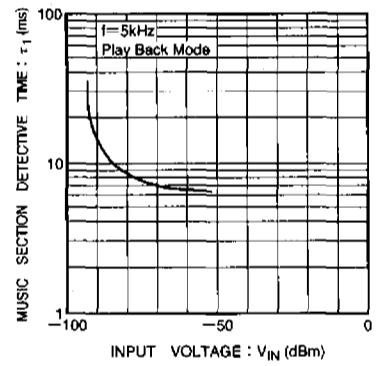

Fig. 20 Music section detectable time vs. input voltage

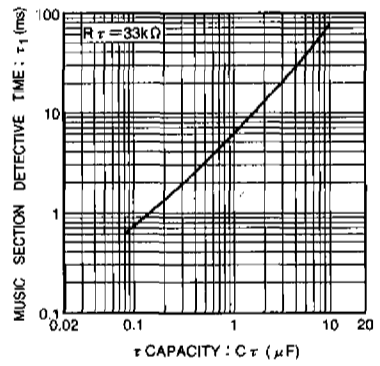

Fig. 21 Music section detectable time vs. time constant capacity

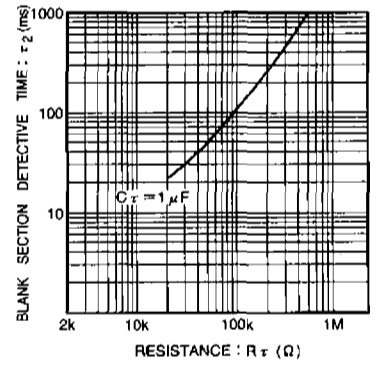

Fig. 22 Blank section detectable vs. time constant resistance

LOW

305

Low-frequency amplifiers



Audio ICs

BA3430S/BA3430F/BA3430FS

External dimensions (Unit: mm)

