

2-phase half-wave motor driver

BA6407AF

The BA6407AF is a motor driver dedicated to 12V fan motors. Built-in output transistors reduce the number of external components required. The IC has a lock signal output pin.

●Applications

Fan motors

●Features

- 1) Lock detection and rotational speed sensing mechanisms are built in.
- 2) Compact SOP 8-pin package reduces the number of external components required.
- 3) Automatic restart when the motor lock is undone.

●Absolute maximum ratings (Ta = 25°C)

Parameter	Symbol	Limits	Unit
Power supply voltage	V _{CC}	15	V
Power dissipation	P _d	550*1	mW
Operating temperature	T _{opr}	-25~+75	°C
Storage temperature	T _{stg}	-55~+150	°C
Output current	I _{OUT}	1.2*2	A
Output withstanding voltage	V _{OUT}	30	V
Alarm output pin withstanding voltage	V _{AL}	15	V

*1 Reduce by 4.4 mW for each increase in Ta of 1°C over 25 °C.

(When mounted on a glass epoxy board 50.0×50.0×1.6 mm) .

*2 Should not exceed Pd or ASO values.

●Recommended operating conditions (Ta = 25°C)

Parameter	Symbol	Min.	Typ.	Max.	Unit
Operating power supply voltage	V _{CC}	5	—	14.5	V

● Block diagram

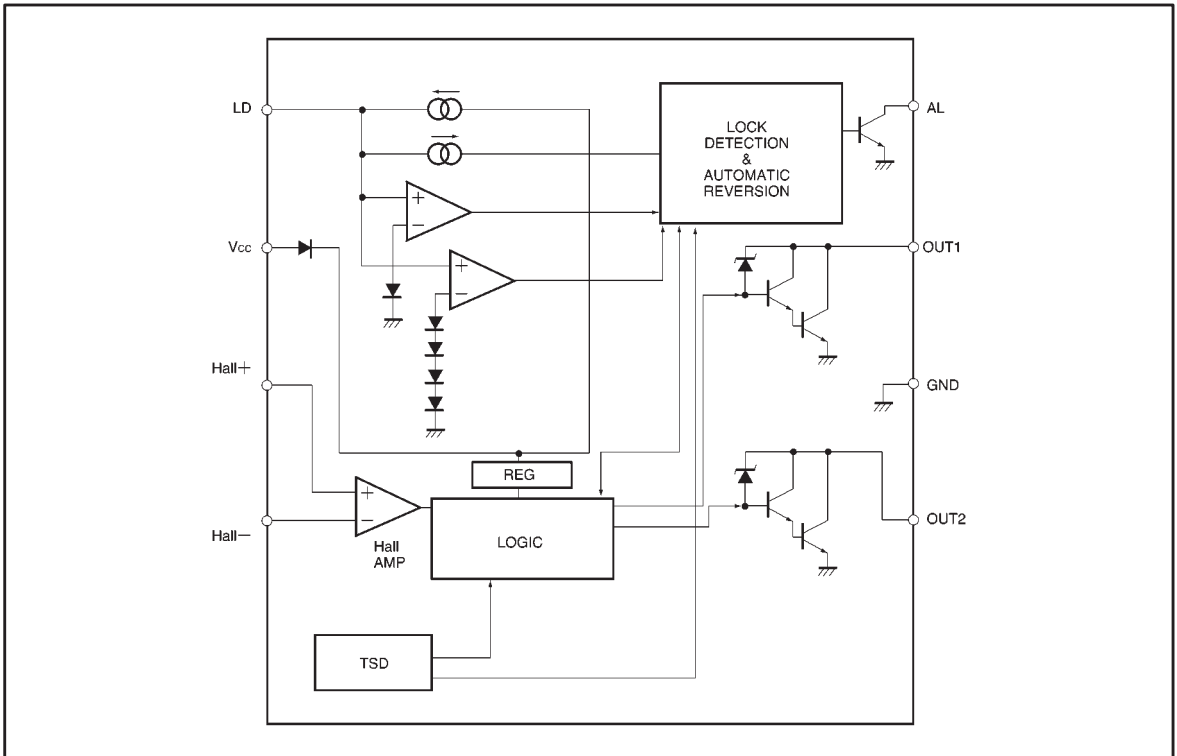

● Pin descriptions

Pin No.	Pin name	Function
1	OUT 2	Output 2
2	AL	Alarm output
3	LD	Capacitor connection pin for lock detection and automatic restart
4	Vcc	Supply voltage
5	Hall+	Hall input (+)
6	Hall-	Hall input (-)
7	OUT 1	Output 1
8	GND	GND

●Electrical characteristics (unless otherwise noted, Ta = 25°C and V_{CC} = 12V)

Parameter	Symbol	Min.	Typ.	Max.	Unit	Conditions
Supply current	I _{CC}	2.0	4.5	7.0	mA	When output is OFF
Lock detection capacitor charge current	I _{LDC}	1.56	3.4	5.25	μA	V _{LD} =1.8V
Lock detection capacitor discharge current	I _{LDD}	0.24	0.79	1.34	μA	V _{LD} =1.8V
Lock detection capacitor charge/discharge ratio	r _{CD}	3.0	4.3	8.0	—	r _{CD} =I _{LDC} / I _{LDD}
Lock detection capacitor clamp voltage	V _{LDCL}	2.1	2.48	3.0	V	
Lock detection capacitor comparator voltage	V _{LDLCP}	0.7	0.99	1.2	V	
Output low level voltage	V _{OL}	—	0.8	1.1	V	I _O =200mA
Output leakage current	I _{OL}	—	0	10	μA	
Output zener voltage	V _{OZ}	26	28	30	V	Clamp current = 10mA
Alarm output pin low level voltage	V _{ALL}	—	0.3	1.0	V	I _O =10mA
Alarm output pin leakage current	I _{ALL}	—	0	10	μA	

◎Not designed for radiation resistance.

●Lock detection

The automatic restart circuit detects a motor lock condition and automatically turns off the output current. When the lock condition is cleared, the IC automatically restarts and allow the motor to run.

In the BA6407AF, automatic restart is performed as follows.

A motor lock condition is detected when the Hall signal stops switching.

The output is ON when the LD pin is being charged, and OFF when the pin is being discharged.

- The AL pin is ON during normal operation, and OFF when the motor is locked.
- The AL pin is an open collector output.

Output ON time (T_{ON}) and OFF time (T_{OFF}) determined by the LD capacitor

$$T_{ON} \text{ (Charge time)} = \frac{C \cdot (V_{LDCL} - V_{LDLCP})}{I_{LDC}}$$

$$T_{OFF} \text{ (Discharge time)} = \frac{C \cdot (V_{LDCL} - V_{LDLCP})}{I_{LDD}}$$

(Typical value)

where

C is the capacitance of the LD-pin external capacitor, V_{LDCL} is the LD-pin clamp voltage (2.48V), V_{LDLCP} is the LD-pin comparator voltage (0.99V), I_{LDC} is the LD-pin charge current (3.4μA), I_{LDD} is the LD-pin discharge current (0.79μA).

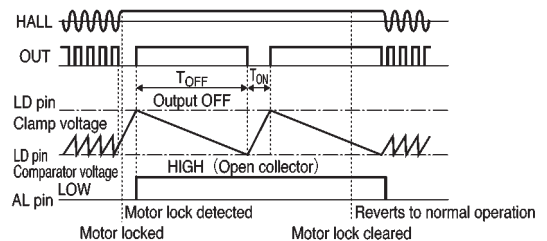

Fig.1

●Application example

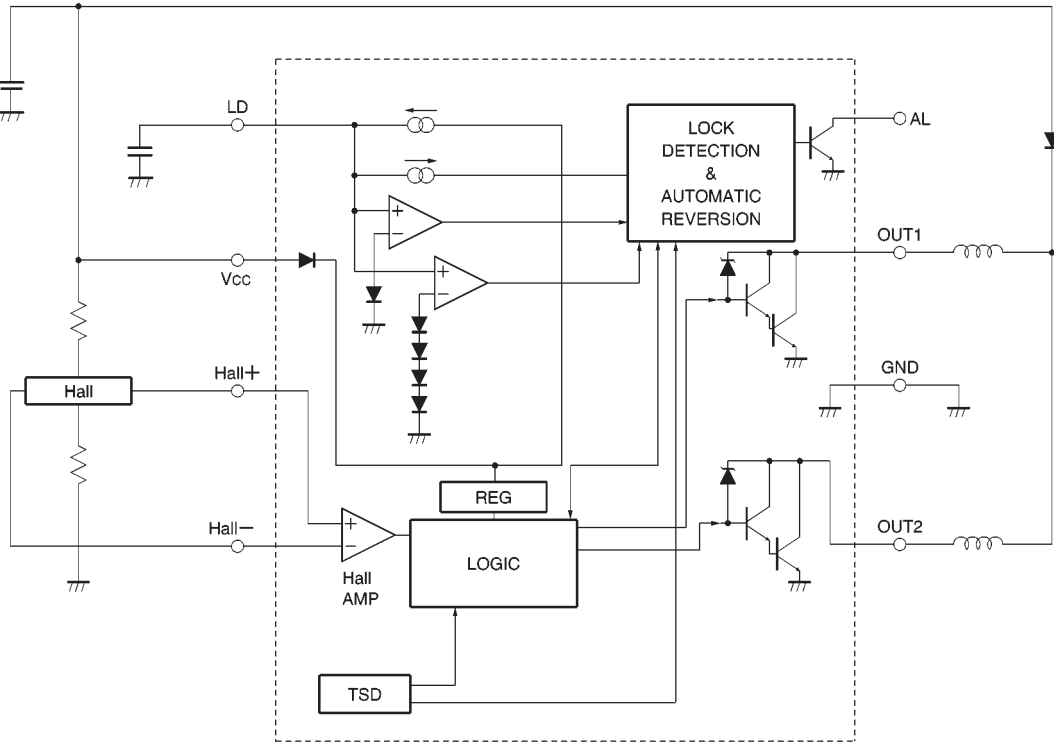
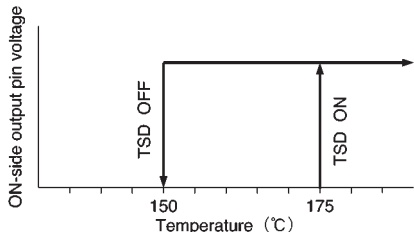

Fig.2

● Operation notes

(1) Thermal shutdown circuit

The IC has a built-in thermal shutdown circuit. There is a temperature difference of 25°C (typical) between the temperatures at which the circuit is activated and deactivated.



TSD ON (175°C Typ.): All outputs are turned OFF.
 TSD OFF: Normal operation resumes when the circuit is deactivated.
 There is a temperature difference of 25°C (typical) between the temperatures at which the circuit is activated and deactivated.

Fig.3

(2) Power dissipation

Power consumed in the IC can be calculated from the following equation :

$$P_C = P_{C1} + P_{C2} + P_{C3}$$

P_{C1} is power consumed by the supply current.

$$P_{C1} = V_{CC} \times I_{CC}$$

P_{C2} is the output current consumption.

$$P_{C2} = V_{OL} \times I_O$$

V_{OL} is the LOW level voltage of output pins 1 and 2.

P_{C3} is power consumed by the AL pin.

$$P_{C3} = V_{ALL} \times I_{AL}$$

where V_{ALL} is the AL-pin LOW level voltage and I_{AL} is the AL-pin sink current. Make sure that your application does not exceed the allowable power dissipation of the IC.

(3) Hall amplifier input voltage

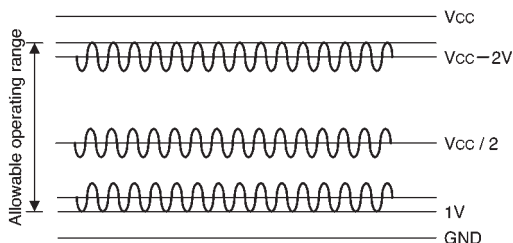

Fig.4 Hall amplifier input bias voltage

The Hall current is given by:
$$\frac{V_{CC}}{R_1 + R_2 + R_H}$$

where R_H is the hall device impedance.

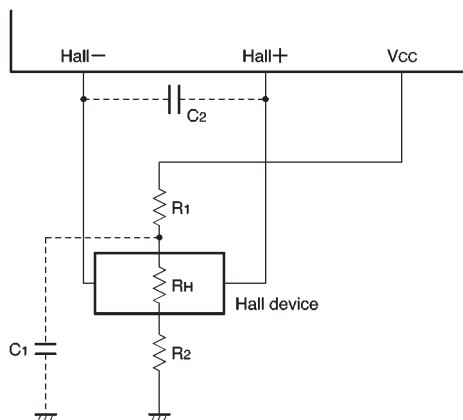

Fig.5

The R_1 and R_2 resistances must be set so as to maintain the Hall amplifier input bias voltage within the range of 1V to $(V_{CC} - 2V)$ including the signal amplitude. It is recommended that the same value be used for both resistors so that the Hall device output signal is centered around $V_{CC} / 2$.

The Hall device may be affected by power supply noise due to the PCB conductor pattern. If you have this problem, insert a capacitor C_1 as shown in Fig. 5.

If the conductor lines from the Hall device output terminals to the Hall inputs of the IC are particularly long, noise can be picked up and fed into the inputs. If you have this problem, insert a capacitor C_2 as shown in Fig. 5. Note that the Hall inputs have no hysteresis in this IC.

●Electrical characteristic curves

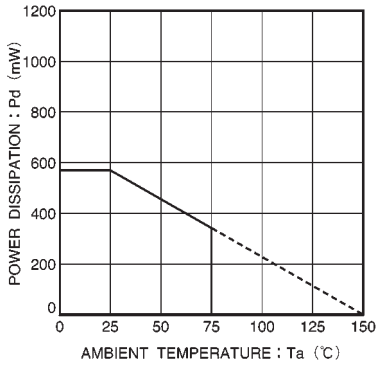

Fig.6 Thermal derating curve

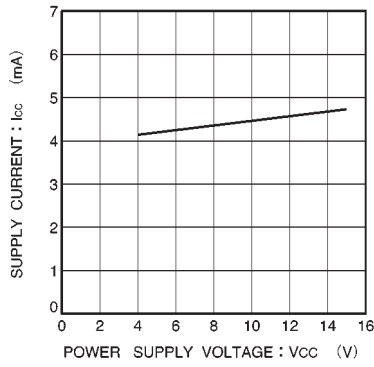

Fig.7 Supply current vs. power supply voltage

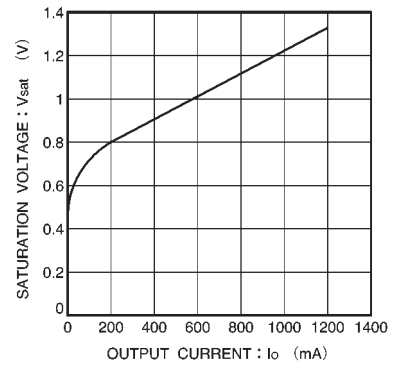

Fig.8 Output saturation voltage vs. output current

●External dimensions (Units: mm)

