

4-channel BTL driver for CD players

BA6790FP / BA6791FP

The BA6790FP and BA6791FP are 4-channel BTL drivers for CD player actuators and motors. These ICs have internal 5 V regulators and general purpose operational amplifiers, and are mounted to a 28-pin HSOP package, allowing for the miniaturization of applications.

● Applications

CD players and portable CD

● Features

- 1) 4-channel BTL driver.
- 2) HSOP 28-pin package allows for miniaturization of applications.
- 3) Wide dynamic range. (typically 5.4V when $V_{CC} = 8V$ and $R_L = 8\Omega$)
- 4) Internal thermal shutdown circuit.
- 5) Gain is adjustable with a single attached resistor.
- 6) Internal 5V regulator. (requires attached PNP transistor)
- 7) Internal general purpose operational amplifier.

● Block diagram

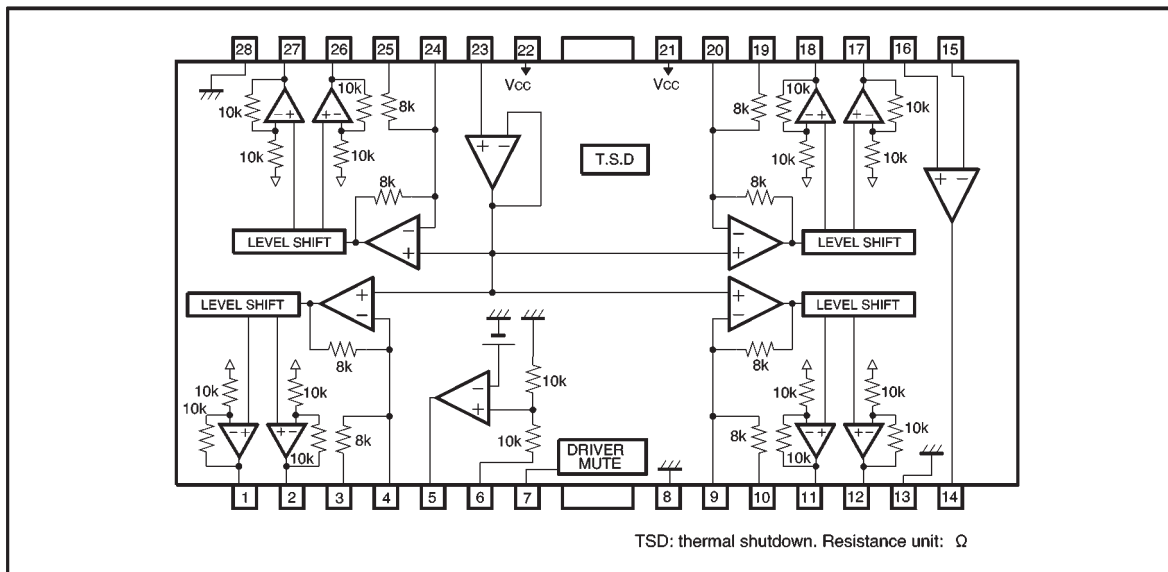

● Pin descriptions

Pin No.	Pin name	Function	Pin No.	Pin name	Function
1	VO1 (−)	Driver channel 1 negative output	15	OP IN (−)	Operational amplifier input, negative
2	VO1 (+)	Driver channel 1 positive output	16	OP IN (+)	Operational amplifier input, positive
3	VIN1	Driver channel 1 input	17	VO3 (−)	Driver channel 3 negative output
4	VIN1'	Driver channel 1 input, gain adjustment pin	18	VO3 (+)	Driver channel 3 positive output
5	REG−B	Connect to external transistor base	19	VIN3	Driver channel 3 input
6	REG OUT	Constant voltage output, connects to external transistor collector	20	VIN3'	Driver channel 3 gain adjustment pin
7	MUTE	Mute control pin	21	V _{cc}	Power supply
8	GND	Ground	22	V _{cc}	Power supply
9	VIN2'	Driver channel 2 input, gain adjustment pin	23	BIAS IN	Bias amplifier input
10	VIN2	Driver channel 2 input	24	VIN4'	Driver channel 4 gain adjustment pin
11	VO2 (+)	Driver channel 2 positive output	25	VIN4	Driver channel 4 input
12	VO2 (−)	Driver channel 2 negative output	26	VO4 (+)	Driver channel 4 positive output
13	GND	Substrate ground	27	VO4 (−)	Driver channel 4 negative output
14	OP OUT	Operational amplifier output	28	GND	Substrate ground

Note: Positive and negative output of the driver is relative to the polarity of the input pins
When the input pin is HIGH, negative output pin is LOW and positive output pin is HIGH.

● Absolute maximum ratings (Ta = 25°C)

Parameter	Symbol	Limits	Unit
Power supply voltage	V _{cc}	18	V
Power dissipation	P _d	1.7*1	W
Operating temperature	T _{opr}	−35~+85	°C
Storage temperature	T _{stg}	−55~+150	°C

*1 Reduced by 13.6 mW for each increase in Ta of 1°C over 25°C.
When mounted on a 50 mm × 50 mm × 1.0 mm paper phenol board.

● Recommended operating conditions

Parameter	Symbol	Limits	Unit
Power supply voltage	V _{cc}	6.0~9.0*2	V

*2 4.5-9 V without regulator (pins 5 and 6 may be opened)

●Electrical characteristics (unless otherwise noted, Ta = 25°C, V_{CC} = 8V, f = 1kHz, R_L = 8Ω)

Parameter	Symbol	Min.	Typ.	Max.	Unit	Conditions	Measurement Circuit
Quiescent current dissipation	I _{CC}	—	9.0	12.0	mA	No load	Fig. 1
Output voltage, offset	V _{OO}	−50	—	50	mV		Fig. 1
Maximum output amplitude	V _{OM}	5.0	5.4	—	V		Fig. 1
Closed loop voltage gain	G _{VC}	10.5	12.0	13.5	dB	V _{IN} =0.1V _{rms} , 1kHz	Fig. 1
Ripple rejection	RR	—	60	—	dB	V _{IN} =0.1V _{rms} , 100Hz	Fig. 1
Slew rate	SR	—	2.0	—	V/μs	100 kHz square wave, 3 V _{P-P} output	Fig. 1
Mute On voltage	V _{MON}	—	—	0.5	V		Fig. 1
Mute Off voltage	V _{MOFF}	2.0	—	—	V		Fig. 1
〈5 V regulator〉							
Output voltage	V _{REG}	4.75	5.00	5.25	V	I _L =100mA	Fig. 1
Output load variation	ΔV _{RL}	−50	0	10	mV	I _L =0~200mA	Fig. 1
Supply voltage variation	ΔV _{VCC}	−10	0	25	mV	(V _{CC} =6~9V) I _L =100mA	Fig. 1
〈Operational amplifier〉							
Offset voltage	V _{OFOP}	−5	0	5	mV		Fig. 1
Input bias current	V _{BOP}	—	—	300	nA		Fig. 1
Output high level voltage	V _{OHOP}	6.0	—	—	V		Fig. 1
Output low level voltage	V _{OLOP}	—	—	1.8*	V	BA6790FP	Fig. 1
Output drive current (sink)	I _{SINK}	10	50	—	mA	V _{CC} at 50Ω	Fig. 1
Output drive current (source)	I _{SOURCE}	10	40	—	mA	50Ω at ground	Fig. 1
Open loop voltage gain	G _{VO}	—	78	—	dB	V _{IN} =−75dBV, 1kHz	Fig. 1
Slew rate	SR _{OP}	—	1	—	V/μs	100 kHz square wave, 4 V _{P-P} output	Fig. 1
Ripple rejection	RR _{OP}	—	65	—	dB	V _{IN} =−20dBV, 100Hz	Fig. 1
Common mode rejection ratio	CMRR	—	84	—	dB	V _{IN} =−20dBV, 1kHz	Fig. 1

* Low-level output voltage (V_{olop}) of BA6791FP = 1.1 V

● Measurement circuit

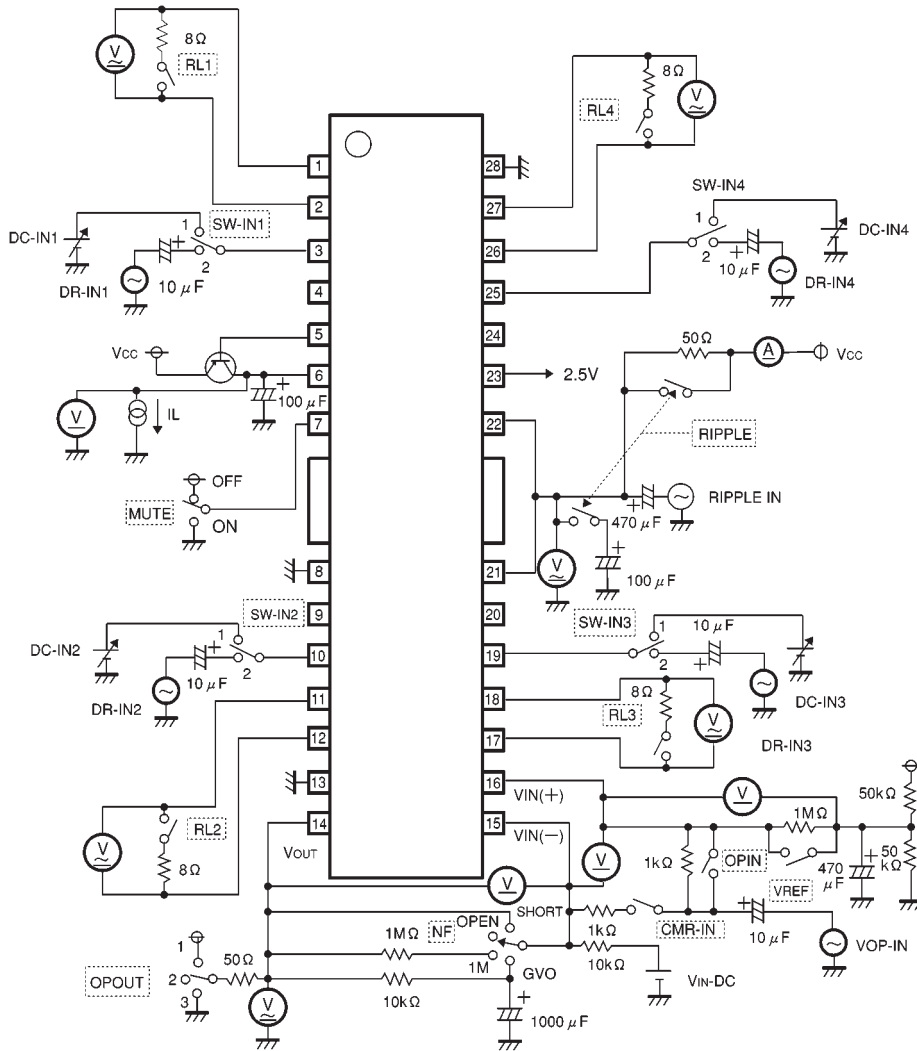

Fig.1

● Measurement circuit switch table

Parameter	Switch										Input				Condition	
	RIPPLE	MUTE	RL	OPIN	VREF	CMR-IN	NF	OPOUT	SW-IN	DR-IN	DC-IN	RIPPLEIN	VOPIIN	VINDC		
Driver	Quiescent current dissipation	ON	OFF	OFF	ON	ON	OFF	SHORT	2	2	0	0	0	0	OFF	Only one channel on at a time
	Output offset voltage	↓	↓	ON	↓	↓	↓	↓	↓	1	↓	2.5V	↓	↓	↓	
	Maximum output amplitude	↓	↓	↓	↓	↓	↓	↓	↓	↓	↓	0V,5V	↓	↓	↓	
	Closed loop voltage gain	↓	↓	↓	↓	↓	↓	↓	↓	2	0.1V _{rms}	0	↓	↓	↓	
	Ripple rejection	OFF	↓	↓	↓	↓	↓	↓	↓	1	0	2.5V	0.1V _{rms}	↓	↓	
Regulator	Slew rate	ON	↓	↓	↓	↓	↓	↓	2	⌋	0	0	↓	↓		
	Output voltage	↓	↓	OFF	↓	↓	↓	↓	↓	0	↓	↓	↓	↓	↓	
	Output load variation	↓	↓	↓	↓	↓	↓	↓	↓	↓	↓	↓	↓	↓	↓	
	Supply voltage variation	↓	↓	↓	↓	↓	↓	↓	↓	↓	↓	↓	↓	↓	↓	
Operational amplifier	Offset voltage	↓	↓	↓	↓	↓	↓	↓	↓	↓	↓	↓	↓	↓	↓	
	Input bias current	↓	↓	↓	↓	OFF	↓	1M	↓	↓	↓	↓	↓	↓	↓	
	Output high level voltage	↓	↓	↓	↓	ON	↓	OPEN	↓	↓	↓	↓	↓	↓	2V	
	Output low level voltage	↓	↓	↓	↓	↓	↓	↓	↓	↓	↓	↓	↓	↓	6V	
	Output driver current (sink)	↓	↓	↓	↓	↓	↓	SHORT	1	↓	↓	↓	↓	↓	OFF	
	Output driver current (source)	↓	↓	↓	↓	↓	↓	↓	3	↓	↓	↓	↓	↓	↓	
	Open loop voltage gain	↓	↓	↓	↓	↓	↓	GVO	↓	↓	↓	↓	↓	-75dBV	↓	
	Slew rate	↓	↓	↓	↓	↓	↓	SHORT	↓	↓	↓	↓	↓	⌋	↓	
Ripple rejection	OFF	↓	↓	↓	↓	↓	↓	↓	↓	↓	↓	0.1V _{rms}	0	↓		
Common mode rejection ratio	ON	↓	↓	OFF	OFF	ON	1M	↓	↓	↓	↓	0	0.1V _{rms}	↓		

● Input/output circuits

Driver input

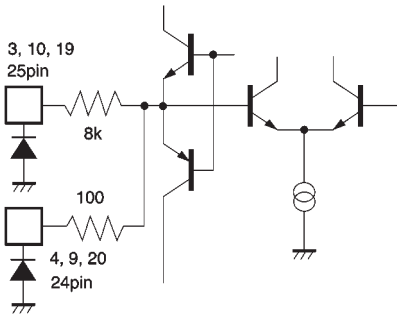

Bias

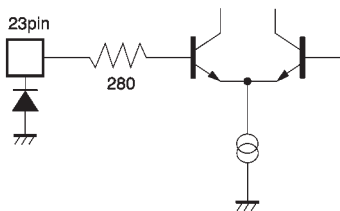

Driver output

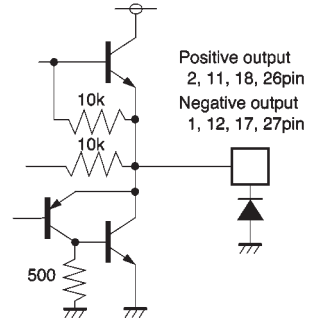

Regulator (base connection)

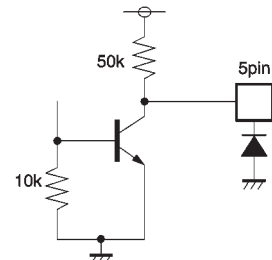

Mute

Regulator output

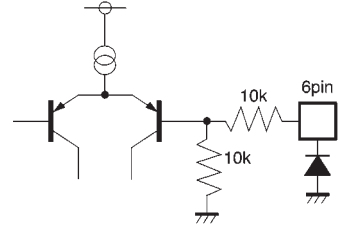
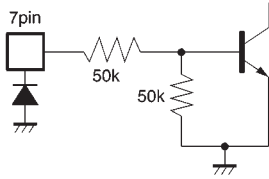

Operational amplifier input

Operational amplifier output

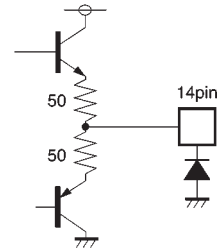
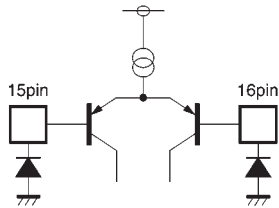

Fig. 2

● Application example

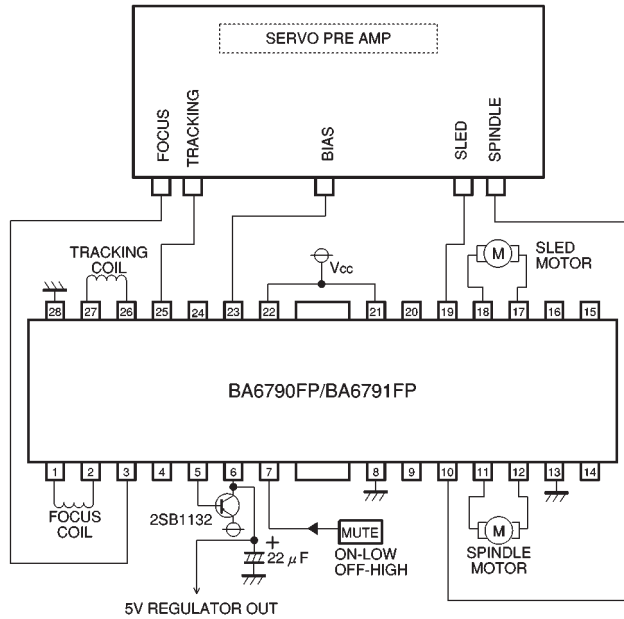
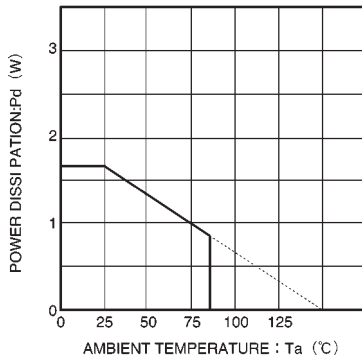

Fig.3

● Thermal derating curve



When mounted on a 50 mm × 50 mm × 1.6 mm board

Fig. 4

● Operation notes

- (1) The BA6790FP and BA6791FP have an internal thermal shutdown circuit. Output current is muted when the chip temperature exceeds 175°C (typically) and restored when the chip temperature falls to 150°C (typically).
- (2) If the mute pin (pin 7) voltage is opened or lowered below 0.5V, the output current will be muted. Pin 7 should be pulled up above 2.0V during normal use.
- (3) The bias pin (pin 23) is muted when lowered below 1.4V (typically). Make sure it stays above 1.6V during normal use.
- (4) Muting occurs during thermal shutdown, mute-on operations or a drop in the bias pin voltage. In each case, only the drivers are muted. During muting, the output pins remain at the internal bias voltage, roughly ($V_{CC}/2$).
- (5) Be sure to connect the IC to a 0.1μF bypass capacitor to the power supply, at the base of the IC.
- (6) The radiating fin is connected to the packages internal GND, but should also be connected to an external ground.
- (7) The capacitor between regulator output (pin 6) and GND also serves to prevent oscillation of the IC, so select one with good temperature characteristics.

● External dimensions (Units: mm)

