

5ch Power Driver for CD-ROM, DVD-ROM

BD7904FS

BD7904FS is a 5-channel driver IC that integrates all drivers and 3.3V regulator necessary for CD-ROM, and DVD-ROM systems into a single chip. Low head operation can be achieved by applying the PWM driving system for sled and spindle motor drivers.

●Applications

CD-ROM, DVD-ROM

●Features

- 1) 3channel BTL driver, 1channel PWM driver and 3phase motor driver.
- ALL of the motor and actuator for CD-ROM, DVD-ROM etc.
- 2) ON/OFF for each driver, brake mode switching of spindle, and stand-by mode switching can be controlled by the two control terminals.
- 3) Built-in triangular-wave generator.
- 4) SSOP-A54 for strong head radiation.
- 5) Built in thermal-shut-down circuit.
- 6) FG 3phase synthetic output.

●Absolute maximum ratings (Ta=25°C)

Parameter	Symbol	Limits	Unit
POWER MOS power supply voltage	SPVM1,2,SLRNF	15*1	V
Preblock/BTL powerblock power supply voltage	Vcc,SLVDD,AVM	15	V
PWM control block, REG power supply voltage	DVcc	7	V
Power dissipation	Pd	2.6*2	W
Operating temperature range	Topr	-35~+85	°C
Storage temperature	Tstg	-55~+150	°C

*1 POWER MOS output terminals (10, 11, 18, 47, 48pin) is contained.

*2 PCB (70mm×70mm×1.6mm glass epoxy) mounting.

Reduced by 20.8mW for each increase in Ta of 1°C over 25°C.

Optical disc ICs

●Recommended operating conditions (Ta=25°C)

(Set the power supply voltage taking allowable dissipation into considering)

Parameter	Symbol	Min.	Typ.	Max.	Unit
POWER MOS Power supply voltage 1	SPVM1, 2	-	V _{CC} *3	-	V
POWER MOS Power supply voltage 2	SLRNF	-	SLVDD*3	-	V
Preblock Power supply voltage	SLVDD, V _{CC}	AVM	12	14	V
Power block Power supply voltage	AVM	4.3	5.0	V _{CC}	V
PWM control block, REG Power supply voltage	DV _{CC}	4.3	5.0	6.0	V
Spindle output current	lo _{sp}	-	1.0	2.5*4	A
SL/FO/TR/LO output current	lo _o	-	0.5	0.8	A

*3 Set the same supply voltage to V_{CC} and SPVM1, 2 to SLVDD and SLRNF.

*4 The current is guaranteed 3.0A in case of the current is turned on/off in a duty-ratio of less than 1/10 with a maximum on-time of 5msec.

●Block diagram

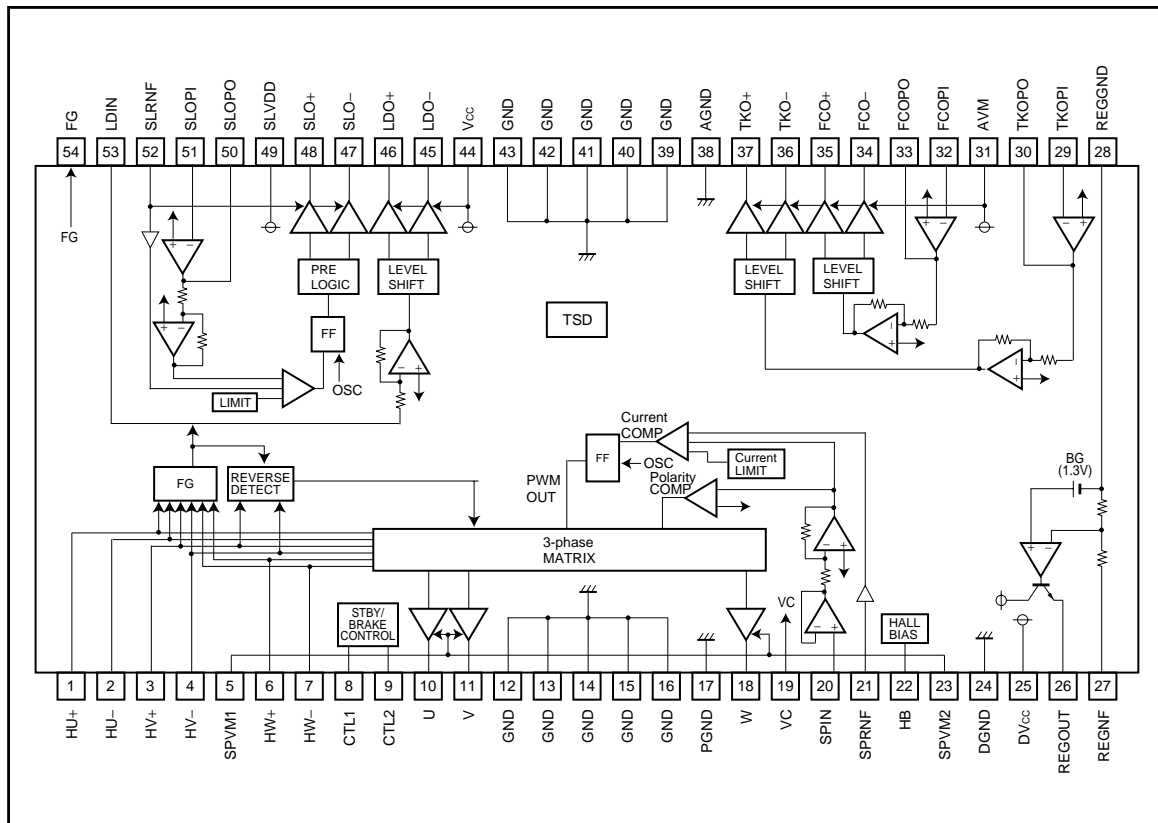

Optical disc ICs

●Pin descriptions

Pin No.	Pin name	Function	Pin No.	Pin name	Function
1	HU+	Hall amp. U positive input	28	REGGND	Regulator block ground
2	HU-	Hall amp. U negative input	29	TKOPI	Tracking driver OP-AMP-input
3	HV+	Hall amp. V positive input	30	TKOPO	Tracking driver OP-AMP output
4	HV-	Hall amp. V negative input	31	AVM	Actuator driver block power supply
5	SPVM1	Spindle driver power supply 1	32	FCOPI	Focus driver OP-AMP-input
6	HW+	Hall amp. W positive input	33	FCOPO	Focus driver OP-AMP output
7	HW-	Hall amp. W negative input	34	FCO-	Focus driver negative output
8	CTL1	Driver logic control input 1	35	FCO+	Focus driver positive output
9	CTL2	Driver logic control input 2	36	TKO-	Tracking driver negative output
10	U	Spindle driver output U	37	TKO+	Tracking driver positive output
11	V	Spindle driver output V	38	AGND	Ground
12	GND	GND	39	GND	GND
13	GND	GND	40	GND	GND
14	GND	GND	41	GND	GND
15	GND	GND	42	GND	GND
16	GND	GND	43	GND	GND
17	PGND	Spindle driver power ground	44	V _{cc}	BTL pre and Loading power supply
18	W	Spindle driver output W	45	LDO-	Loading driver negative output
19	VC	Reference voltage input	46	LDO+	Loading driver positive output
20	SPIN	Spindle driver input	47	SLO-	Sled driver negative output
21	SPRNF	Spindle driver current sense	48	SLO+	Sled driver positive output
22	HB	Hall bias	49	SLVDD	Sled driver PowerMOS pre-supply
23	SPVM2	Spindle driver power supply 2	50	SLOPO	Sled driver OP-AMP output
24	DGND	PWM block pre-ground	51	SLOPI	Sled driver OP-AMP- input
25	DV _{cc}	PWM block control power supply	52	SLRNF	Sled driver current sense
26	REGOUT	Regulator output voltage pin	53	LDIN	Loading driver input
27	REGNF	Regulator return pin	54	FG	Frequency generator output

* Positive/negative of the output terminals are determined in reference to those of the input terminals.

Optical disc ICs

●Input output circuit

Three-phase motor driver output	Spindle driver current detection input	Hall bias
Hall signal input		FG signal output
PWM driver output SLED	BTL driver output FO, TK	BTL driver output LD
BTL driver input FO, TK	PWM driver input SLED1, 2	PWM driver input Spindle

Optical disc ICs

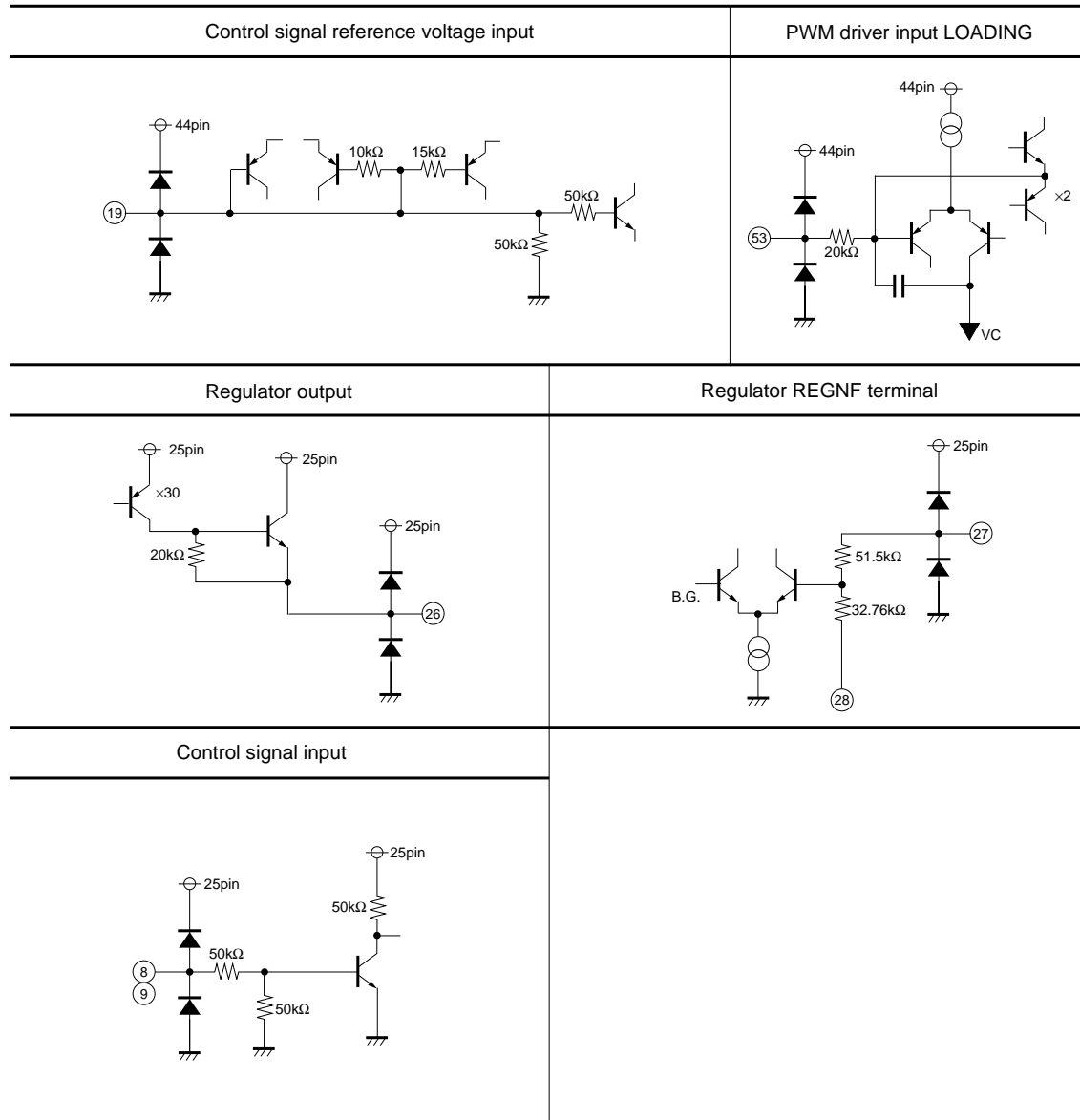

Optical disc ICs

●Electrical characteristics

(unless otherwise noted, Ta=25°C, SLVDD=V_{CC}=12V, DV_{CC}=AVM=5V, VC=1.65V, SPRNF=0.33Ω, SLRNF=0.5Ω)

Parameter	Symbol	Min.	Typ.	Max.	Unit	Conditions	Circuit
Circuit current							
Quiescent current 1	IQ1	–	11	19	mA	V _{CC} (Loading OFF)	Fig1, 2
Quiescent current 2	IQ2	–	9.5	16	mA	V _{CC} (Loading ON)	Fig1, 2
Quiescent current 3	IQ3	–	3.5	6.5	mA	DV _{CC}	Fig1, 2
Standby-on current 1	IST1	–	2.2	3.7	mA	V _{CC}	Fig1, 2
Standby-on current 2	IST2	–	0.65	1.0	mA	DV _{CC}	Fig1, 2
Spindle driver block (Hall bias)							
Hall bias voltage	VHB	0.7	1.2	1.6	V	IHB=10mA	Fig1, 2
Spindle driver block (Hall amplifier)							
Input bias current	IHIB	–	1	5	μA		Fig1, 2
Minimum input level	VHIM	50	–	–	mV _{PP}		Fig1, 2
Common mode input Range	VHICM	1	–	4	V		Fig1, 2
Spindle driver block (Torque control)							
Input dead zone (one side)	VDZSP	20	50	90	mV		Fig1, 2
Input output gain	gmSP	2.4 (0.8)	3.0 (1.0)	3.6 (1.2)	A/V (V/V)	SPRNF=0.33Ω	Fig1, 2
Output ON resistor (upper)	RONUSP	–	0.6	1.0	Ω	I _p =500mA	
Output ON resistor (lower)	RONLSL	–	0.35	0.7	Ω	I _o =500mA	Fig1, 2
Output limit current	ILIMSL	0.74 (0.24)	0.95 (0.31)	1.16 (0.38)	A (V)	SPRNF=0.33Ω	Fig1, 2
PWM frequency	fosc	–	100	–	kHz		Fig1, 2
Spindle driver block (FG output)							
High voltage	VFGH	–	4.9	–	V	100kΩ pull up to DV _{CC}	Fig1, 2
Low voltage	VFGL	–	0.1	–	V		Fig1, 2
Sled driver block							
Input dead zone (one side)	VDZSL	0	10	40	mV		Fig1, 2
Input output gain	gmSL	0.8 (0.4)	1.0 (0.5)	1.2 (0.6)	A/V (V/V)	SLRNF=0.5Ω	Fig1, 2
Output ON resistor (upper)	RONUSL	–	1.5	2.0	Ω	I _o =500mA	Fig1, 2
Output ON resistor (lower)	RONLSL	–	0.9	1.4	Ω	I _o =500mA	
Output limit current	ILIMSL	0.48 (0.24)	0.62 (0.31)	0.76 (0.38)	A (V)	SLRNF=0.5Ω	Fig1, 2
PWM frequency	fosc	–	100	–	kHz		Fig1, 2
Actuator driver block							
Output offset voltage	VOFFT	–50	0	50	mV		Fig1, 2
Output saturation voltage "H"	VOHFT	–	0.45	0.8	V	I _o =500mA	Fig1, 2
Output saturation voltage "L"	VOLFT	–	0.45	0.8	V	I _o =500mA	Fig1, 2
Voltage gain	GVFT	16.0	17.5	19.0	dB		Fig1, 2

© This product is not designed for protection against radioactive rays.

Optical disc ICs

Parameter	Symbol	Min.	Typ.	Max.	Unit	Conditions	Circuit
Sled/Actuator driver pre-operational amplifier block							
Input offset voltage	VOFOP	-6	0	6	mV		Fig1, 2
Input bias current	IBOP	-	20	300	nA		Fig1, 2
Common mode input range	VICM	0.4	-	10.8 (4.0)	V	() : Sled block	Fig1, 2
Output source current	IOSOOP	0.3	-	-	mA		Fig1, 2
Output sink current	IOSIOP	3	-	-	mA		Fig1, 2
"H" level output voltage	VOHOP	11.5 (4.5)	11.9 (4.9)	-	V	() : Sled block	Fig1, 2
"L" level output voltage	VOLOP	0	0.1	0.4	V		Fig1, 2
Loading driver block							
Output offset voltage	VOFLD	-50	0	50	mV		Fig1, 2
Output saturation voltage "H"	VOHLD	-	1.1	1.4	V	Io=500mA	Fig1, 2
Output saturation voltage "L"	VOLL	-	0.45	0.8	V	Io=500mA	Fig1, 2
Voltage gain	GVLD	16.0	17.5	19.0	dB		Fig1, 2
Regulator block							
ROUT pin output voltage	VREG	3.13	3.3	3.47	V		Fig1, 2
Peak output current	IorMax	-	-	500	mA		Fig1, 2
Load regulation	Δ VRL	-	10	30	mV	Ireg=100mA, VROUT=3.3V	Fig1, 2
Line regulation	Δ VVcc	-	3	10	mV	DVcc=4.5~5.5V	Fig1, 2
CTL1, CTL2							
Input high voltage	VIH	2.0	-	-	V		Fig1, 2
Input low voltage	VIL	-	-	0.5	V		Fig1, 2
Others							
VC drop-muting	VMVC	0.4	0.7	1.0	V		Fig1, 2
Vcc drop-muting	VMVcc	3.4	3.8	4.2	V		Fig1, 2

© This product is not designed for protection against radioactive rays.

Optical disc ICs

● Measurement circuits

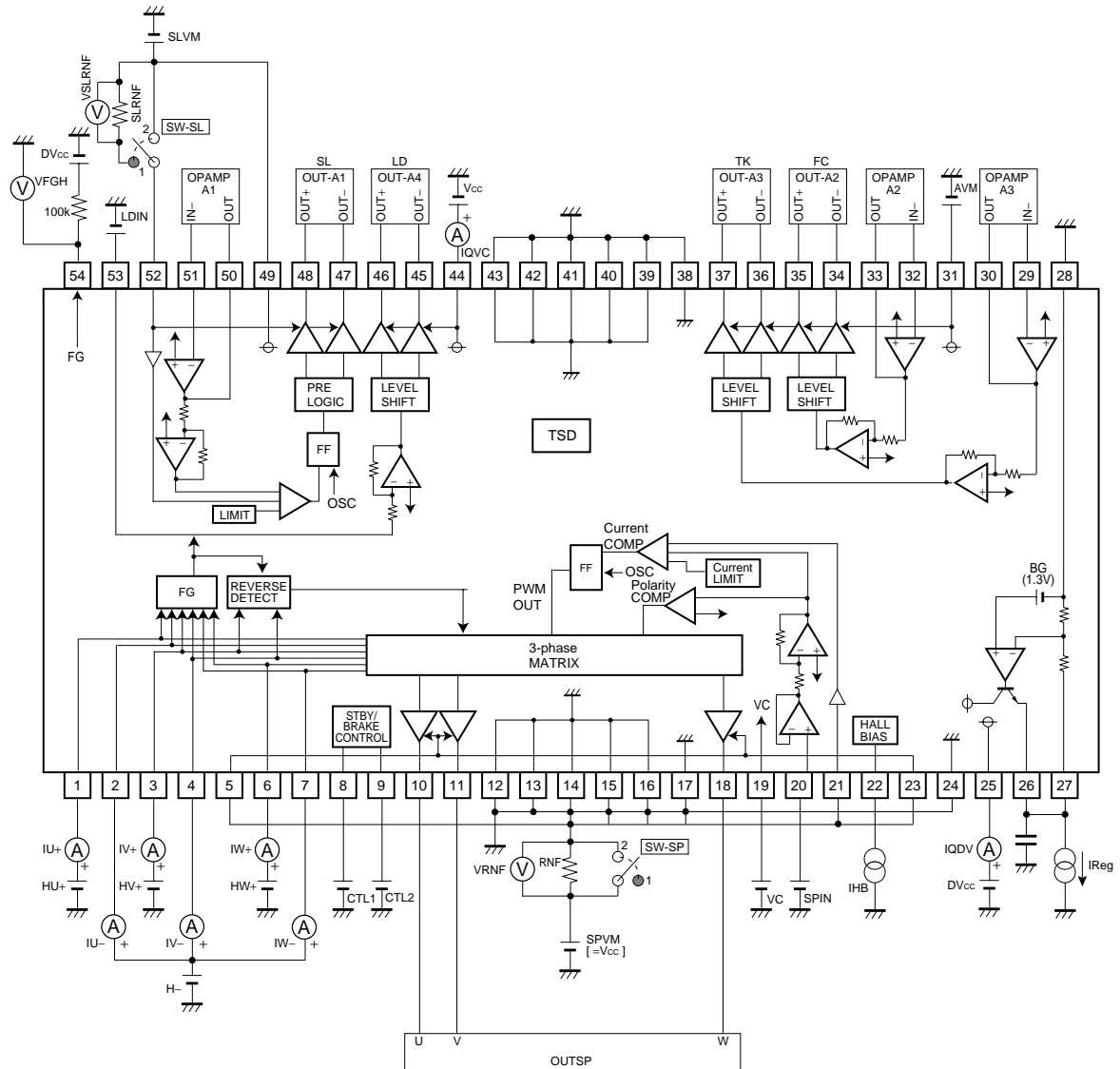

Fig.1

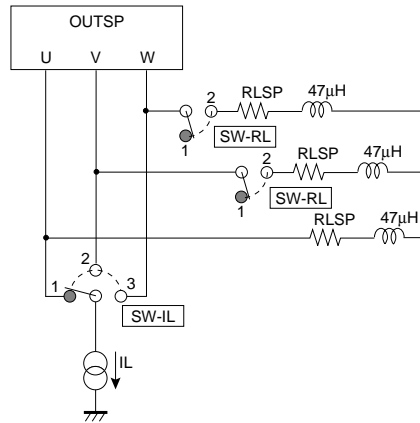
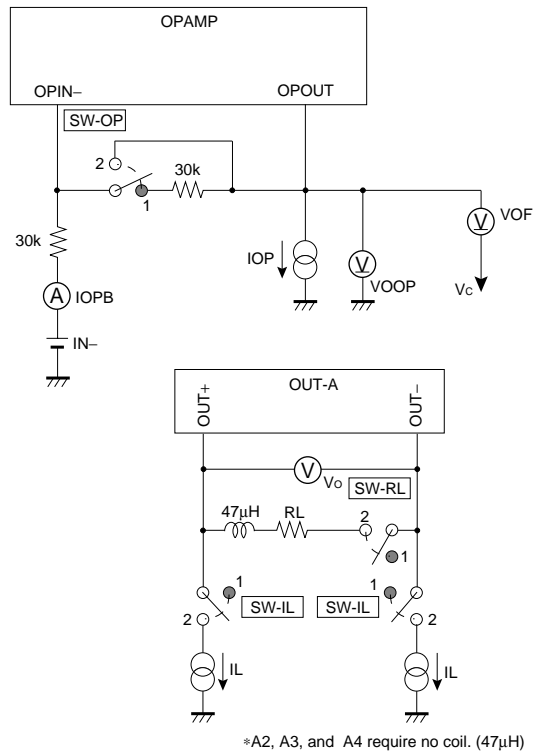

Fig.2

Optical disc ICs

●Table of measure circuit switches position 1

(V_{CC}=SPVM=SLVM=12V, DV_{CC}=AVM=5V, VC=1.65V, RL (act) =8Ω, RL (SL) =8Ω+47μH, RL (SP) =2Ω+47μH, SLRNF=0.5Ω, SPRNF=0.33Ω, H₋=2.5V, HU₊=2.6V, HV₊=HW₊=2.4V)

Designation	INPUT	CTL		SWITCH					Conditions	Measure point
	VIN	1	2	RL	SP	SL	IL	OP		
Circuit current										
IQ1	-	L	H	1	1	1	1	1		IQVC
IQ2	-	H	L	1	1	1	1	1		IQVC
IQ3	-	L	H	1	1	1	1	1		IQDV
IST1	-	L	L	1	1	1	1	1		IQVC
IST2	-	L	L	1	1	1	1	1		IQDV
Sled driver block										
VDZSL	*1	H	H	2	1	1	1	1	*1 Check VSLRNF with no output at VIN=VC Check VSLRNF with output at VIN=VC±40mV	VSLRNF
gmSL	*2	H	H	2	1	1	1	1	See bellow	VSLRNF
RONUSL	3.3V (0V)	H	H	1	1	2	2	1	ILSL=500mA $RON = \frac{12V - VOSL + (-)}{0.5A}$	OUT+ (-)
RONLSL	0V (3.3V)	H	H	1	1	2	2	1	ILSL=-500mA $RON = \frac{VOSL + (-)}{0.5A}$	OUT+ (-)
ILIMSL	3.3V (0V)	H	H	2	1	1	1	1		VSLRNF
fosc	1.45	H	H	2	1	1	1	1		VOSL+

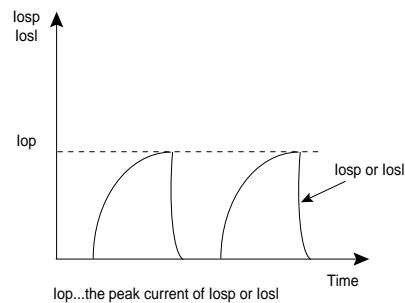
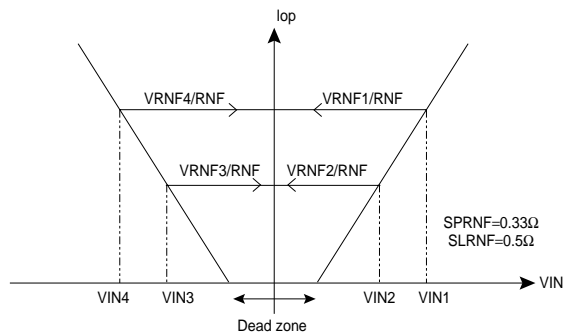

*2 Sled driver

VIN1=240mV, VIN2=140mV
VIN3=-140mV, VIN=-240mV

$$gm (+) = \left(\frac{VSLRNF1 - VSLRNF2}{240mV - 140mV} \right) / 0.5\Omega$$

$$gm (-) = \left(\frac{VSLRNF4 - VSLRNF3}{240mV - 140mV} \right) / 0.5\Omega$$

*4 Spindle driver

VIN1=150mV, VIN2=100mV
VIN3=-100mV, VIN=-150mV

$$gm (+) = \left(\frac{VSPRNF1 - VSPRNF2}{150mV - 100mV} \right) / 0.33\Omega$$

$$gm (-) = \left(\frac{VSPRNF4 - VSPRNF3}{150mV - 100mV} \right) / 0.33\Omega$$

Optical disc ICs

●Table of measure circuit switches position 2

($V_{CC}=SPVM=SLVM=12V$, $DV_{CC}=AVM=5V$, $V_C=1.65V$, $R_L(\text{act})=8\Omega$, $R_L(\text{SL})=8\Omega+47\mu\text{H}$, $R_L(\text{SP})=2\Omega+47\mu\text{H}$,
 $SLRNF=0.5\Omega$, $SPRNF=0.33\Omega$, $H=-2.5V$, $HU+=2.6V$, $HV+=HW+=2.4V$)

Designation	INPUT	CTL		SWITCH					Conditions	Measure point
	VIN	1	2	RL	SP	SL	IL	OP		
Spindle driver block										
〈 Hall bias 〉										
VHB	1.65V	H	H	1	1	1	1	1	IHB=10mA	Pin 22
〈 Hall amplifier 〉										
IHIB	1.65V	H	H	1	1	1	1	1	Current flowing in each terminal at $H=-2.5V$, $HW+=2.7V$ (2.3V), $HV=2.5V$	IU+ (-), IV+ (-), IW+ (-)
〈 Torque command 〉										
VDZSP	*3	L	H	2	1	1	1	1	*2 Check VRNF with no output at $VIN=VC\pm 20mV$ Check VRNF with output at $VIN=VC\pm 90mV$	VSPRNF
gmSP	*4	L	H	2	1	1	1	1	See 10 of 18 previous page	VSPRNF
RONUSP	3.3V	H	H	1	2	1	2	1	ILSP=500mA $RON = \frac{12V - VOSP}{0.5A}$	OUTU, V, W
RONLSP	3.3V	H	H	1	2	1	2	1	ILSP=-500mA $RON = \frac{VOSP}{0.5A}$	OUTU, V, W
ILIMSP	3.3V	H	H	2	1	1	1	1		VSPRNF
fosc	1.85	H	H	2	1	1	1	1		VOSPU
〈 FG 〉										
VFGH	1.65V	H	H	1	1	1	1	1	HU+=2.6V, HV+=2.4V, HW+=2.4V	VFG
VFGL	1.65V	H	H	1	1	1	1	1	HU+=2.6V, HV+=2.6V, HW+=2.4V	VFG

*5 Condition of input

HU+	HV+	HW+	U	V	W	Condition	Measure point
2.4V	2.6V	2.6V	Source	Hi-Z	Sink	IOSPU=500mA	VOSPU
2.6V	2.4V	2.6V	Sink	Source	Hi-Z	IOSPV=500mA	VOSPV
2.6V	2.6V	2.4V	Hi-Z	Sink	Source	IOSPW=500mA	VOSPW
2.6V	2.4V	2.4V	Sink	Hi-Z	Source	IOSPU=-500mA	VOSPU
2.4V	2.6V	2.4V	Source	Sink	Hi-Z	IOSPV=-500mA	VOSPV
2.4V	2.4V	2.6V	Hi-Z	Source	Sink	IOSPW=-500mA	VOSPW

Optical disc ICs

●Table of measure circuit switches position 3

(V_{CC}=SPVM=SLVM=12V, DV_{CC}=AVM=5V, VC=1.65V, RL (act) =8Ω, RL (SL) =8Ω+47μH, RL (SP) =2Ω+47μH, SLRNF=0.5Ω, SPRNF=0.33Ω, H₋=2.5V, HU₊=2.6V, HV₊=HW₊=2.4V)

Designation	INPUT	CTL		SWITCH					Conditions	Measure point
	VIN	1	2	RL	SP	SL	IL	OP		
Actuator driver block										
VOFFT	1.65V	H	H	2	1	1	1	1		VO
VOHFT	3.3V (0V)	H	H	1	1	1	2	1	IL=500mA	5-OUT+ (-)
VOLFT	0V (3.3V)	H	H	1	1	1	2	1	IL=-500mA	OUT+ (-)
GVFT	±0.25V	H	H	2	1	1	1	1	20log (VO - VOFFT) / ±0.25	VO
Loading driver block										
VOFLD	1.65V	H	L	2	1	1	1	1		VO
VOHLD	3.3V (0V)	H	L	1	1	1	2	1	IL=500mA	12-OUT+ (-)
VOLL	0V (3.3V)	H	L	1	1	1	2	1	IL=-500mA	OUT+ (-)
GVLD	±0.25V	H	L	2	1	1	1	1	20log (VO - VOFFT) / ±0.25	VO
Pre-operational amplifier block										
VOFOP	-	H	H	1	1	1	1	2		VOF
IBOP	1.65V	H	H	1	1	1	1	2		IOPB
IOSOOP	-	H	H	1	1	1	1	2	IOP=320μA	VOF
IOSIOP	-	H	H	1	1	1	1	2	IOP=-4mA	VOF
VOHOP	0V	H	H	1	1	1	1	1		VOOP
VOLOP	5V	H	H	1	1	1	1	1		VOOP
Regulator block										
VREG	-	H	H	1	1	1	1	1		Pin27
IorMax	-	H	H	1	1	1	1	1		Pin27
ΔVRL	-	H	H	1	1	1	1	1	Ireg=100mA	Pin27
ΔVV _{CC}	-	H	H	1	1	1	1	1	DV _{CC} =4.5V~5.5V	Pin27
CTL1, CTL2										
VIH	1.65V	L	L	2	1	1	1	1	Check active at "H"=2.0	IQVC
VIL	1.65V	H	H	2	1	1	1	1	Check stand-by at "L"=0.5	IQVC
Others										
VMVC	1.65V	H	H	1	1	1	1	1	Check all output at VC=0.7V	OUTPUT
VMV _{CC}	1.65V	H	H	1	1	1	1	1	Check all output at V _{CC} =3.8V	OUTPUT

Optical disc ICs

●Circuit operation

1. Driver control terminal 1 and 2 (pin 8 and pin 9)

All the drivers and spindle-drive braking mode can be switched on/off by inputting combinations of H-level signal (higher than 2V) and L-level signal (lower than 0.5V) to these terminals.

CTL1 (Pin8)	CTL2 (Pin9)	Spindle	Sled	Focus	Tracking	Loading	Regulator	
L	L	×	×	×	×	×	○	1)
H	L	×	×	×	×	○	○	2)
-	H	○	○	○	○	×	○	

○ ... ON × ... OFF

CTL1 (Pin8)	CTL2 (Pin9)	SPIN > VC	SPIN < VC	
L	H	Forward-rotation mode	Reverse-rotation braking mode	3)
H	H	Forward-rotation mode	Short-circuit braking mode	4)

1) Standby mode

All blocks except for the regulator are standby-mode.

2) Drivers muting

All the output channels except the loading are muted and there outputs are turn off.

3) Reverse-rotation braking mode (spindle)

A reverse-rotation torque is applied when SPIN < VC.

Reverse-rotation is detected with SPIN input and Hall input. If the spindle detects reverse rotation when SPIN < VC, all the outputs are shorted out to GND.

4) Short-circuit braking mode (spindle)

All the spindle driver outputs are shorted out to GND when SPIN < VC.

5) Regulator

Regulator actives in all the mode.

Optical disc ICs

2. Input/output timing chart

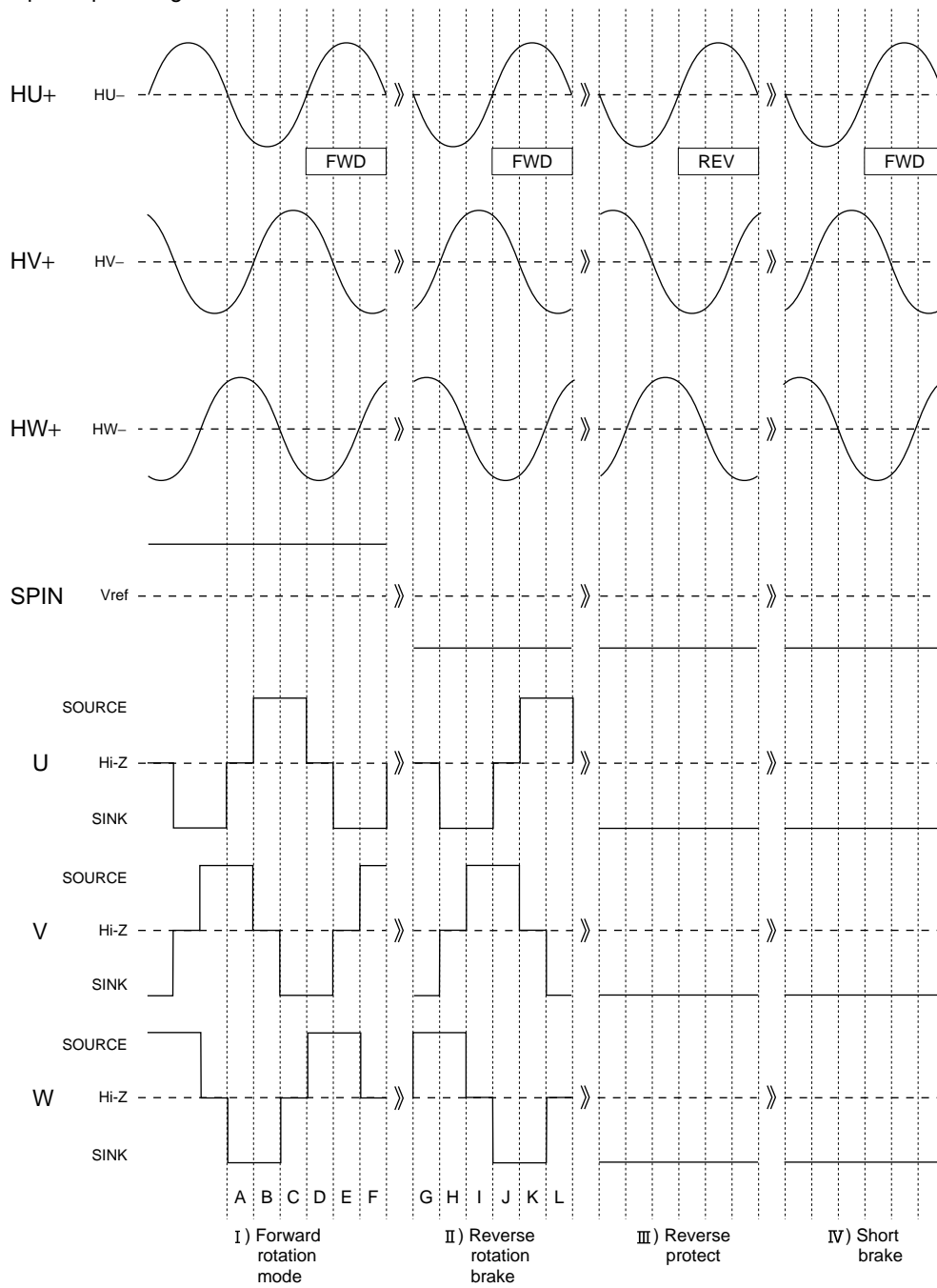

Optical disc ICs

I) Forward-rotation mode

In this mode, the disc rotation is started and accelerated.

When forward-rotation signal inputs from the Hall elements to the positive spindle-drive input terminals (SPIN > V_c), the spindle-drive output terminals output forward torque signal.

	Hall amplifier input (forward rotation)						SPIN > V _c		
	HU+	HU-	HV+	HV-	HW+	HW-	U	V	W
A	L	H	L	H	H	L	Hi-Z	Source	Sink
B	L	H	H	L	H	L	Source	Hi-Z	Sink
C	L	H	H	L	L	H	Source	Sink	Hi-Z
D	H	L	H	L	L	H	Hi-Z	Sink	Source
E	H	L	L	H	L	H	Sink	Hi-Z	Source
F	H	L	L	H	H	L	Sink	Source	Hi-Z

Source=PWM

II, III) Braking mode

In this mode, the disc rotation is decelerated and stopped.

< Reverse-rotation braking >

When the forward-rotation signal inputs from the Hall elements to the negative spindle-drive input terminals (SPIN < V_c), the spindle-drive output terminals output reverse torque signal.

	Hall amplifier input (forward rotation)						SPIN < V _c		
	HU+	HU-	HV+	HV-	HW+	HW-	U	V	W
G	L	H	L	H	H	L	Hi-Z	Sink	Source
H	L	H	H	L	H	L	Sink	Hi-Z	Source
I	L	H	H	L	L	H	Sink	Source	Hi-Z
J	H	L	H	L	L	H	Hi-Z	Source	Sink
K	H	L	L	H	L	H	Source	Hi-Z	Sink
L	H	L	L	H	H	L	Source	Sink	Hi-Z

Source=PWM

3. Hall inputs (pin 1 to 4, 6, 7) and Hall bias (pin 22) (Spindle)

Hall elements can be connected either in series or in parallel. Set the Hall input voltage to 1.0 to 4.0V.

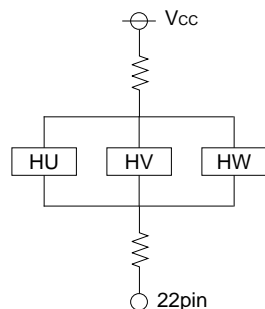

< Parallel connection >

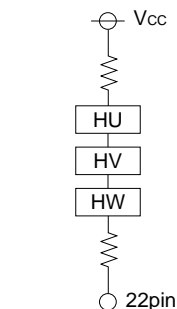

< Series connection >

Optical disc ICs

4. Torque command (spindle: pin 20, sled motor: pin 50) / output current detection terminals (spindle: pin 21, sled motor: pin 52)

The relation between the torque command input and the output current detection terminals input is expressed as shown below:

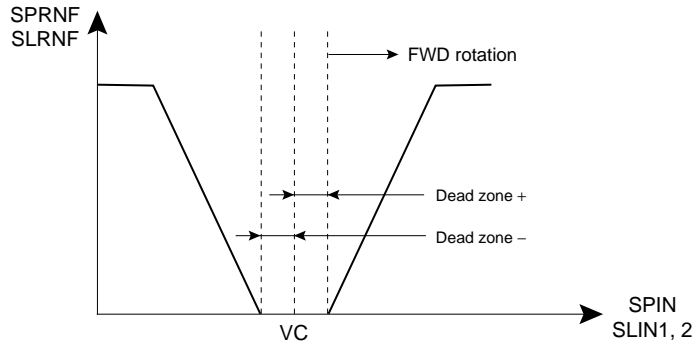

The input-output gain (gm) and the output-limit current (ILIM) depend on the resistance of RNF (output current detection resistor). Please refer to the following expression.

The gain to drive the spindle or the sled motor can be decreased by connecting a resistor in series to each input terminal.

● Gain expression

	Spindle	Sled
Input-output gain gm (A/V)	1.0/RNF	0.5/RNF
Output-limit current Ilim (A)	0.3/RNF	0.3/RNF
Gain with the added resistor gm (A/V)	$15k / \{SPRNF \times (Rin + 15k)\}$	$0.5 \times 47k / \{SLRNF \times (Rin + 47k)\}$

Rin : added series resistor

5. PWM oscillation frequency

The PWM oscillation for driving the spindle and sled is free running. The oscillating frequency is 100kHz (typ.).

6. Regulator

3.3V is possible by connecting REGNF (27 pin) with REGOUT (26 pin).

And, adjust by your inserting resistance when you use it in other voltage.

$$OUT1 = BG \{ R1 (R2 + R3 + R4) + R2 (R3 + R4) \} / R2R4$$

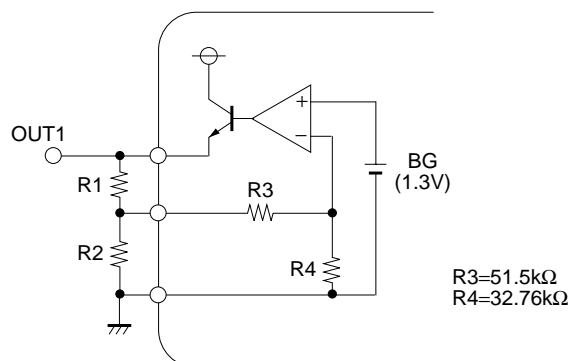

Optical disc ICs

7. Muting functions

a) VC-drop muting

When the voltage at VC terminal (pin 19) drops to a value lower than 0.7V (typ.), the outputs of all the channels are turned off. Set the VC terminal voltage to larger than 1.0V.

b) V_{CC}-drop muting

When the voltages at DV_{CC} terminal (pin 25) and V_{CC} terminal (pin 44) drop to lower than 3.8V (typ.), the outputs of all the channels are turned off. The hysteresis voltage width is 80mV (typ.).

8. Thermal-shutdown

A thermal-shutdown circuit (over-temperature protection circuit) is built in to prevent the IC from thermal breakdown. Use the IC under the thermal loss allowed to the package. In case the IC is left running over the allowable loss, the junction temperature rises, and the thermal-shutdown circuit works at the junction temperature of 175°C (typ.) (the outputs of all the channels are turned off). When the junction temperature drops to 150°C (typ.), the IC start operating again.

●Application example

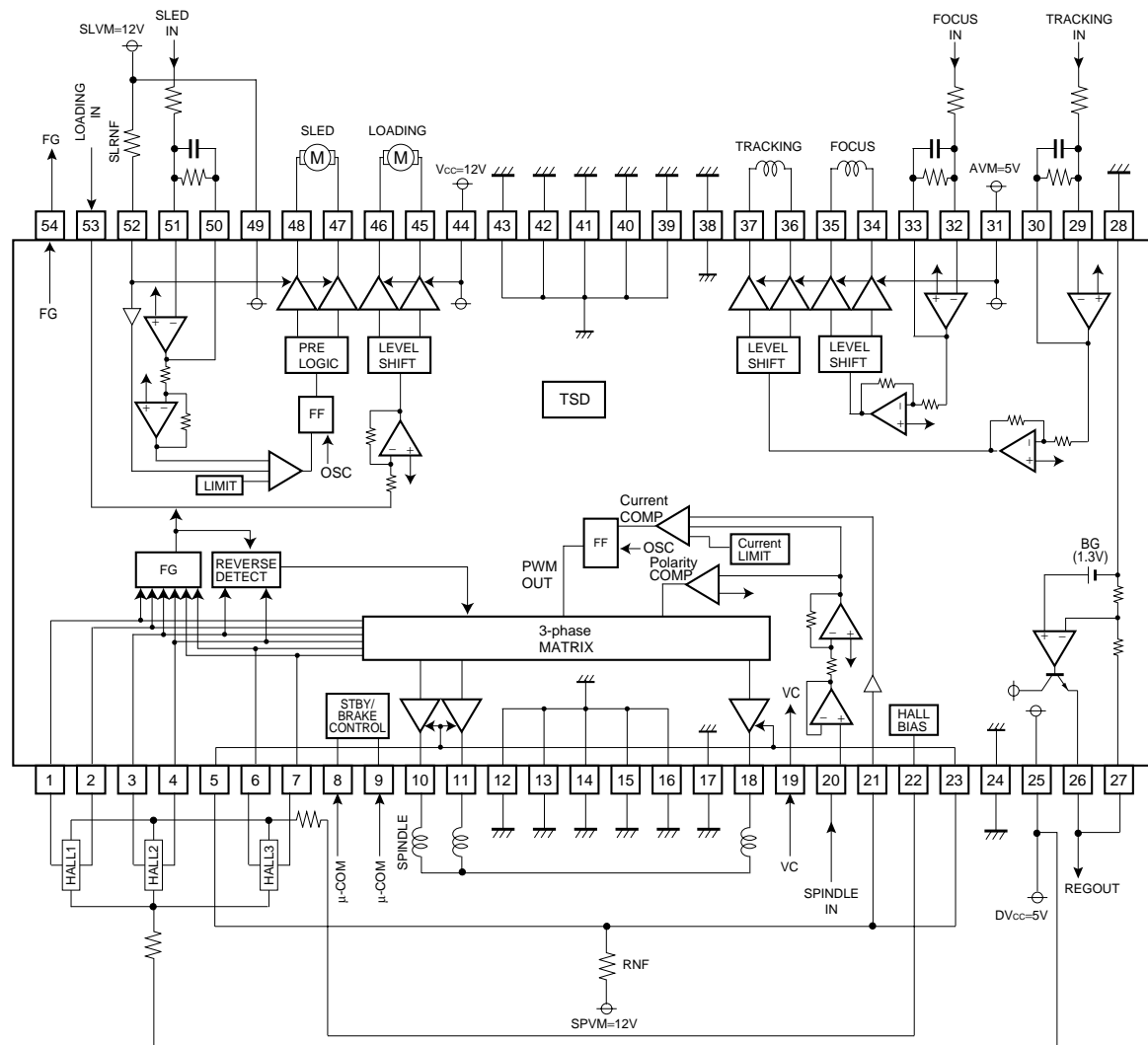

Fig.3

Optical disc ICs

●Operation notes

(1) Wiring for SPRNF and SLRNF

Considering the wiring resistance, connect each detecting resistor as close as possible to the current detection terminals for the spindle drive SPRNF (pin 21) and the sled motor drive SLRNF (pin 52) of the IC.

(2) Current detection reference voltage

The detection of current in the spindle and sled involves the detection of voltage between the detection resistances, but as the reference voltage of internal circuit, the voltage applied to V_{CC} (pin 44) is used by the spindle and that applied to $SLVDD$ (pin 49) by the sled.

For this reason, be sure to apply V_{CC} (pin 44) to the spindle and $SLVDD$ (pin 49) to the sled according to the corresponding power supply voltages to prevent voltage differences.

(3) Bypass capacitor

Please connect a bypass capacitor (1 μ F) across the supply voltage lines close to the IC pins.

(4) Supply fault, ground fault, and short-circuit between output terminals

Do not short-circuit between any output pin and supply pin (supply fault) or ground (ground fault), or between any output pins (load short-circuit). When mounting the IC on the circuit board, be extremely cautious about the orientation of the IC. If the orientation is mistaken, the IC may break down, and produce smoke in some cases.

●Electrical characteristic curves

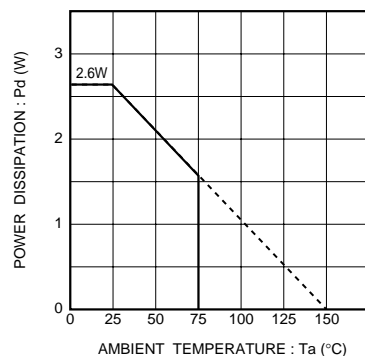

* On less than 25.7% (percentage occupied by copper foil),
70x70mm², t=1.6mm glass epoxy mounting.

Fig.4 Power dissipation

●External dimensions (Units : mm)

