



## SBS v1.1-COMPLIANT GAS GAUGE FOR USE WITH THE bq29312

### FEATURES

- Provides Accurate Measurement of Available Charge in Li-Ion and Li-Polymer Batteries
- Supports the Smart Battery Specification (SBS) V1.1
- Integrated Time Base Removes Need for External Crystal with Optional Crystal input
- Works With the TI bq29312 Analog Front-End (AFE) Protection IC to Provide Complete Pack Electronics for 7.2-V, 10.8-V or 14.4-V Battery Packs With Few External Components
- Based on a Powerful Low-Power RISC CPU Core With High-Performance Peripherals
- Integrated Flash Memory Eliminates the Need for External Configuration EEPROM
- Uses 16-Bit Delta Sigma Converter for Accurate Voltage and Temperature Measurements
- Measures Charge Flow Using a High Resolution 16-Bit Integrating Converter
  - Better Than 0.65-nVh of Resolution
  - Self-Calibrating
  - Offset Error Less Than 1- $\mu$ V
- Programmable Cell Modeling for Maximum Battery Fuel Gauge Accuracy
- Drives 3-, 4-, or 5-Segment LED Display for Remaining Capacity Indication
- Available in a 38-Pin TSSOP (DBT) Package

### APPLICATIONS

- Notebook PCs
- Medical and Test Equipment
- Portable Instrumentation

### DESCRIPTION

The bq2084-V140 SBS-compliant gas gauge IC for battery pack or in-system installation maintains an accurate record of available charge in Li-ion or Li-polymer batteries. The bq2084-V140 monitors capacity and other critical parameters of the battery pack and reports the information to the system host controller over a serial communication bus. It is designed to work with the bq29312 AFE protection IC to maximize functionality and safety and minimize component count and cost in smart battery circuits. Using information from the bq2084-V140, the host controller can manage remaining battery power to extend the system run time as much as possible.

The bq2084-V140 uses an integrating converter with continuous sampling for the measurement of battery charge and discharge currents. Optimized for coulomb counting in portable applications, the self-calibrating integrating converter has a resolution better than 0.65-nVh and an offset measurement error of less than 1- $\mu$ V (typical). For voltage and temperature reporting, the bq2084-V140 uses a 16-bit A-to-D converter. With the bq29312, the onboard ADC also monitors the pack and individual cell voltages in a battery pack and allows the bq2084-V140 to generate the control signals necessary to implement the cell balancing and the required safety protection for Li-ion and Li-polymer battery chemistries.

The bq2084-V140 supports the Smart Battery Data (SBDData) commands and charge-control functions. It communicates data using the System Management Bus (SMBus) 2-wire protocol. The data available include the battery's remaining capacity, temperature, voltage, current, and remaining run-time predictions.

The bq2084-V140 provides LED drivers and a pushbutton input to depict remaining battery capacity from full to empty in 20%, 25%, or 33% increments with a 3-, 4-, or 5-segment display.



Please be aware that an important notice concerning availability, standard warranty, and use in critical applications of Texas Instruments semiconductor products and disclaimers thereto appears at the end of this data sheet.



These devices have limited built-in ESD protection. The leads should be shorted together or the device placed in conductive foam during storage or handling to prevent electrostatic damage to the MOS gates.

## DESCRIPTION (CONTINUED)

The bq2084-V140 contains 1k bytes of internal data flash memory, which store configuration information. The information includes nominal capacity and voltage, self-discharge rate, rate compensation factors, and other programmable cell-modeling factors used to accurately adjust remaining capacity for use-conditions based on time, rate, and temperature. The bq2084-V140 also automatically calibrates or learns the true battery capacity in the course of a discharge cycle from programmable near full to near empty levels.

The bq29312 analog front-end (AFE) protection IC is used to maximize functionality and safety and minimize component count and cost in smart battery circuits. The bq29312 AFE protection IC provides power to the bq2084-V140 from a 2-, 3-, or 4-series Li-ion cell stack, eliminating the need for an external regulator circuit.

## ORDERING INFORMATION

T <sub>A</sub>	PACKAGE <sup>(1)</sup>	
	38-PIN TSSOP (DBT) <sup>(2)</sup>	36-PIN QFN (RTT) <sup>(3)</sup>
–20°C to 85°C	bq2084DBT-V140	bq2084RTT-V140

- (1) For the most current package and ordering information, see the Package Option Addendum at the end of this document, or see the TI Web site at [www.ti.com](http://www.ti.com).
- (2) The bq2084DBT-V140 is available in tape and reel. Add an R suffix to the device type (e.g., bq2084DBTR-V140) to order tape and reel version.
- (3) The bq2084RTT-V140 is available in tape and reel only. Add an T suffix to the device type (e.g., bq2084RTTT-V140) to order mini tape and reel version.

## ABSOLUTE MAXIMUM RATINGS

over operating free-air temperature range unless otherwise noted<sup>(1)</sup>

	UNIT
Supply voltage range, V <sub>DD</sub> relative to V <sub>SS</sub> <sup>(2)</sup>	–0.3 V to 4.1 V
Open-drain I/O pins, V <sub>(IOD)</sub> relative to V <sub>SS</sub> <sup>(2)</sup>	–0.3 V to 6 V
Input voltage range to all other pins, V <sub>I</sub> relative to V <sub>SS</sub> <sup>(2)</sup>	–0.3 V to V <sub>DD</sub> + 0.3 V
T <sub>A</sub> Operating free-air temperature range	–20°C to 85°C
T <sub>stg</sub> Storage temperature range	–65°C to 150°C

- (1) Stresses beyond those listed under *absolute maximum ratings* may cause permanent damage to the device. These are stress ratings only, and functional operation of the device at these or any other conditions beyond those indicated under *recommended operating conditions* is not implied. Exposure to absolute-maximum-rated conditions for extended periods may affect device reliability.
- (2) V<sub>SS</sub> refers to the common node of V<sub>(SSA)</sub>, V<sub>(SSD)</sub>, and V<sub>(SSP)</sub>.

## ELECTRICAL CHARACTERISTICS

$V_{DD} = 3\text{ V to }3.6\text{ V}$ ,  $T_A = -20^\circ\text{C to }85^\circ\text{C}$  unless otherwise noted

PARAMETER		TEST CONDITIONS	MIN	TYP	MAX	UNIT
$V_{DD}$	Supply voltage	VDDA and VDDD	3	3.3	3.6	V
$I_{DD}$	Operating mode current	No flash programming or LEDs active		380		$\mu\text{A}$
$I_{(SLP)}$	Low-power storage mode current	Sleep mode		8		$\mu\text{A}$
$V_{OL}$	Output voltage low SMBC, SMBD, SDATA, SCLK, $\overline{\text{SAFE}}$ , PU	$I_{OL} = 0.5\text{ mA}$			0.4	V
	LED1-LED5	$I_{OL} = 10\text{ mA}$			0.4	
$V_{IL}$	Input voltage low SMBC, SMBD, SDATA, SCLK, EVENT, PU, PRES, PFIN		-0.3		0.8	V
	DISP		-0.3		0.8	
$V_{IH}$	Input voltage high SMBC, SMBD, SDATA, SCLK, EVENT, PU, PRES, PFIN		2		6	V
	DISP		2	$V_{DD} + 0.3$		
$V_{(A11)}$	Input voltage range VIN, TS		$V_{SS} - 0.3$		1.0	V
$V_{(A12)}$	Input voltage range SR1, SR2		$V_{SS} - 0.25$		0.25	V
$Z_{(A11)}$	Input impedance SR1, SR2	-0.25 V to 0.25 V	2.5			$\text{M}\Omega$
$Z_{(A12)}$	Input impedance VIN, TS	0 V–1 V	8			$\text{M}\Omega$
<b>POWER-ON RESET</b>						
$V_{IT+}$	Negative-going voltage input		2.1	2.3	2.5	V
$V_{hys}$	Power-on reset hysteresis		50	125	200	mV

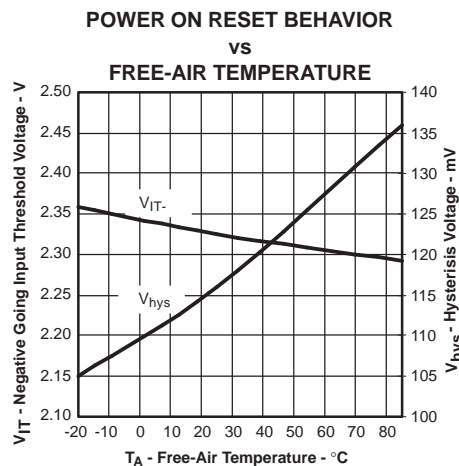

## INTEGRATING ADC CHARACTERISTICS

$V_{DD} = 3\text{ V to }3.6\text{ V}$ ,  $T_A = -20^\circ\text{C to }85^\circ\text{C}$  unless otherwise noted

PARAMETER		TEST CONDITIONS	MIN	TYP	MAX	UNIT
$V_{(SR)}$	Input voltage range, $V_{(SR2)}$ and $V_{(SR1)}$	$V_{SR} = V_{(SR2)} - V_{(SR1)}$	-0.25		0.25	V
$V_{(SROS)}$	Input offset			1		mV
INL	Integral nonlinearity error	FAST = 0, -0.1 V to $0.8 \times V_{ref}$		0.004%	0.018%	

## PLL SWITCHING CHARACTERISTICS

$V_{DD} = 3\text{ V to }3.6\text{ V}$ ,  $T_A = -20^\circ\text{C to }85^\circ\text{C}$  unless otherwise noted

PARAMETER		TEST CONDITIONS	MIN	TYP	MAX	UNIT
$t_{(SP)}$	Start-up time <sup>(1)</sup>	$\pm 0.5\%$ frequency error		2	5	ms

(1) The frequency error is measured from the trimmed frequency of the internal system clock, which is 128 x oscillator frequency, nominally 4.194 MHz.

## OSCILLATOR

$V_{DD} = 3\text{ V to }3.6\text{ V}$ ,  $T_A = -20^\circ\text{C to }85^\circ\text{C}$  (unless otherwise noted) (TYP:  $V_{DD} = 3.3\text{ V}$ ,  $T_A = 25^\circ\text{C}$ )

PARAMETER		TEST CONDITIONS	MIN	TYP	MAX	UNIT
$f_{(eio)}$	Frequency error from 32.768 kHz	ROSC = 100k	-2%	0.5%	2%	
		XCK1 = 12 pF XTAL	-0.25%		0.25%	
$f_{(dio)}$	Frequency drift <sup>(1)</sup>	ROSC = 100k, $T_A = 0^\circ\text{C to }50^\circ\text{C}$	-1%		1%	
$f_{(sio)}$	Start-up time <sup>(2)</sup>	ROSC = 100k			200	$\mu\text{s}$
$f_{(sxo)}$		XCK1 = 12 pF XTAL			250	ms

(1) The frequency drift is measured from the trimmed frequency at  $V_{DD} = 3.3\text{ V}$ ,  $T_A = 25^\circ\text{C}$ .

(2) The start-up time is defined as the time it takes for the oscillator output frequency to be  $\pm 1\%$

## DATA FLASH MEMORY CHARACTERISTICS

$V_{DD} = 3\text{ V to }3.6\text{ V}$ ,  $T_A = -20^\circ\text{C to }85^\circ\text{C}$  unless otherwise noted

PARAMETER		TEST CONDITIONS	MIN	TYP	MAX	UNIT
$t_{DR}$	Data retention	See <sup>(1)</sup>	10			Years
	Flash programming write-cycles	See <sup>(1)</sup>	20k			Cycles
$t_{(WORDPROG)}$	Word programming time	See <sup>(1)</sup>			2	ms
$I_{(DDPROG)}$	Flash-write supply current	See <sup>(1)</sup>		8	12	mA

(1) Specified by design. Not production tested.

## REGISTER BACKUP

PARAMETER		TEST CONDITIONS	MIN	TYP	MAX	UNIT
$I_{(RBI)}$	RBI data-retention input current	$V_{RBI} > 2\text{ V}$ , $V_{DD} < V_{IT}$		10	100	nA
$V_{(RBI)}$	RBI data-retention voltage <sup>(1)</sup>		1.3			V

(1) Specified by design. Not production tested.

## SMBus TIMING SPECIFICATIONS

$V_{DD} = 3\text{ V to }3.6\text{ V}$ ,  $T_A = -20^\circ\text{C to }85^\circ\text{C}$  unless otherwise noted

PARAMETER		TEST CONDITIONS	MIN	TYP	MAX	UNIT
$f_{(SMB)}$	SMBus operating frequency	Slave mode, SMBC 50% duty cycle	10		100	kHz
$f_{(MAS)}$	SMBus master clock frequency	Master mode, no clock low slave extend		51.2		kHz
$t_{(BUF)}$	Bus free time between start and stop		4.7			$\mu\text{s}$
$T_{(HD:STA)}$	Hold time after (repeated) start		4			$\mu\text{s}$
$t_{(SU:STA)}$	Repeated start setup time		4.7			$\mu\text{s}$
$t_{(SU:STO)}$	Stop setup time		4			$\mu\text{s}$
$t_{(HD:DAT)}$	Data hold time	Receive mode	0			ns
		Transmit mode	300			
$t_{(SU:DAT)}$	Data setup time		250			ns
$t_{(TIMEOUT)}$	Error signal/detect	See <sup>(1)</sup>	25		35	ms
$t_{(LOW)}$	Clock low period		4.7			$\mu\text{s}$
$t_{(HIGH)}$	Clock high period	See <sup>(2)</sup>	4		50	$\mu\text{s}$
$t_{(LOW:SEXT)}$	Cumulative clock low slave extend time	See <sup>(3)</sup>			25	ms
$t_{(LOW:MEXT)}$	Cumulative clock low master extend time	See <sup>(4)</sup>			10	ms
$t_f$	Clock/data fall time	$(V_{ILMAX} - 0.15\text{ V})$ to $(V_{IHMIN} + 0.15\text{ V})$			300	ns
$t_r$	Clock/data rise time	$0.9 V_{DD}$ to $(V_{ILMAX} - 0.15\text{ V})$			1000	ns

(1) The bq2084-V140 times out when any clock low exceeds  $t_{(TIMEOUT)}$ .

(2)  $t_{(HIGH)}$  Max. is minimum bus idle time. SMBC = 1 for  $t > 50\text{ ms}$  causes reset of any transaction involving bq2084-V140 that is in progress.

(3)  $t_{(LOW:SEXT)}$  is the cumulative time a slave device is allowed to extend the clock cycles in one message from initial start to the stop.

(4)  $t_{(LOW:MEXT)}$  is the cumulative time a master device is allowed to extend the clock cycles in one message from initial start to the stop.

## SMBus TIMING DIAGRAMS

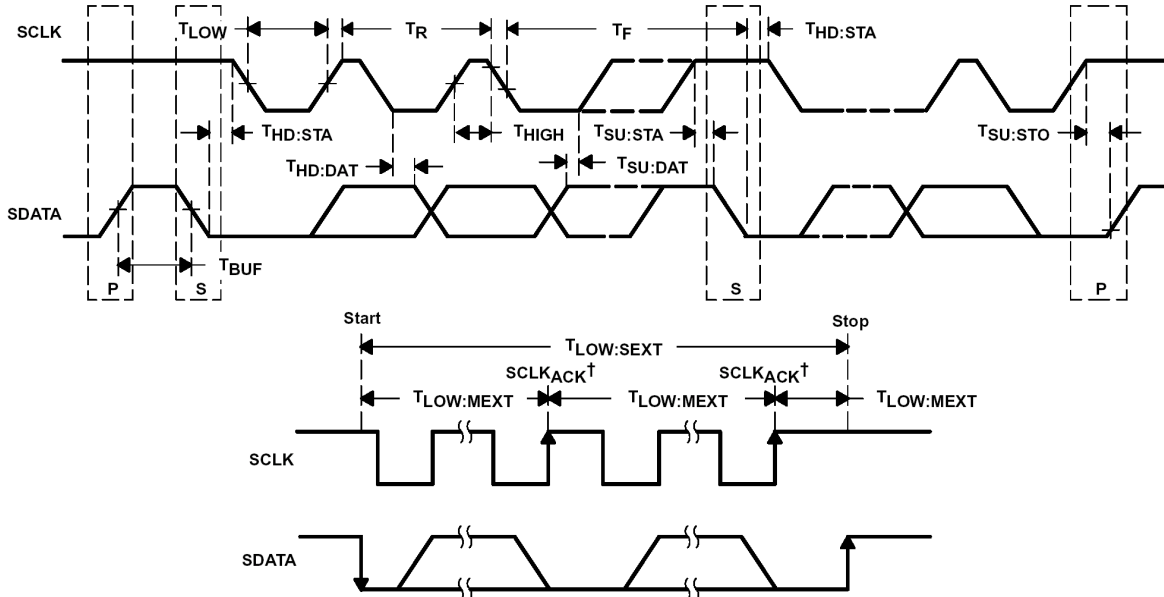

$^\dagger SCLKACK$  is the acknowledge-related clock pulse generated by the master.

## SYSTEM DIAGRAM

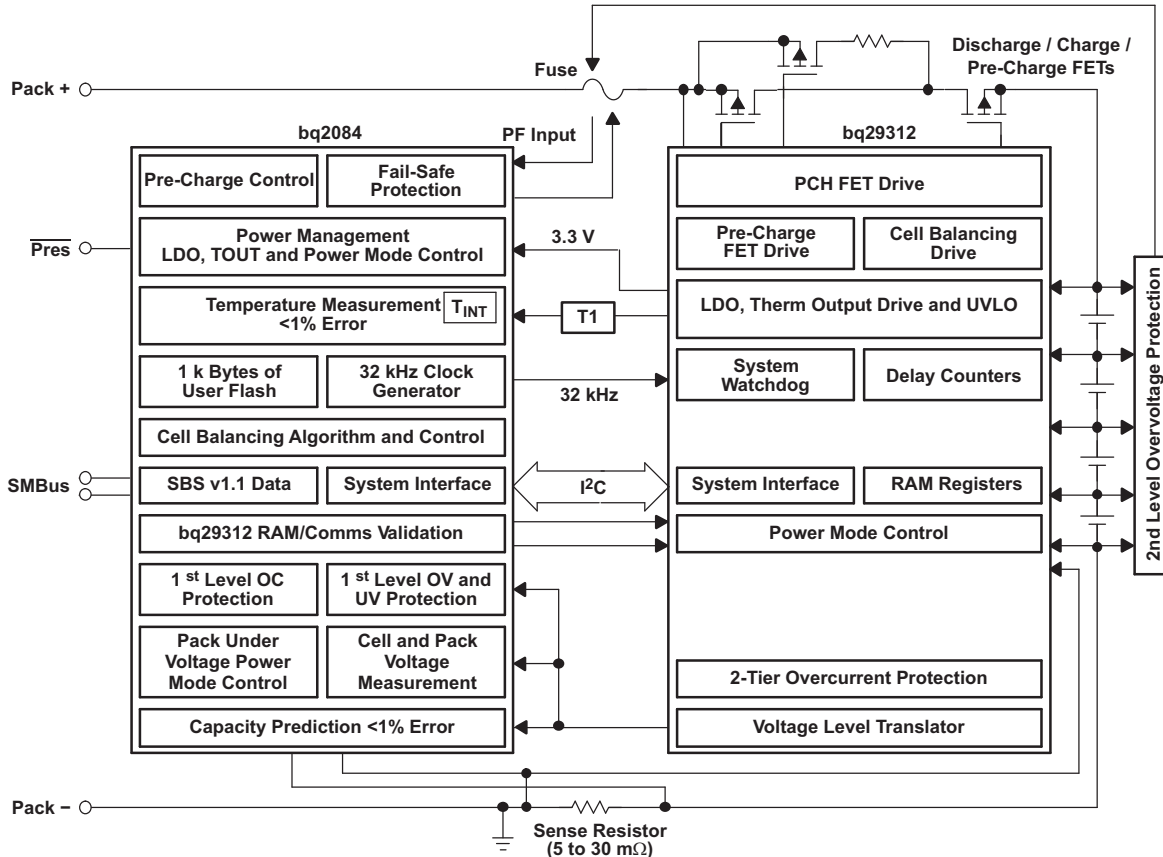

**PIN ASSIGNMENTS**

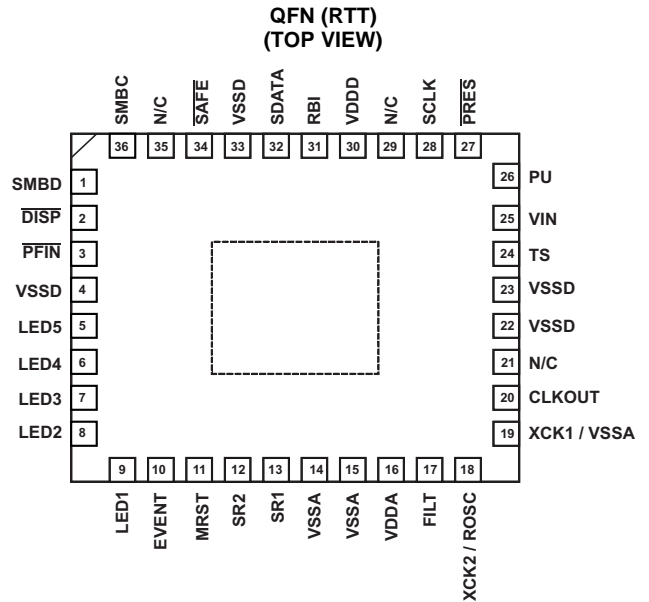
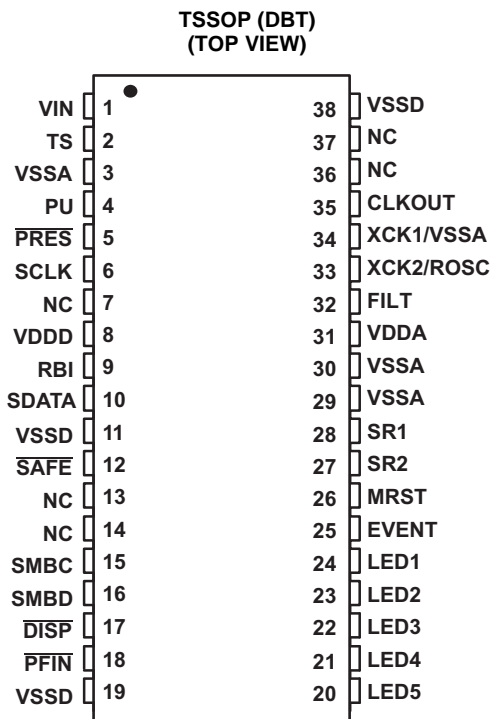

**Terminal Functions**

NAME	TERMINAL		I/O	DESCRIPTION
	NO. TSSOP	NO. QFN		
DISP	17	2	I	Display control for the LED drivers LED1 through LED5
CLKOUT	35	20	O	32.768-kHz output to the bq29312
FILT	32	17	I	Analog input connected to the external PLL filter
EVENT	25	10	I	Input from bq29312 XALERT output
LED1	24	9	O	LED display segments that each may drive an external LED
LED2	23	8	O	
LED3	22	7	O	
LED4	21	6	O	
LED5	20	5	O	
MRST	26	11	I	Master reset input that forces the device into reset when held high
NC	7, 13, 14, 36, 37	21, 29, 35	–	No connection
PFIN	18	3	I	Active low input to detect secondary protector output status
PRES	5	27	I	Active low input to sense system insertion
PU	4	26	O	Output to pull up the PRES pin for detection
RBI	9	31	I	Register backup that provides backup potential to the bq2084-V140 data registers during periods of low operating voltage. RBI accepts a storage capacitor or a battery input.
SAFE	12	34	O	Active low output for additional level of safety protection; e.g., fuse blow.
SCLK	6	28	O	Communication clock to the bq29312
SDATA	10	32	I/O	Data transfer to and from bq29312
SMBC	15	36	I/O	SMBus clock open-drain bidirectional pin used to clock the data transfer to and from the bq2084-V140

**Terminal Functions (continued)**

TERMINAL			I/O	DESCRIPTION
NAME	NO. TSSOP	NO. QFN		
SMBD	16	1	I/O	SMBus data open-drain bidirectional pin used to transfer address and data to and from the bq2084-V140
SR1	28	13	I	Connections for a small-value sense resistor to monitor the battery charge- and discharge-current flow
SR2	27	12	I	
TS	2	24	I	Thermistor voltage input connection to monitor temperature
VDDA	31	16	I	Positive supply for analog circuitry
VDDD	8	30	I	Positive supply for digital circuitry and I/O pins
VIN	1	25	I	Single-cell voltage input from the bq29312
VSSA	3, 29, 30	14, 15	I	Negative supply for analog circuitry
VSSD	11, 19, 38	4, 22, 23, 33	I	Negative supply for digital circuitry
XCK1/VSSA	34	19	I	32.768-kHz crystal oscillator input pin or connected to VSSA if the internal oscillator is used
XCK2/ROSC	33	18	O	32.768-kHz crystal oscillator output pin or connected to a 100-k $\Omega$ , 50 ppm or better resistor if the internal oscillator is used

**FUNCTIONAL DESCRIPTION**

**OSCILLATOR FUNCTION**

The oscillator of the bq2084-V140 can be set up for an internal or external operation. As the bq2084-V140 powers up it automatically attempts to start the internal oscillator, but if a 100-k $\Omega$  resistor is not connected to ROSC (pin 33), then it attempts to start the oscillator using an external 32.768-kHz crystal. Either the 100-k $\Omega$  ROSC resistor OR the 12 pF 32.768-kHz crystal should be mounted, NOT both.

The performance of the internal oscillator depends on the tolerance of the 100-k $\Omega$  resistor connected between ROSC (pin 33) and VSSA (pin 34). It is recommended that this resistor be as close to the bq2084-V140 as possible and that it has a specification of  $\pm 0.1\%$  tolerance and  $\pm 50$  ppm temperature drift or better. The 12-pF crystal, if used, should also be placed as close to the XCK1 (pin 34) and XCK2 (pin 33) pins as possible. The layout of the PCB around these pins and components is also an additional contributing factor to oscillator performance degradation.

The average temperature drift error of the oscillator function over a learning charge or discharge cycle introduces an equal capacity prediction error in a learned full charge capacity (FCC).

**SYSTEM PRESENT OPERATION**

When the bq2084-V140 detects that the battery is inserted into the system via a low state on the  $\overline{\text{PRES}}$  input, the bq2084-V140 enters normal operating mode and sets the PRES bit in *PackStatus()*. The discharge FET turns on within 250 ms of pack insertion. When the pack is removed from the system and the PRES input is high, then the bq2084-V140 enters the battery removed state and turns OFF the charge and discharge FETs, and enables the 0-V/precharging FET. If NR in Misc Config is set, then the PRES input can be left floating as it is not used.

**GENERAL OPERATION**

The bq2084-V140 determines battery capacity by monitoring the amount of charge input or removed from a rechargeable battery. In addition to measuring charge and discharge, the bq2084-V140 measures individual cell voltages, pack voltage, temperature, and current, estimates battery self-discharge, and monitors the battery for low-voltage thresholds using features of the bq29312 AFE device.

The bq2084-V140 measures charge and discharge activity by monitoring the voltage across a small-value series sense resistor between the cell stack negative terminal and the negative terminal of the battery pack. The available battery charge is determined by monitoring this voltage and correcting the measurement for environmental and operating conditions.

## FUNCTIONAL DESCRIPTION (continued)

The bq2084-V140 interfaces with the bq29312 to perform battery protection, cell balancing, and voltage translation functions. The bq2084-V140 can accept any NTC thermistor (default is Semitec 103AT) for temperature measurement or can also be configured to use its internal temperature sensor. The bq2084-V140 uses temperature to monitor the battery pack and to compensate the self-discharge estimate.

## MEASUREMENTS

The bq2084-V140 uses an integrating sigma-delta analog-to-digital converter (ADC) for current measurement and a second sigma-delta ADC for individual cell and battery voltage and temperature measurement. The individual cell and pack voltages, *Voltage()*, *Current()*, *AverageCurrent()* and *Temperature()* are updated every 1 s during normal operation.

## CHARGE AND DISCHARGE COUNTING

The integrating ADC measures the charge and discharge flow of the battery by monitoring a small-value sense resistor between the SR1 and SR2 pins. The integrating ADC measures bipolar signals from -0.25 V to 0.25 $\mu$ V. The bq2084-V140 detects charge activity when  $VSR = V(SR1) - V(SR2)$  is positive and discharge activity when  $VSR = V(SR1) - V(SR2)$  is negative. The bq2084-V140 continuously integrates the signal over time, using an internal counter. The fundamental rate of the counter is 0.65 nVh. The bq2084-V140 updates *RemainingCapacity()* with the charge or discharge accumulated in this internal counter once every second.

## OFFSET CALIBRATION

The bq2084-V140 provides an auto-calibration feature to cancel the voltage offset error across SR1 and SR2 for maximum charge measurement accuracy. The bq2084-V140 performs auto-calibration when the SMBus lines stay low for a minimum of 20 s when it internally connects SR1 to SR2 and measures the internal offset. With this feature the bq2084-V140 is capable of automatic offset calibration down to <1  $\mu$ V.

## DIGITAL FILTER

The bq2084-V140 does not measure charge or discharge counts below the digital filter threshold. The digital filter threshold is programmed in the *Digital Filter* DF 0x2c and should be set sufficiently high to prevent false signal detection with no charge or discharge flowing through the sense resistor.

## VOLTAGE

While monitoring SR1 and SR2 for charge and discharge currents, the bq2084-V140 monitors the individual series cell voltages through the bq29312. The bq2084-V140 configures the bq29312 to present the selected cell to the CELL pin of the bq29312, which should be connected to VIN of the bq2084-V140. The internal ADC of the bq2084-V140 then measures the voltage and scales it appropriately. The bq2084-V140 then reports the *Voltage()* and the individual cell voltages in *VCELL1()*, *VCELL2()*, *VCELL3()*, and *VCELL4()*. An additional SMBus command (0x45) returns the measured ADC Reading of the PACK input to the AFE.

## CURRENT

The bq2084-V140 uses the SR1 and SR2 inputs to measure and calculate the battery charge and discharge current. This value is reported via the SBS command *Current()*. *AverageCurrent()* is implemented as a single-pole IIR filter with a 14.5-s time constant.

## TEMPERATURE

The TS input of the bq2084-V140 along with an NTC thermistor measures the battery temperature as shown in the schematic. The bq2084-V140 reports temperature via the SBS command *Temperature()*.

The bq2084-V140 can also be configured to use its internal temperature sensor by setting the IT bit in *Misc Configuration* DF 0x2a-0x2b. Data flash locations DF 0xb5 through DF 0xc0 also have to be changed to prescribed values if the internal temperature sensor option is selected.



FUNCTIONAL DESCRIPTION (continued)

Table 1. Data Flash Settings for Internal or External Temperature Sensor

LABEL	LOCATION	INTERNAL TEMP SENSOR SETTING	EXTERNAL TEMP SENSOR SETTING (Semitec 103AT)
	Dec (Hex)	Dec (Hex)	Dec (Hex)
Misc. Config	42 (0x2a)	Bit 7 = 1	Bit 7 = 0
TS Const1 A3	164/5 (0xb5/6)	0 (0x0000)	-28285 (0x9183)
TS Const2 A2	166/7 (0xb7/8)	0 (0x0000)	20848 (0x5170)
TS Const3 A1	168/9 (0xb9/a)	-11136 (0xd480)	-7537 (0xe28f)
TS Const4 A0	170/1 (0xbb/c)	5734 (0x1666)	4012 (0x0fac)
Min Temp AD	172/3 (0xbd/e)	0 (0x0000)	0 (0x000)
Max Temp	174/5 (0xbf/c0)	5734 (0x1666)	4012 (0x0fac)

GAS GAUGE OPERATION

General

The operational overview in Figure 1 illustrates the gas gauge operation of the bq2084-V140. Table 3 describes the bq2084-V140 registers.

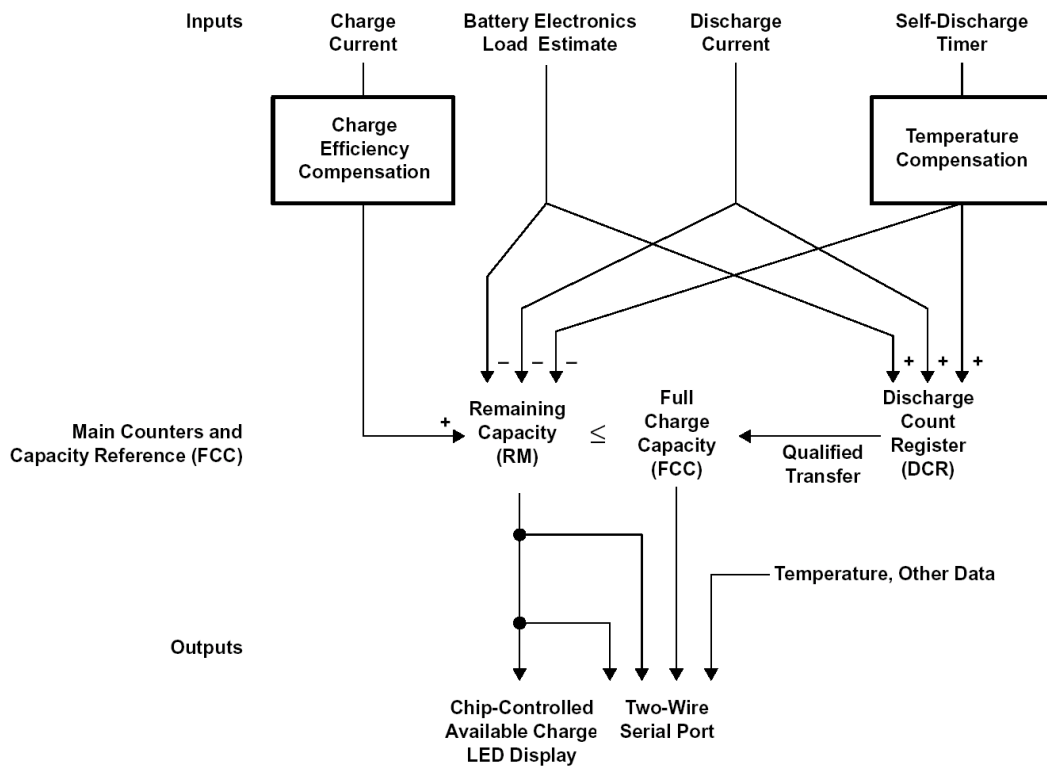

Figure 1. bq2084-V140 Gas Gauging Operational Overview

The bq2084-V140 accumulates a measure of charge and discharge currents and estimates self-discharge of the battery. The bq2084-V140 compensates the charge current measurement for temperature and state-of-charge of the battery. The bq2084-V140 also adjusts the self-discharge estimation based on temperature.

The main charge counter *RemainingCapacity()* (RM) represents the available capacity or energy in the battery at any given time. The bq2084-V140 adjusts RM for charge, self-discharge, and other compensation factors. The information in the RM register is accessible through the SMBus interface and is also represented through the LED display.

The *FullChargeCapacity()* (FCC) register represents the last measured learned full discharge of the battery. It is used as the battery full-charge reference for relative capacity indication. The bq2084-V140 updates FCC after the battery undergoes a qualified discharge from nearly full to a low battery level. FCC is accessible through the SMBus interface.

The Discharge Count Register (DCR) is a non-accessible register that tracks discharge of the battery. The bq2084-V140 uses the DCR register to update the FCC register if the battery undergoes a qualified discharge from nearly full to a low battery level. In this way, the bq2084-V140 learns the true discharge capacity of the battery under system-use conditions.

## Main Gas-Gauge Registers

### **RemainingCapacity() (RM)**

RM represents the remaining capacity in the battery. The bq2084-V140 computes RM in units of either mAh or 10 mWh depending on the selected mode. See *Battery Mode()* (0x03) for units configuration. RM counts up during charge to a maximum value of *FullChargeCapacity()* (FCC) and down during discharge and self-discharge to a minimum of 0. In addition to charge and self-discharge compensation, the bq2084-V140 calibrates RM at three low-battery-voltage thresholds, EDV2, EDV1, and EDV0 and three programmable midrange thresholds VOC25, VOC50, and VOC75. This provides a voltage-based calibration to the RM counter.

### **DesignCapacity () (DC)**

DC is the user-specified battery full capacity. It is calculated from *Pack Capacity* DF 0x32-0x33 and is represented in units of mAh or 10 mWh. It also represents the full-battery reference for the absolute display mode.

### **FullChargeCapacity() (FCC)**

FCC is the last learned measured discharge capacity of the battery. It is represented in units of either mAh or 10 mWh, depending on the selected mode. On initialization, the bq2084-V140 sets FCC to the value stored in *Full Charge Capacity* DF 0x36-0x37. During subsequent discharges, the bq2084-V140 updates FCC with the last learned measured discharge capacity of the battery. The last learned measured discharge of the battery is based on the value in the Discharge Count Register (DCR) after a qualified discharge occurs. Once updated, the bq2084-V140 writes the new FCC value to data flash in mAh to *Full Charge Capacity*. FCC represents the full-battery reference for the relative display mode, relative state of charge and *AtRate()* calculations.

### **Discharge Count Register (DCR)**

The DCR register counts up during discharge, independent of RM. DCR counts discharge activity, battery load estimation, and self-discharge increments. The bq2084-V140 initializes DCR, at the beginning of a discharge, to FCC - RM when FCC - RM is within the programmed value in *Near Full* DF 0x30. The DCR initial value of FCC - RM is reduced by FCC/128 if SC = 1 (bit 5 in *Gauge Configuration*) and is not reduced if SC = 0. DCR stops counting when the battery voltage reaches the EDV2 threshold on discharge.

## Capacity Learning (FCC Update) and Qualified Discharge

The bq2084-V140 updates FCC with an amount based on the value in DCR if a qualified discharge occurs. The new value for FCC equals the DCR value plus the programmable nearly full and low battery levels, according to the following equation:

$$\text{FCC (new)} = \text{DCR (final)} = \text{DCR (initial)} + \text{Measured Discharge to EDV2} + (\text{FCC} \times \text{Battery Low\%})$$

here *Battery Low %* = (value stored in DF 0x2f) ÷ 2.56

A qualified discharge occurs if the battery discharges from RM = FCC - *Near Full* to the EDV2 voltage threshold with the following conditions:

- No more than 256 mAh of self-discharge or battery load estimation occurs during the discharge period.
- The temperature does not drop below the low temperature threshold programmed in *Learning Low Temp* DF 0xac during the discharge period.
- The battery voltage reaches the EDV2 threshold during the discharge period, and the voltage is greater than or equal to the EDV2 threshold minus 256 mV when the bq2084-V140 detects EDV2.
- No midrange voltage correction occurs during the discharge period.

- Current remains  $\leq 3C/32$  when EDV2 or *Battery Low %* level is reached.
- No overload condition exists when EDV2 threshold is reached, or if  $RM()$  has dropped to *Battery Low %* x FCC,
- No valid charge activity occurs during the discharge period. A valid charge is defined as an uninterrupted charge of 10 mAh into the battery.

The bq2084-V140 sets  $VDQ = 1$  in  $PackStatus()$  when qualified discharge begins. The bq2084-V140 sets  $VDQ = 0$  if any disqualifying condition occurs. FCC cannot be reduced by more than 256 mAh or increased by more than 512 mAh during any single update cycle. The bq2084-V140 saves the new FCC value to the data flash within 4 seconds of being updated.

### End-of-Discharge Thresholds and Capacity Correction

The bq2084-V140 monitors the battery for three low-voltage thresholds, EDV0, EDV1, and EDV2. The EDV thresholds can be programmed for determination based on the overall pack voltage or an individual cell level. The EDVV bit in *Pack Configuration* DF 0x28 configures the bq2084-V140 for overall voltage or single-cell EDV thresholds. If programmed for single-cell EDV determination, the bq2084-V140 determines EDV on the basis of the lowest single-cell voltage. Fixed EDV thresholds must be programmed in *EMF/EDV0* DF 0x95-0x96, *EDV C0 Factor/EDV1* DF 0x97-0x98, and *EDV R Factor/EDV2* DF 0x99-0x9a.

If the CEDV bit in *Gauge Configuration* DF 0x29 is set, automatic compensated EDVs are enabled and the bq2084-V140 computes the EDV0, EDV1, and EDV2 voltage thresholds based on the values in DF 0x95-0xa0 and the battery's current discharge rate and temperature. If FEDV0 in *Gauge Configuration* is also set then EDV0 is not compensated. The bq2084-V140 disables EDV detection if  $Current()$  exceeds the *Overload Current* threshold programmed in DF 0x5b-DF 0x5c. The bq2084-V140 resumes EDV threshold detection after  $Current()$  drops below the *Overload Current* threshold. Any EDV threshold detected is reset after charge is detected and  $VDQ$  is cleared after 10 mAh of charge.

The bq2084-V140 uses the EDV thresholds to apply voltage-based corrections to the RM register according to [Table 2](#).

**Table 2. State-of-Charge Based on Low Battery Voltage**

THRESHOLD	RELATIVE STATE OF CHARGE
EDV0	0%
EDV1	3%
EDV2	Battery Low %

The bq2084-V140 performs EDV-based RM adjustments with  $Current() \leq C/32$ . No EDV flags are set if current  $< C/32$ .

The bq2084-V140 adjusts RM as it detects each threshold. If the voltage threshold is reached before the corresponding capacity on discharge, the bq2084-V140 reduces RM to the appropriate amount as shown in [Table 2](#).

If an RM % level is reached on discharge before the voltage reaches the corresponding threshold, then RM is held at that % level until the threshold is reached. RM is only held if  $VDQ = 1$ , indicating a valid learning cycle is in progress. If *Battery Low %* is set to zero, EDV1 and EDV0 corrections are disabled.

### EDV Thresholds and Near-Full Programming

The bq2084-V140 uses the values stored in data flash for the EDV0, EDV1, and EDV2 values or calculates the three thresholds from a base value and the temperature, capacity, and rate adjustment factors stored in data flash. If EDV compensation is disabled, then EDV0, EDV1, and EDV2 are stored directly in mV in DF 0x95-0x96, DF 0x97-0x98, and DF 0x99-0x9a, respectively.

For capacity correction at EDV2, *Battery Low %* DF 0x2f can be set at a desired state-of-charge, *STATEOFCHARGE%*, in the range of 3-19%. Typical values for *STATEOFCHARGE%* are 5-7%, representing 5-7% capacity.

$$Battery\ Low\ \% = (STATEOFCHARGE\% \times 2.56)$$

The bq2084-V140 updates FCC if a qualified discharge occurs from a near-full threshold of FCC - *Near Full*, until EDV2 condition is reached. The desired near-full threshold window is programmed in *Near Full* in DF 0x30, 0x31 in mAh.

### EDV Discharge Rate and Temperature Compensation Programming

If EDV compensation is enabled, the bq2084-V140 calculates battery voltage to determine EDV0, EDV1, and EDV2 thresholds as a function of battery capacity, temperature, and discharge load. The general equation for EDV0, EDV1, and EDV2 calculation is

$$EDV_{0,1,2} = n (EMF \times FBL - |ILOAD| \times R0 \times FTZ)$$

EMF is a no-load cell voltage higher than the highest cell EDV threshold computed. EMF is programmed in mV in *EMF/EDV1* DF 0x95-0x96.

ILOAD is the current discharge load magnitude.

n = the number of series cells

FBL is the factor that adjusts the EDV voltage for battery capacity and temperature to match the no-load characteristics of the battery.

$$FBL = f (C0, C + C1, T)$$

C (either 0%, 3%, or *Battery Low %* for EDV0, EDV1, and EDV2, respectively) and C0 are the capacity-related EDV adjustment factors. C0 is programmed in *EDV C0 Factor/EDV1* DF 0x97-98. C1 is the desired residual battery capacity remaining at EDV0 (RM = 0). The C1 factor is stored in *EDV C1 Factor* DF 0xa0.

T is the current temperature in °K.

$R0 \times FTZ$  represents the resistance of a cell as a function of temperature and capacity.

$$FTZ = f (R1, T0, T, C + C1, TC)$$

R0 is the first order rate dependency factor stored in *EDV R0 Factor/EDV2* DF 0x99-0x9a.

T is the current temperature; C is the battery capacity relating to EDV0, EDV1, and EDV2.

R1 adjusts the variation of impedance with battery capacity. R1 is programmed in *EDV R1 Rate Factor* DF 0x9d-0x9e.

T0 adjusts the variation of impedance with battery temperature. T0 is programmed in *EDV T0 Rate Factor* DF 0x9b-0x9c.

TC adjusts the variation of impedance for cold temperatures ( $T < 23^{\circ}\text{C}$ ). TC is programmed in *EDV TC* DF 0x9f.

Typical values for the EDV compensation factors, based on overall pack voltages for a Li-ion 3s2p 18650 pack, are:

$$EMF = 11550/3$$

$$T0 = 4475$$

$$C0 = 235$$

$$C1 = 0$$

$$R0 = 5350/3$$

$$R1 = 250$$

$$TC = 3$$

**Table 3. bq2084-V140 Register Functions**

FUNCTION	COMMAND CODE	ACCESS	UNITS
ManufacturerAccess	0x00	Read/write	NA
RemainingCapacityAlarm	0x01	Read/write	mAh, 10 mWh
RemainingTimeAlarm	0x02	Read/write	minutes
BatteryMode	0x03	Read/write	NA
AtRate	0x04	Read/write	mA, 10 mW
AtRateTimeToFull	0x05	Read	minutes
AtRateTimeToEmpty	0x06	Read	minutes
AtRateOK	0x07	Read	Boolean
Temperature	0x08	Read	0.1°K
Voltage	0x09	Read	mV
Current	0x0a	Read	mA
AverageCurrent	0x0b	Read	mA
MaxError	0x0c	Read	percent
RelativeStateOfCharge	0x0d	Read	percent
AbsoluteStateOfCharge	0x0e	Read	percent
RemainingCapacity	0x0f	Read	mAh, 10 mWh
FullChargeCapacity	0x10	Read	mAh, 10 mWh
RunTimeToEmpty	0x11	Read	minutes
AverageTimeToEmpty	0x12	Read	minutes
AverageTimeToFull	0x13	Read	minutes
ChargingCurrent	0x14	Read	mA
ChargingVoltage	0x15	Read	mV
Battery Status	0x16	Read	NA
CycleCount	0x17	Read	cycles
DesignCapacity	0x18	Read	mAh, 10 mWh
DesignVoltage	0x19	Read	mV
SpecificationInfo	0x1a	Read	NA
ManufactureDate	0x1b	Read	NA
SerialNumber	0x1c	Read	integer
Reserved	0x1d-0x1f	0	0
ManufacturerName	0x20	Read	string
DeviceName	0x21	Read	string
DeviceChemistry	0x22	Read	string
ManufacturerData	0x23	Read	string
Pack status	0x2f (LSB)	Read	NA
Pack configuration	0x2f (MSB)	Read	NA
VCELL4	0x3c	Read	mV
VCELL3	0x3d	Read	mV
VCELL2	0x3e	Read	mV
VCELL1	0x3f	Read	mV
VPACK	0x45	Read	mV
AFEData	0x46	Read	hex

## Self-Discharge

The bq2084-V140 estimates the self-discharge of the battery to maintain an accurate measure of the battery capacity during periods of inactivity. The bq2084-V140 makes self-discharge adjustments to RM every 1/4 s when awake and periodically (determined by *Sleep Timer* DF 0xfe) when in sleep mode. The self-discharge estimation rate for 25°C is doubled for each 10 degrees above 25°C or halved for each 10 degrees below 25°C. [Table 4](#) shows the relation of the self-discharge estimation at a given temperature to the rate programmed for 25°C (Y% per day programmed in DF 0x2d).

**Table 4. Self-Discharge for Rate Programmed**

TEMPERATURE (°C)	SELF-DISCHARGE RATE
Temp < 10	1/4 Y% per day
10 ≤ Temp <20	½ Y% per day
20 ≤ Temp <30	Y% per day
30 ≤ Temp <40	2Y% per day
40 ≤ Temp <50	4Y% per day
50 ≤ Temp <60	8Y% per day
60 ≤ Temp <70	16Y% per day
70 ≤ Temp	32Y% per day

The nominal self-discharge rate, %PERDAY (% per day), is programmed in an 8-bit value *Self-Discharge Rate* DF 0x2d by the following relation:

$$\text{Self-Discharge Rate} = \%PERDAY / 0.01$$

## Battery Electronic Load Compensation

The bq2084-V140 can be configured to compensate for a constant load (as from battery electronics) present in the battery pack at all times. The bq2084-V140 applies the compensation continuously when the charge or discharge is below the digital filter. The bq2084-V140 applies the compensation (BEL) in addition to self-discharge. The compensation occurs at a rate determined by the value stored in *Electronics Load* DF 0x2e. The compensation range is 0 μA-765 μA in steps of approximately 3 μA. The data is stored as follows:

$$\text{Electronics Load} = BEL / 3$$

## Midrange Capacity Corrections

The bq2084-V140 applies midrange capacity corrections when the VCOR bit is set in *Gauge Configuration* DF 0x29. The bq2084-V140 adjusts RM to the associated percentage at three different voltage levels: VOC25, VOC50, and VOC75. The VOC values represent the open-circuit battery voltage at which RM corresponds to the associated percentage for each threshold.

For the midrange corrections to occur, the temperature must be in the range of 19°C to 31°C inclusive and Current() and AverageCurrent() must both report between -64 mA and 0. The bq2084-V140 makes midrange corrections as shown in [Table 5](#). For a correction to occur, the bq2084-V140 must detect the need for correction twice during subsequent 20-s intervals. With the VCOR bit set, the bq2084-V140 makes midrange corrections whenever conditions permit.

If the OTVC bit in *Gauge Configuration* DF 0x29 is set and VCOR = 0, the bq2084-V140 makes two Voltage() measurements, determines the average of the two readings and sets the appropriate RM level. No further RSOC% vs Voltage() validation is performed until after the next device reset.

**Table 5. Midrange Corrections**

	CONDITION	RESULT
Voltage()	$\leq \text{VOC75}$ and $\text{RelativeStateOfCharge}() \leq 63\%$	$\text{RelativeStateOfCharge}() \rightarrow 75\%$
	$\leq \text{VOC75}$ and $\text{RelativeStateOfCharge}() \leq 87\%$	$\text{RelativeStateOfCharge}() \rightarrow 75\%$
	$\leq \text{VOC50}$ and $\text{RelativeStateOfCharge}() < 38\%$	$\text{RelativeStateOfCharge}() \rightarrow 50\%$
	$< \text{VOC50}$ and $\text{RelativeStateOfCharge}() \leq 62\%$	$\text{RelativeStateOfCharge}() \rightarrow 50\%$
	$\leq \text{VOC25}$ and $\text{RelativeStateOfCharge}() \leq 13\%$	$\text{RelativeStateOfCharge}() \rightarrow 25\%$
	$< \text{VOC25}$ and $\text{RelativeStateOfCharge}() \leq 37\%$	$\text{RelativeStateOfCharge}() \rightarrow 25\%$

Three voltage-based thresholds, *VOC25 DF 0x88-0x89*, *VOC50 DF 0x83-0x84*, and *VOC75 DF 0x7e-0x7f*, are stored in the data flash in mV.

### Charge Control

The bq2084-V140 internal charge control is compatible with the constant current/constant voltage profile for Li-ion. The bq2084-V140 detects primary charge termination on the basis of the tapering charge current during the constant-voltage phase.

### Charging Voltage Broadcasts

The bq2084-V140 supports SBS charge control by broadcasting the *ChargingCurrent()* and *ChargingVoltage()* to the Smart Charger address. The bq2084-V140 broadcasts the requests every 10 seconds. The bq2084-V140 updates the values used in the charging current and voltage broadcasts based on the battery's state of charge, voltage, and temperature.

The 16-bit value (mV) for charging voltage is programmed in *Charging Voltage DF 0x03a-0x3b* although it can be set to 0 in different operating conditions. It also sets the base value for determining overvoltage conditions during charging and voltage compliance during a constant-voltage charging methodology.

The 16-bit value, *Over Voltage Margin DF 0x5d-0x5e*, sets the limit over *ChargingVoltage()* in mV that is to be considered as an overvoltage charge-suspension condition.

### Charging Current Broadcasts

*ChargingCurrent()* values are either broadcast to a Level 2 smart battery charger or read from the bq2084-V140 by a Level 3 smart battery charger. The *ChargingCurrent()* may take any of four different values: *Fast-Charging Current DF (0x3e-0x3f)*, *Maintenance Charging Current (DF 0x40-0x41)*, *Precharge Current (0x42-0x43)* or 0 depending on charge state and operating conditions.

When fast charge is allowed, the bq2084-V140 sets *ChargingCurrent()* to the rate programmed in *Fast-Charging Current DF 0x3e-0x3f*. *Fast-Charging Current* is stored in mA.

When fast charge terminates, the bq2084-V140 sets *ChargingCurrent()* to zero and then to the *MaintenanceCharging Current DF 40 0x41* when the termination condition ceases. The desired maintenance current is stored in mA.

When *Voltage()* is less than EDV0, the bq2084-V140 sets *ChargingCurrent()* to *Precharge Current DF 0x42, 0x43*. Typically this rate is larger than the maintenance rate to charge a deeply depleted pack up to the point where it may be fast charged. The desired precharge rate is stored in mA.

If temperature is between the *Charge Inhibit Temp Low (DF0x46)* and the precharge threshold PC (°C), the bq2084-V140 sets *ChargingCurrent()* to *Precharge Current*. The threshold is programmed in the *Precharge Temp DF 0x44*. The maximal value of precharge temperature threshold setting is 12.7°C.

- $\text{Precharge Temp} = \text{PC} (\text{°C}) / 0.1$

The bq2084-V140 also sets *ChargingCurrent()* to the precharge rate if *Voltage()* is less than the value programmed in *Precharge Voltage DF 0x3c-0x3d*. *Precharge Voltage* is programmed in mV.

## Alarm Broadcasts to Smart Charger and Host

If any of the bits 8-15 in *BatteryStatus()* are set, the bq2084-V140 broadcasts an *AlarmWarning()* message to the Host address. If any of the bits 12-15 in *BatteryStatus()* are set, the bq2084-V140 also sends an *AlarmWarning()* message to the Smart Charger address. The bq2084-V140 repeats the *AlarmWarning()* messages every 10 seconds until the alarm bits are cleared. All broadcasts can be disabled by setting *SM* (bit 2) in *Pack Configuration* (DF 0x28).

## Precharge Qualification

The bq2084-V140 sets *ChargingCurrent()* to the precharge rate as programmed in *Precharge Current* DF 0x42-0x43 under the following conditions:

- Voltage: The bq2084-V140 requests the precharge charge rate when any cell voltage drops below the precharge threshold or when the EDV0 threshold is detected. Once requested, a precharge rate remains until all cell voltages increase above the precharge threshold and the EDV0 condition does not exist. The precharge threshold is programmed in *Precharge Voltage* DF 0x3c-0x3d.
- Temperature: The bq2084-V140 requests the precharge rate when *Temperature()* is between *Charge Inhibit Temp Low* (DF 0x46) and the precharge threshold programmed in *Precharge Temp* 0x44. *Temperature()* must be equal to or greater than the precharge threshold + 3°C to allow the fast-charge rate.

## Charge Suspension

The bq2084-V140 may temporarily suspend charge if it detects a charging fault. A charging fault includes the following conditions.

- Overcurrent: An overcurrent condition exists when the bq2084-V140 measures the charge current to be greater than *Charge OC Threshold* (DF 0x12a-0x12b) for a time greater than *Charge OC Time* (DF 0x12c). On detecting an overcurrent condition, the bq2084-V140 turns off the Charge FET. If the Nonremovable Battery bit is not set in *Misc Configuration* DF 0x2a, then the Discharge FET is turned off also. This condition is cleared when the pack is removed or if the Nonremovable Battery bit is set in *Misc Configuration* DF 0x2a and when a discharge current is detected or when *SBS AverageCurrent()* is less than the *ClearFailCurrent* DF 0x61-0x62 for *FaultResetTime* DF 0x130.
- Overtemperature: During charging, an overtemperature condition exists when *Temperature()* is greater than the *Charge Suspend Temp High* value programmed in DF 0x6d, 0x6e. On detecting an overtemperature condition, if enabled by the *OT* bit in *Misc Configuration* DF 0x2a, the bq2084-V140 turns off the Charge and Discharge FETs. The overtemperature condition is cleared when *Temperature()* is equal to or below *Charge Suspend Temp High Reset* (DF 0x6f -0x70). The condition is also cleared if the pack is removed.
- Undertemperature: During charging, an undertemperature condition exists when *Temperature()* is less than the *Charge Suspend Temp Low* in DF 0x79 or *Charge Inhibit Temp Low* in DF 0x46. On detecting an undertemperature condition the bq2084-V140 turns off the Charge FET. The undertemperature condition is cleared when *Temperature()* is greater than *Charge Suspend Temp Low* DF 0x79. The condition is also cleared if the pack is removed. The maximal value of *Charge Suspend Temp Low* setting is 12.7°C.
- Charging exceeds *Maximum Charging Time* in DF 0x10f-0x110. If charging time reaches *Maximum Charge Time*, the Charge FET is turned off. This condition is cleared when the pack detects discharge current or is removed.
- Cell or Pack Overvoltage: An overvoltage condition exist when any cell is greater than *Cell Over Voltage Limit* in DF 0x63-0x64 or if *Voltage()* is greater than *Charging Voltage* in 0x3a-0x3b plus *OvervoltageMargin* in 0x5d-05e. This condition is cleared when the pack is removed or if the *Nonremovable Battery* bit is set in *Misc Configuration* DF 0x2a and when a discharge current is detected or when *SBS AverageCurrent()* is less than the *ClearFailCurrent* DF 0x61-0x62 for *FaultResetTime* DF 0x130. Also, the overvoltage condition must be cleared by *Voltage()* less than *Charging Voltage* in 0x3a-0x3b plus *OvervoltageMargin* in 0x5d-05e and all cell voltages less than *Cell Over Voltage Reset* in DF 0xe0-0xe1.
- Charging is also temporarily suspended during pulse-charging, but this is not considered a fault condition.

## Pulse Charge

The bq2084-V140 is capable of charge control using a pulse-charging algorithm, which allows for charge control in systems where the charger does not control current.

The pulse-charging algorithm uses voltage thresholds and associated time limits for control. These are stored as constants in data flash. The cell voltages are read by the a/d converter every 125 ms during charging. The



voltage used for comparison to the thresholds is the highest cell voltage. These thresholds are set by three data flash constants: *Von Charge Voltage*, *Voff Charge Voltage*, and *Vmax Charge Voltage*. *Von* is the lowest of these, and is the threshold below which the charge FET is turned on, provided the minimum off time (*Pulse Minimum Off Time*) has been met. When the voltage crosses the *Voff* threshold, the maximum on time (*Pulse Maximum On Time*) begins to count down. When this time has expired, the charge FET is turned off. Any time *Vmax* is exceeded, the charge FET is turned off immediately.

The rules are:

1. If charge FET is on:
  - a. If voltage above *Vmax*, turn off.
  - b. Else if voltage above *Voff* and max on time expired, turn off.
  - c. Else count down max on time.
2. If charge FET is off:
  - a. If voltage below *Von* and minimum off time, turn on.
  - b. Else increment off time.

Voltage is sampled every 125 ms; therefore, the minimum off time and maximum on time are in units of 125ms, and pulse on and off times are integral multiples of 125 ms.

The voltage thresholds can be chosen in such a way that they alter the charge mechanism. If *Voff* is set equal to *Vmax*, then every time this threshold is crossed, the charge FET turns off immediately. This effectively disables the maximum charge time, so that the *Voff* threshold has no effect. In this case, the algorithm can be described as having two voltage thresholds, rather than three. The charge FET simply turns on and off as it crosses the two thresholds.

The minimum off time can be similarly disabled by setting it to zero or one. Due to the sample interval, the charge FET always is off for at least one 125-ms cycle.

Thresholds must be chosen carefully to get the desired charging behavior. For example, if *Von* is set below charge voltage minus taper voltage, the pack can never detect full charge. During pulse charging, the charge FET remains off until the cells relax to below the *Von* voltage, which is below the qualification voltage for full charge detection.

During cycle phase of pulse charging (charge FET ON), the voltage can exceed *Voff* value for a period of 125ms until next sample is taken and FET is switched OFF. To prevent cell overvoltage termination, or pack overvoltage termination during this period, values for cell OV should be set larger than voltage reached during this period. Reasonable value of cell OV for given charger current *I* can be calculated, assuming cell impedance of 0.08 Ω/cell, as  $V_{(cell)OV} > V_{on} + 0.08 \times I$ .

Correspondingly, the pack overvoltage margin should be set as  $V_{(margin)} > V_{(cell)OV} \times n - V_{(charge)}$

where: *n* = number of series cells.

When charging begins on a depleted battery pack, the voltage is below *Voff*, and may even stay below *Von* for some time. This means the pack is under constant charge, with no pulsing, for some part of the charge cycle. As the voltage on the cells rises, it crosses the *Voff* threshold (or the *Vmax* threshold if *Voff* is disabled), and the charge FET turns off. Initially, the off time is short, because the cells are only barely over the threshold and is quickly relaxed to below *Von*. As the cell voltages rises, the off times become longer and the on times shorter. This effect, in combination with the reduced current drawn by the cells, results in a gradually declining charge current. Eventually, this current falls below the taper current, and the pack detects the full charge condition and stops charging.

The pulse-charging control operates during normal charging conditions and are overridden in case of a fault condition. Charging is stopped for any fault conditions which may occur, such as overtemperature or overcurrent, without regard to the voltage thresholds or time limits.

### Primary Charge Termination

The bq2084-V140 terminates charge if it detects a charge-termination condition based on current taper. A charge-termination condition includes the following:

The bq2084-V140 detects a current taper termination when the pack voltage is greater than *Charging Voltage* (DF 0x3a-0x3b) minus *Current Taper Qualification Voltage* (DF 0x4d-0x4e) and the *AverageCurrent()* is below the *Current Taper Threshold* (DF 0x4b-0x4c), but greater than the *Charge Detection Current* in DF 0x113-0x114, for a period of *Current Taper Window* (DF 0x4f).

Once the bq2084-V140 detects a Primary Charge Termination, the bq2084-V140 sets the *TERMINATE\_CHARGE\_ALARM* and *FULLY\_CHARGED* bits in *BatteryStatus()*, and turns off the charge FET via the bq29312. The charge FET is turned on when discharge current is detected and is greater than *Discharge Detection Current* (DF 0x115-0x116), to minimize IR losses. The *TERMINATE\_CHARGE\_ALARM* is cleared if charge current is no longer detected or the pack is removed, but returns if charging is attempted while the *FULLY\_CHARGED* bit is set.

The bq2084-V140 clears the *FULLY\_CHARGED* and *TERMINATE\_CHARGE\_ALARM* bit when *RelativeStateOfCharge()* is less than the programmed *Fully Charged Clear %*. See [Table 13](#) for a summary of *BatteryStatus()* alarm and status bit operation.

## Cell Balancing

The bq2084-V140 balances the cells during charge by discharging those cells above the threshold set in *Cell Balance Threshold* DF 0xe8-0xe9, if the maximum difference in cell voltages exceeds the value programmed in *Cell Balance Min* DF 0xec. For cell balancing, the bq2084-V140 measures the cell voltages at an interval set in *Cell Balance Interval* DF 0xed. On the basis of the cell voltages, the bq2084-V140 either selects the appropriate cell to discharge or adjusts the cell balance threshold up by the value programmed in *Cell Balance Window* 0xea-0xeb when all cells exceed the cell balance threshold or the highest cell exceeds the cell balance threshold by the cell balance window.

Cell balancing only occurs when charging current is detected and the cell balance threshold is reset to the value in *Cell Balance Threshold* at the start of every charge cycle. The threshold is only adjusted once during any balance interval.

If the cells are severely imbalanced during charging, where  $V_{CELL(MAX)} - V_{CELL(MIN)} > \text{Cell Imbalance Threshold AND SBS. Current()} > \text{Balance IMAX}$  for a period of *Cell Imbalance time* then the CIM bit in *PF Status* is set.

**Table 6. Cell Balancing and Cell Imbalance Programming**

NAME	DF ADDRESS	DESCRIPTION
Cell Balance Threshold	0xe8-0xe9	Sets the maximum voltage in mV that each cell must achieve to initiate cell balancing. Programming <i>Cell Balance Threshold</i> to 65,535 disables cell balancing.
Cell Balance Min	0xec	Sets in mV the cell differential that must exist to initiate cell balancing
Cell Balance Window	0xea-0xeb	Sets in mV the amount that the cell balance threshold increases during cell balancing
Cell Balance Interval	0xed	Sets the cell balancing time interval in seconds.
Cell Imbalance Threshold	0xee-0xef	Sets the severe imbalance fault limit for cell imbalance detection
Balance IMAX	0xf2-0xf3	Sets the charge current required to allow a cell imbalance to be detected
Cell Imbalance Time	0x134	Sets the time period during which a cell imbalance must be selected for the bq2084 to enter PF mode.

## DISPLAY PORT

### General

The display port drives a 3-, 4-, or 5-LED bar-graph display. The display is activated by a logic signal on the DISP input. The bq2084-V140 can display RM in either a relative or absolute mode with each LED representing a percentage of the full-battery reference. In relative mode, the bq2084-V140 uses FCC as the full-battery reference; in absolute mode, it uses Design Capacity (DC). The DMODE bit in *Pack Configuration* DF 0x28 programs the bq2084-V140 for the absolute or relative display mode. The LED bits program the 3-, 4-, or 5-LED option.

## Activation

The display may be activated at any time by a high-to-low transition on the DISP input. This is usually accomplished with a pullup resistor and a pushbutton switch. Detection of the transition activates the display and starts a 4-s display timer. Reactivation of the display requires that the DISP input return to a logic-high state and then transition low again. The second high-to-low transition can be detected only after the display timer expires. If unused, the DISP input must be pulled up to VCC. If the EDV0 bit is set, the bq2084-V140 disables the LED display.

## Display Modes

In relative mode, each LED output represents 20%, 25%, or 33% of the *RelativeStateOfCharge()* value. In absolute mode, each LED output represents 20%, 25% or 33% of the *AbsoluteStateOfCharge()* value. [Table 7](#) shows the display options for 5 LEDs, for 4 LEDs, [Table 8](#) and [Table 9](#) for 3 LEDs. In either mode, the bq2084-V140 blinks the LED display if *RemainingCapacity()* is less than *Remaining CapacityAlarm()*. The display is disabled if EDV0 = 1.

**Table 7. Display Mode for Five LEDs**

CONDITION RELATIVE OR ABSOLUTE	FIVE-LED DISPLAY OPTION				
StateOfCharge()	LED1	LED2	LED3	LED4	LED5
EDV0 = 1	OFF	OFF	OFF	OFF	OFF
<20%	ON	OFF	OFF	OFF	OFF
≤20%, < 40%	ON	ON	OFF	OFF	OFF
≤40%, < 60%	ON	ON	ON	OFF	OFF
≤60%, < 80%	ON	ON	ON	ON	OFF
≤80%	ON	ON	ON	ON	ON

**Table 8. Display Mode for Four LEDs**

CONDITION RELATIVE OR ABSOLUTE	FOUR-LED DISPLAY OPTION			
StateOfCharge()	LED1	LED2	LED3	LED4
EDV0 = 1	OFF	OFF	OFF	OFF
<25%	ON	OFF	OFF	OFF
≤25%, < 50%	ON	ON	OFF	OFF
≤50%, < 75%	ON	ON	ON	OFF
≤75%	ON	ON	ON	ON

**Table 9. Display Mode for Three LEDs**

CONDITION RELATIVE OR ABSOLUTE	THREE-LED DISPLAY OPTION		
StateOfCharge()	LED1	LED2	LED3
EDV0 = 1	OFF	OFF	OFF
<34%	ON	OFF	OFF
≤34%, < 67%	ON	ON	OFF
≤67%	ON	ON	ON

## LI-ION PROTECTION

The bq2084-V140 along with the bq29312 provides protection for Li-ion batteries, as shown in [Table 10](#). The bq2084-V140 measures temperature and current and uses the bq29312 to measure individual cell voltage. The bq2084-V140 uses this information to determine protection requirements and control the safety FETs or  $\overline{\text{SAFE}}$  output as necessary. It is recommended that the bq2084-V140 protection control be validated by two successive measurements by setting VOD=1 in *Misc Configuration*.

The bq29312 can independently detect and protect the load from an overload (OL) or short circuit in charge (SCC) or discharge (SCD). The bq29312 sets the appropriate FET state and then alerts the bq2084-V140 with the XALERT output whenever a protection threshold is breached and its associated delay time has expired. The bq2084-V140 then determines if and when the FETs should be turned back on.

**Table 10. CVOV and CVUV Flags in PackStatus()**

FLAG	SET CONDITION	DSG FET	CHG FET	CLEAR CONDITION <sup>(1)</sup>
CVOV	Voltage() = ChargingVoltage() + <i>Over Voltage Margin</i>	ON	OFF <sup>(2)</sup>	Voltage() < ChargingVoltage()
	VCELL <sub>(ANY)</sub> = <i>Cell Over Voltage</i>	ON	OFF <sup>(2)</sup>	VCELL <sub>(ALL)</sub> < <i>Cell Over Voltage Reset</i>
CVUV	VCELL <sub>(ANY)</sub> = <i>Cell Under Voltage</i>		<sup>(3)</sup> ON	VCELL <sub>(ALL)</sub> > <i>Cell Under Voltage Reset</i>
	AverageCurrent() < - <i>Over Load Current</i>	OFF <sup>(3)</sup>	ON	AverageCurrent() < - <i>Current Fault Clear Threshold</i>

(1) Clear is detected and controlled by the bq2084-V140.

(2) On if there is a discharge current  $\leq 150$  mA

(3) On if there is a charge current  $\leq 50$  mA

## Protection Configuration

### 1<sup>st</sup> Level Cell Voltage Thresholds

The cell undervoltage (VUV) and overvoltage (VOV) limits are programmed in *Cell Under Voltage* and *Cell Over Voltage* DF 0x65-0x66, DF 0x63-0x64, respectively. Both values are stored in mV. *Cell Over Voltage Reset* DF 0xe0-0xe1 and *Cell Under Voltage Reset* 0xe2-0xe3 set the reset points in mV for these safety parameters.

### Safety Overvoltage Threshold

The safety voltage threshold is programmed in *Safety Over Voltage* DF 0x6b-0x6c. It is stored in mV. Exceeding the Safety Voltage for a period determined by the MISC Config VOD bit causes permanent failure if enabled by PFConfig.

### Overcurrent Thresholds

Discharge current threshold is programmed in *Discharge OC Threshold* DF 0x12d-0x12e. The discharge overcurrent must exist for time programmed in *Discharge OC Time* DF 0x12f. When a discharge overcurrent condition is detected the discharge FET is turned off. Similarly, a charge overcurrent is programmed in *Charge OC Threshold* DF 0x12a-0x12b. The charge overcurrent must exist for the time programmed in *Charge OC Time* DF 0x12c or *Charge OC Time* DF 0x12c. When a charge overcurrent condition is detected, the charge FET is turned off.

### Temperature Thresholds

The Safety Over Temperature in Charge (SOTC) threshold is programmed in *Safety Over Temperature in Charge* DF 0x75-0x76 and *Safety Over Temperature in Discharge* (SOTD) threshold is programmed in *Safety Over Temperature in Discharge* DF 0x77-0x78.

SOTC is stored as *Safety Over Temperature in Charge* = SOTC/0.1 (°C) as an unsigned integer

SOTD is stored as *Safety Over Temperature in Discharge* = SOTD/0.1 (°C) as an unsigned integer. Exceeding the Safety Temperatures for a period exceeding *Over Temperature Time* DF 0x162 causes permanent failure if enabled by PFConfig.

There are also temperature thresholds to disable both charge and discharge FETs and to set the SBS Battery Status Overtemperature bit. The thresholds are set according to whether discharge or charge is detected. The *Charge Suspend Temp High* threshold is stored in DF 0x6d-0x6e with the reset threshold stored in DF 0x6f-0x70. Likewise, the *Over Temperature Discharge* threshold is stored in DF 0x71-0x72 with the reset threshold stored in DF 0x73-0x74. If the OT bit in *Misc Configuration* is set then all temperature protection is disabled except for Safety Over Temperature.

The *Charge Suspend Temp Low* threshold (CSTL) is stored in *Charge Suspend Temp Low* DF 0x79-0x7a and is stored as *Charge Suspend Temp Low* = CSTL/0.1 (°C) as a signed integer. A *Charge Suspend Temp Low* turns off the charge FET. The maximal value of *Charge Suspend Temp Low* setting is 12.7 °C.

### **AFE Configuration**

The AFE protection limits are programmed as specified in the bq29312 data sheet.

*AFE Over Load* DF 0xc5 sets the AFE overload protection threshold.

*AFE Over Load Delay* DF 0xc6 sets the delay timing for overload protection.

*AFE Short Circuit in Charge* DF 0xc7 sets the AFE short circuit in charge protection threshold and delay time.

*AFE Short Circuit in Discharge* DF 0xc8 sets the AFE short circuit in discharge protection threshold and delay time.

SMBus command 0x46 can be used to string-read the AFE RAM with the AFE address 0x00 first, if the bq2084-V140 is not sealed as indicated by bit 5 of PackStatus.

**Table 11. Overcurrent Protection**

<b>FAILURE</b>	<b>FET STATUS</b>	<b>CLEAR CONDITIONS</b>
<b>NR=1</b>		
AFE OLV	CHG on, ZVCHG off, DSG off	Same AFE SCD
AFE SCC	CHG off, ZVCHG off, DSG on	Average Current ( $I$ ) < Clear Fail Current (DF 0x61/2) for Fault Reset Time (DF 0x130), or discharge current > discharge detection current (DF 0x115/6)
AFE SCD	CHG on, ZVCHG off, DSG off	Average Current ( $I$ ) $\leq$ -Clear Fail Current (DF 0x61/2) for Fault Reset Time (DF 0x130), or charge current > charge detection current (DF 0x113/4)
GG Charge OC (set by DF 0x12a to 0x12c)	CHG off, ZVCHG off, DSG on	Same AFE SCC
GG Discharge OC (set by DF 0x12d to 0x12f)	CHG on, ZVCHG off, DSG off	Same AFE SCD
<b>NR=0</b>		
<b>FAILURE</b>	<b>FET STATUS</b>	<b>EXIT CONDITIONS</b>
AFE OLV	All FETs off	RRES=high
AFE SCC	All FETs off	PRES=high
AFE SCD	All FETs off	PRES=high
GG Charge OC (set by DF 0x12a to 0x12c)	All FETs off	PRES=high
GG Discharge OC (set by DF 0x12d to 0x12f)	All FETs off	PRES=high

The AFE protection features can also recover automatically after *AFE Recovery Time* (DF 0x160) if the AFE Recovery Time is set to a nonzero value. When the protection feature is recovered in this manner, it does not re-trigger for *AFE Hold Off Time* (DF 0x161).

### **AFE Integrity Check**

The bq2084-V140 checks the programming of the AFE registers at a period determined by *AFE Check Time* DF 0xfb. The units of the check period are seconds unless the bq2084-V140 is in sleep mode, in which case the period is *AFE Check Time* x *Sleep Current Multiplier* (DF 0xfd). If the data is not correct, the bq2084-V140 increments an internal counter until it reaches the *AFE Fail Limit* (DF 0xe4). Setting *AFE Check Time* to 0 disables this function.

When the internal AFE Fail counter reaches *AFE Fail Limit*, then the AFE bit in PF Status is set.

### **AFE Watchdog Fault and Clear**

The bq29312 has a feature where the 32-kHz output (CLKOUT, pin 35) of the bq2084-V140 is used to drive its internal clock. If this clock fails, a fault is declared in the AFE. See the bq29312 data sheet for further details.

The fault is cleared automatically on return of the 32-kHz input via the bq2084-V140 CLKOUT pin.

### **Permanent Failure Mode ( $\overline{\text{SAFE}}$ Output)**

The  $\overline{\text{SAFE}}$  output of the bq2084-V140 provides an additional level of safety control. The active low safety output can blow a fuse or control another switch on the basis of temperature, pack-voltage cell-voltage, CHG FET Failure, severe cell imbalance, or an integrity check of the AFE and Data Flash configuration registers.

The bq2084-V140 can also activate the  $\overline{\text{SAFE}}$  output and set the PF Flag based on the  $\overline{\text{PFIN}}$  input. If this pin is low for *PFIN Time* seconds  $\pm 1$  s, then the  $\overline{\text{PFIN}}$  bit in PF Status is set.

The  $\overline{\text{SAFE}}$  output can be driven low in any of the following conditions, and the bq2084-V140 sets the *PF Flag* register (DF 0x11e) to 0x66 (011001100). The activation of the  $\overline{\text{SAFE}}$  output and the setting of the *PF Flag* can be enabled or disabled for different safety option per the *PF Config* (DF 0x11f) register settings.

The  $\overline{\text{SAFE}}$  output and PF Flag register can only be cleared using a series of ManufacturerAccess() commands.

**Table 12.  $\overline{\text{SAFE}}$  Activation Conditions<sup>(1)</sup>**

CONDITION	ACTIONS
Voltage() > <i>Safety Over Voltage</i> (DF 0x6b and 0x6c),	SOV and PF set
Temperature() > <i>Safety Over Temperature in Charge</i> (DF 0x75 and 0x76)	SOTC and PF set
Temperature() > <i>Safety Over Temperature in Discharge</i> (DF 0x77 and 0x78)	SOTD and PF set
When Miscellaneous Configuration (0x2a) bit 13 AC is set, and the number of AFE failures has reached the <i>AFE Fail Limit</i> (DF 0xe4)	AFE and PF set
When $V_{\text{CELL}(\text{MAX})} - V_{\text{CELL}(\text{MIN})} > \text{Cell Imbalance Threshold}$ (DF 0xee, 0xef) during charging	CIM and PF set
If charge FET is off, and charge current greater than FET Fail charge current stored in DF 0x125-0x126 for the time determined by FET Fail time in DF 0x129, or if discharge FET is off and discharge current greater than FET Fail discharge current stored in DF 0x127-0x128 for the time determined by FET Fail time in DF 0x129.	FETF and PF set
The $\overline{\text{PFIN}}$ input has detected a low state for <i>PFIN Time</i> in consecutive seconds, as determined by DF 0x120	$\overline{\text{PFIN}}$ , PF set

(1)  $\overline{\text{SAFE}}$  output activated and *PF Flag* set only if enabled by *PF Config* (DF 0x0x11f)

**Permanent Failure Status (PF Status)**

*PF Status* DF 0x11d contains the flags for the cause of the permanent failure mode.

b7	b6	b5	b4	b3	b2	b1	b0
PFF	PFIN	FETF	CIM	AFE	SOTD	SOTC	SOV

**SOV**

The SOV bit indicates a safety overvoltage occurred which if enabled by PF Config would cause the  $\overline{\text{SAFE}}$  output to activate.

- 0 SOV fault not detected (default)
- 1 SOV fault detected

**SOTC**

The SOTC bit indicates a safety overtemperature in charge occurred which if enabled by PF Config would cause the  $\overline{\text{SAFE}}$  output to activate.

- 0 SOTC fault not detected (default)
- 1 SOTC fault detected

**SOTD**

The SOTD bit indicates a safety overtemperature in discharge occurred which if enabled by PF Config would cause the  $\overline{\text{SAFE}}$  output to activate.

- 0 SOTD fault not detected (default)
- 1 SOTD fault detected

**AFE**

The AFE bit indicates an AFE integrity fault state occurred which if enabled by PF Config would cause the  $\overline{\text{SAFE}}$  output to activate.

- 0 AFE is operating correctly (default)
- 1 AFE Integrity check fail limit reached

### CIM

The CIM bit indicates that a severe cell imbalance occurred during charging, which if enabled by PF Config, would cause the  $\overline{\text{SAFE}}$  output to activate.

- 0 All cells are within the *Cell Imbalance Threshold* (default)
- 1 There is a severe cell imbalance

### FETF

The FETF bit indicates a FET or FET driver failure occurred, which if enabled by PF Config would cause the  $\overline{\text{SAFE}}$  output to activate.

- 0 The FETs are operating normally (default)
- 1 The FETs or FET drivers have a fault

### PFIN

The PFIN bit is used to indicate that the output of the 2<sup>nd</sup> level protector has activated.

- 0 The PFIN input is high (default)
- 1 The PFIN input drive and held low by 2<sup>nd</sup> level protector output

### FPP

The FPP bit is used to indicate that current has been detected when the fuse has been set to be blown.

- 0 Current not detected with fuse blown
- 1 Current detected with fuse blown

## Permanent Failure Configuration (PF Config)

*PF Config* DF 0x11f contains the enable/disable configuration that determines if the  $\overline{\text{SAFE}}$  output is activated and the PF Flag set for each possible failure mode.

b7	b6	b5	b4	b3	b2	b1	b0
-	XPFIN	XFETF	XCIM	XAFE	XSOTD	XSOTC	XSOV

### XSOV

The XSOV bit enables or disables the activation of  $\overline{\text{SAFE}}$  and the setting of the PF Flag when *PF Status* SOV is set.

- 0 Activation disabled (default)
- 1 Activation enabled

### XSOTC

The XSOTC bit enables or disables the activation of  $\overline{\text{SAFE}}$  and the setting of the PF Flag when *PF Status* SOTC is set.

- 0 Activation disabled (default)
- 1 Activation enabled

### XSOTD

The XSOTD bit enables or disables the activation of  $\overline{\text{SAFE}}$  and the setting of the PF Flag when *PF Status* SOTD is set.

- 0 Activation disabled (default)
- 1 Activation enabled

### XAFE

The XAFE bit enables or disables the activation of  $\overline{\text{SAFE}}$  and the setting of the PF Flag when *PF Status* AFE is set. Bit 13 of *Miscellaneous Config* DF 0x2a also needs to be set for activation.

- 0 Activation disabled (default)
- 1 Activation enabled

**XCIM**

The XCIM bit enables or disables the activation of  $\overline{\text{SAFE}}$  and the setting of the PF Flag when *PF Status* CIM is set.

- 0 Activation disabled (default)
- 1 Activation enabled

**XFETF**

The XFETF bit enables or disables the activation of  $\overline{\text{SAFE}}$  and the setting of the PF Flag when *PF Status* FETF is set.

- 0 Activation disabled (default)
- 1 Activation enabled

**XPFIN**

The XPFIN bit enables or disables the activation of  $\overline{\text{SAFE}}$  and the setting of the PF Flag when *PF Status* PFIN is set.

- 0 Activation disabled (default)
- 1 Activation enabled

**Permanent Failure Flag (PF Flag)**

*PF Flag* DF 0x11e contains the flag indicating if the  $\overline{\text{SAFE}}$  output has been activated.

STATE	b7	b6	b5	b4	b3	b2	b1	b0
Clear	0	0	0	0	0	0	0	0
Set	0	1	1	0	0	1	1	0

**PF FLAG**

The PF Flag indicates that the  $\overline{\text{SAFE}}$  output of the bq2084-V140 has been activated.

- 0x00  $\overline{\text{SAFE}}$  output high (default)
- 0x66  $\overline{\text{SAFE}}$  output activated

An example circuit using the  $\overline{\text{SAFE}}$  output to blow a fuse is shown in [Figure 2](#).

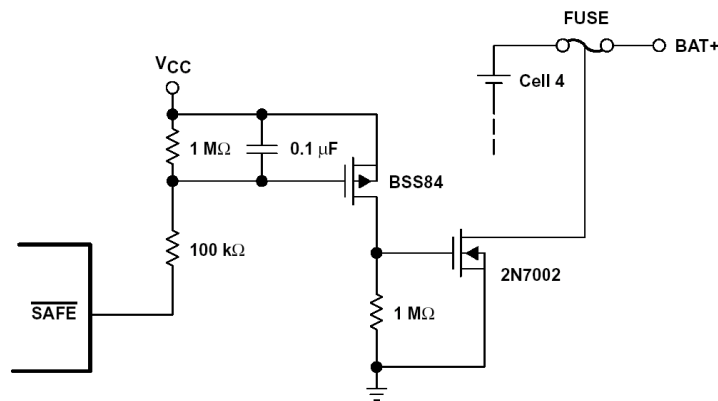

**Figure 2. Example  $\overline{\text{SAFE}}$  Circuit Implementation**



## Low-Power Modes

The bq2084-V140 enters sleep mode when the charge and discharge current is less than the threshold programmed in *Sleep Current Threshold* DF 0xfc, the SMBus lines are low for at least 2s, and bit 12 of *Misc. Configuration* DF 0x2a is set to zero. Additionally, PRES must be pulled high if the NR bit in Misc Config is set to 0. The bq2084-V140 wakes up periodically to monitor voltage and temperature and to apply self-discharge adjustment. The sleep period is set in *Sleep Timer* DF 0xfe. The bq2084-V140 wakes up at a period set by *Sleep Current Multiplier* DF 0xfd multiplied by *Sleep Time* to measure current. The bq2084-V140 comes out of sleep when either of the SMBus lines go high or when the current is measured and it is greater than the *Sleep Current Threshold*.

The sleep current threshold, SLP (mA), is stored in *Sleep Current Thresh* DF 0xfc as:

$$\text{Sleep Current Thresh} = \text{SLP(mA)}/0.5$$

The wake-up period for current measurement, WAT(s), is set using the following formula:

$$\text{Sleep Current Multiplier} \times \text{Sleep Time} = \text{WAT(s)}$$

During sleep mode, both charge and discharge FETs are turned off if the NR bit in Misc Config is cleared. If the bq2084-V140 is in Non-Removable mode where NR=1, then the discharge FET retains its state on entry to sleep.

## Shutdown Mode

The bq2084-V140 goes into shutdown, in which all FETs are turned off and the pack electronics are powered down (including the bq2084-V140), when SBS.Voltage() falls below *Shutdown Voltage* DF 0x7c-0x7d and Voltage at the Pack pin is less than VPACK threshold (DF 0x131, 0x132) both for 2 consecutive samples (1 to 2 s).

Vpack is programmed in units of 0.935 mV/count and has tolerance of  $\pm 6\%$ . For example, to set 12 V as Vpack Threshold, the program value should be  $12000/0.935 = 12834$ .

When the DSG FET is turned on, the pack voltage is close to the battery voltage even with no charger attached. Therefore, to enter shutdown, the Vpack threshold should be set higher than the shutdown threshold plus the tolerance.

The bq2084-V140 can also be instructed to enter Shutdown mode via the *ManufacturerAccess()* command. When the command is sent to the bq2084-V140, the bq29312 is instructed to enter shutdown mode by the bq2084-V140. This forces the chipset into its lowest power mode. The bq2084-V140 does not issue a shutdown command to the AFE unless the pack voltage is less than the Vpack Threshold. Program the Vpack threshold higher than the SBS.Voltage() when ship command is issued. Exit from this mode is only achieved by application of a charger.

After exiting shutdown mode, the bq2084-V140 does not enter the shutdown mode again until the *Shutdown Timer* (DF 0x133, units are seconds) has expired even if the correct conditions are present. After the *Shutdown Timer* has expired, the SMBus command or voltage and current conditions enables the bq2084-V140 to enter shutdown mode.

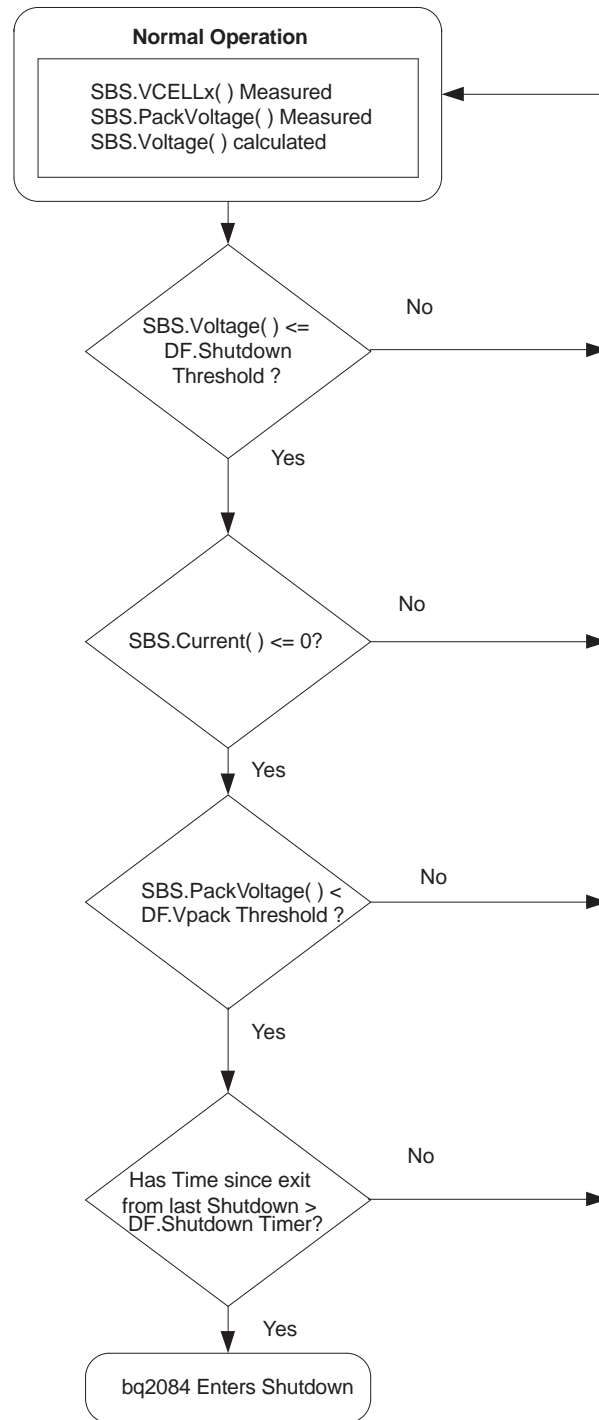

DEFAULTS:

*Non-Removable Pack*

DF.ShutdownVoltage = 2.8 V x Number of Series cells; DF.ShutdownTimer = 2 s

**NOTE:** VpackThreshold must be greater than Shutdown voltage + 6%.

*Removable Pack*

DF.ShutdownVoltage = 2.8 V x Number of Series cells; DF.ShutdownTimer = 20 s

**NOTE:** VpackThreshold must be greater than Shutdown voltage + 6%.

**Figure 3. Shutdown Flow Chart in Normal Operation**

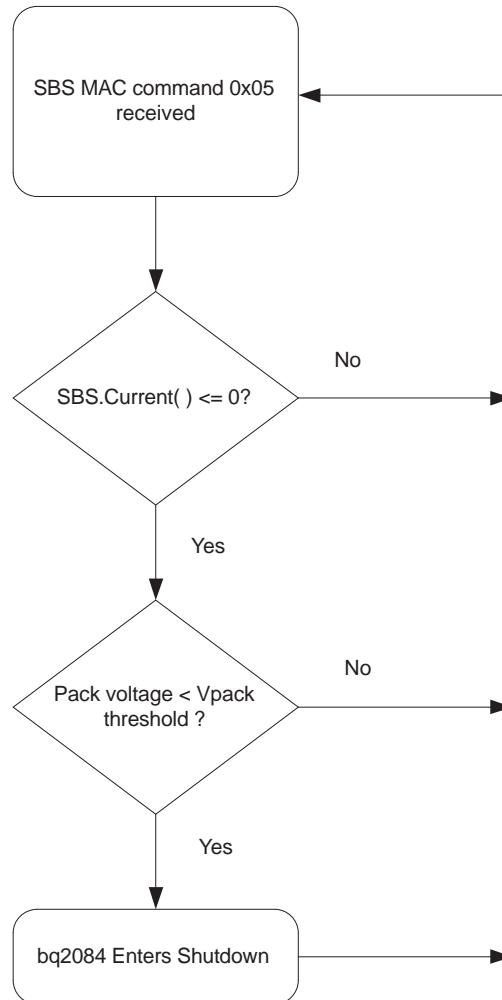

**Figure 4. Shutdown Flow Chart in SBS MAC**

### Reset Conditions

On power up, the entire IC is reset and data is loaded from Data Flash to configure the SBS Data and the battery management solution. On a partial reset (loss of V<sub>CC</sub> but RBI holds RAM valid), a limited number of locations are taken. These actions are the following:

- The AFE registers are rewritten.
- PackStatus() EDV2 flag is cleared.
- BatteryStatus() DISCHARGING flag is cleared.
- The charger and alarm broadcast period is set to 10 seconds between broadcasts.

### COMMUNICATION

The bq2084-V140 includes an SMBus communication port. The SMBus interface is a 2-wire bidirectional protocol using the SMBC (clock) and SMBD (data) pins. The communication lines are isolated from V<sub>CC</sub> and may be pulled up higher than V<sub>CC</sub>. Also, the bq2084-V140 does not pull these lines low if V<sub>CC</sub> to the part is zero. The communication ports allow a host controller, an SMBus compatible device, or other processor to access the memory registers of the bq2084-V140. In this way a system can efficiently monitor and manage the battery.

## SMBus

The SMBus interface is a command-based protocol. A processor acting as the bus master initiates communication to the bq2084-V140 by generating a start condition. A start condition consists of a high-to-low transition of the SMBD line while the SMBC is high. The processor then sends the bq2084-V140 device address of 0001011 (bits 7-1) plus a R/W bit (bit 0) followed by an SMBus command code. The R/W bit (LSB) and the command code instruct the bq2084-V140 to either store the forthcoming data to a register specified by the SMBus command code or output the data from the specified register. The processor completes the access with a stop condition. A stop condition consists of a low-to-high transition of the SMBD line while the SMBC is high. With SMBus, the most-significant bit (MSB) of a data byte is transmitted first. In some instances, the bq2084-V140 acts as the bus master. This occurs when the bq2084-V140 broadcasts charging requirements and alarm conditions to device addresses 0x12 (SBS Smart Charger) and 0x10 (SBS Host Controller.)

## SMBus Protocol

The bq2084-V140 supports the following SMBus protocols:

- Read word
- Write word
- Block read

A processor acting as the bus master uses the three protocols to communicate with the bq2084-V140. The bq2084-V140 acting as the bus master uses the write word protocol.

The SMBD and SMBC pins are open drain and require external pullup resistors. A 1-M $\Omega$  pulldown resistor in the battery pack on SMBC and SMBD is required to ensure the detection of the SMBus off-state, the performance of automatic offset calibration, and the initiation of the low-power sleep mode when the battery pack is removed.

## SMBus Packet Error Checking

The bq2084-V140 supports packet error checking as a mechanism to confirm proper communication between it and another SMBus device. Packet error checking requires that both the transmitter and receiver calculate a packet error code (PEC) for each communication message. The device that supplies the last byte in the communication message appends the PEC to the message. The receiver compares the transmitted PEC to its PEC result to determine if there is a communication error.

## PEC Protocol

The bq2084-V140 can receive or transmit data with or without PEC. [Figure 5](#) shows the communication protocol for the read word, write word, and read block messages without PEC. [Figure 6](#) includes PEC.

In the read word protocol, the bq2084-V140 receives the PEC after the last byte of data from the host. If the host does not support PEC, the last byte of data is followed by a stop condition. After receipt of the PEC, the bq2084-V140 compares the value to its calculation. If the PEC is correct, the bq2084-V140 responds with an ACKNOWLEDGE (ACK). If it is not correct, the bq2084-V140 responds with a NOT ACKNOWLEDGE (NACK) and sets an error code. In the write word and block read, the host generates an ACK after the last byte of data sent by the bq2084-V140. The bq2084-V140 then sends the PEC and the host acting as a master-receiver generates a NACK and a stop condition.

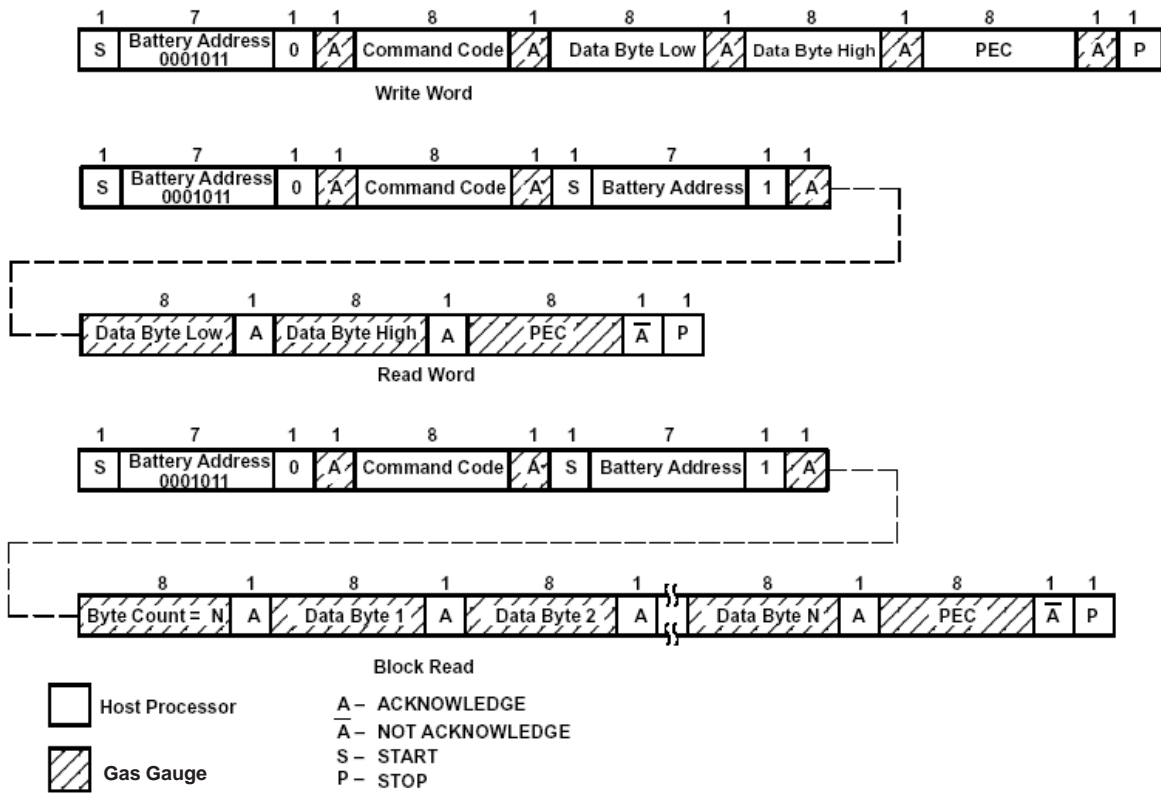

**Figure 5. SMBus Communication Protocol Without PEC**

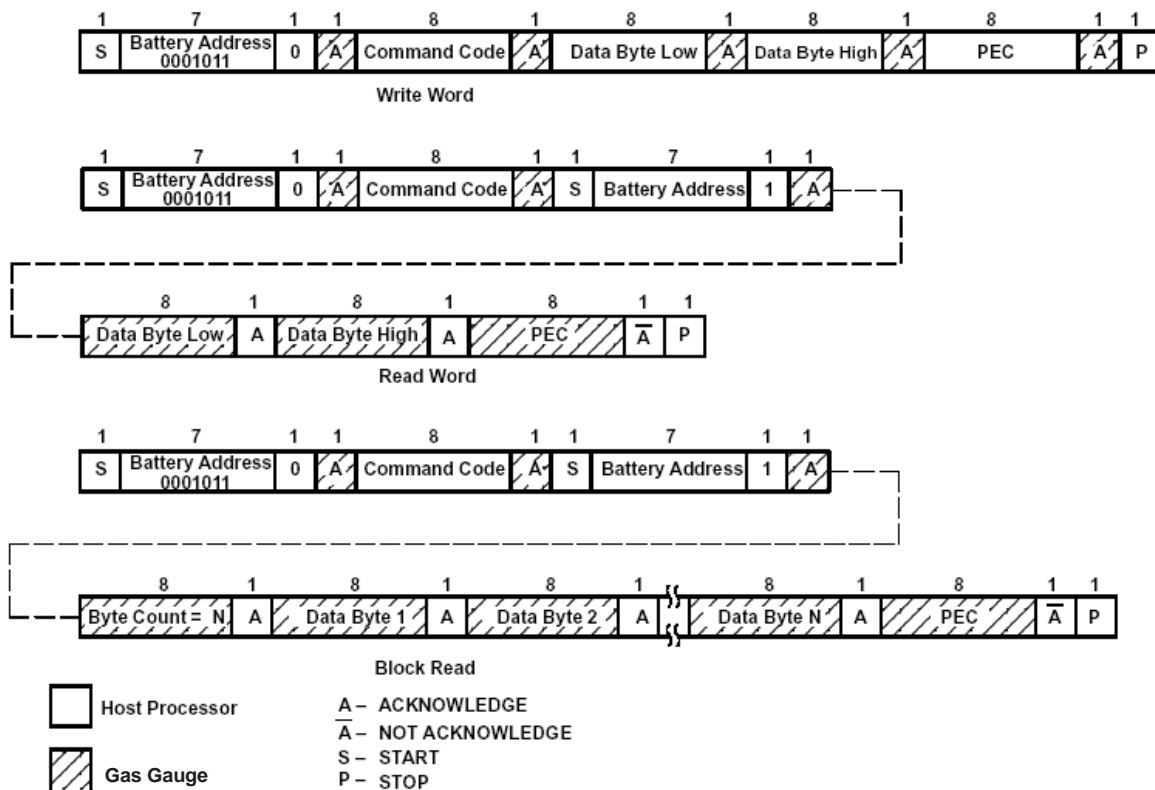

Figure 6. SMBus Communication Protocol With PEC

### PEC Calculation

The basis of the PEC calculation is an 8-bit cyclic redundancy check (CRC-8) based on the polynomial  $C(X) = X^8 + X^2 + X^1 + 1$ . The PEC calculation includes all bytes in the transmission, including address, command, and data. The PEC calculation does not include ACKNOWLEDGE, NOT ACKNOWLEDGE, start, stop, and repeated start bits.

For example, the host requests RemainingCapacity() from the bq2084-V140. This includes the host following the read word protocol. The bq2084-V140 calculates the PEC based on the following 5 bytes of data, assuming the remaining capacity of the battery is 1001 mAh.

- Battery Address with R/W = 0: 0x16
- Command Code for RemainingCapacity(): 0x0f
- Battery Address with R/W = 1: 0x17
- RemainingCapacity(): 0x03e9

For 0x160f17e903, the bq2084-V140 transmits a PEC of 0xe8 to the host.

### PEC Enable in Master Mode

The PEC for master mode broadcasts to the charger, host, or both can be enabled/disabled with the combination of the bits HPE and CPE in *Pack Configuration* DF 0x28.

### SMBus On- and Off-State

The bq2084-V140 detects whether the SMBus enters the Off State by monitoring the SMBC and SMBD lines. When both signals are continually low for at least 2.0 s, the bq2084-V140 detects the Off State. When the SMBC and SMBD lines go high, the bq2084-V140 detects the On State and can begin communication within 1 ms. One-MΩ pull-down resistors on SMBC and SMBD are recommended for reliable Off State detection.

## Command Codes

The SMBus command codes are in (). *Temperature()*, *Voltage()*, *Current()*, and *AverageCurrent()*, performance specifications are at bq29312 regulated VCC (V(REG)) and a temperature of -20°C to 85°C.

### Manufacturer Access() (0x00)

**Description:** This function provides writable command codes to control the bq2084-V140 during normal operation and pack manufacture. Writing the command code to SMB command 0x00 causes the following reads with the SMB command 0x00 to return the word indicated in the table. The following commands are available:

COMMAND CODE	NAME	DESCRIPTION
0x0001	Device Type	Returns IC part number so it can be read, i.e., 2084 (0x0824)
0x0002	Firmware Rev	Returns firmware version so it can be read
0x0003	EDV Level	Returns the pending end-of-discharge voltage level so it can be read
0x0004	Manufacturer Status	Returns the battery system status so it can read
0x0005	SHIP Command	Instructs the bq2084-V140 to instruct the bq29312 to enter ship mode
0x062b	Seal	Instructs the bq2084-V140 to restrict access to those functions listed in <a href="#">Table 3</a> . The bq2084-V140 completes the seal function and clears ManufacturerAccess().

The Manufacture Status word is defined as:

<b>b15</b>	<b>b14</b>	<b>b13</b>	<b>b12</b>	<b>b11</b>	<b>b10</b>	<b>b9</b>	<b>b8</b>
FET1	FET0	PF1	PF0	STATE3	STATE2	STATE1	STATE0
<b>b7</b>	<b>b6</b>	<b>b5</b>	<b>b4</b>	<b>b3</b>	<b>b2</b>	<b>b1</b>	<b>b0</b>
0	0	0	0	1	0	1	0

### FET1, FET0

Indicated the state of the charge and discharge FETs

- 0,0 Both charge and discharge FETs are on.
- 0,1 Charge FET is off, discharge FET is on.
- 1,0 Both charge and discharge FETs are off.
- 1,1 Charge FET is on, discharge FET is off.

### PF1, PF0

Indicates permanent failure cause when permanent failure indicated by STATE3-STATE0

- 0,0 Fuse is blown
- 0,1 Cell imbalance failure
- 1,0 Safety voltage failure
- 1,1 FET failure

### STATE3, STATE2, STATE1, STATE0

Indicates battery state as defined in the State and Status bit Summary.

**Purpose:** The ManufacturerAccess() function provides the system host access to bq2084-V140 functions that are not defined by the SBD.

**SMBus protocol:** Read or write word

**Input/Output:** Word

**Table 13. State and Status Bit Summary**

State	MAC Mode (MSB)	CC()	CV()	CHG FET <sup>(1)</sup>	DSG FET	ZVCHG FET	FUSE	Power Mode
wakeup	0x00 Wake up	0	0	off <sup>(2)</sup>	on	on <sup>(3)</sup>	ok	normal
precharge	0x03 Precharge	PC	CV	of <sup>(2)f</sup>	on	on <sup>(4)</sup>	ok	normal
chargesusp	0x04 Charge Suspension	FC	CV	off	on	off	ok	normal
terminatecharge	0x07 Charge Terminate	MC	CV	off	on	off	ok	normal
normalcharge	0x05 Charge	FC <sup>(5)</sup>	CV	on	on	off	ok	normal
provisionalcharge	0x01 Normal	0	0	off	on	off	ok	normal
normaldischarge		FC	CV	on	on	off	ok	normal
depleted	0x0e System Present	PC	CV	off	off	off	ok	normal
depleted_ac		PC	CV	off	off	off <sup>(4)</sup>	ok	normal
overheatdischarge		FC	CV	off	off	off	ok	normal
overheatcharge		FC	CV	off	off	off	ok	normal
battfail_overcharge		0	0	off	on	off	ok	normal
battfail_lowtemp		0	0	off	on	off	ok	normal
battfail_chargeterminate	0x08 Fault Charge Terminate	0	0	off	on	off	ok	normal
battfail_afe_chg	0x0c Battery Failure	0	0	off	of <sup>(6)f</sup>	off	ok	normal
battfail_afe_dsg		FC	CV	off <sup>(6)</sup>	off	off	ok	normal
battfail_chg	0x0a Over Current	0	0	off	off <sup>(6)</sup>	off	ok	normal
battfail_dsg		FC	CV	off <sup>(6)</sup>	off	off	ok	normal
removed	0x0f Battery Out	FC	CV	off	off	off	ok	normal
sleep	0x0d Sleep	0	0	off	off <sup>(7)</sup>	off	ok	low
permanent_failure	0x09 Permanent Failure	0	0	off	off	off	blow	low

- (1) CHG FET always on if discharge current greater than Discharge Detection Current (DF 0x115, 0x116)
- (2) On if FET Config = 01 (Common precharge, charge FET)
- (3) ZVCHG FET on, OD FET off if FET Config = 00 or 02 (ZVCHG FET or precharge FET)
- (4) ZVCHG FET on, OD FET off if FET Config = 00 (ZVCHG FET), or ZVCHG FET off, OD FET on if FET Config = 02 (precharge FET)
- (5) 0 if CVOV or PC is not CVOV and minimum cell voltage is less than the precharge cell voltage threshold
- (6) If MiscConfig.Nonremoveable Battery is set, then FET is on.

**RemainingCapacityAlarm() (0x01)**

**Description:** Sets or gets the low-capacity threshold value. Whenever the *RemainingCapacity()* falls below the low-capacity value, the bq2084-V140 sends *AlarmWarning()* messages to the SMBus host with the *REMAINING\_CAPACITY\_ALARM* bit set. A low-capacity value of 0 disables this alarm. The bq2084-V140 initially sets the low-capacity value to *Remaining Capacity Alarm* value programmed in DF 0x02-0x03. The low-capacity value remains unchanged until altered by the *RemainingCapacityAlarm()* function. The low-capacity value may be expressed in either current (mA) or power (10 mWh) depending on the setting of the *BatteryMode()* *CAPACITY\_MODE* bit.

**Purpose:** The *RemainingCapacityAlarm()* function can be used by systems that know how much power they require to save their operating state. It enables those systems to more finely control the point at which they transition into suspend or hibernate state. The low-capacity value can be read to verify the value in use by the bq2084-V140 low-capacity alarm.

**SMBus protocol:** Read or write word

**Input/Output:** Unsigned integer-value below which Low Capacity messages are sent.

	BATTERY MODES	
	CAPACITY_MODE BIT = 0	CAPACITY_MODE BIT = 1
Units	mAh at C/5	10 mWh at P/5
Range	0-65,535 mAh	0-65,535 10 mWh
Granularity	Not applicable	
Accuracy	See RemainingCapacity()	



### RemainingTimeAlarm() (0x02)

**Description:** Sets or gets the *Remaining Time Alarm* value. Whenever the *AverageTimeToEmpty()* falls below the remaining time value, the bq2084-V140 sends *AlarmWarning()* messages to the SMBus host with the *REMAINING\_TIME\_ALARM* bit set. A remaining time value of 0 effectively disables this alarm. The bq2084-V140 initially sets the remaining time value to the *Remaining Time Alarm* value programmed in DF 0x00-0x01. The remaining time value remains unchanged until altered by the *RemainingTimeAlarm()* function.

**Purpose:** The *RemainingTimeAlarm()* function can be used by systems that want to adjust when the remaining time alarm warning is sent. The remaining time value can be read to verify the value in use by the bq2084-V140 *RemainingTimeAlarm()*.

**SMBus protocol:** Read or write word

**Input/Output:** Unsigned integer—the point below which remaining time messages are sent.

**Units:** Minutes

**Range:** 0 to 65,535 minutes

**Granularity:** Not applicable

**Accuracy:** See *AverageTimeToEmpty()*.

### BatteryMode() (0x03)

**Description:** Selects the various battery operational modes and reports the battery's mode and requests.

Defined modes include

- Whether the battery capacity information is specified in units of mAh or 10 mWh (*CAPACITY\_MODE* bit)
- Whether the *ChargingCurrent()* and *ChargingVoltage()* values are broadcast to the smart battery charger when the *CHARGER\_MODE* bit is set.
- Whether all broadcasts to the smart battery charger and host are disabled

The defined request condition is the battery requesting a conditioning cycle (*RELEARN\_FLAG*).

**Purpose:** The *CAPACITY\_MODE* bit allows power management systems to best match their electrical characteristics with those reported by the battery. For example, a switching power supply represents a constant power load, whereas a linear supply is better represented by a constant current model. The *CHARGER\_MODE* bit allows a SMBus host or smart battery charger to override the smart battery desired charging parameters by disabling the bq2084-V140 broadcasts. The *RELEARN\_FLAG* bit allows the bq2084-V140 to request a conditioning cycle.

**SMBus protocol:** Read or write word

**Input/Output:** Unsigned integer—bit mapped—see [Table 14](#).

**Units:** Not applicable

**Range:** 0-1

**Granularity:** Not applicable

**Accuracy:** Not applicable

The *BatteryMode()* word is divided into two halves, the MSB (bits 8-15) which is read/write and the LSB (bits 0-7) which is read only. The bq2084-V140 forces bits 0-6 to zero and prohibits writes to bit 7.

[Table 14](#) summarizes the meanings of the individual bits in the *BatteryMode()* word. Specified default values, where applicable, are noted. *INTERNAL\_CHARGE\_CONTROLLER* bit is not used by the bq2084-V140.

*PRIMARY\_BATTERY\_SUPPORT* bit is not used by the bq2084-V140.

*RELEARN\_FLAG* bit set indicates that the bq2084-V140 is requesting a capacity relearn cycle for the battery. The bq2084-V140 sets the *RELEARN\_FLAG* on a full reset and if it detects 20-cycle counts without an FCC update. The bq2084-V140 clears this flag after a learning cycle has been completed.

*CHARGE\_CONTROLLER\_ENABLED* bit is not used by the bq2084-V140. The bq2084-V140 forces this bit to zero.

`PRIMARY_BATTERY` bit is not used by the bq2084-V140. The bq2084-V140 forces this bit to zero.

**Table 14. Battery Mode Bits and Values**

Battery Mode() BITS	BITS USED	FORMAT	ALLOWABLE VALUES
INTERNAL_CHARGE_CONTROLLER	0	Read only bit flag	1 - always one
PRIMARY_BATTERY_SUPPORT	1	Read only bit flag	0 - always zero
Reserved	2-6		0 - always zero
RELEARN_FLAG	7	Read only bit flag	0—Battery OK1—Relearn cycle requested
CHARGE_CONTROLLER_ENABLED	8	R/W bit flag	Not used
PRIMARY_BATTERY	9	R/W bit flag	Not used
Reserved	10-12		0 - always zero
ALARM_MODE	13	R/W bit flag	0—Enable alarm broadcast (default)1—Disable alarm broadcast
CHARGER_MODE	14	R/W bit flag	0—Enable charging broadcast (default)1—Disable charging broadcast
CAPACITY_MODE	15	R/W bit flag	0—Report in mA or mAh (default)1—Report in 10 mW or 10 mWh

`ALARM_MODE` bit is set to disable the bq2084-V140s ability to master the SMBus and send *AlarmWarning()* messages to the SMBus host and the smart battery charger. When set, the bq2084-V140 does *not* master the SMBus, and *AlarmWarning()* messages are not sent to the SMBus host and the smart battery charger for a period of no more than 60s and no less than 59s. When cleared (default), the smart battery sends the *AlarmWarning()* messages to the SMBus host and the smart battery charger any time an alarm condition is detected.

- The ALARM broadcast does not occur more often than once every 10 s. Whenever the BATTERY\_MODE command is received, the bq2084-V140 resets the bit and starts or restarts a 60-s (nominal) timer. After the timer expires, the bq2084-V140 automatically enables alarm broadcasts to ensure that the accidental deactivation of broadcasts does not persist. An SMBus host that does not want the bq2084-V140 to be a master on the SMBus must therefore continually set this bit at least once per 59 s to keep the bq2084-V140 from broadcasting alarms.
- The `ALARM_MODE` bit defaults to a cleared state when the bq2084-V140 enters SLEEP mode.
- The condition of the `ALARM_MODE` bit does *not* affect the operation or state of the `CHARGER_MODE` bit, which is used to prevent broadcasts of *ChargingCurrent()* and *ChargingVoltage()* to the smart battery charger. `CHARGER_MODE` bit enables or disables the bq2084-V140's transmission of *ChargingCurrent()* and *ChargingVoltage()* messages to the smart battery charger. When set, the bq2084-V140 does *not* transmit *ChargingCurrent()* and *ChargingVoltage()* values to the smart battery charger. When cleared, the bq2084-V140 transmits the *ChargingCurrent()* and *ChargingVoltage()* values to the smart battery charger. The `CHARGER_MODE` bit defaults to a cleared state when the bq2084-V140 enters SLEEP mode.

`CAPACITY_MODE` bit indicates if capacity information is reported in mA/mAh or 10 mW/10 mWh. When set, the bq2084-V140 reports capacity information in 10 mW/10 mWh as appropriate. When cleared, the bq2084-V140 reports capacity information in mA/mAh as appropriate. The `CAPACITY_MODE` bit defaults to a cleared state when the bq2084-V140 enters SLEEP mode.

The following functions are changed to accept or return values in mA/mAh or 10 mW/10 mWh depending on the `CAPACITY_MODE` bit:

- *RemainingCapacityAlarm()*
- *AtRate()*
- *RemainingCapacity()*
- *FullChargeCapacity()*
- *DesignCapacity()*

The following functions are calculated on the basis of capacity and may be calculated differently depending on the `CAPACITY_MODE` bit:

- *AtRateOK()*
- *AtRateTimeToEmpty()*

- *AtRateTimeToFull()*
- *RunTimeToEmpty()*
- *AverageTimeToEmpty()*
- *AverageTimeToFull()*
- *Remaining Time Alarm()*
- *BatteryStatus()*

The bq2084-V140 updates the non-AtRate related register values immediately after changing the state of the *CAPACITY\_MODE* bit. The *AtRate()* values are updated after the next *AtRate()* value is written to the bq2084-V140 (or after the next 1-s scheduled refresh calculation).

### AtRate() (0x04)

**Description:** The *AtRate()* function is the first half of a two-function call-set used to set the *AtRate* value used in calculations made by the *AtRateTimeToFull()*, *AtRateTimeToEmpty()*, and *AtRateOK()* functions. The *AtRate* value may be expressed in either current (mA) or power (10 mW) depending on the setting of the *BatteryMode()* *CAPACITY\_MODE* bit.

**Purpose:** Because the *AtRate()* function is the first half of a two-function call-set, it is followed by the second function of the call-set that calculates and returns a value based on the *AtRate* value and the battery's present state.

- When the *AtRate()* value is positive, the *AtRateTimeToFull()* function returns the predicted time to full charge at the *AtRate* value of charge.
- When the *AtRate()* value is negative, the *AtRateTimeToEmpty()* function returns the predicted operating time at the *AtRate* value of discharge.
- When the *AtRate()* value is negative, the *AtRateOK()* function returns a Boolean value that predicts the battery's ability to supply the *AtRate* value of *additional* discharge energy (current or power) for 10 seconds.

The default value for *AtRate()* is zero.

**SMBus protocol:** Read or write word

**Input/Output:** Signed integer—charge or discharge; the *AtRate()* value is positive for charge, negative for discharge, and zero for neither (default).

	BATTERY MODES	
	CAPACITY_MODE BIT = 0	CAPACITY_MODE BIT = 1
Units	mA	10 mW
Charge range	1 to 32,767 mA	1 to 32,767 10 mW
Discharge range	-1 to -32,768 mA	-1 to -32,768 10 mW
Granularity	1 Unit	
Accuracy	NA	

### AtRateTimeToFull() (0x05)

**Description:** Returns the predicted remaining time to fully charge the battery at the *AtRate()* value (mA).

**Purpose:** The *AtRateTimeToFull()* function is part of a two-function call-set used to determine the predicted remaining charge time at the *AtRate* value in mA. The bq2084-V140 updates *AtRateTimeToFull()* within 5 ms after the SMBus host sets the *AtRate* value. The bq2084-V140 automatically updates *AtRateTimeToFull()* based on the *AtRate()* value every 1 s.

**SMBus protocol:** Read word

**Output:** Unsigned integer—predicted time in minutes to fully charge the battery.

**Units:** Minutes

**Range:** 0 to 65,534 min

**Granularity:** 2 min or better

**Accuracy:**  $\pm \text{MaxError()} * \text{FullChargeCapacity()} / |\text{AtRate}()|$

**Invalid Data Indication:** 65,535 indicates the  $\text{AtRate} = 0$ .

#### **AtRateTimeToEmpty() (0x06)**

**Description:** Returns the predicted remaining operating time if the battery is discharged at the  $\text{AtRate}()$  value.

**Purpose:** The  $\text{AtRateTimeToEmpty}()$  function is part of a two-function call-set used to determine the remaining operating time at the  $\text{AtRate}()$  value. The bq2084-V140 updates  $\text{AtRateTimeToEmpty}()$  within 5 ms after the SMBus host sets the  $\text{AtRate}()$  value. The bq2084-V140 automatically updates  $\text{AtRateTimeToEmpty}()$  based on the  $\text{AtRate}()$  value every 1 s.

**SMBus protocol:** Read word

**Output:** Unsigned integer—estimated operating time left.

**Units:** Minutes

**Range:** 0 to 65,534 min

**Granularity:** 2 min or better

**Accuracy:**  $-0, +\text{MaxError}() \times \text{FullChargeCapacity}() / |\text{AtRate}()|$

**Invalid Data Indication:** 65,535 indicates  $\text{AtRate} = 0$ .

#### **AtRateOK() (0x07)**

**Description:** Returns a Boolean value that indicates whether or not the battery can deliver the  $\text{AtRate}()$  value of *additional* energy for 10 s. If the  $\text{AtRate}$  value is zero or positive, the  $\text{AtRateOK}()$  function ALWAYS returns OK (logic 1).

**Purpose:** The  $\text{AtRateOK}()$  function is part of a two-function call-set used by power management systems to determine if the battery can safely supply enough energy for an additional load. The bq2084-V140 updates  $\text{AtRateOK}()$  within 5 ms after the SMBus host sets the  $\text{AtRate}()$  value. The bq2084-V140 automatically updates  $\text{AtRateOK}()$  based on the  $\text{AtRate}()$  value every 1 second.

**SMBus protocol:** Read word

**Output:** Boolean—indicates if the battery can supply the *additional* energy requested.

**Units:** Boolean

**Range:** 1, 0

**Granularity:** Not applicable

**Accuracy:** Not applicable

#### **Temperature() (0x08)**

**Description:** Returns the temperature (K) measured by the bq2084-V140.

**Purpose:** The  $\text{Temperature}()$  function provides accurate cell temperatures for use by battery chargers and thermal management systems. A battery charger can use the temperature as a safety check. Thermal management systems may use the temperature because the battery is one of the largest thermal sources in a system.

**SMBus protocol:** Read word

**Output:** Unsigned integer—cell temperature in tenth-degree Kelvin increments.

**Units:**  $0.1^\circ\text{K}$

**Range:** 0 to  $+6553.5^\circ\text{K}$  {real range}

**Granularity:**  $0.1^\circ\text{K}$

**Accuracy:**  $\pm 1.5^\circ\text{K}$  (from ideal Semitec 103AT thermistor performance, after calibration)

**Voltage() (0x09)**

**Description:** Returns the cell-pack voltage (mV).

**Purpose:** The *Voltage()* function provides power management systems with an accurate battery terminal voltage. Power management systems can use this voltage, along with battery current information, to characterize devices they control. This ability helps enable intelligent, adaptive power-management systems.

**SMBus protocol:** Read word

**Output:** Unsigned integer—battery terminal voltage in mV.

**Units:** mV

**Range:** 0 to 20,000 mV

**Granularity:** 1 mV

**Accuracy:**  $\pm 0.25\%$  (after calibration)

**Current() (0x0a)**

**Description:** Returns the current being supplied (or accepted) by the battery (mA).

**Purpose:** The *Current()* function provides a snapshot for the power management system of the current flowing into or out of the battery. This information is of particular use in power-management systems because they can characterize individual devices and tune their operation to actual system power behavior.

**SMBus protocol:** Read word

**Output:** Signed integer—charge/discharge rate in mA increments: positive for charge, negative for discharge.

**Units:** mA

**Range:** -32,768 to 32,767 mA

**Granularity:** 1 mA

**Accuracy:** 0.25% or 5 mA, whichever is greater

**AverageCurrent() (0x0b)**

**Description:** Returns a value that approximates a one-minute rolling average of the current being supplied (or accepted) through the battery terminals (mA). *AverageCurrent()* is implemented as a single pole IIR filter with a 14.5-s time constant.

**Purpose:** The *AverageCurrent()* function provides the average current flowing into or out of the battery for the power management system.

**SMBus protocol:** Read word

**Output:** Signed integer—charge/discharge rate in mA increments: positive for charge, negative for discharge.

**Units:** mA

**Range:** -32,768 to 32,767 mA

**Granularity:** 1 mA

**Accuracy:** 0.25% or 5 mA, whichever is greater

**MaxError() (0x0c)**

**Description:** Returns the expected margin of error (%) in the state of charge calculation. For example, when *MaxError()* returns 10% and *RelativeStateOfCharge()* returns 50%, the *RelativeStateOfCharge()* is more likely between 50% and 60%. The bq2084-V140 sets *MaxError()* to 100% on a full reset. The bq2084-V140 sets *MaxError()* to 2% on completion of a learning cycle, unless the bq2084-V140 limits the learning cycle to the +512/-256 mAh maximum adjustment values. If the learning cycle is limited, the bq2084-V140 sets *MaxError()* to 8% unless *MaxError()* was already below 8%. In this case, *MaxError()* does not change. The bq2084-V140 increments *MaxError()* by 1% after four increments of *CycleCount()* without a learning cycle. If voltage-based corrections are applied to the coulomb counter, *MaxError()* is set to 25%.

**Purpose:** The *MaxError()* function has real value in two ways: first, to give the user a confidence level about the state of charge and second, to give the power management system information about how aggressive it should be, particularly as the battery nears the end of its life.

**SMBus protocol:** Read word

**Output:** Unsigned integer—percent uncertainty for selected information.

**Units:** %

**Range:** 2-100%

**Granularity:** 1%

**Accuracy:** Not applicable

#### **RelativeStateOfCharge() (0x0d)**

**Description:** Returns the predicted remaining battery capacity expressed as a percentage of *FullChargeCapacity()* (%).

**Purpose:** The *RelativeStateOfCharge()* function is used to estimate the amount of charge remaining in the battery relative to the last learned capacity.

**SMBus protocol:** Read word

**Output:** Unsigned integer-percent of remaining capacity.

**Units:** %

**Range:** 0-100%

**Granularity:** 1%

**Accuracy:** -0, +MaxError()

#### **AbsoluteStateOfCharge()(0x0e)**

**Description:** Returns the predicted remaining battery capacity expressed as a percentage of *DesignCapacity()* (%). Note that *AbsoluteStateOfCharge()* can return values greater than 100%.

**Purpose:** The *AbsoluteStateOfCharge()* function is used to estimate the amount of charge remaining in the battery relative to the nominal or *DesignCapacity()*.

**SMBus protocol:** Read word

**Output:** Unsigned integer—percent of remaining capacity.

**Units:** %

**Range:** 0-100+%

**Granularity:** 1%

**Accuracy:** -0, +MaxError()

#### **RemainingCapacity() (0x0f)**

**Description:** Returns the predicted charge or energy remaining in the battery. The *RemainingCapacity()* value is expressed in either charge or energy, depending on the setting of the *BatteryMode()* *CAPACITY\_MODE* bit.

**Purpose:** The *RemainingCapacity()* function returns the battery's remaining capacity. This information is a numeric indication of remaining charge or energy given by the *AbsoluteStateOfCharge()* or *RelativeStateOfCharge()* functions and may be in a better form for use by power management systems.

**SMBus protocol:** Read word

**Output:** Unsigned integer—remaining charge in units of mAh or 10 mWh.

	BATTERY MODES	
	CAPACITY_MODE BIT = 0	CAPACITY_MODE BIT = 1
Units	mAh	10 mWh
Range	0-65,535 mAh	0-65,535 10 mWh
Granularity	mAh	10 mWh
Accuracy	-0, +MaxError() *	FullChargeCapacity()

### FullChargeCapacity() (0x10)

**Description:** Returns the predicted pack capacity when it is fully charged. The *FullChargeCapacity()* value is expressed in either current (mAh at a C/5 discharge rate) or power (10 mWh at a P/5 discharge rate) depending on the setting of the *BatteryMode()* CAPACITY\_MODE bit.

**Purpose:** The *FullChargeCapacity()* function provides a means of understanding the tank size of the battery. This information, along with information about the original capacity of the battery, indicates battery wear.

**SMBus protocol:** Read word

**Output:** Unsigned integer—estimated full-charge capacity in units of mAh or 10 mWh.

	BATTERY MODES	
	CAPACITY_MODE BIT = 0	CAPACITY_MODE BIT = 1
Units	mAh	10 mWh
Range	0-65,535 mAh	0-65,535 10 mWh
Granularity	mAh	10 mWh
Accuracy	-0, +MaxError() × FullChargeCapacity()	

### RunTimeToEmpty() (0x11)

**Description:** Returns the predicted remaining battery life at the present rate of discharge (minutes). The *RunTimeToEmpty()* value is calculated based on either current or power depending on the setting of the *BatteryMode()* CAPACITY\_MODE bit.

**Purpose:** The *RunTimeToEmpty()* provides the power management system with information about the relative gain or loss in remaining battery life in response to a change in power policy. This information is **not** the same as the *AverageTimeToEmpty()*, which is not suitable to determine the effects that result from a change in power policy.

**SMBus protocol:** Read word

**Output:** Unsigned integer—minutes of operation left.

**Units:** Minutes

**Range:** 0 to 65,534 min

**Granularity:** 2 min or better

**Accuracy:** -0, +MaxError() × FullChargeCapacity() / Current()

**Invalid Data Indication:** 65,535 indicates battery is not being discharged.

### AverageTimeToEmpty() (0x12)

**Description:** Returns a predicted remaining battery life (minutes), based on *AverageCurrent*. The *AverageTimeToEmpty()* value is calculated based on either current or power depending on the setting of the *BatteryMode()* CAPACITY\_MODE bit.

**Purpose:** The *AverageTimeToEmpty()* displays state-of-charge information in a more useful way. It averages the instantaneous estimations so that the remaining time does not appear to jump around.

**SMBus protocol:** Read word

**Output:** Unsigned integer—minutes of operation left.

**Units:** Minutes

**Range:** 0 to 65,534 min

**Granularity:** 2 min or better

**Accuracy:** -0, + $MaxError() * FullChargeCapacity() / AverageCurrent()$

**Invalid Data Indication:** 65,535 indicates battery is not being discharged.

#### **AverageTimeToFull() (0x13)**

**Description:** Returns a predicted remaining time until the battery reaches full charge (minutes), based on *AverageCurrent*.

**Purpose:** The *AverageTimeToFull()* function can be used by the SMBus host's power management system to aid in its policy. It may also be used to find out how long the system must be left on to achieve full charge.

**SMBus protocol:** Read word

**Output:** Unsigned integer—remaining time in minutes.

**Units:** Minutes

**Range:** 0 to 65,534 minutes

**Granularity:** 2 minutes or better

**Accuracy:** -0, + $MaxError() * FullChargeCapacity() / AverageCurrent()$

**Invalid Data Indication:** 65,535 indicates the battery is not being charged.

#### **ChargingCurrent() (0x14)**

**Description:** Returns the desired charging rate in mA.

**Purpose:** The *ChargingCurrent()* function sets the maximum charge current of the battery. The *ChargingCurrent()* value should be used in combination with the *ChargingVoltage()* value to set the charger's operating point. Together, these functions permit the bq2084-V140 to dynamically control the charging profile (current/voltage) of the battery. The bq2084-V140 can effectively turn off a charger by returning a value of 0 for this function. The charger may be operated as a constant-voltage source above its maximum regulated current range by returning a *ChargingCurrent()* value of 65,535.

**SMBus protocol:** Read word

**Output:** Unsigned integer—maximum charger output current in mA.

**Units:** mA

**Range:** 0 to 65,535 mA

**Granularity:** 1 mA

**Accuracy:** Not applicable

**Invalid Data Indication:** 65,535 indicates that a charger should operate as a voltage source outside its maximum regulated current range.

#### **ChargingVoltage() (0x15)**

**Description:** Returns the desired charging voltage in mV.

**Purpose:** The *ChargingVoltage()* function sets the maximum charge voltage of the battery. The *ChargingVoltage()* value should be used in combination with the *ChargingCurrent()* value to set the charger's operating point. Together, these functions permit the bq2084-V140 to dynamically control the charging profile (current/voltage) of the battery. The charger may be operated as a constant-current source above its maximum regulated voltage range by returning a *ChargingVoltage()* value of 65,535.

**SMBus protocol:** Read word

**Output:** Unsigned integer—charger output voltage in mV.



**Units:** mV

**Range:** 0 to 65,535 mV

**Granularity:** 1 mV

**Accuracy:** Not applicable

**Invalid Data Indication:** 65,535 indicates the charger should operate as a current source outside its maximum regulated voltage range.

### BatteryStatus() (0x16)

**Description:** Returns the bq2084-V140 status word (flags). Some of the *BatteryStatus()* flags ( and *REMAINING\_TIME\_ALARM*) are calculated on the basis of either current or power depending on the setting of the *BatteryMode()**CAPACITY\_MODE* bit. This is important because use of the wrong calculation mode may result in an inaccurate alarm.

**Purpose:** The *BatteryStatus()* function is used by the power management system to get alarm and status bits, as well as error codes from the bq2084-V140. This is basically the same information broadcast to both the SMBus host and the smart battery charger by the *AlarmWarning()* function except that the *AlarmWarning()* function sets the error code bits all high before sending the data.

**SMBus protocol:** Read word

**Output:** Unsigned Integer-status register with alarm conditions bit-mapped as follows:

ALARM BITS	
0x8000	OVER_CHARGED_ALARM
0x4000	TERMINATE_CHARGE_ALARM
0x2000	Reserved
0x1000	OVER_TEMP_ALARM
0x0800	TERMINATE_DISCHARGE_ALARM
0x0400	Reserved
0x0200	REMAINING_CAPACITY_ALARM
0x0100	REMAINING_TIME_ALARM
STATUS BITS	
0x0080	Initialized
0x0040	DISCHARGING
0x0020	FULLY_CHARGED
0x0010	FULLY_DISCHARGED
ERROR CODES	
0x0007	Unknown Error
0x0006	BadSize
0x0005	Overflow/Underflow
0x0004	AccessDenied
0x0003	UnsupportedCommand
0x0002	ReservedCommand
0x0001	Busy
0x0000	OK

### ALARM BITS

*OVER\_CHARGED\_ALARM* bit is set whenever the bq2084-V140 detects that the battery is being charged beyond the maximum overcharge limit, which is full capacity plus *Maximum Overcharge* DF 0x51-0x52. This bit is cleared when the bq2084-V140 detects that the battery is no longer being charged and there are 2 mAh of continuous discharge (i.e., the bq2084-V140 detects discharge activity or no activity above the digital filter).

**TERMINATE\_CHARGE\_ALARM** bit is set when the bq2084-V140 detects a primary charge termination. This bit is cleared when the bq2084-V140 detects that the battery is no longer being charged.

**OVER\_TEMP\_ALARM** bit is set when the bq2084-V140 detects that the internal battery temperature is greater than or equal to the *OverTemperature Charge* threshold while charging or *OverTemperature Discharge* threshold while discharging. This bit is cleared when the internal temperature falls back below the *OverTemperature Charge Reset* or *OverTemperature Discharge Reset* as appropriate.

**TERMINATE\_DISCHARGE\_ALARM** bit is set when  $RM = 0$ ,  $Voltage() = \text{Terminate Voltage DF } 0x67\text{-}0x68$ , the battery temperature is less than or equal to the *Charge Suspend Temp Low DF 0x79* or the CVUV bit in pack status is set indicating that a Li-ion cell voltage has dropped below the limit programmed in *Cell Under*. The bit is cleared when  $Voltage() > \text{Terminate Voltage}$ ,  $RM() > 0$ , and the CVUV bit is cleared.

**REMAINING\_CAPACITY\_ALARM** bit is set when the bq2084-V140 detects that *RemainingCapacity()* is less than that set by the *RemainingCapacityAlarm()* function. This bit is cleared when either the value set by the *RemainingCapacityAlarm()* function is lower than the *RemainingCapacity()* or when the *RemainingCapacity()* is increased by charging.

**REMAINING\_TIME\_ALARM** bit is set when the bq2084-V140 detects that the estimated remaining time at the present discharge rate is less than that set by the *RemainingTimeAlarm()* function. This bit is cleared when either the value set by the *RemainingTimeAlarm()* function is lower than the *AverageTimeToEmpty()* or when the *AverageTimeToEmpty()* is increased by charging.

## STATUS BITS

The initialized bit is set when the bq2084-V140 has detected a valid load of data flash at full or partial reset. It is cleared when the bq2084-V140 detects an improper data flash load.

**DISCHARGING** bit is set when the bq2084-V140 determines that the battery is not being charged. This bit is cleared when the bq2084-V140 detects that the battery is being charged.

**FULLY\_CHARGED** bit is set when the bq2084-V140 detects a primary charge termination or an Overcharge condition. It is cleared when *RelativeStateOfCharge()* is less than the programmed *Fully Charged Clear %* in DF 0x4a.

**FULLY\_DISCHARGED** bit is set when *Voltage()* or *VCELL* is less than the EDV2 threshold and *Current() < Overload Current* or when *RelativeStateOfCharge() < Battery Low %*. This bit is cleared when *RelativeStateOfCharge()* is greater than or equal to 20%.

## ERROR CODES

ERROR CODES	DESCRIPTION
OK	The bq2084-V140 processed the function code without detecting any errors.
Busy	The bq2084-V140 is unable to process the function code at this time.
Reserved	The bq2084-V140 detected an attempt to read or write to a function code reserved by this version of the specification. The bq2084-V140 detected an attempt to access an unsupported optional manufacturer function code.
Unsupported	The bq2084-V140 does not support this function code which is defined in this version of the specification.
AccessDenied	The bq2084-V140 detected an attempt to write to a read-only function code.
Overflow/Underflow	The bq2084-V140 detected a data overflow or underflow.
BadSize	The bq2084-V140 detected an attempt to write to a function code with an incorrect data block.
UnknownError	The bq2084-V140 detected an unidentifiable error.

## CycleCount()(0x17)

**Description:** Returns the number of cycles the battery has experienced. The mAh value of each count is determined by programming the *Cycle Count Threshold* value in DF 0x38-0x39. The bq2084-V140 saves the cycle count value to *Cycle Count DF 0x0c-0x0d* after an update to *CycleCount()*.

**Purpose:** The *CycleCount()* function provides a means to determine the battery wear. It may be used to give advance warning that the battery is nearing its end of life.

**SMBus protocol:** Read word

**Output:** Unsigned integer—count of total charge removed from the battery over its life.

**Units:** cycle

**Range:** 0 to 65,534 cycles; 65,535 indicates battery has experienced 65,535 or more cycles.

**Granularity:** 1 cycle

**Accuracy:** Absolute count

### DesignCapacity() (0x18)

**Description:** Returns the theoretical or nominal capacity of a new pack. The *DesignCapacity()* value is expressed in either current (mAh at a C/5 discharge rate) or power, (10 mWh at a P/5 discharge rate) depending on the setting of the *BatteryMode()*CAPACITY\_MODE bit.

**Purpose:** The *DesignCapacity()* function is used by the SMBus host's power management along with *FullChargeCapacity()* to determine battery wear. The power management system may present this information to the user and also adjust its power policy as a result.

**SMBus protocol:** Read word

**Output:** Unsigned integer—battery capacity in units of mAh or 10 mWh.

	BATTERY MODES	
	CAPACITY_MODE BIT = 0	CAPACITY_MODE BIT = 1
Units	mAh	10 mWh
Range	0-65,535 mAh	0-65,535 10 mWh
Granularity	Not applicable	Not applicable
Accuracy	Not applicable	Not applicable

### DesignVoltage() (0x19)

**Description:** Returns the theoretical voltage of a new pack (mV). The bq2084-V140 sets *DesignVoltage()* to the value programmed in *Design Voltage DF 0x04-0x05*.

**Purpose:** The *DesignVoltage()* function can be used to give additional information about a particular smart battery expected terminal voltage.

**SMBus protocol:** Read word

**Output:** Unsigned integer—the battery's designed terminal voltage in mV

**Units:** mV

**Range:** 0 to 65,535 mV

**Granularity:** Not applicable

**Accuracy:** Not applicable

### SpecificationInfo() (0x1a)

**Description:** Returns the version number of the smart battery specification the battery pack supports, as well as voltage and current scaling information in a packed unsigned integer. Power scaling is the product of the voltage scaling times the current scaling. The *SpecificationInfo()* is packed in the following fashion:

$$(\text{SpecID\_H} \times 0x10 + \text{SpecID\_L}) + (\text{VScale} + \text{IPScale} \times 0x10) \times 0x100.$$

The bq2084-V140 *VScale* (voltage scaling) and *IPScale* (current scaling) should always be set to zero. The bq2084-V140 sets *SpecificationInfo()* to the value programmed in *Specification Information DF 0x06-0x07*.

**Purpose:** The *SpecificationInfo()* function is used by the SMBus host's power management system to determine what information the smart battery can provide.

**SMBus protocol:** Read word

**Output:** Unsigned integer—packed specification number and scaling information:

FIELD	BITS USED	FORMAT	ALLOWABLE VALUES
SpecID_L	0...3	4-bit binary value	0–15
SpecID_H	4...7	4-bit binary value	0–15
VScale	8...11	4-bit binary value	0 (multiplies voltage by 10 <sup>^</sup> VScale)
IPScale	12...15	4-bit binary value	0 (multiplies current by 10 <sup>^</sup> IPScale)

### ManufactureDate() (0x1b)

**Description:** This function returns the date the cell pack was manufactured in a packed integer. The date is packed in the following fashion: (year-1980) \* 512 + month \* 32 + day. The bq2084-V140 sets *ManufactureDate()* to the value programmed in *Manufacture Date* DF 0x08-0x09.

**Purpose:** The *ManufactureDate()* provides the system with information that can be used to uniquely identify a particular battery pack when used along with *SerialNumber()*.

**SMBus protocol:** Read word

**Output:** Unsigned integer-packed date of manufacture:

FIELD	BITS USED	FORMAT	ALLOWABLE VALUES
Day	0...4	5-bit binary value	0-31 (corresponds to date)
Month	5...8	4-bit binary value	1-12 (corresponds to month number)
Year	9...15	7-bit binary value	0-127 (corresponds to year biased by 1980)

### SerialNumber() (0x1c)

**Description:** This function is used to return a serial number. This number, when combined with the *ManufacturerName()*, the *DeviceName()*, and the *ManufactureDate()*, uniquely identifies the battery (unsigned integer). The bq2084-V140 sets *SerialNumber()* to the value programmed in *Serial Number* DF 0x0a-0x0b.

**Purpose:** The *SerialNumber()* function can be used to identify a particular battery. This may be important in systems that are powered by multiple batteries where the system can log information about each battery that it encounters.

**SMBus protocol:** Read word

**Output:** Unsigned integer

### ManufacturerName() (0x20)

**Description:** This function returns a character array containing the battery manufacturer's name. For example, MyBattCo identifies the smart battery manufacturer as MyBattCo. The bq2084-V140 sets *ManufacturerName()* to the value programmed in *Manufacturer Name* DF 0x0e-0x19. When *Misc Configuration 2* SSTRING is set then the extended manufacturer name data flash is appended (0x151-0x15f).

**Purpose:** The *ManufacturerName()* function returns the name of the smart battery manufacturer. The manufacturer's name can be displayed by the SMBus host's power management system display as both an identifier and as an advertisement for the manufacturer. The name is also useful as part of the information required to uniquely identify a battery.

**SMBus protocol:** Read block

**Output:** String—character string with maximum length of 11 characters (11 + length byte).

### DeviceName() (0x21)

**Description:** This function returns a character string that contains the battery name. For example, a *DeviceName()* of bq2084-V140 indicates that the battery is a model bq2084-V140. The bq2084-V140 sets *DeviceName()* to the value programmed in *Device Name* DF 0x1a-0x21. When *Misc Configuration 2* SSTRING is set then the extended device name data flash is appended (0x141-0x14f).

**Purpose:** The *DeviceName()* function returns the battery name for identification purposes.

**SMBus protocol:** Read block

**Output:** String—character string with maximum length of 7 characters (7 + length byte).

### DeviceChemistry() (0x22)

**Description:** This function returns a character string that contains the battery chemistry. For example, if the *DeviceChemistry()* function returns *NiMH*, the battery pack contains nickel metal hydride cells. The bq2084-V140 sets *DeviceChemistry()* to the value programmed in *Device Chemistry DF 0x22-0x26*.

**Purpose:** The *DeviceChemistry()* function gives cell chemistry information for use by charging systems. The bq2084-V140 does not use *DeviceChemistry()* values for internal charge control or fuel gauging.

**SMBus protocol:** Read block

**Output:** String—character string with maximum length of 4 characters (4 + length byte).

The following is a partial list of chemistries and their expected abbreviations. These abbreviations are *not* case sensitive.

CHEMISTRY	ABBREVIATIONS
Lead acid	PbAc
Lithium ion	LION
Nickel cadmium	NiCd
Nickel metal hydride	NiMH
Nickel zinc	NiZn
Rechargeable alkaline-manganese	RAM
Zinc air	ZnAr

### The ManufacturerData() (0x23)

**Description:** This function allows access to the manufacturer data contained in the battery (data). The bq2084-V140 stores seven critical operating parameters in this data area.

**Purpose:** The *ManufacturerData()* function may be used to access the manufacturer's data area. The data fields of this command reflect the programming of eight critical data flash locations and can be used to facilitate evaluation of the bq2084-V140 under various programming sets. The *ManufacturerData()* function returns the following information in order: *Pack Configuration, Gauge Configuration, Misc Configuration (2 bytes), Digital Filter, Self Discharge Rate, Pack Load Estimate, Battery Low%, and Near Full (2 bytes) AFE Status*, and the pending EDV threshold voltage (low byte and high byte).

**SMBus protocol:** Read block

**Output:** Block data—data that reflects data flash programming as assigned by the manufacturer with maximum length of 13 characters (13 + length byte).

### Pack Status and Pack Configuration (0x2f)

This function returns the pack status and pack configuration registers. The pack status register contains a number of status bits relating to bq2084-V140 operation. The pack status register is the least significant byte of the word. The pack configuration register reflects how the bq2084-V140 is configured as defined by the value programmed in *Pack Configuration* in DF 0x28.

The pack status register consists of the following bits:

b7	b6	b5	b4	b3	b2	b1	b0
PRES	EDV2	SS	VDQ	AFEFAIL	PF	CVOV	CVUV

#### PRES

The PRES bit indicates that the bq2084-V140 has been inserted into the system.

- 0 bq2084-V140 is out of the system
- 1 bq2084-V140 is inserted into a system

**EDV2**

The EDV2 bit indicates that pack or cell voltage (program option) is less than the EDV2 threshold.

- 0 Voltage > EDV2 threshold (discharging)
- 1 Voltage = EDV2 threshold

**SS**

The SS bit indicates the seal state of the bq2084-V140.

- 0 The bq2084-V140 is in the unsealed state.
- 1 The bq2084-V140 is in the sealed state.

**AFEFAIL**

The AFEFAIL bit indicates that AFE communications has failed.

- 0 AFE communications are okay.
- 1 AFE communications have failed.

**VDQ**

The VDQ bit indicates if the present discharge cycle is valid for an FCC update.

- 0 Discharge cycle not valid
- 1 Discharge cycle valid

**PF**

The PF bit indicates that the bq2084-V140 *PF Flag* has been set. It is cleared only when the *PF Flag* has been cleared.

- 0 bq2084-V140 *PF Flag* = 0x00
- 1 bq2084-V140 *PF Flag* = 0x66

**CVOV**

The CVOV bit indicates that a protection limit has been exceeded including Prolonged Overcurrent, Overvoltage, or Overtemperature conditions. The bit is not latched and merely reflects the present fault status.

- 0 No secondary protection limits exceeded
- 1 A secondary protection limit exceeded

**CVUV**

The CVUV bit indicates that a protection limit has been exceeded including overload or overdischarge conditions. The bit is not latched and merely reflects the present fault status.

- 0 No secondary protection limits exceeded
- 1 A secondary protection limit exceeded

**VCELL4-VCELL1 (0x3c-0x3f)**

These functions return the calculated individual cell voltages in mV. If NVCELL is set in *Misc Configuration 2* then the SMBus commands are changed to 0x38-0x3b). The alternative commands are NACK'ed when not selected.

**DATA FLASH****General**

The bq2084-V140 accesses the internal data flash during reset and when storing historical data. The data flash stores basic configuration information for use by the bq2084-V140. The data flash must be programmed correctly for proper bq2084-V140 operation.

## Memory Map

The following table shows the memory map for the data flash. It shows the default programming for the bq2084-V140. The default programming reflects example data for a 3s2p Li-ion battery pack with a 0.02-Ω sense resistor. The data flash must be reprogrammed to meet the requirements of individual applications.

DATA FLASH ADDRESS		NAME	LI-ION EXAMPLE	DATA	
HIGH BYTE	LOW BYTE			MSB	LSB
0x00	0x01	<i>Remaining Time Alarm</i>	10 minutes	00	0a
0x02	0x03	<i>Remaining Capacity Alarm</i>	360 mAh	01	68
0x04	0x05	<i>Design Voltage</i>	14400 mV	38	40
0x06	0x07	<i>Specification Information</i>	v1.1/PEC	00	31
0x08	0x09	<i>Manufacture Date</i>	1/1/2003=11809	2e	21
0x0a	0x0b	<i>Serial Number</i>	1	00	01
0x0c	0x0d	<i>Cycle Count</i>	0	00	00
0x0e		<i>Manufacturer Name Length</i>	11		0b
0x0f		Character 1	T		54
0x10		Character 2	e		45
0x11		Character 3	x		58
0x12		Character 4	a		41
0x13		Character 5	s		53
0x14		Character 6			20
0x15		Character 7	l		49
0x16		Character 8	n		4e
0x17		Character 9	s		53
0x18		Character 10	t		54
0x19		Character 11	.		2e
0x1a		<i>Device Name Length</i>	6		06
0x1b		Character 1	b		42
0x1c		Character 2	q		51
0x1d		Character 3	2		32
0x1e		Character 4	0		30
0x1f		Character 5	8		38
0x20		Character 6	4		34
0x21		Character 7	—		00
0x22		<i>Device Chemistry Length</i>	4		04
0x23		Character 1	L		4c
0x24		Character 2	l		49
0x25		Character 3	O		4f
0x26		Character 4	N		4e
0x27		<i>Manufacturer Data Length</i>	9		09
0x28		<i>Pack Configuration</i>	DMODE, 4-LEDs, 4-CELL		c3
0x29		<i>Gauge Configuration</i>	CSYNC, OTVC		41
0x2a	0x2b	<i>Misc Configuration</i>	OT, VOD	0b	00
0x2c		<i>Digital Filter (Dead Band)</i>	9860 nV		22
0x2d		<i>Self-Discharge Rate</i>	0.2%		14
0x2e		<i>Electronics Load</i>	0 mA		00
0x2f		<i>Battery Low % (MSB)</i>	7.03%		12
0x30	0x31	<i>Near Full</i>	200 mAh	00	c8
0x32	0x33	<i>Design Capacity</i>	7200 mAh	1c	20
0x34	0x35	Reserved	0	00	00

DATA FLASH ADDRESS		NAME	LI-ION EXAMPLE	DATA	
HIGH BYTE	LOW BYTE			MSB	LSB
0x36	0x37	Full Charge Capacity	7200 mAh	1c	20
0x38	0x39	Cycle Count Threshold	5200 mAh	14	50
0x3a	0x3b	Charging Voltage	16800 mV	41	a0
0x3c	0x3d	Precharge Voltage	2500 mV	09	c4
0x3e	0x3f	Fast-Charging Current	2500 mA	09	c4
0x40	0x41	Maintenance Charging Current	0 mA	00	00
0x42	0x43	Precharge Current	100 mA	00	64
0x44		Precharge Temperature	9.6°C		60
0x45		Precharge Temperature Hysteresis	3.0°C		1e
0x46		Charge Inhibit Temp Low	0.0°C		00
0x47	0x48	Charge Inhibit Temp High	50°C	01	f4
0x49		Fast Charge Termination %	100%		ff
0x4a		Fully Charged Clear %	95%		5f
0x4b	0x4c	Current Taper Threshold	240 mA	00	f0
0x4d	0x4e	Current Taper Qual Voltage	300 mV	01	2c
0x4f		Current Taper Window	40s		28
0x50		Reserved			40
0x51	0x52	Maximum Overcharge	300 mAh	01	2c
0x53		Reserved			02
0x54		Charge Efficiency	100%		ff
0x55		Reserved			64
0x56	0x57	Reserved		02	22
0x58		Reserved			32
0x59	0x5a	Reserved		01	ae
0x5b	0x5c	Overload Current	5000 mA	13	88
0x5d	0x5e	Over Voltage Margin	700 mV	02	bc
0x5f	0x60	Reserved		01	f4
0x61	0x62	Clear Fail Current	256 mA	01	00
0x63	0x64	Cell Over Voltage	4350 mV	10	fe
0x65	0x66	Cell Under Voltage	2300 mV	08	fc
0x67	0x68	Terminate Voltage	11300 mV	2c	24
0x69	0x6a	Reserved		00	00
0x6b	0x6c	Safety Over Voltage	20000 mV	3a	98
0x6d	0x6e	Charge Suspend Temp High	60°C	02	58
0x6f	0x70	Charge Suspend Temp High Reset	55°C	02	26
0x71	0x72	Over Temperature Discharge	70°C	02	bc
0x73	0x74	Over Temperature Discharge Reset	60°C	02	58
0x75	0x76	Safety OverTemperature Charge	75°C	02	ee
0x77	0x78	Safety OverTemperature Discharge	75°C	02	ee
0x79		Charge Suspend Temp Low	0°C		00
0x7a		Reserved			ef
0x7b		Current Deadband	3 mA		03
0x7c	0x7d	Shutdown Voltage	8800 mV	22	60
0x7e	0x7f	VOC75	15848 mV	3d	e8
0x80		Reserved			bf
0x81		Reserved			56
0x82		Reserved			40



DATA FLASH ADDRESS		NAME	LI-ION EXAMPLE	DATA	
HIGH BYTE	LOW BYTE			MSB	LSB
0x83	0x84	VOC50	15240 mV	3b	88
0x85		Reserved			7f
0x86		Reserved			3d
0x87		Reserved			27
0x88	0x89	VOC25	15024 mV	3a	b0
0x8a		Reserved			3f
0x8b		Reserved			24
0x8c		Reserved			0e
0x8d		Reserved			14
0x8e		<i>Voltage Average Time</i>	1 s		01
0x8f		<i>Correction Current Limit</i>	64 mA		40
0x90	0x91	Reserved		0b	e1
0x92	0x93	Reserved		0b	68
0x94		Reserved			19
0x95	0x96	<i>EMF/EDV0</i>	3000 mV	0b	b8
0x97	0x98	<i>EDV C0 Factor/EDV1</i>	3250 mV	0c	b2
0x99	0x9a	<i>EDV R0 Factor/EDV2</i>	3400 mV	0d	48
0x9b	0x9c	<i>EDV T0 Factor</i>	0	00	00
0x9d	0x9e	<i>EDV R1 Factor</i>	0	00	00
0x9f		<i>EDV TC Factor</i>	0		00
0xa0		<i>EDV C1 Factor</i>	0		00
0xa1		Reserved			08
0xa2		Reserved			9b
0xa3		Reserved			c7
0xa4		Reserved			64
0xa5		Reserved			14
0xa6	0xa7	Reserved		02	00
0xa8	0xa9	Reserved		01	00
0xaa		Reserved			08
0xab		Reserved			02
0xac		<i>Learning Low Temp</i>	11.9°C		77
0xad		Reserved			0a
0xae	0xaf	Reserved		01	80
0xb0	0xb1	Reserved		01	00
0xb2		Reserved			08
0xb3		Reserved			18
0xb4		Reserved			14
0xb5	0xb6	TS Const 1		91	83
0xb7	0xb8	TS Const 2		51	70
0xb9	0xba	TS Const 3		e2	8f
0xbb	0xbc	TS Const 4		0f	ac
0xbd	0xbe	TS Const 5		00	00
0xbf	0xc0	Reserved		0f	ac
0xc1		Reserved			02
0xc2		<i>AFE State Control</i>			00
0xc3		<i>AFE Function Control</i>			00
0xc4		<i>AFE Cell Select</i>			00

DATA FLASH ADDRESS		NAME	LI-ION EXAMPLE	DATA	
HIGH BYTE	LOW BYTE			MSB	LSB
0xc5		AFE Overload	140 mV		12
0xc6		AFE Overload Delay	31 ms		0f
0xc7		AFE Short Circuit Charge			17
0xc8		AFE Short Circuit Discharge			17
0xc9	0xca	AFE Vref* (1)	9750 mV	26	16
0xcb	0xcc	Sense Resistor Gain* (1)	0.02 &	3b	d0
0xcd	0xce	CC Delta* (1)	0.0000323 mAh	92	0a
0xcf	0xd0	CC Delta* (1)		16	00
0xd1		Reserved			fa
0xd2	0xd3	CC Offset* (2)	49701	c2	25
0xd4		DSC Offset* (2)	38		26
0xd5		ADC Offset* (2)	38		26
0xd6		Temperature Offset* (1)	0		00
0xd7		Board Offset* (1)	0		00
0xd8	0xd9	Reserved		00	40
0xda	0xdb	Reserved		01	00
0xdc		Reserved			05
0xdd	0xde	Version	1.0	01	00
0xdf		Reserved		00	32
0xe0	0xe1	Cell Over Voltage Reset	4150 mV	10	36
0xe2	0xe3	Cell Under Voltage Reset	3000 mV	0b	b8
0xe4	0xe5	AFE Fail Limit	2 counts	00	02
0xe6	0xe7	Reserved		ff	ff
0xe8	0xe9	Cell Balance Thresh	3900 mV	0f	3c
0xea	0xeb	Cell Balance Window	100 mV	00	64
0xec		Cell Balance Min	40 mV		28
0xed		Cell Balance Interval	20 s		14
0xee	0xef	Cell Imbalance Threshold		01	f4
0xf0	0xf1	Balance Vcell Max		10	36
0xf2	0xf3	Balance I <sub>max</sub>		00	9e
0xf4	0xf5	Reserved		a5	5a
0xf6	0xf7	Reserved		7a	43
0xf8	0xf9	Reserved		20	83
0xfa		Battery Low (LSB)	7.03 %		12
0xfb		AFE Check Time	0 s		00
0xfc		Sleep Current Thresh	2 mA		04
0xfd		Sleep Current Multiplier	5 counts		05
0xfe		Sleep Time	20 s		14
0xff	0x100	Manufacturer Info 1		00	00
0x101	0x102	Manufacturer Info 2		00	00
0x103	0x104	Manufacturer Info 3		00	00
0x105	0x106	V <sub>max</sub> Charge Voltage	4280 mv	10	b8
0x107	0x108	V <sub>off</sub> Charge Voltage	4280 mv	10	b8
0x109	0x10a	V <sub>on</sub> Charge Voltage	4200 mv	10	68

- (1) Reserved locations must be set as shown. Locations marked with an \* are typical calibration values that can be adjusted for maximum accuracy. For these locations, the table shows the appropriate default or initial setting.
- (2) Reserved locations must be set as shown. Locations marked with an \* are typical calibration values that can be adjusted for maximum accuracy. For these locations, the table shows the appropriate default or initial setting.

DATA FLASH ADDRESS		NAME	LI-ION EXAMPLE	DATA	
HIGH BYTE	LOW BYTE			MSB	LSB
0x10b	0x10c	<i>Pulse Max On Time</i>	60 s	01	e0
0x10d	0x10e	<i>Pulse Min Off Time</i>	0.125 s	00	01
0x10f	0x110	<i>Max Charge Time</i>	7200 s	1c	20
0x111	0x112	<i>Precharge Detection Current</i>	10 mA	00	0a
0x113	0x114	<i>Charge Detection Current</i>	100 mA	00	64
0x115	0x116	<i>Discharge Detection Current</i>	-150 mA	ff	6a
0x117	0x118	Reserved		10	68
0x119	0x11a	Reserved		10	36
0x11b	0x11c	Reserved			00
0x11d		<i>Permanent Fail Status</i>	0		00
0x11e		<i>Permanent Fail Flag</i>	0		00
0x11f		<i>Permanent Fail Config</i>	0		00
0x120		<i>Permanent Fail Input Time</i>	0		00
0x121	0x122	Reserved		17	12
0x123	0x124	Reserved		26	73
0x125	0x126	<i>FET Fail Charge Current</i>	20 mA	00	20
0x127	0x128	<i>FET Fail Discharge Current</i>	-20 mA	ff	ec
0x129		<i>FET Fail Time</i>	20 s		14
0x12a	0x12b	<i>Charge OC Threshold</i>	4000 mA	0f	a0
0x12c		<i>Charge OC Time</i>	6 s		06
0x12d	0x12e	<i>Discharge OC Threshold</i>	10970 mA	2a	da
0x12f		<i>Discharge OC Time</i>	10 s		00
0x130		<i>Fault Reset Time</i>	30 s		1e
0x131	0x132	<i>VPACK Threshold</i>		07	d0
0x133		<i>Shutdown Timer</i>	20 s		14
0x134		<i>Cell Imbalance Time</i>	20 s		14
0x135	0x136	Reserved			
0x137	0x138	EDV0	3000mV	0b	b8
0x139		<i>Misc Configuration 2</i>			00
0x13a	13b	Reserved		ff	ff
0x13c	13d	Reserved		ff	ff
0x13e	13f	Reserved		ff	ff
0x140		<i>Aux Device Name Length</i>	0 bytes		00
0x141	0x14f	<i>Aux Device Name</i>		00	00
0x150		<i>Aux Manufacturer Name Length</i>	0 bytes		00
0x151	0x15f	<i>Aux Manufacturer Name</i>		00	00
0x160		<i>AFE Recovery</i>	3s		03
0x161		<i>AFE Holdoff</i>	30s		1e
0x162		<i>Over Temperature Time</i>	10s		0a
0x163	0x164	Reserved		00	0a
0x165		Reserved			0a

## ADDITIONAL PROGRAMMING INFORMATION

### ADDITIONAL DATA FLASH PROGRAMMING

The following sections describe the function of each data flash location and how the data is to be stored.

#### Fundamental Parameters

##### Sense Resistor Value

The 32-bit *CC Delta* DF 0xcd-0xd0 corrects the coulomb counter for sense resistor variations. It represents the gain factor for the coulomb counter. The 16-bit *Sense Resistor Gain* in DF 0xcb-0xcc scales each integrating converter conversion to mAh. The Current() related measurement *Sense Resistor Gain* is based on the resistance of the series sense resistor. The following formula computes a nominal or starting value for *Sense Resistor Gain* from the sense resistor value (in  $\Omega$ ).

$$\text{Sense Resistor Gain} = 306.25/R_s$$

RSNS Value ( $m\Omega$ )	Sense Resistor Gain
5	61250
10	30625
20	15312

##### CC offset

*CC offset* DF 0xd2-0xd3, contains the offset for the coulomb counter. It is automatically updated when the pack has met the conditions for sleep, before it enters sleep mode.

##### DSC offset

*DSC offset* DF 0xd4, contains the offset for the pack ground reference. It is automatically updated when the pack has met the conditions for sleep, before it enters sleep mode.

##### ADC offset

*ADC offset* DF 0xd5, contains the offset for the a/d converter. It is automatically updated when the pack has met the conditions for sleep, before it enters sleep mode.

##### Digital Filter

The desired digital filter threshold, VDF (V), is set by the value stored in *Digital Filter* DF 0x2c.

$$\text{Digital Filter} = \text{VDF} / 290 \text{ nV}$$

## CELL AND PACK CHARACTERISTICS

### Battery Pack Capacity and Voltage

Pack capacity in mAh units is stored in *Design Capacity*, DF 0x32-0x33. In mAh mode, the bq2084-V140 copies *Design Capacity* to DesignCapacity(). In mWh mode, the bq2084-V140 multiplies *Design Capacity* by *Design Voltage* DF 0x04-0x05 to calculate DesignCapacity() scaled to 10 mWh. *Design Voltage* is stored in mV.

The initial value for *Full Charge Capacity*, in mAh, is stored in DF 0x36-0x37. *Full Charge Capacity* is modified over the course of pack usage to reflect cell aging under the particular use conditions. The bq2084-V140 updates *Full Charge Capacity* in mAh after a capacity learning cycle.

### Remaining Time Alarm and Capacity Alarm

*Remaining Time Alarm* in DF 0x02-0x03 set the alarm thresholds used in the SMBus command codes 0x01 and 0x02, respectively. *Remaining Time Alarm* is stored in minutes and *Remaining Capacity Alarm* in units of mAh or 10 mWh, depending on the BatteryMode() setting.

### **Cycle Count Initialization**

*Cycle Count DF 0x0c-0x0d* stores the initial value for the `CycleCount()` function. It should be programmed to 0x0000.

### **Cycle Count Threshold**

*Cycle Count Threshold 0x37-0x38* sets the number of mAh that must be removed from the battery to increment `CycleCount()`. Cycle Count threshold is a 16-bit value stored in mAh.

### **Charge Efficiency**

The bq2084-V140 applies the efficiency factor, EFF%, to all charge added to the battery. EFF% is encoded in *Charge Efficiency DF 0x54* according to the following equation:

$$\text{Charge Efficiency} = (\text{EFF\% w } 2.56-1)$$

## **PACK OPTIONS**

### **Pack Configuration**

*Pack Configuration DF 0x28* contains bit-programmable features.

b7	b6	b5	b4	b3	b2	b1	b0
DMODE	LED1	LED0	HPE	CPE	SM	CC1	CC0

#### **DMODE**

The DMODE bit determines whether the LED outputs indicate `AbsoluteStateOfCharge()` or `RelativeStateOfCharge()`.

- 0 LEDs reflect `AbsoluteStateOfCharge()`
- 1 LEDs reflect `RelativeStateOfCharge()`

#### **LED1–LED0**

The LED bits set the number of LEDs for `RemainingCapacity()` indication.

- 0-0 Configures the bq2084-V140 for five LEDs
- 0-1 Configures the bq2084-V140 for three LEDs
- 1-0 Configures the bq2084-V140 for four LEDs
- 1-1 Configures the bq2084-V140 for five LEDs

#### **HPE**

The HPE bit enables/disables PEC transmissions to the smart battery host for master mode alarm messages.

- 0 No PEC byte on alarm warning to host
- 1 PEC byte on alarm warning to host

#### **CPE**

The CPE bit enables/disables PEC transmissions to the smart battery charger for master mode messages.

- 0 No PEC byte on broadcasts to charger
- 1 PEC byte on broadcasts to charger

#### **SM**

The SM bit enables/disables master mode broadcasts by the bq2084-V140.

- 0 Broadcasts to host and charger enabled
- 1 Broadcasts to host and charger disabled

If the SM bit is set, modifications to bits in `BatteryMode()` do not re-enable broadcasts.

**CC1–CC0**

The CC bits configure the bq2084-V140 for the number of series cells in the battery pack.

- 1-1 Configures the bq2084-V140 for four series cells
- 1-0 Configures the bq2084-V140 for three series cells
- 0-1 Configures the bq2084-V140 for two series cells

**Gauge Configuration**

*Gauge Configuration* DF 0x29 contains bit-programmable features:

b7	b6	b5	b4	b3	b2	b1	b0
FEDV0	CSYNC	SC	CEDV	EDVV	OVSEL	VCOR	OTVC

**FEDV0**

When this bit is set, the EDV0 voltage is fixed while the EDV1 and EDV2 are left as compensated values if CEDV is also set. When this bit is set, the compensated values of EDV1 and EDV2 are limited from going below EDV0.

- 0 EDV0 acted upon per CEDV bit setting
- 1 EDV0 fixed regardless of CEDV setting

**CSYNC**

In usual operation of the bq2084-V140, the CSYNC bit is set so that the coulomb counter is adjusted when a fast charge termination is detected. In some applications, especially those where an externally controlled charger is used, it may be desirable *not* to adjust the coulomb counter. In these cases the CSYNC bit should be cleared.

- 0 The bq2084-V140 does not alter RM at the time of a valid charge termination.
- 1 The bq2084-V140 updates RM with a programmed percentage of FCC at a valid charger termination.

**SC**

The SC bit enables learning cycle optimization for a Smart Charger or independent charge.

- 1 Learning cycle optimized for independent charger
- 0 Learning cycle optimized for Smart Charger

**CEDV**

The CEDV bit determines whether the bq2084-V140 implements automatic EDV compensation to calculate the EDV0, EDV1, and EDV2 thresholds base on rate, temperature, and capacity. If the bit is cleared, the bq2084-V140 uses the fixed values programmed in data flash for EDV0, EDV1, and EDV2. If the bit is set, the bq2084-V140 calculates EDV0, EDV1, and EDV2.

- 0 EDV compensation disabled
- 1 EDV compensation enabled

**EDVV**

The EDVV bit selects whether EDV termination is to be done with regard to Voltage () or the lowest single-cell voltage.

- 0 EDV conditions determined on the basis of the lowest single-cell voltage
- 1 EDV conditions determined on the basis of Voltage()

**OVSEL**

The OVSEL bit determines if Safety Over Voltage is based on Voltage () or highest cell voltages.

- 0 Safety overvoltage based on Voltage ()

- 1 Safety overvoltage based on highest cell voltage multiplied by the number of cells and then compared to the safety voltage.

**VCOR**

The VCOR bit enables the midrange voltage correction algorithm. When it is set, the bq2084-V140 compares the pack voltage to RM and may adjust RM according to the values programmed in VOC25, VOC50, and VOC75.

- 0 Continuous midrange corrections disabled
- 1 Continuous midrange corrections enabled

**OTVC**

The OTVC bit programs the bq2084-V140 to perform a midrange voltage one time after a device reset

- 0 One-time midrange correction disabled
- 1 One-time midrange correction enabled

**Miscellaneous Configuration**

*Misc Configuration* DF 0x2a (high) and 0x2b (low) contains additional bit programmable features.

Misc Configuration (high) DF 0x2a

b15	b14	b13	b12	b11	b10	b9	b8
IT	0	AFEDET	DS	OT	ELED	1	VOD

**IT**

The IT bit configures the bq2084-V140 to use its internal temperature sensor. The DF constants 0xb5-0xc0 need to match the required thermistor on internal temperature sensor. See the Data Flash Settings for Internal or External Temperature Sensor Table.

- 0 bq2084-V140 requires an external thermistor.
- 1 bq2084-V140 uses its internal temperature sensor.

**AFEDET**

The AFEDET bit programs the bq2084-V140 to look for errors with I<sup>2</sup>C communications and the AFE and enables the detection of the AFE permanent failure if bit 3 of PF Config 0x11f is set.

- 0 Does not verify AFE communications.
- 1 Does verify AFE communications.

**DS**

The DS bit programs the bq2084-V140 to enter sleep mode on SMBus inactivity.

- 0 bq2084-V140 enters sleep mode when the SMBus is low for 2 s.
- 1 bq2084-V140 does not enter sleep mode.

**OT**

The OT bit enables the bq2084-V140 to turn off the FETs when the bq2084-V140 detects an overtemperature condition.

- 1 bq2084-V140 turns the appropriate FET off under over temperature conditions
- 0 bq2084-V140 takes no FET action at all on over temperature conditions

**ELED**

The ELED bit programs the LED activity during charging (DSG bit = 0).

- 0 The LEDs are not enabled during charging.
- 1 The LEDs are enabled during charging.

**VOD**

The VOD bit enables a 1-s time delay in the setting of the CVOV and CVUV bits in PackStatus.

- 0 No delay
- 1 1-s delay

**Misc Configuration (low) DF 0x2b**

b7	b6	b5	b4	b3	b2	b1	b0
LEDRCA	PFET1	PFET0	NR	CHGFET	0	0	DSGOT

**LEDRCA**

The LEDRCA bit programs the LED to blink when there is a RemainingCapacityAlarm.

- 0 The LEDs blink when there is a RemainingCapacityAlarm.
- 1 The LEDs are off when there is a RemainingCapacityAlarm.

**PFET1, PFET0**

The PFETx bits define the precharge FET operation. See the bq29312 data sheet for more detail.

- 0,0 The bq29312 ZVCHG FET is turned on for precharge. Assumes charger has precharge function.
- 0,1 The charge FET is turned on for precharge. Assumes charger has precharge function.
- 1,0 The bq29312 OD FET is turned on for precharge. Assumes charger does not have precharge function.
- 1,1 Not defined, unpredictable operation

**NR**

The NR bit defines whether the bq2084-V140 is to be used with a nonremovable system battery. If set to indicate a nonremovable system battery there are additional clear conditions for a battery failure due to overcharge, overcurrent, and overload. The additional conditions besides battery removal (defined as the loss system present pin going high) are either detection of an opposite current of that caused the failure or when *AverageCurrent()* is less than *Clear Fail Current* DF 0x61, 0x62 for a time defined by Fault Reset Time DF 0x130. Also, for a nonremovable battery the charge FET is left on for discharge current failures and the discharge FET is left on for charge current failures.

- 0 Removable battery, battery fail conditions cleared by battery removal only.
- 1 Nonremovable system battery.

**CHGFET**

The CHGFET bit programs the charge FET to remain on even after a charge terminate condition.

- 0 The charge FET is turned off after a charge termination condition.
- 1 The charge FET is turned on after a charge termination condition.

**DSGOT**

When this bit is set, it allows the DSG FET to remain on after overtemperature in charge conditions

- 0 bq2084-V140 turns both FETs off during an overtemperature in charge
- 1 bq2084-V140 only turns off the CHG FET during overtemperature in charge

**Misc Configuration 2 (low byte) (0x139)**

b7	b6	b5	b4	b3	b2	b1	b0
0	0	SSTRING	NVCELL	CCDSG	SOCL	CVFC	DEPFET

**SSTRING**

When this bit is set, it enables an additional 15 characters of storage for both SBS.ManufacturerName( ) and SBS.DeviceName( ). (Storage is in separate area of data flash)

- 0 ManufacturerName( ) and DeviceName( ) strings are 11 and 7 characters respectively



- 1 ManufacturerName( ) and DeviceName( ) strings are 26 and 22 characters respectively

#### **NVCELL**

When this bit is set, it forces SBS.VCELL1..4( ) to be accessible via alternative commands.

- 0 SBS.VCELL1..4( ) available via 0x3c-0x3f  
1 SBS.VCELL1..4( ) available via 0x38-0x3b

#### **CCDSG**

When this bit is set, it forces SBS.ChargingCurrent( ) to be reported as 0 when SBS.BatteryStatus( ) DISCHARGING is also set.

- 0 SBS.ChargingCurrent( ) is not modified just because SBS.BatteryStatus( ) DISCHARGING is set.  
1 SBS.ChargingCurrent( ) is set to 0 when SBS.BatteryStatus( ) DISCHARGING is set.

#### **SOCL**

When this bit is set, it limits both RSOC and ASOC to 99% until a valid charge termination is detected.

- 0 RSOC and ASOC are not limited.  
1 RSOC and ASOC are limited to 99% until charge termination.

#### **CVFC**

When this bit is set, it causes SBS.ChargingVoltage( ) to be set to 0 when SBS.BatteryStatus( ) FC = 1.

- 0 SBS.ChargingVoltage( ) is not modified  
1 SBS.ChargingVoltage( ) is set to 0 when FC = 1

#### **DEPFET**

When this bit is set, it enables the CHG FET to be turned on when in depleted mode and when the lowest cell voltage reading is greater than the precharge voltage threshold

- 0 No FET action taken  
1 CHG FET turned on

### **Constants and String Data**

#### **Specification Information**

*Specification Information* DF 0x06-0x07 stores the default value for the *SpecificationInfo()* function. It is stored in data flash in the same format as the data returned by the *SpecificationInfo()*.

#### **Manufacture Date**

*Manufacture Date* DF 0x08-0x09 stores the default value for the *ManufactureDate()* function. It is stored in data flash in the same format as the data returned by the *ManufactureDate()*.

#### **Serial Number**

*Serial Number* DF 0x0a-0x0b stores the default value for the *SerialNumber()* function. It is stored in data flash in the same format as the data returned by the *SerialNumber()*.

#### **Manufacturer Name Data**

*Manufacturer Name Length* DF 0x0e stores the length of the desired string that is returned by the *ManufacturerName()* function. Locations DF 0x0f-0x19 store the characters for *ManufacturerName()* in ASCII code.

#### **Device Name Data**

*Device Name Length* DF 0x1a stores the length of the desired string that is returned by the *DeviceName()* function. Locations DF 0x1b-0x21 store the characters for *DeviceName()* in ASCII code.

## Device Chemistry Data

*Device Chemistry Length* DF 0x22 stores the length of the desired string that is returned by the *DeviceChemistry()* function. Locations DF 0x23-0x26 store the characters for *DeviceChemistry()* in ASCII code.

## Manufacturers Data Length

*Manufacturers Data Length* DF 0x27 stores the length of the desired number of bytes that is returned by the *ManufacturersData()* function. It should be set to 9.

## Temperature Limits

The limits described below are extensions to those limits detailed in the safety and charging sections of this data sheet.

### Charge Suspend Temp Low

*Charge Suspend Temp Low* DF 0x79 sets the lowest temperature, in degrees C/10, at which normal operation is allowed. If the temperature falls below this limit, the pack goes into a temporary failure state, the charge FET is turned off, and the MAC status is set to system present. It is cleared when the pack warms, or the pack is removed.

### Charge Inhibit Temp Low

*Charge Inhibit Temp Low* DF 0x46 inhibits charging by setting *ChargingCurrent()* and *ChargingVoltage()* to 0 and turn off the CHG FET. It is programmed in degrees C/10 and the range of -12.8°C to 12.7°C.

### Charge Inhibit Temp High

*Charge Inhibit Temp High* DF 0x47 - 0x48 inhibits charging by setting *ChargingCurrent()* and *ChargingVoltage()* to 0

### Charge Suspend Temp High

*Charge Suspend Temp High* DF 0x6d-0x6e sets the highest temperature, in degrees C/10, at which charging will be allowed to continue. If this temperature is exceeded during charging, the pack goes into a temporary failure state, and the MAC status is set to system present. It is cleared when the pack cools below *OverTemperature Charge Reset*, or ac adapter is removed, or the pack is removed. Charging can only resume when the temperature returns to within the charge start temperature limits.

### Charge Suspend Temp High Reset

*Charge Suspend Temp High Reset* DF 0x6f-0x70 sets the temperature, in degrees C/10, at which the pack recovers from Charge Suspend Temp High fault.

### Over Temperature Discharge

*Over Temperature Discharge* DF 0x71-0x72 sets the highest temperature, in degrees C/10, at which discharging will be allowed. If the pack exceeds this temperature, charge and discharge FETs are turned off, and MAC status is set to system present. The pack returns to normal operation when the temperature falls below *Over Temperature Discharge Reset*, or if the pack is removed.

### Over Temperature Discharge Reset

*Over Temperature Discharge Reset* DF 0x73-0x74 sets the temperature, in degrees C/10, at which the pack will recover from Over Temperature Discharge. Over temperature will also reset when the pack is removed from the system if not in the non-removable mode.

## Failure Detection Thresholds

### Safety OverTemperature Charge

*Safety OverTemperature Charge* DF 0x75-0x76 sets the temperature, in degrees C/10, above which, during charging, the pack enters permanent failure, if the *XSOTC* bit in *Permanent Failure Configuration* is set.

### **Safety OverTemperature Discharge**

*Safety OverTemperature Discharge* DF 0x77-0x78 sets the temperature, in degrees C/10, above which, during discharging, the pack enters permanent failure, if the *XSOTD* bit in *Permanent Failure Configuration* is set.

### **Charge Detection Current**

*Charge Detection Current* DF 0x113-0x114 sets the threshold in milliamperes for detecting charge current. This is a signed value and is positive. This threshold is used for detecting cross-conduction, and ensuring that charge termination is not improperly detected due to loss of charging current.

### **Discharge Detection Current**

*Discharge Detection Current* DF 0x115-0x116 sets the threshold in milliamperes for detecting discharge current. This is a signed value and is negative. This threshold is used for detecting cross-conduction and determining that the charge FET should be turned on during discharge to reduce IR losses.

### **FET Fail Charge Current**

*FET Fail Charge Current* DF 0x125-0x126 sets the threshold in milliamperes for detecting current in a charge FET which is turned off. This is a signed value and is positive.

### **FET Fail Discharge Current**

*FET Fail Discharge Current* DF 0x127-0x128 sets the threshold in milliamperes for detecting current in a discharge FET which is turned off. This is a signed value and is negative.

### **FET Fail Time**

*FET Fail Time* DF 0x129 sets the time in seconds that current must be detected in a FET which is turned off, in order to determine that the FET has failed.

### **Terminate Voltage**

*Terminate Voltage* DF 0x67-0x68, sets the threshold below which the *Terminate Discharge Alarm* bit is set. The alarm is cleared when the voltage rises above this threshold, if the *CVUV* bit in *Pack Status* is not set.

## **Offsets and Limits**

### **Temperature offset**

*Temperature offset* DF 0xd6, contains a signed offset for the pack's temperature measurements, in degrees C/10. It is set at board test during pack calibration.

### **Board offset**

*Board offset* DF 0xd7, contains a signed offset for the pack's coulomb counter measurements. If used, it is set at board design time.

### **Current Deadband**

*Current Deadband* DF 0x7b, sets the threshold in mA below which a current measurement is not detected.

### **Shutdown Voltage**

*Shutdown Voltage* DF 0x7c-0x7d sets the pack voltage below which the pack's electronics, including the bq2084-V140, is shut down to conserve power. All FETs are turned off by the AFE.

## APPLICATION INFORMATION

[Figure 7](#) shows a typical bq2084-V140-based battery pack application. The circuit consists of the bq29312 AFE IC, bq29400 second-level protection IC, LED, temperature measurement network, data flash connections, serial port, and the sense resistor. The data flash stores basic battery pack configuration information and measurement calibration values. The data flash must be programmed properly for bq2084-V140 operation.

APPLICATION INFORMATION (continued)

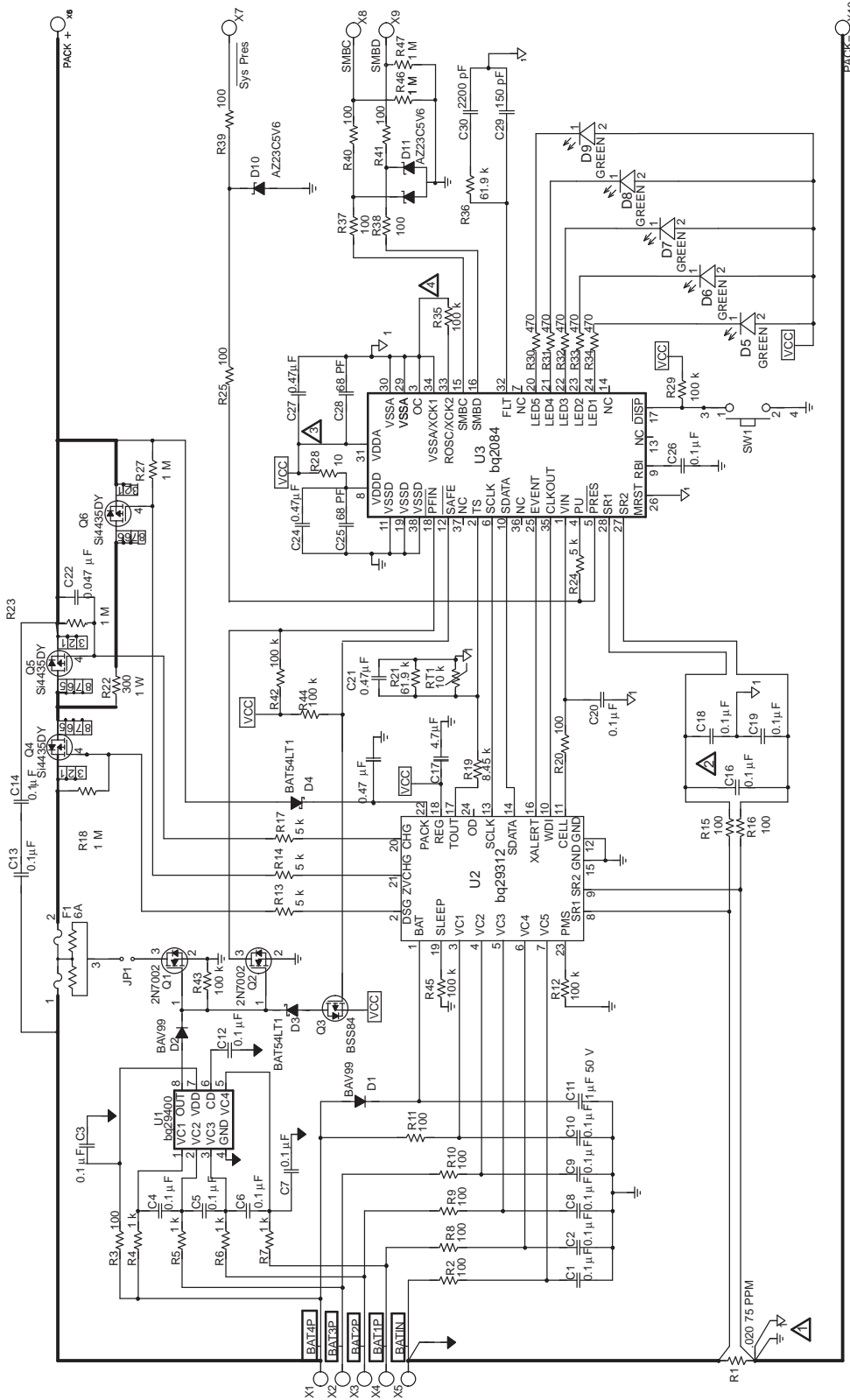

Figure 7. bq2084-V140 Based Battery Pack Schematic

- ▲ R35 is 0.2%, 75 ppm
- ▲ Place decoupling caps C24, C25, C27, C28 VERY close to U3 between pins 6, 11 and 3, 13 as shown. Insure that the 68pF cap is closest to the device.
- ▲ Place these 5 resistors in a symmetric pattern and route traces as a differential pair from the sense resistor to the SRT and SR2 inputs of the bq2084. R15 and R18 should connect to the sense resistor through trace NOT the ground plane. The length of the route and the actual path from the sense resistor to the SRT/SR2 inputs should be the same for both resistors to avoid ground voltage.
- ▲ Place the entire network of resistors and capacitors as close to U3 as possible.
- ▲ Connect Analog and Digital Ground at a single point as close to the ground nodes of the sense resistor, R1, as possible.

**PACKAGING INFORMATION**

Orderable Device	Status (1)	Package Type	Package Drawing	Pins	Package Qty	Eco Plan (2)	Lead/Ball Finish	MSL Peak Temp (3)	Samples (Requires Login)
BQ2084DBTR-V140	OBSOLETE	TSSOP	DBT	38		TBD	Call TI	Call TI	
BQ2084DBTR-V140G4	OBSOLETE	TSSOP	DBT	38		TBD	Call TI	Call TI	
BQ2084RTTR-V140	NRND	VQFN	RTT	36	3000	TBD	Call TI	Call TI	
BQ2084RTTR-V140G4	NRND	VQFN	RTT	36	3000	TBD	Call TI	Call TI	
BQ2084RTTT-V140	OBSOLETE	VQFN	RTT	36		TBD	Call TI	Call TI	
BQ2084RTTT-V140G4	OBSOLETE	VQFN	RTT	36		TBD	Call TI	Call TI	

(1) The marketing status values are defined as follows:

**ACTIVE:** Product device recommended for new designs.

**LIFEBUY:** TI has announced that the device will be discontinued, and a lifetime-buy period is in effect.

**NRND:** Not recommended for new designs. Device is in production to support existing customers, but TI does not recommend using this part in a new design.

**PREVIEW:** Device has been announced but is not in production. Samples may or may not be available.

**OBSOLETE:** TI has discontinued the production of the device.

(2) Eco Plan - The planned eco-friendly classification: Pb-Free (RoHS), Pb-Free (RoHS Exempt), or Green (RoHS & no Sb/Br) - please check <http://www.ti.com/productcontent> for the latest availability information and additional product content details.

**TBD:** The Pb-Free/Green conversion plan has not been defined.

**Pb-Free (RoHS):** TI's terms "Lead-Free" or "Pb-Free" mean semiconductor products that are compatible with the current RoHS requirements for all 6 substances, including the requirement that lead not exceed 0.1% by weight in homogeneous materials. Where designed to be soldered at high temperatures, TI Pb-Free products are suitable for use in specified lead-free processes.

**Pb-Free (RoHS Exempt):** This component has a RoHS exemption for either 1) lead-based flip-chip solder bumps used between the die and package, or 2) lead-based die adhesive used between the die and leadframe. The component is otherwise considered Pb-Free (RoHS compatible) as defined above.

**Green (RoHS & no Sb/Br):** TI defines "Green" to mean Pb-Free (RoHS compatible), and free of Bromine (Br) and Antimony (Sb) based flame retardants (Br or Sb do not exceed 0.1% by weight in homogeneous material)

(3) MSL, Peak Temp. -- The Moisture Sensitivity Level rating according to the JEDEC industry standard classifications, and peak solder temperature.

**Important Information and Disclaimer:** The information provided on this page represents TI's knowledge and belief as of the date that it is provided. TI bases its knowledge and belief on information provided by third parties, and makes no representation or warranty as to the accuracy of such information. Efforts are underway to better integrate information from third parties. TI has taken and continues to take reasonable steps to provide representative and accurate information but may not have conducted destructive testing or chemical analysis on incoming materials and chemicals. TI and TI suppliers consider certain information to be proprietary, and thus CAS numbers and other limited information may not be available for release.

In no event shall TI's liability arising out of such information exceed the total purchase price of the TI part(s) at issue in this document sold by TI to Customer on an annual basis.

MECHANICAL DATA

DBT (R-PDSO-G38)

PLASTIC SMALL OUTLINE

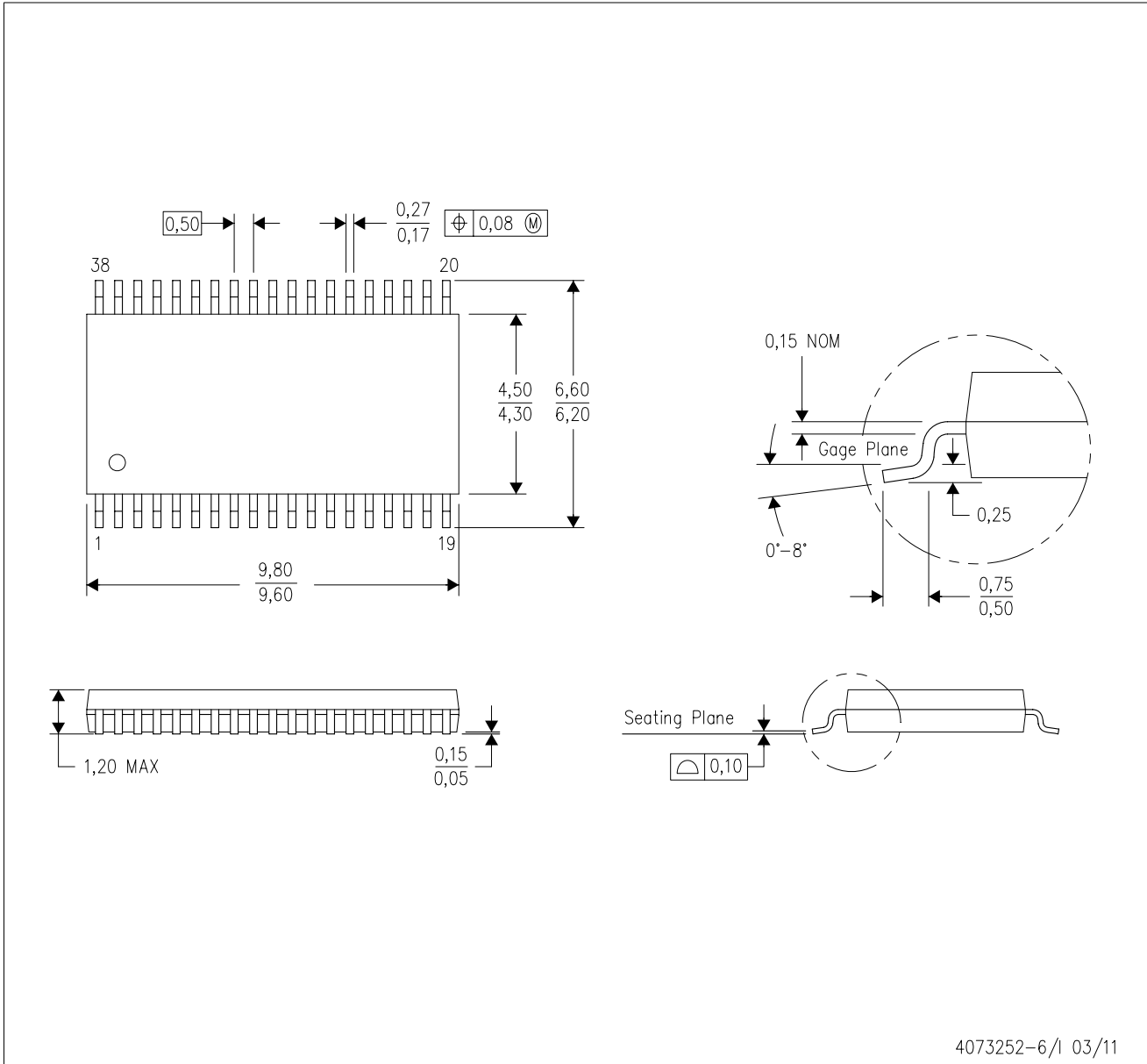

- NOTES:
- A. All linear dimensions are in millimeters. Dimensioning and tolerancing per ASME Y14.5M-1994.
  - B. This drawing is subject to change without notice.
  - C. Body dimensions do not include mold flash or protrusion.
  - D. Falls within JEDEC MO-153.

## IMPORTANT NOTICE

Texas Instruments Incorporated and its subsidiaries (TI) reserve the right to make corrections, enhancements, improvements and other changes to its semiconductor products and services per JESD46, latest issue, and to discontinue any product or service per JESD48, latest issue. Buyers should obtain the latest relevant information before placing orders and should verify that such information is current and complete. All semiconductor products (also referred to herein as "components") are sold subject to TI's terms and conditions of sale supplied at the time of order acknowledgment.

TI warrants performance of its components to the specifications applicable at the time of sale, in accordance with the warranty in TI's terms and conditions of sale of semiconductor products. Testing and other quality control techniques are used to the extent TI deems necessary to support this warranty. Except where mandated by applicable law, testing of all parameters of each component is not necessarily performed.

TI assumes no liability for applications assistance or the design of Buyers' products. Buyers are responsible for their products and applications using TI components. To minimize the risks associated with Buyers' products and applications, Buyers should provide adequate design and operating safeguards.

TI does not warrant or represent that any license, either express or implied, is granted under any patent right, copyright, mask work right, or other intellectual property right relating to any combination, machine, or process in which TI components or services are used. Information published by TI regarding third-party products or services does not constitute a license to use such products or services or a warranty or endorsement thereof. Use of such information may require a license from a third party under the patents or other intellectual property of the third party, or a license from TI under the patents or other intellectual property of TI.

Reproduction of significant portions of TI information in TI data books or data sheets is permissible only if reproduction is without alteration and is accompanied by all associated warranties, conditions, limitations, and notices. TI is not responsible or liable for such altered documentation. Information of third parties may be subject to additional restrictions.

Resale of TI components or services with statements different from or beyond the parameters stated by TI for that component or service voids all express and any implied warranties for the associated TI component or service and is an unfair and deceptive business practice. TI is not responsible or liable for any such statements.

Buyer acknowledges and agrees that it is solely responsible for compliance with all legal, regulatory and safety-related requirements concerning its products, and any use of TI components in its applications, notwithstanding any applications-related information or support that may be provided by TI. Buyer represents and agrees that it has all the necessary expertise to create and implement safeguards which anticipate dangerous consequences of failures, monitor failures and their consequences, lessen the likelihood of failures that might cause harm and take appropriate remedial actions. Buyer will fully indemnify TI and its representatives against any damages arising out of the use of any TI components in safety-critical applications.

In some cases, TI components may be promoted specifically to facilitate safety-related applications. With such components, TI's goal is to help enable customers to design and create their own end-product solutions that meet applicable functional safety standards and requirements. Nonetheless, such components are subject to these terms.

No TI components are authorized for use in FDA Class III (or similar life-critical medical equipment) unless authorized officers of the parties have executed a special agreement specifically governing such use.

Only those TI components which TI has specifically designated as military grade or "enhanced plastic" are designed and intended for use in military/aerospace applications or environments. Buyer acknowledges and agrees that any military or aerospace use of TI components which have **not** been so designated is solely at the Buyer's risk, and that Buyer is solely responsible for compliance with all legal and regulatory requirements in connection with such use.

TI has specifically designated certain components as meeting ISO/TS16949 requirements, mainly for automotive use. In any case of use of non-designated products, TI will not be responsible for any failure to meet ISO/TS16949.

### Products

Audio	<a href="http://www.ti.com/audio">www.ti.com/audio</a>
Amplifiers	<a href="http://amplifier.ti.com">amplifier.ti.com</a>
Data Converters	<a href="http://dataconverter.ti.com">dataconverter.ti.com</a>
DLP® Products	<a href="http://www.dlp.com">www.dlp.com</a>
DSP	<a href="http://dsp.ti.com">dsp.ti.com</a>
Clocks and Timers	<a href="http://www.ti.com/clocks">www.ti.com/clocks</a>
Interface	<a href="http://interface.ti.com">interface.ti.com</a>
Logic	<a href="http://logic.ti.com">logic.ti.com</a>
Power Mgmt	<a href="http://power.ti.com">power.ti.com</a>
Microcontrollers	<a href="http://microcontroller.ti.com">microcontroller.ti.com</a>
RFID	<a href="http://www.ti-rfid.com">www.ti-rfid.com</a>
OMAP Applications Processors	<a href="http://www.ti.com/omap">www.ti.com/omap</a>
Wireless Connectivity	<a href="http://www.ti.com/wirelessconnectivity">www.ti.com/wirelessconnectivity</a>

### Applications

Automotive and Transportation	<a href="http://www.ti.com/automotive">www.ti.com/automotive</a>
Communications and Telecom	<a href="http://www.ti.com/communications">www.ti.com/communications</a>
Computers and Peripherals	<a href="http://www.ti.com/computers">www.ti.com/computers</a>
Consumer Electronics	<a href="http://www.ti.com/consumer-apps">www.ti.com/consumer-apps</a>
Energy and Lighting	<a href="http://www.ti.com/energy">www.ti.com/energy</a>
Industrial	<a href="http://www.ti.com/industrial">www.ti.com/industrial</a>
Medical	<a href="http://www.ti.com/medical">www.ti.com/medical</a>
Security	<a href="http://www.ti.com/security">www.ti.com/security</a>
Space, Avionics and Defense	<a href="http://www.ti.com/space-avionics-defense">www.ti.com/space-avionics-defense</a>
Video and Imaging	<a href="http://www.ti.com/video">www.ti.com/video</a>

### TI E2E Community

[e2e.ti.com](http://e2e.ti.com)