

SBS 1.1-COMPLIANT GAS GAUGE ENABLED WITH IMPEDANCE TRACK™ TECHNOLOGY FOR USE WITH THE bq29330

FEATURES

- Next Generation Patented Impedance Track™ Technology accurately Measures Available Charge in Li-Ion and Li-Polymer Batteries
- Better than 1% Error Over Lifetime of the Battery
- Instant Accuracy – No Learning Cycle Required
- Supports the Smart Battery Specification SBS V1.1
- Powerful 8-Bit RISC CPU With Ultra-Low Power Modes
- Works With the TI bq29330 Analog Front-End (AFE) Protection IC to Provide Complete Pack Electronics Solution
- Full Array of Programmable Protection Features
 - Voltage, Current and Temperature
- Fully Integrated High Accurate Clock
- Flexible Configuration for 2 to 4 Series Li-Ion and Li-Polymer Cells
- Integrated Field Programmable FLASH Memory Eliminates the Need for External Configuration Memory
- Smart Battery Charger Control Feature
- Two 16-Bit Delta-Sigma Converter
 - Accurate Voltage and Temperature Measurements
 - Integrating Coloumb Counter for Charge Flow
 - Better Than 0.65 nVh of Resolution
 - Self-Calibrating
- Supports SHA-1 Authentication
- 20-Pin TSSOP (PW)

APPLICATIONS

- Notebook PCs
- Medical and Test Equipment
- Portable Instrumentation

DESCRIPTION

The bq20z70-V110 SBS-compliant gas gauge IC, incorporating patented Impedance Track™ technology, is designed for battery-pack or in-system installation. The bq20z70-V110 measures and maintains an accurate record of available charge in Li-ion or Li-polymer batteries using its integrated high-performance analog peripherals. The bq20z70-V110 monitors capacity change, battery impedance, open-circuit voltage, and other critical parameters of the battery pack, and reports the information to the system host controller over a serial-communication bus. It is designed to work with the bq29330 analog front-end (AFE) protection IC to maximize functionality and safety, and minimize component count and cost in smart battery circuits.

The Impedance Track technology continuously analyzes the battery impedance, resulting in superior gas-gauging accuracy. This enables remaining capacity to be calculated with discharge rate, temperature, and cell aging all accounted for during each stage of every cycle.

AVAILABLE OPTIONS

T _A	PACKAGE	
	20-PIN TSSOP (PW) Tube	20-PIN TSSOP (PW) Tape & Reel
–40°C to 85°C	bq20z70-V110PW ⁽¹⁾	bq20z70-V110PWR ⁽²⁾

(1) A single tube quantity is 50 units.

(2) A single reel quantity is 2000 units



Please be aware that an important notice concerning availability, standard warranty, and use in critical applications of Texas Instruments semiconductor products and disclaimers thereto appears at the end of this data sheet.

IMPEDANCE TRACK is a trademark of Texas Instruments.

SYSTEM PARTITIONING DIAGRAM

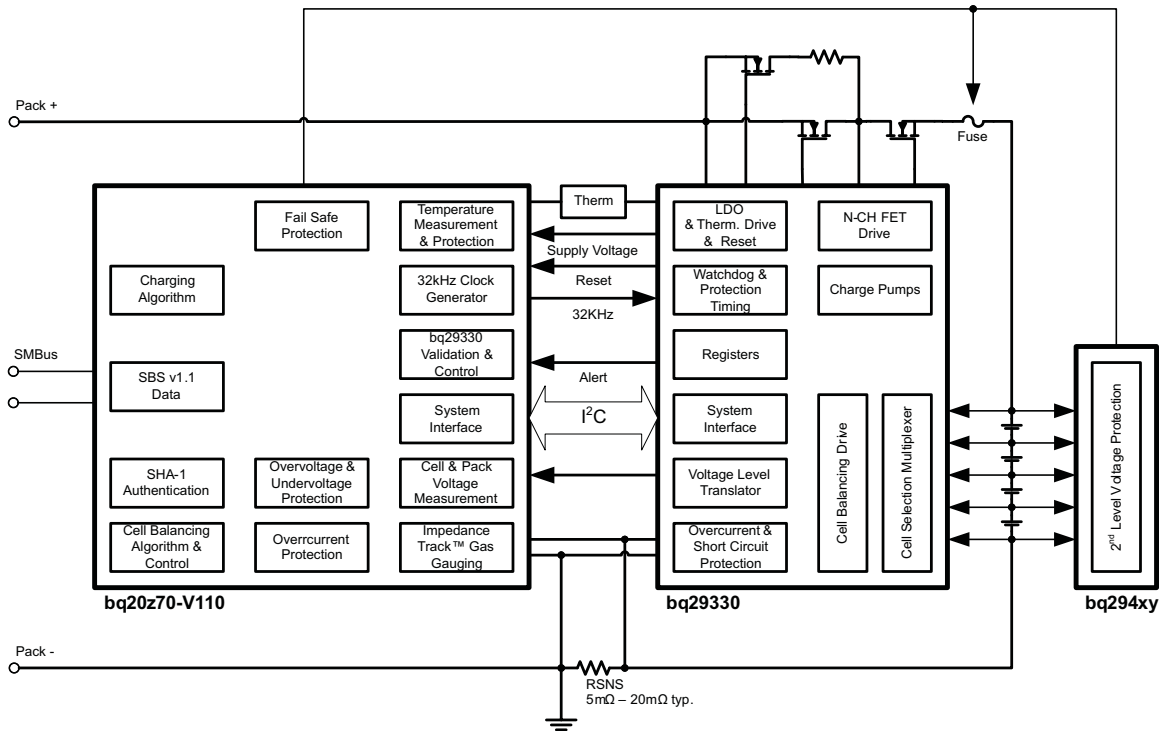

**TSSOP (PW)
(TOP VIEW)**

XALERT	1	20	VCELL-
TS2	2	19	VCELL+
TS1	3	18	VCC
CLKOUT	4	17	VSS
PRES	5	16	MRST
PFIN	6	15	SRN
SAFE	7	14	SRP
SMBD	8	13	VSS
NC	9	12	SCLK
SMBC	10	11	SDATA

TERMINAL FUNCTIONS

TERMINAL		I/O ⁽¹⁾	DESCRIPTION
NO.	NAME		
1	XALERT	I	Alert interrupt input from bq29330. Connect directly to bq29330 XALERT pin
2	TS2	I	2 nd thermistor voltage input connection to monitor temperature
3	TS1	I	1 st thermistor voltage input connection to monitor temperature
4	CLKOUT	O	32.768kHz output for bq29330 watchdog. Connect directly to bq29330 WDI pin
5	PRES	I	Active low input to sense system insertion
6	PFIN	I	Active low input to sense secondary protector output status
7	SAFE	O	Active high output to enforce additional level of safety, e.g. fuse blow
8	SMBD	I/OD	SMBus data open drain bidirectional pin used for communication with bq20z70-V110
9	NC	–	Not used - leave floating
10	SMBC	I/OD	SMBus clock open drain bidirectional pin used for communication with bq20z70-V110
11	SDATA	I/OD	Data transfer line from and to bq29330. Connect directly to SDATA pin of bq29330
12	SCLK	I/OD	Data clock line to bq29330. Connect directly to SCLK pin of bq29330
13	VSS	I/OD	VSS
14	SRP	IA	Connection for a small-value resistor to monitor the battery charge and discharge current flow
15	SRN	IA	Connection for a small-value resistor to monitor the battery charge and discharge current flow
16	MRST	I	Master reset input that forces the device into reset when held low. Connect directly to XRST pin of bq29330
17	VSS	P	Negative supply. Both VSS needs to be connected together
18	VCC	P	Positive supply
19	VCELL+	I	Positive differential cell input. Connect directly to CELL+ pin of bq29330
20	VCELL-	I	Negative differential cell input. Connect directly to CELL- pin of bq29330

(1) I = Input, IA = Analog input, I/O = Input/output, I/OD = Input/Open-drain output, O = Output, OA = Analog output, P = Power

ABSOLUTE MAXIMUM RATINGS

over operating free-air temperature range (unless otherwise noted)⁽¹⁾

		RANGE
V _{CC} relative to V _{SS} ⁽²⁾	Supply voltage range on VCC pin	–0.3 V to 2.75 V
V _(I/O) relative to V _{SS} ⁽²⁾	XALERT, PFIN, SAFE, SMBD, SMBC, SDATA, SCLK,	–0.3 V to 6.0 V
V _I relative to V _{SS} ⁽²⁾	TS2, TS1, CLKOUT, PRES, SRP, SRN, MRST, VCELL+, VCELL-	–0.3 V to V _{CC} + 0.3 V
T _A	Operating free-air temperature range	–40°C to 85°C
T _{stg}	Storage temperature range	–65°C to 150°C

(1) Stresses beyond those listed under absolute maximum ratings may cause permanent damage to the device. These are stress ratings only, and functional operation of the device at these or any other conditions beyond those indicated under recommended operating conditions is not implied. Exposure to absolute-maximum-rated conditions for extended periods may affect device reliability.

(2) V_{SS} refers to Voltage at VSS pin.

ELECTRICAL CHARACTERISTICS

V_{CC} = 2.4 V to 2.6 V, T_A = –40°C - 85°C (unless otherwise noted)

PARAMETER		TEST CONDITIONS	MIN	TYP	MAX	UNIT
V _{DD}	Supply voltage	VDDA and VDDD	2.4	2.5	2.6	V
I _{DD}	Operating mode current	No flash programming		400 ⁽¹⁾		μA
		bq20z70-V110 + bq29330		475		
I _(SLP)	Low-power storage mode current	Sleep mode		8 ⁽¹⁾		μA
		bq20z70-V110 + bq29330		48		

(1) This value does not include the bq29330

ELECTRICAL CHARACTERISTICS (continued)
 $V_{CC} = 2.4 \text{ V to } 2.6 \text{ V}$, $T_A = -40^\circ\text{C} - 85^\circ\text{C}$ (unless otherwise noted)

PARAMETER		TEST CONDITIONS	MIN	TYP	MAX	UNIT
$I_{(SLP)}$	Shutdown Current	Shutdown Mode		0.1 ⁽¹⁾		μA
		bq20z70-V110 + bq29330		0.2		
V_{OL}	Output voltage low CLKOUT, SAFE, SMBD, SMBC, SDATA, SCLK	$I_{OL} = 7 \text{ mA}$			0.4	V
V_{OH}	Output high voltage CLKOUT, SAFE, SMBD, SMBC, SDATA, SCLK	$I_{OH} = -0.5 \text{ mA}$	$V_{CC} - 0.5$			V
V_{IL}	Input voltage low $\overline{\text{PRES}}$, $\overline{\text{PFIN}}$, SMBD, SMBC, SDATA, $\overline{\text{MRST}}$				0.8	V
V_{IH}	Input voltage high $\overline{\text{PRES}}$, $\overline{\text{PFIN}}$, SMBD, SMBC, SDATA, $\overline{\text{MRST}}$		2.0			V
C_{IN}	Input capacitance			5		pF
$V_{(A1)}$	Input voltage range TS1, TS2, VCELL+, VCELL-		-0.2	$0.8 \times V_{CC}$		V
$V_{(A2)}$	Input voltage range SRP, SRN		-0.2	0.2		
$Z_{(A1)}$	Input impedance TS1, TS2, VCELL+, VCELL-	0 V – 1 V		8		$\text{M}\Omega$
$Z_{(A2)}$	Input impedance SRP, SRN	0 V – 1 V		2.5		$\text{M}\Omega$

POWER-ON RESET

$V_{CC} = 2.4\text{ V to }2.6\text{ V}$, $T_A = -40^\circ\text{C to }85^\circ\text{C}$ (unless otherwise noted)

PARAMETER	TEST CONDITIONS	MIN	TYP	MAX	UNIT
V_{IT-} Negative-going voltage input		1.7	1.8	1.9	V
V_{HYS} Power-on reset hysteresis		50	125	200	mV

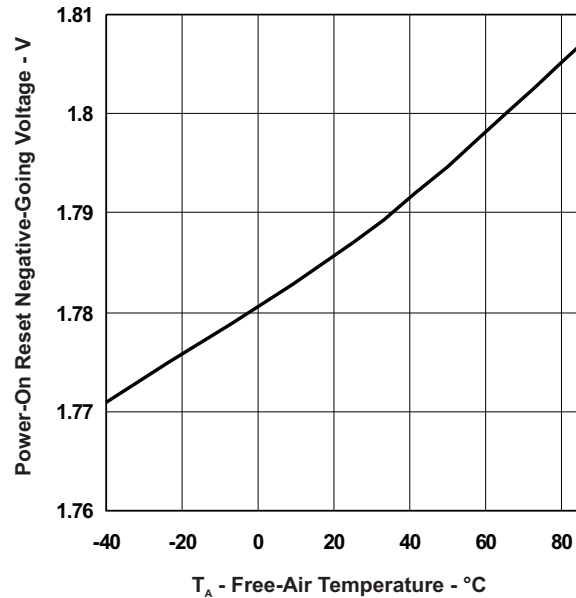

INTEGRATING ADC (Coulomb Counter) CHARACTERISTICS

$V_{CC} = 2.4\text{ V to }2.6\text{ V}$, $T_A = -40^\circ\text{C to }85^\circ\text{C}$ (unless otherwise noted)

PARAMETER	TEST CONDITIONS	MIN	TYP	MAX	UNIT
$V_{(SR)}$ Input voltage range, $V_{(SRN)}$ and $V_{(SRP)}$	$V_{(SR)} = V_{(SRP)} - V_{(SRN)}$	-0.20		0.20	V
$V_{(SROS)}$ Input offset	$T_A = 25^\circ\text{C to }85^\circ\text{C}$		10		μV
INL Integral nonlinearity error			± 0.007	± 0.037	%

OSCILLATOR

$V_{CC} = 2.4\text{ V to }2.6\text{ V}$, $T_A = -40^\circ\text{C to }85^\circ\text{C}$ (unless otherwise noted)

PARAMETER	TEST CONDITIONS	MIN	TYP	MAX	UNIT
HIGH FREQUENCY OSCILLATOR					
$f_{(OSC)}$ Operating frequency			4.194		MHz
$f_{(EIO)}$ Frequency error ⁽¹⁾⁽²⁾		-3%	0.25%	3%	
	$T_A = 20^\circ\text{C to }70^\circ\text{C}$	-2%	0.25%	2%	
$f_{(sxo)}$ Start-up time ⁽³⁾			2.5	5	ms
LOW FREQUENCY OSCILLATOR					
$f_{(LOSC)}$ Operating frequency			32.768		kHz
$f_{(LEIO)}$ Frequency error ⁽²⁾⁽⁴⁾		-2.5%	0.25%	2.5%	
	$T_A = 20^\circ\text{C to }70^\circ\text{C}$	-1.5%	0.25%	1.5%	
$f_{(Lsxo)}$ Start-up time ⁽⁵⁾				500	μs

- (1) The frequency error is measured from 4.194 MHz.
- (2) The frequency drift is included and measured from the trimmed frequency at $V_{CC} = 2.5\text{ V}$, $T_A = 25^\circ\text{C}$.
- (3) The start-up time is defined as the time it takes for the oscillator output frequency to be within 1% of the specified frequency.
- (4) The frequency error is measured from 32.768 kHz.
- (5) The start-up time is defined as the time it takes for the oscillator output frequency to be $\pm 3\%$.

DATA FLASH MEMORY CHARACTERISTICS
 $V_{CC} = 2.4\text{ V to }2.6\text{ V}$, $T_A = -40^\circ\text{C to }85^\circ\text{C}$ (unless otherwise noted)

PARAMETER		TEST CONDITIONS	MIN	TYP	MAX	UNIT
t_{DR}	Data retention	See ⁽¹⁾	10			Years
	Flash programming write-cycles	See ⁽¹⁾	20,000			Cycles
$t_{(WORDPROG)}$	Word programming time	See ⁽¹⁾			2	ms
$I_{(DDPROG)}$	Flash-write and erase supply current	See ⁽¹⁾		5	10	mA

(1) Assured by design. Not production tested

SMBus TIMING SPECIFICATIONS

$V_{CC} = 2.4\text{ V to }2.6\text{ V}$, $T_A = -40^\circ\text{C to }85^\circ\text{C}$ (unless otherwise noted)

PARAMETER		TEST CONDITIONS	MIN	TYP	MAX	UNIT
f_{SMB}	SMBus operating frequency	Slave mode, SMBC 50% duty cycle	10		100	kHz
f_{MAS}	SMBus master clock frequency	Master mode, no clock low slave extend		51.2		
t_{BUF}	Bus free time between start and stop		4.7			μs
$t_{HD:STA}$	Hold time after (repeated) start		4			
$t_{SU:STA}$	Repeated start setup time		4.7			
$t_{SU:STO}$	Stop setup time		4			
$t_{HD:DAT}$	Data hold time	Receive mode	0			
		Transmit mode	300			
$t_{SU:DAT}$	Data setup time		250			
$t_{TIMEOUT}$	Error signal/detect	See (1)	25		35	ms
t_{LOW}	Clock low period		4.7			μs
t_{HIGH}	Clock high period	See (2)	4		50	
$t_{LOW:SEXT}$	Cumulative clock low slave extend time	See (3)			25	ms
$t_{LOW:MEXT}$	Cumulative clock low master extend time	See (4)			10	
t_F	Clock/data fall time	$(V_{ILMAX} - 0.15\text{ V})$ to $(V_{IHMIN} + 0.15\text{ V})$			300	ns
t_R	Clock/data rise time	$0.9\text{ VCC to } (V_{ILMAX} - 0.15\text{ V})$			1000	

- (1) The bq20z70-V110 times out when any clock low exceeds $t_{TIMEOUT}$.
- (2) $t_{HIGH:MAX}$ is minimum bus idle time. SMBC = 1 for $t > 50\ \mu\text{s}$ causes reset of any transaction involving the bq20z70-V110 that is in progress.
- (3) $t_{LOW:SEXT}$ is the cumulative time a slave device is allowed to extend the clock cycles in one message from initial start to the stop.
- (4) $t_{LOW:MEXT}$ is the cumulative time a master device is allowed to extend the clock cycles in one message from initial start to the stop.

SMBus TIMING DIAGRAM

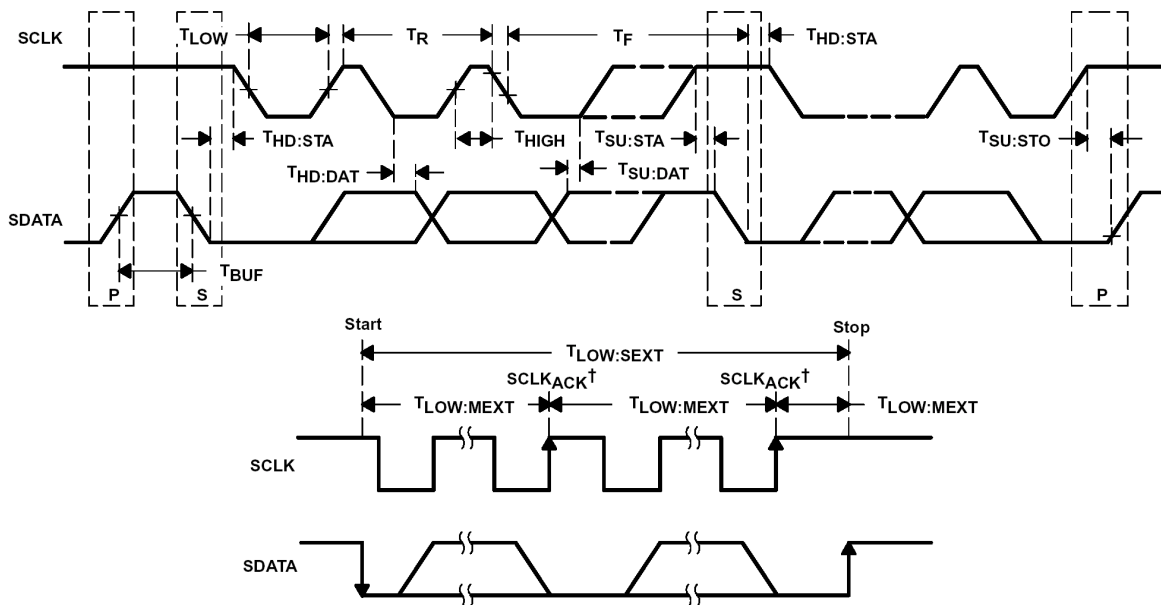

$\dagger SCLK_{ACK}$ is the acknowledge-related clock pulse generated by the master.

FEATURE SET

Primary (1st Level) Safety Features

The bq20z70-V110 supports a wide range of battery and system protection features that can easily be configured. The primary safety features include:

- Cell over/under voltage protection
- Charge and Discharge over current
- Short Circuit
- Charge and Discharge Over temperature
- AFE Watchdog

Secondary (2nd Level) Safety Features

The secondary safety features of the bq20z70-V110 can be used to indicate more serious faults via the SAFE (pin 7). This pin can be used to blow an in-line fuse to permanently disable the battery pack from charging or discharging. The secondary safety protection features include:

- Safety over voltage
- Safety over current in Charge and Discharge
- Safety over temperature in Charge and Discharge
- Charge FET and 0 Volt Charge FET fault
- Discharge FET fault
- AFE communication fault

Charge Control Features

The bq20z70-V110 charge control features include:

- Reports the appropriate charging current needed for constant current charging and the appropriate charging voltage needed for constant voltage charging to a smart charger using SMBus broadcasts.
- Determines the chemical state of charge of each battery cell using Impedance Track™ and can reduce the charge difference of the battery cells in fully charged state of the battery pack gradually using cell balancing algorithm during charging. This prevents fully charged cells from overcharging and causing excessive degradation and also increases the usable pack energy by preventing premature charge termination
- Supports pre-charging/zero-volt charging
- Support fast charging
- Supports charge inhibit and charge suspend if battery pack temperature is out of temperature range
- Reports charging fault and also indicate charge status via charge and discharge alarms.

Gas Gauging

The bq20z70-V110 uses the Impedance Track™ Technology to measure and calculate the available charge in battery cells. The achievable accuracy is better than 1% error over the lifetime of the battery and there is no full charge discharge learning cycle required.

See *Theory and Implementation of Impedance Track Battery Fuel-Gauging Algorithm* application note (SLUA364) for further details.

Authentication

The bq20z70-V110 supports authentication by the host using SHA-1.

Power Modes

The bq20z70-V110 supports 3 different power modes to reduce power consumption:

- In Normal Mode, the bq20z70-V110 performs measurements, calculations, protection decisions and data updates in 1 second intervals. Between these intervals, the bq20z70-V110 is in a reduced power stage.

FEATURE SET (continued)

- In Sleep Mode, the bq20z70-V110 performs measurements, calculations, protection decisions and data update in adjustable time intervals. Between these intervals, the bq20z70-V110 is in a reduced power stage. The bq20z70-V110 has a wake function that enables exit from Sleep mode, when current flow or failure is detected.
- In Shutdown Mode the bq20z70-V110 is completely disabled.

CONFIGURATION

Oscillator Function

The bq20z70-V110 fully integrates the system oscillators. Therefore the bq20z70-V110 requires no external components for this feature.

System Present Operation

The bq20z70-V110 pulls the PU pin high periodically (1 s). Connect this pin to the $\overline{\text{PRES}}$ pin of the bq20z70-V110 via a resistor of approximately 5 k Ω . The bq20z70-V110 measures the $\overline{\text{PRES}}$ input during the PU-active period to determine its state. If $\overline{\text{PRES}}$ input is pulled to ground by external system, the bq20z70-V110 detects this as system present.

BATTERY PARAMETER MEASUREMENTS

The bq20z70-V110 uses an integrating delta-sigma analog-to-digital converter (ADC) for current measurement, and a second delta-sigma ADC for individual cell and battery voltage, and temperature measurement.

Charge and Discharge Counting

The integrating delta-sigma ADC measures the charge/discharge flow of the battery by measuring the voltage drop across a small-value sense resistor between the SR1 and SR2 pins. The integrating ADC measures bipolar signals from -0.25 V to 0.25 V. The bq20z70-V110 detects charge activity when $V_{\text{SR}} = V_{(\text{SR}1)} - V_{(\text{SR}2)}$ is positive and discharge activity when $V_{\text{SR}} = V_{(\text{SR}1)} - V_{(\text{SR}2)}$ is negative. The bq20z70-V110 continuously integrates the signal over time, using an internal counter. The fundamental rate of the counter is 0.65 nVh.

Voltage

The bq20z70-V110 updates the individual series cell voltages through the bq29330 at one second intervals. The bq20z70-V110 configures the bq29330 to connect the selected cell, cell offset, or bq29330 VREF to the CELL pin of the bq29330, which is required to be connected to VIN of the bq20z70-V110. The internal ADC of the bq20z70-V110 measures the voltage, scales and calibrates it appropriately. This data is also used to calculate the impedance of the cell for the Impedance Track™ gas-gauging.

Current

The bq20z70-V110 uses the SRP and SRN inputs to measure and calculate the battery charge and discharge current using a 5 m Ω to 20 m Ω typ. sense resistor.

Auto Calibration

The bq20z70-V110 provides an auto-calibration feature to cancel the voltage offset error across SRN and SRP for maximum charge measurement accuracy. The bq20z70-V110 performs auto-calibration when the SMBus lines stay low continuously for a minimum of 5 s.

Temperature

The bq20z70-V110 has an internal temperature sensor and 2 external temperature sensor inputs TS1 and TS2 used in conjunction with two identical NTC thermistors (default are Semitec 103AT) to sense the battery environmental temperature. The bq20z70-V110 can be configured to use internal or external temperature sensors.

FEATURE SET (continued)**COMMUNICATIONS**

The bq20z70-V110 uses SMBus v1.1 with Master Mode and package error checking (PEC) options per the SBS specification.

SMBus On and Off State

The bq20z70-V110 detects an SMBus off state when SMBC and SMBD are logic-low for ≥ 2 seconds. Clearing this state requires either SMBC or SMBD to transition high. Within 1 ms, the communication bus is available.

FEATURE SET (continued)
SBS and Dataflash Values
Table 1. SBS COMMANDS

SBS Cmd	Mode	Name	Format	Size in Bytes	Min Value	Max Value	Default Value	Unit
0x00	R/W	ManufacturerAccess	hex	2	0x0000	0xffff	—	
0x01	R/W	RemainingCapacityAlarm	unsigned int	2	0	65535	—	mAh or 10mWh
0x02	R/W	RemainingTimeAlarm	unsigned int	2	0	65535	—	min
0x03	R/W	BatteryMode	hex	2	0x0000	0xffff	—	
0x04	R/W	AtRate	signed int	2	-32768	32767	—	mA or 10mW
0x05	R	AtRateTimeToFull	unsigned int	2	0	65535	—	min
0x06	R	AtRateTimeToEmpty	unsigned int	2	0	65535	—	min
0x07	R	AtRateOK	unsigned int	2	0	65535	—	
0x08	R	Temperature	unsigned int	2	0	65535	—	0.1°K
0x09	R	Voltage	unsigned int	2	0	20000	—	mV
0x0a	R	Current	signed int	2	-32768	32767	—	mA
0x0b	R	AverageCurrent	signed int	2	-32768	32767	—	mA
0x0c	R	MaxError	unsigned int	1	0	100	—	%
0x0d	R	RelativeStateOfCharge	unsigned int	1	0	100	—	%
0x0e	R	AbsoluteStateOfCharge	unsigned int	1	0	100	—	%
0x0f	R/W	RemainingCapacity	unsigned int	2	0	65535	—	mAh or 10mWh
0x10	R	FullChargeCapacity	unsigned int	2	0	65535	—	mAh or 10mWh
0x11	R	RunTimeToEmpty	unsigned int	2	0	65535	—	min
0x12	R	AverageTimeToEmpty	unsigned int	2	0	65535	—	min
0x13	R	AverageTimeToFull	unsigned int	2	0	65535	—	min
0x14	R	ChargingCurrent	unsigned int	2	0	65535	—	mA
0x15	R	ChargingVoltage	unsigned int	2	0	65535	—	mV
0x16	R	BatteryStatus	unsigned int	2	0x0000	0xffff	—	
0x17	R/W	CycleCount	unsigned int	2	0	65535	—	
0x18	R/W	DesignCapacity	unsigned int	2	0	65535	—	mAh or 10mWh
0x19	R/W	DesignVoltage	unsigned int	2	7000	16000	14400	mV
0x1a	R/W	SpecificationInfo	unsigned int	2	0x0000	0xffff	0x0031	
0x1b	R/W	ManufactureDate	unsigned int	2	0	65535	0	
0x1c	R/W	SerialNumber	hex	2	0x0000	0xffff	0x0001	
0x20	R/W	ManufacturerName	String	11+1	—	—	Texas Instruments	ASCII
0x21	R/W	DeviceName	String	7+1	—	—	bq20z70-V110	ASCII
0x22	R/W	DeviceChemistry	String	4+1	—	—	LION	ASCII
0x23	R	ManufacturerData	String	14+1	—	—	—	ASCII
0x2f	R/W	Authenticate	String	20+1	—	—	—	ASCII
0x3c	R	CellVoltage4	unsigned int	2	0	65535	—	mV
0x3d	R	CellVoltage3	unsigned int	2	0	65535	—	mV
0x3e	R	CellVoltage2	unsigned int	2	0	65535	—	mV
0x3f	R	CellVoltage1	unsigned int	2	0	65535	—	mV

Table 2. EXTENDED SBS COMMANDS

SBS Cmd	Mode	Name	Format	Size in Bytes	Min Value	Max Value	Default Value	Unit
0x45	R	AFEData	String	11+1	—	—	—	ASCII
0x46	R/W	FETControl	hex	1	0x00	0xff	—	
0x4f	R	StateOfHealth	unsigned int	1	0	100	—	%
0x51	R	SafetyStatus	hex	2	0x0000	0xffff	—	
0x53	R	PFStatus	hex	2	0x0000	0xffff	—	
0x54	R	OperationStatus	hex	2	0x0000	0xffff	—	
0x55	R	ChargingStatus	hex	2	0x0000	0xffff	—	
0x57	R	ResetData	hex	2	0x0000	0xffff	—	
0x5a	R	PackVoltage	unsigned int	2	0	65535	—	mV
0x5d	R	AverageVoltage	unsigned int	2	0	65535	—	mV
0x60	R/W	UnSealKey	hex	4	0x00000000	0xffffffff	—	
0x61	R/W	FullAccessKey	hex	4	0x00000000	0xffffffff	—	
0x62	R/W	PFKey	hex	4	0x00000000	0xffffffff	—	
0x63	R/W	AuthenKey3	hex	4	0x00000000	0xffffffff	—	
0x64	R/W	AuthenKey2	hex	4	0x00000000	0xffffffff	—	
0x65	R/W	AuthenKey1	hex	4	0x00000000	0xffffffff	—	
0x66	R/W	AuthenKey0	hex	4	0x00000000	0xffffffff	—	
0x70	R/W	ManufacturerInfo	String	8+1	—	—	—	
0x71	R/W	SenseResistor	unsigned int	2	0	65535	—	$\mu\Omega$
0x77	R/W	DataFlashSubClassID	hex	2	0x0000	0xffff	—	
0x78	R/W	DataFlashSubClassPage1	hex	32	—	—	—	
0x79	R/W	DataFlashSubClassPage2	hex	32	—	—	—	
0x7a	R/W	DataFlashSubClassPage3	hex	32	—	—	—	
0x7b	R/W	DataFlashSubClassPage4	hex	32	—	—	—	
0x7c	R/W	DataFlashSubClassPage5	hex	32	—	—	—	
0x7d	R/W	DataFlashSubClassPage6	hex	32	—	—	—	
0x7e	R/W	DataFlashSubClassPage7	hex	32	—	—	—	
0x7f	R/W	DataFlashSubClassPage8	hex	32	—	—	—	

NOTE:

All reserved bits in Data Flash should be written to zero.

Table 3. DATAFLASH VALUES

Class	Subclass ID	Subclass	Offset	Name	Data Type	Min Value	Max Value	Default Value	Units
1st Level Safety	0	Voltage	0	COV Threshold	I2	3700	5000	4300	mV
1st Level Safety	0	Voltage	3	COV Recovery	I2	0	4400	3900	mV
1st Level Safety	0	Voltage	12	CUV Threshold	I2	0	3500	2200	mV
1st Level Safety	0	Voltage	15	CUV Recovery	I2	0	3600	3000	mV
1st Level Safety	1	Current	0	OC (1st Tier) Chg	I2	0	20000	6000	mA
1st Level Safety	1	Current	5	OC (1st Tier) Dsg	I2	0	20000	6000	mA
1st Level Safety	1	Current	16	Current Recovery Time	U1	0	240	8	Sec
1st Level Safety	1	Current	17	AFE OC Dsg	H1	0x00	0x1f	0x12	
1st Level Safety	1	Current	18	AFE OC Dsg Time	H1	0x00	0xff	0x0f	
1st Level Safety	1	Current	21	AFE SC Chg Cfg	H1	0x00	0xff	0x77	
1st Level Safety	1	Current	22	AFE SC Dsg Cfg	H1	0x00	0xff	0x77	
1st Level Safety	2	Temperature	0	Over Temp Chg	I2	0	1200	550	0.1°C
1st Level Safety	2	Temperature	3	OT Chg Recovery	I2	0	1200	500	0.1°C
1st Level Safety	2	Temperature	5	Over Temp Dsg	I2	0	1200	600	0.1°C

Table 3. DATAFLASH VALUES (continued)

Class	Subclass ID	Subclass	Offset	Name	Data Type	Min Value	Max Value	Default Value	Units
1st Level Safety	2	Temperature	8	OT Dsg Recovery	I2	0	1200	550	0.1°C
2nd Level Safety	16	Voltage	0	SOV Threshold	I2	0	20000	18000	mV
2nd Level Safety	16	Voltage	2	SOV Time	U1	0	240	0	Sec
2nd Level Safety	16	Voltage	3	Cell Imbalance Current	I1	0	200	5	mA
2nd Level Safety	16	Voltage	4	Cell Imbalance Fail Voltage	I2	0	5000	1000	mV
2nd Level Safety	16	Voltage	6	Cell Imbalance Time	U1	0	240	0	Sec
2nd Level Safety	16	Voltage	7	Battery Rest Time	U2	0	65535	1800	Sec
2nd Level Safety	16	Voltage	9	PFIN Detect Time	U1	0	240	0	Sec
2nd Level Safety	17	Current	0	SOC Chg	I2	0	30000	10000	mA
2nd Level Safety	17	Current	2	SOC Chg Time	U1	0	240	0	Sec
2nd Level Safety	17	Current	3	SOC Dsg	I2	0	30000	10000	mA
2nd Level Safety	17	Current	5	SOC Dsg Time	U1	0	240	0	Sec
2nd Level Safety	18	Temperature	0	SOT Chg	I2	0	1200	650	0.1°C
2nd Level Safety	18	Temperature	2	SOT Chg Time	U1	0	240	0	Sec
2nd Level Safety	18	Temperature	3	SOT Dsg	I2	0	1200	750	0.1°C
2nd Level Safety	18	Temperature	5	SOT Dsg Time	U1	0	240	0	Sec
2nd Level Safety	19	FET Verification	2	FET Fail Time	U1	0	240	0	Sec
2nd Level Safety	20	AFE Verification	1	AFE Fail Limit	U1	0	255	10	
Charge Control	32	Charge Inhibit Cfg	0	Chg Inhibit Temp Low	I2	-400	1200	0	0.1°C
Charge Control	32	Charge Inhibit Cfg	2	Chg Inhibit Temp High	I2	-400	1200	450	0.1°C
Charge Control	33	Pre-Charge Cfg	0	Pre-chg Current	I2	0	2000	250	mA
Charge Control	33	Pre-Charge Cfg	2	Pre-chg Temp	I2	-400	1200	120	0.1°C
Charge Control	33	Pre-Charge Cfg	4	Pre-chg Voltage	I2	0	20000	3000	mV
Charge Control	33	Pre-Charge Cfg	6	Recovery Voltage	I2	0	20000	3100	mV
Charge Control	34	Fast Charge Cfg	0	Fast Charge Current	I2	0	10000	4000	mA
Charge Control	34	Fast Charge Cfg	2	Charging Voltage	I2	0	20000	16800	mV
Charge Control	34	Fast Charge Cfg	6	Suspend Low Temp	I2	-400	1200	-50	0.1°C
Charge Control	34	Fast Charge Cfg	8	Suspend High Temp	I2	-400	1200	550	0.1°C
Charge Control	36	Termination Cfg.	2	Taper Current	I2	0	1000	250	mA
Charge Control	36	Termination Cfg.	6	Taper Voltage	I2	0	1000	300	mV
Charge Control	36	Termination Cfg.	10	TCA Clear %	I1	-1	100	95	%
Charge Control	36	Termination Cfg.	12	FC Clear %	I1	-1	100	98	%
Charge Control	37	Cell Balancing Cfg	0	Min Cell Deviation	U2	0	65535	1750	Sec/mAh
Charge Control	38	Charging Faults	13	Over Charge Capacity	I2	0	4000	300	mAh
Charge Control	38	Charging Faults	21	Charge Fault Cfg	H1	0x00	0x02	0x00	
SBS Configuration	48	Data	0	Rem Cap Alarm	I2	0	700	300	mAh
SBS Configuration	48	Data	2	Rem Energy Alarm	I2	0	1000	432	10mWh
SBS Configuration	48	Data	4	Rem Time Alarm	U2	0	30	10	min
SBS Configuration	48	Data	6	Init Battery Mode	H2	0x0000	0xffff	0x0081	
SBS Configuration	48	Data	8	Design Voltage	I2	7000	18000	14400	mV
SBS Configuration	48	Data	10	Spec Info	H2	0x0000	0xffff	0x0031	
SBS Configuration	48	Data	12	Manuf Date	U2	0	65535	0	Day + Mo*32 + (Yr - 1980)*256
SBS Configuration	48	Data	14	Ser. Num.	H2	0x0000	0xffff	0x0001	
SBS Configuration	48	Data	16	Cycle Count	U2	0	65535	0	
SBS Configuration	48	Data	18	CC Threshold	I2	100	32767	4400	mAh
SBS Configuration	48	Data	21	CF MaxError Limit	U1	0	100	100	%
SBS Configuration	48	Data	22	Design Capacity	I2	0	65535	4400	mAh
SBS Configuration	48	Data	24	Design Energy	I2	0	65535	6336	0.1Wh

Table 3. DATAFLASH VALUES (continued)

Class	Subclass ID	Subclass	Offset	Name	Data Type	Min Value	Max Value	Default Value	Units
SBS Configuration	48	Data	26	Manuf Name	S12	-	-	Texas Inst.	ASCII
SBS Configuration	48	Data	38	Device Name	S8	-	-	bq20z70-V110	ASCII
SBS Configuration	48	Data	46	Device Chemistry	S5	-	-	LION	ASCII
SBS Configuration	49	Configuration	0	TDA Set %	I1	-1	100	6	%
SBS Configuration	49	Configuration	1	TDA Clear %	I1	-1	100	8	%
SBS Configuration	49	Configuration	2	FD Set %	I1	-1	100	2	%
SBS Configuration	49	Configuration	3	FD Clear %	I1	-1	100	5	%
SBS Configuration	49	Configuration	4	TDA Set Volt Threshold	I2	0	16800	5000	mV
SBS Configuration	49	Configuration	6	TDA Set Volt Time	U1	0	240	0	Sec
SBS Configuration	49	Configuration	7	TDA Clear Volt	I2	0	16800	5500	mV
System Data	58	Manufacturer Info	0	Manuf. Info	S9			01234567 89abcdef0 123	ASCII
Configuration	64	Registers	0	Operation Cfg A	H2	0x0000	0x033b	0x033b	
Configuration	64	Registers	2	Operation Cfg B	H2	0x0000	0x3eff	0x2440	
Configuration	64	Registers	4	Operation Cfg C	H2	0x0000	0x0001	0x0000	
Configuration	64	Registers	6	Permanent Fail Cfg	H2	0x0000	0x4dff	0x0000	
Configuration	64	Registers	8	Non-Removable Cfg	H2	0x0000	0x3027	0x0000	
Power	68	Power	0	Flash Update OK Voltage	I2	6000	20000	7500	mV
Power	68	Power	2	Shutdown Voltage	I2	5000	20000	7000	mV
Power	68	Power	5	Charger Present	I2	0	23000	3000	mV
Power	68	Power	16	Wake Current Reg	H1	0x00	0xff	0x00	
Gas Gauging	80	IT Cfg	0	Load Select	U1	0	255	3	
Gas Gauging	80	IT Cfg	1	Load Mode	U1	0	255	0	
Gas Gauging	80	IT Cfg	45	Term Voltage	I2	-32768	32767	12000	mV
Gas Gauging	80	IT Cfg	60	User Rate-mA	I2	-9000	-2000	0	mA
Gas Gauging	80	IT Cfg	62	User Rate-mW	I2	-14000	-3000	0	0.1W
Gas Gauging	80	IT Cfg	64	Reserve Cap-mAh	I2	0	9000	0	mAh
Gas Gauging	80	IT Cfg	66	Reserve Cap-mWh	I2	0	14000	0	0.1Wh
Gas Gauging	81	Current Thresholds	0	Dsg Current Threshold	I2	0	2000	50	mA
Gas Gauging	81	Current Thresholds	2	Chg Current Threshold	I2	0	2000	25	mA
Gas Gauging	81	Current Thresholds	4	Quit Current	I2	0	1000	10	mA
Gas Gauging	82	State	0	Qmax Cell0	I2	0	65535	4400	mAh
Gas Gauging	82	State	2	Qmax Cell1	I2	0	65535	4400	mAh
Gas Gauging	82	State	4	Qmax Cell2	I2	0	65535	4400	mAh
Gas Gauging	82	State	6	Qmax Cell3	I2	0	65535	4400	mAh
Gas Gauging	82	State	8	Qmax Pack	I2	0	65535	4400	mAh
Gas Gauging	82	State	12	Update Status	H1	0x00	0x03	0x00	
Gas Gauging	82	State	25	Delta Voltage	I2	-32768	32767	0	mV
Ra Table	88	R_a0	0	Cell0 R_a flag	H2	0x0000	0xffff	0xff55	
Ra Table	88	R_a0	2	Cell0 R_a 0	I2	0	32767	160	2~10ohm
Ra Table	88	R_a0	4	Cell0 R_a 1	I2	0	32767	166	2~10ohm
Ra Table	88	R_a0	6	Cell0 R_a 2	I2	0	32767	153	2~10ohm
Ra Table	88	R_a0	8	Cell0 R_a 3	I2	0	32767	151	2~10ohm
Ra Table	88	R_a0	10	Cell0 R_a 4	I2	0	32767	145	2~10ohm
Ra Table	88	R_a0	12	Cell0 R_a 5	I2	0	32767	152	2~10ohm
Ra Table	88	R_a0	14	Cell0 R_a 6	I2	0	32767	176	2~10ohm
Ra Table	88	R_a0	16	Cell0 R_a 7	I2	0	32767	204	2~10ohm

Table 3. DATAFLASH VALUES (continued)

Class	Subclass ID	Subclass	Offset	Name	Data Type	Min Value	Max Value	Default Value	Units
Ra Table	88	R_a0	18	Cell0 R_a 8	I2	0	32767	222	2 [~] 10ohm
Ra Table	88	R_a0	20	Cell0 R_a 9	I2	0	32767	254	2 [~] 10ohm
Ra Table	88	R_a0	22	Cell0 R_a 10	I2	0	32767	315	2 [~] 10ohm
Ra Table	88	R_a0	24	Cell0 R_a 11	I2	0	32767	437	2 [~] 10ohm
Ra Table	88	R_a0	26	Cell0 R_a 12	I2	0	32767	651	2 [~] 10ohm
Ra Table	88	R_a0	28	Cell0 R_a 13	I2	0	32767	1001	2 [~] 10ohm
Ra Table	88	R_a0	30	Cell0 R_a 14	I2	0	32767	1458	2 [~] 10ohm
Ra Table	89	R_a1	0	Cell1 R_a flag	H2	0x0000	0xffff	0xff55	
Ra Table	89	R_a1	2	Cell1 R_a 0	I2	0	32767	160	2 [~] 10ohm
Ra Table	89	R_a1	4	Cell1 R_a 1	I2	0	32767	166	2 [~] 10ohm
Ra Table	89	R_a1	6	Cell1 R_a 2	I2	0	32767	153	2 [~] 10ohm
Ra Table	89	R_a1	8	Cell1 R_a 3	I2	0	32767	151	2 [~] 10ohm
Ra Table	89	R_a1	10	Cell1 R_a 4	I2	0	32767	145	2 [~] 10ohm
Ra Table	89	R_a1	12	Cell1 R_a 5	I2	0	32767	152	2 [~] 10ohm
Ra Table	89	R_a1	14	Cell1 R_a 6	I2	0	32767	176	2 [~] 10ohm
Ra Table	89	R_a1	16	Cell1 R_a 7	I2	0	32767	204	2 [~] 10ohm
Ra Table	89	R_a1	18	Cell1 R_a 8	I2	0	32767	222	2 [~] 10ohm
Ra Table	89	R_a1	20	Cell1 R_a 9	I2	0	32767	254	2 [~] 10ohm
Ra Table	89	R_a1	22	Cell1 R_a 10	I2	0	32767	315	2 [~] 10ohm
Ra Table	89	R_a1	24	Cell1 R_a 11	I2	0	32767	437	2 [~] 10ohm
Ra Table	89	R_a1	26	Cell1 R_a 12	I2	0	32767	651	2 [~] 10ohm
Ra Table	89	R_a1	28	Cell1 R_a 13	I2	0	32767	1001	2 [~] 10ohm
Ra Table	89	R_a1	30	Cell1 R_a 14	I2	0	32767	1458	2 [~] 10ohm
Ra Table	90	R_a2	0	Cell2 R_a flag	H2	0x0000	0xffff	0xff55	
Ra Table	90	R_a2	2	Cell2 R_a 0	I2	0	32767	160	2 [~] 10ohm
Ra Table	90	R_a2	4	Cell2 R_a 1	I2	0	32767	166	2 [~] 10ohm
Ra Table	90	R_a2	6	Cell2 R_a 2	I2	0	32767	153	2 [~] 10ohm
Ra Table	90	R_a2	8	Cell2 R_a 3	I2	0	32767	151	2 [~] 10ohm
Ra Table	90	R_a2	10	Cell2 R_a 4	I2	0	32767	145	2 [~] 10ohm
Ra Table	90	R_a2	12	Cell2 R_a 5	I2	0	32767	152	2 [~] 10ohm
Ra Table	90	R_a2	14	Cell2 R_a 6	I2	0	32767	176	2 [~] 10ohm
Ra Table	90	R_a2	16	Cell2 R_a 7	I2	0	32767	204	2 [~] 10ohm
Ra Table	90	R_a2	18	Cell2 R_a 8	I2	0	32767	222	2 [~] 10ohm
Ra Table	90	R_a2	20	Cell2 R_a 9	I2	0	32767	254	2 [~] 10ohm
Ra Table	90	R_a2	22	Cell2 R_a 10	I2	0	32767	315	2 [~] 10ohm
Ra Table	90	R_a2	24	Cell2 R_a 11	I2	0	32767	437	2 [~] 10ohm
Ra Table	90	R_a2	26	Cell2 R_a 12	I2	0	32767	651	2 [~] 10ohm
Ra Table	90	R_a2	28	Cell2 R_a 13	I2	0	32767	1001	2 [~] 10ohm
Ra Table	90	R_a2	30	Cell2 R_a 14	I2	0	32767	1458	2 [~] 10ohm
Ra Table	91	R_a3	0	Cell3 R_a flag	H2	0x0000	0xffff	0xff55	
Ra Table	91	R_a3	2	Cell3 R_a 0	I2	0	32767	160	2 [~] 10ohm
Ra Table	91	R_a3	4	Cell3 R_a 1	I2	0	32767	166	2 [~] 10ohm
Ra Table	91	R_a3	6	Cell3 R_a 2	I2	0	32767	153	2 [~] 10ohm
Ra Table	91	R_a3	8	Cell3 R_a 3	I2	0	32767	151	2 [~] 10ohm
Ra Table	91	R_a3	10	Cell3 R_a 4	I2	0	32767	145	2 [~] 10ohm
Ra Table	91	R_a3	12	Cell3 R_a 5	I2	0	32767	152	2 [~] 10ohm
Ra Table	91	R_a3	14	Cell3 R_a 6	I2	0	32767	176	2 [~] 10ohm
Ra Table	91	R_a3	16	Cell3 R_a 7	I2	0	32767	204	2 [~] 10ohm
Ra Table	91	R_a3	18	Cell3 R_a 8	I2	0	32767	222	2 [~] 10ohm
Ra Table	91	R_a3	20	Cell3 R_a 9	I2	0	32767	254	2 [~] 10ohm

Table 3. DATAFLASH VALUES (continued)

Class	Subclass ID	Subclass	Offset	Name	Data Type	Min Value	Max Value	Default Value	Units
Ra Table	91	R_a3	22	Cell3 R_a 10	I2	0	32767	315	2 [~] 10ohm
Ra Table	91	R_a3	24	Cell3 R_a 11	I2	0	32767	437	2 [~] 10ohm
Ra Table	91	R_a3	26	Cell3 R_a 12	I2	0	32767	651	2 [~] 10ohm
Ra Table	91	R_a3	28	Cell3 R_a 13	I2	0	32767	1001	2 [~] 10ohm
Ra Table	91	R_a3	30	Cell3 R_a 14	I2	0	32767	1458	2 [~] 10ohm
Ra Table	92	R_a0x	0	xCell0 R_a flag	H2	0x0000	0xffff	0xffff	
Ra Table	92	R_a0x	2	xCell0 R_a 0	I2	0	32767	160	2 [~] 10ohm
Ra Table	92	R_a0x	4	xCell0 R_a 1	I2	0	32767	166	2 [~] 10ohm
Ra Table	92	R_a0x	6	xCell0 R_a 2	I2	0	32767	153	2 [~] 10ohm
Ra Table	92	R_a0x	8	xCell0 R_a 3	I2	0	32767	151	2 [~] 10ohm
Ra Table	92	R_a0x	10	xCell0 R_a 4	I2	0	32767	145	2 [~] 10ohm
Ra Table	92	R_a0x	12	xCell0 R_a 5	I2	0	32767	152	2 [~] 10ohm
Ra Table	92	R_a0x	14	xCell0 R_a 6	I2	0	32767	176	2 [~] 10ohm
Ra Table	92	R_a0x	16	xCell0 R_a 7	I2	0	32767	204	2 [~] 10ohm
Ra Table	92	R_a0x	18	xCell0 R_a 8	I2	0	32767	222	2 [~] 10ohm
Ra Table	92	R_a0x	20	xCell0 R_a 9	I2	0	32767	254	2 [~] 10ohm
Ra Table	92	R_a0x	22	xCell0 R_a 10	I2	0	32767	315	2 [~] 10ohm
Ra Table	92	R_a0x	24	xCell0 R_a 11	I2	0	32767	437	2 [~] 10ohm
Ra Table	92	R_a0x	26	xCell0 R_a 12	I2	0	32767	651	2 [~] 10ohm
Ra Table	92	R_a0x	28	xCell0 R_a 13	I2	0	32767	1001	2 [~] 10ohm
Ra Table	92	R_a0x	30	xCell0 R_a 14	I2	0	32767	1458	2 [~] 10ohm
Ra Table	93	R_a1x	0	xCell1 R_a flag	H2	0x0000	0xffff	0xffff	
Ra Table	93	R_a1x	2	xCell1 R_a 0	I2	0	32767	160	2 [~] 10ohm
Ra Table	93	R_a1x	4	xCell1 R_a 1	I2	0	32767	166	2 [~] 10ohm
Ra Table	93	R_a1x	6	xCell1 R_a 2	I2	0	32767	153	2 [~] 10ohm
Ra Table	93	R_a1x	8	xCell1 R_a 3	I2	0	32767	151	2 [~] 10ohm
Ra Table	93	R_a1x	10	xCell1 R_a 4	I2	0	32767	145	2 [~] 10ohm
Ra Table	93	R_a1x	12	xCell1 R_a 5	I2	0	32767	152	2 [~] 10ohm
Ra Table	93	R_a1x	14	xCell1 R_a 6	I2	0	32767	176	2 [~] 10ohm
Ra Table	93	R_a1x	16	xCell1 R_a 7	I2	0	32767	204	2 [~] 10ohm
Ra Table	93	R_a1x	18	xCell1 R_a 8	I2	0	32767	222	2 [~] 10ohm
Ra Table	93	R_a1x	20	xCell1 R_a 9	I2	0	32767	254	2 [~] 10ohm
Ra Table	93	R_a1x	22	xCell1 R_a 10	I2	0	32767	315	2 [~] 10ohm
Ra Table	93	R_a1x	24	xCell1 R_a 11	I2	0	32767	437	2 [~] 10ohm
Ra Table	93	R_a1x	26	xCell1 R_a 12	I2	0	32767	651	2 [~] 10ohm
Ra Table	93	R_a1x	28	xCell1 R_a 13	I2	0	32767	1001	2 [~] 10ohm
Ra Table	93	R_a1x	30	xCell1 R_a 14	I2	0	32767	1458	2 [~] 10ohm
Ra Table	94	R_a2x	0	xCell2 R_a flag	H2	0x0000	0xffff	0xffff	
Ra Table	94	R_a2x	2	xCell2 R_a 0	I2	0	32767	160	2 [~] 10ohm
Ra Table	94	R_a2x	4	xCell2 R_a 1	I2	0	32767	166	2 [~] 10ohm
Ra Table	94	R_a2x	6	xCell2 R_a 2	I2	0	32767	153	2 [~] 10ohm
Ra Table	94	R_a2x	8	xCell2 R_a 3	I2	0	32767	151	2 [~] 10ohm
Ra Table	94	R_a2x	10	xCell2 R_a 4	I2	0	32767	145	2 [~] 10ohm
Ra Table	94	R_a2x	12	xCell2 R_a 5	I2	0	32767	152	2 [~] 10ohm
Ra Table	94	R_a2x	14	xCell2 R_a 6	I2	0	32767	176	2 [~] 10ohm
Ra Table	94	R_a2x	16	xCell2 R_a 7	I2	0	32767	204	2 [~] 10ohm
Ra Table	94	R_a2x	18	xCell2 R_a 8	I2	0	32767	222	2 [~] 10ohm
Ra Table	94	R_a2x	20	xCell2 R_a 9	I2	0	32767	254	2 [~] 10ohm
Ra Table	94	R_a2x	22	xCell2 R_a 10	I2	0	32767	315	2 [~] 10ohm
Ra Table	94	R_a2x	24	xCell2 R_a 11	I2	0	32767	437	2 [~] 10ohm

Table 3. DATAFLASH VALUES (continued)

Class	Subclass ID	Subclass	Offset	Name	Data Type	Min Value	Max Value	Default Value	Units
Ra Table	94	R_a2x	26	xCell2 R_a 12	I2	0	32767	651	2 [~] 10ohm
Ra Table	94	R_a2x	28	xCell2 R_a 13	I2	0	32767	1001	2 [~] 10ohm
Ra Table	94	R_a2x	30	xCell2 R_a 14	I2	0	32767	1458	2 [~] 10ohm
Ra Table	95	R_a3x	0	xCell3 R_a flag	H2	0x0000	0xffff	0xffff	
Ra Table	95	R_a3x	2	xCell3 R_a 0	I2	0	32767	160	2 [~] 10ohm
Ra Table	95	R_a3x	4	xCell3 R_a 1	I2	0	32767	166	2 [~] 10ohm
Ra Table	95	R_a3x	6	xCell3 R_a 2	I2	0	32767	153	2 [~] 10ohm
Ra Table	95	R_a3x	8	xCell3 R_a 3	I2	0	32767	151	2 [~] 10ohm
Ra Table	95	R_a3x	10	xCell3 R_a 4	I2	0	32767	145	2 [~] 10ohm
Ra Table	95	R_a3x	12	xCell3 R_a 5	I2	0	32767	152	2 [~] 10ohm
Ra Table	95	R_a3x	14	xCell3 R_a 6	I2	0	32767	176	2 [~] 10ohm
Ra Table	95	R_a3x	16	xCell3 R_a 7	I2	0	32767	204	2 [~] 10ohm
Ra Table	95	R_a3x	18	xCell3 R_a 8	I2	0	32767	222	2 [~] 10ohm
Ra Table	95	R_a3x	20	xCell3 R_a 9	I2	0	32767	254	2 [~] 10ohm
Ra Table	95	R_a3x	22	xCell3 R_a 10	I2	0	32767	315	2 [~] 10ohm
Ra Table	95	R_a3x	24	xCell3 R_a 11	I2	0	32767	437	2 [~] 10ohm
Ra Table	95	R_a3x	26	xCell3 R_a 12	I2	0	32767	651	2 [~] 10ohm
Ra Table	95	R_a3x	28	xCell3 R_a 13	I2	0	32767	1001	2 [~] 10ohm
Ra Table	95	R_a3x	30	xCell3 R_a 14	I2	0	32767	1458	2 [~] 10ohm
PF Status	96	Device Status Data	0	PF Flags 1	H2	0x0000	0x4dff	0x0000	
PF Status	96	Device Status Data	28	PF Flags 2	H2	0x0000	0x0dff	0x0000	
Calibration	104	Data	0	CC Gain	F4	0.1	4	0.9419	
Calibration	104	Data	4	CC Delta	F4	29826	1193046	280932.625	
Calibration	104	Data	8	Ref Voltage	I2	0	65536	24500	50uV
Calibration	104	Data	12	AFE Pack Gain	I2	0	65536	22050	μV/cnt
Calibration	104	Data	14	CC Offset	I2	-32768	32767	-1667	
Calibration	104	Data	16	Board Offset	I2	-32768	32767	0	
Calibration	104	Data	18	Int Temp Offset	I1	-128	127	0	
Calibration	104	Data	19	Ext1 Temp Offset	I1	-128	127	0	
Calibration	104	Data	20	Ext2 Temp Offset	I1	-128	127	0	
Calibration	105	Config	0	CC Current	I2	0	65535	3000	mA
Calibration	105	Config	2	Voltage Signal	I2	0	65535	16800	mV
Calibration	105	Config	4	Temp Signal	I2	0	65535	2980	0.1K
Calibration	105	Config	6	CC Offset Time	U2	0	65535	250	mSec
Calibration	105	Config	8	ADC Offset Time	U2	0	65535	32	mSec
Calibration	105	Config	10	CC Gain Time	U2	0	65535	250	mSec
Calibration	105	Config	12	Voltage Time	U2	0	65535	1984	mSec
Calibration	105	Config	14	Temperature Time	U2	0	65535	32	mSec
Calibration	105	Config	17	Cal Mode Timeout	U2	0	65535	38400	Sec/128
Calibration	106	Temp Model	0	Ext Coef 1	I2	-32768	32767	-28285	Sec
Calibration	106	Temp Model	2	Ext Coef 2	I2	-32768	32767	20848	Sec
Calibration	106	Temp Model	4	Ext Coef 3	I2	-32768	32767	-7537	Sec
Calibration	106	Temp Model	6	Ext Coef 4	I2	-32768	32767	4012	Sec
Calibration	106	Temp Model	8	Ext Min AD	I2	-32768	32767	0	Sec
Calibration	106	Temp Model	10	Ext Max Temp	I2	-32768	32767	4012	Sec
Calibration	106	Temp Model	12	Int Coef 1	I2	-32768	32767	0	Sec
Calibration	106	Temp Model	14	Int Coef 2	I2	-32768	32767	0	Sec
Calibration	106	Temp Model	16	Int Coef 3	I2	-32768	32767	-11136	Sec

Table 3. DATAFLASH VALUES (continued)

Class	Subclass ID	Subclass	Offset	Name	Data Type	Min Value	Max Value	Default Value	Units
Calibration	106	Temp Model	18	Int Coef 4	I2	-32768	32767	5754	Sec
Calibration	106	Temp Model	20	Int Min AD	I2	-32768	32767	0	Sec
Calibration	106	Temp Model	22	Int Max Temp	I2	-32768	32767	5754	Sec
Calibration	107	Current	0	Filter	U1	0	255	239	
Calibration	107	Current	1	Deadband	U1	0	255	3	mA
Calibration	107	Current	2	CC Deadband	U1	0	255	34	294 nV

Application Schematic

The application schematic is on the following page.

PACKAGING INFORMATION

Orderable Device	Status ⁽¹⁾	Package Type	Package Drawing	Pins	Package Qty	Eco Plan ⁽²⁾	Lead/Ball Finish	MSL Peak Temp ⁽³⁾
BQ20Z70PW-V110	NRND	TSSOP	PW	20	70	Green (RoHS & no Sb/Br)	CU NIPDAU	Level-1-260C-UNLIM
BQ20Z70PW-V110G4	NRND	TSSOP	PW	20	70	Green (RoHS & no Sb/Br)	CU NIPDAU	Level-1-260C-UNLIM
BQ20Z70PWR-V110	NRND	TSSOP	PW	20	2000	Green (RoHS & no Sb/Br)	CU NIPDAU	Level-1-260C-UNLIM
BQ20Z70PWR-V110G4	NRND	TSSOP	PW	20	2000	Green (RoHS & no Sb/Br)	CU NIPDAU	Level-1-260C-UNLIM

⁽¹⁾ The marketing status values are defined as follows:

ACTIVE: Product device recommended for new designs.

LIFEBUY: TI has announced that the device will be discontinued, and a lifetime-buy period is in effect.

NRND: Not recommended for new designs. Device is in production to support existing customers, but TI does not recommend using this part in a new design.

PREVIEW: Device has been announced but is not in production. Samples may or may not be available.

OBSOLETE: TI has discontinued the production of the device.

⁽²⁾ Eco Plan - The planned eco-friendly classification: Pb-Free (RoHS), Pb-Free (RoHS Exempt), or Green (RoHS & no Sb/Br) - please check <http://www.ti.com/productcontent> for the latest availability information and additional product content details.

TBD: The Pb-Free/Green conversion plan has not been defined.

Pb-Free (RoHS): TI's terms "Lead-Free" or "Pb-Free" mean semiconductor products that are compatible with the current RoHS requirements for all 6 substances, including the requirement that lead not exceed 0.1% by weight in homogeneous materials. Where designed to be soldered at high temperatures, TI Pb-Free products are suitable for use in specified lead-free processes.

Pb-Free (RoHS Exempt): This component has a RoHS exemption for either 1) lead-based flip-chip solder bumps used between the die and package, or 2) lead-based die adhesive used between the die and leadframe. The component is otherwise considered Pb-Free (RoHS compatible) as defined above.

Green (RoHS & no Sb/Br): TI defines "Green" to mean Pb-Free (RoHS compatible), and free of Bromine (Br) and Antimony (Sb) based flame retardants (Br or Sb do not exceed 0.1% by weight in homogeneous material)

⁽³⁾ MSL, Peak Temp. -- The Moisture Sensitivity Level rating according to the JEDEC industry standard classifications, and peak solder temperature.

Important Information and Disclaimer: The information provided on this page represents TI's knowledge and belief as of the date that it is provided. TI bases its knowledge and belief on information provided by third parties, and makes no representation or warranty as to the accuracy of such information. Efforts are underway to better integrate information from third parties. TI has taken and continues to take reasonable steps to provide representative and accurate information but may not have conducted destructive testing or chemical analysis on incoming materials and chemicals. TI and TI suppliers consider certain information to be proprietary, and thus CAS numbers and other limited information may not be available for release.

In no event shall TI's liability arising out of such information exceed the total purchase price of the TI part(s) at issue in this document sold by TI to Customer on an annual basis.

PW (R-PDSO-G20)

PLASTIC SMALL OUTLINE



4040064-5/G 02/11

- NOTES:
- A. All linear dimensions are in millimeters. Dimensioning and tolerancing per ASME Y14.5M-1994.
 - B. This drawing is subject to change without notice.
 - C. Body length does not include mold flash, protrusions, or gate burrs. Mold flash, protrusions, or gate burrs shall not exceed 0,15 each side.
 - D. Body width does not include interlead flash. Interlead flash shall not exceed 0,25 each side.
 - E. Falls within JEDEC MO-153

PW (R-PDSO-G20)

PLASTIC SMALL OUTLINE

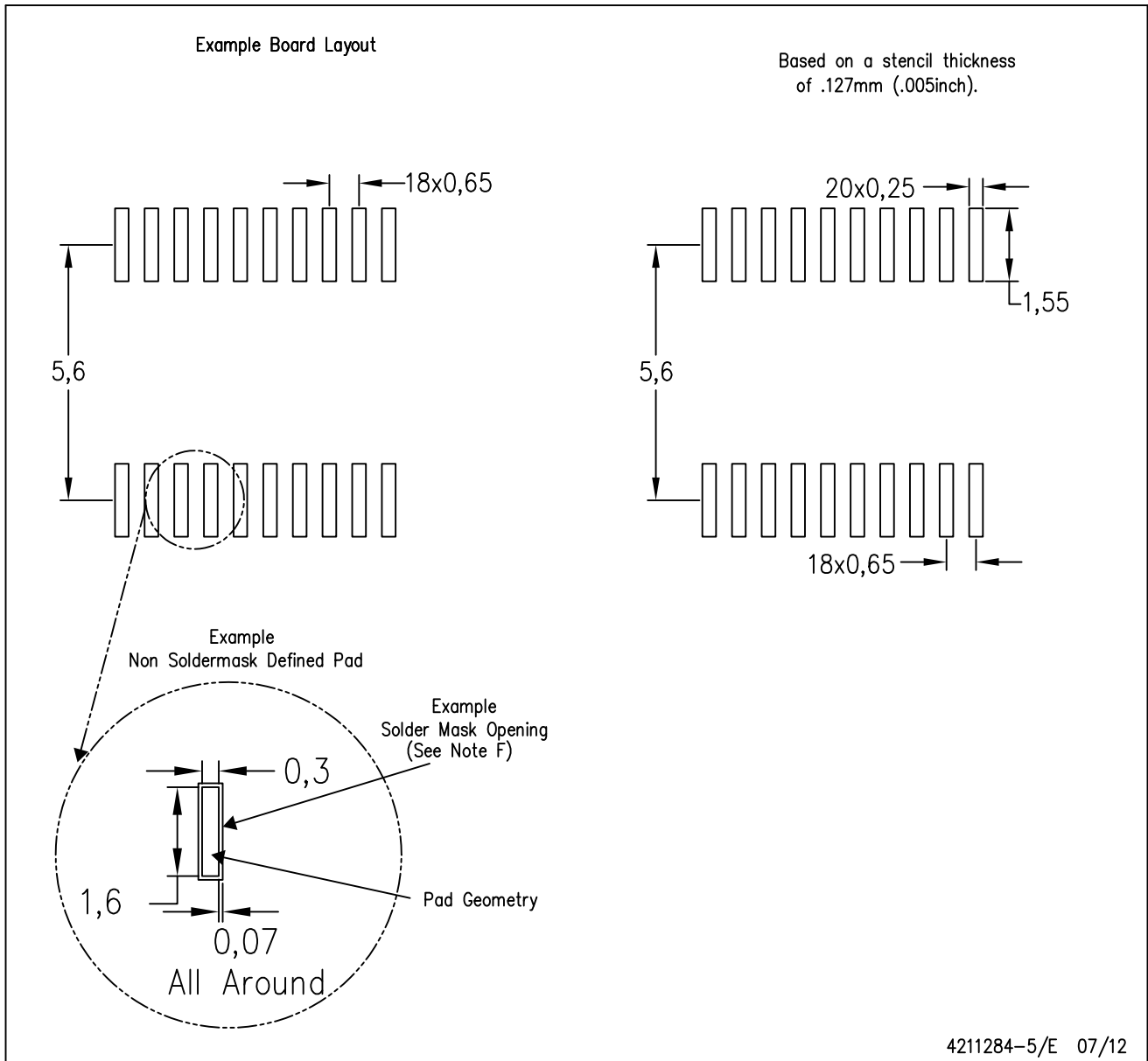

- NOTES:
- A. All linear dimensions are in millimeters.
 - B. This drawing is subject to change without notice.
 - C. Publication IPC-7351 is recommended for alternate design.
 - D. Laser cutting apertures with trapezoidal walls and also rounding corners will offer better paste release. Customers should contact their board assembly site for stencil design recommendations. Refer to IPC-7525 for other stencil recommendations.
 - E. Customers should contact their board fabrication site for solder mask tolerances between and around signal pads.

IMPORTANT NOTICE

Texas Instruments Incorporated and its subsidiaries (TI) reserve the right to make corrections, modifications, enhancements, improvements, and other changes to its products and services at any time and to discontinue any product or service without notice. Customers should obtain the latest relevant information before placing orders and should verify that such information is current and complete. All products are sold subject to TI's terms and conditions of sale supplied at the time of order acknowledgment.

TI warrants performance of its hardware products to the specifications applicable at the time of sale in accordance with TI's standard warranty. Testing and other quality control techniques are used to the extent TI deems necessary to support this warranty. Except where mandated by government requirements, testing of all parameters of each product is not necessarily performed.

TI assumes no liability for applications assistance or customer product design. Customers are responsible for their products and applications using TI components. To minimize the risks associated with customer products and applications, customers should provide adequate design and operating safeguards.

TI does not warrant or represent that any license, either express or implied, is granted under any TI patent right, copyright, mask work right, or other TI intellectual property right relating to any combination, machine, or process in which TI products or services are used. Information published by TI regarding third-party products or services does not constitute a license from TI to use such products or services or a warranty or endorsement thereof. Use of such information may require a license from a third party under the patents or other intellectual property of the third party, or a license from TI under the patents or other intellectual property of TI.

Reproduction of TI information in TI data books or data sheets is permissible only if reproduction is without alteration and is accompanied by all associated warranties, conditions, limitations, and notices. Reproduction of this information with alteration is an unfair and deceptive business practice. TI is not responsible or liable for such altered documentation. Information of third parties may be subject to additional restrictions.

Resale of TI products or services with statements different from or beyond the parameters stated by TI for that product or service voids all express and any implied warranties for the associated TI product or service and is an unfair and deceptive business practice. TI is not responsible or liable for any such statements.

TI products are not authorized for use in safety-critical applications (such as life support) where a failure of the TI product would reasonably be expected to cause severe personal injury or death, unless officers of the parties have executed an agreement specifically governing such use. Buyers represent that they have all necessary expertise in the safety and regulatory ramifications of their applications, and acknowledge and agree that they are solely responsible for all legal, regulatory and safety-related requirements concerning their products and any use of TI products in such safety-critical applications, notwithstanding any applications-related information or support that may be provided by TI. Further, Buyers must fully indemnify TI and its representatives against any damages arising out of the use of TI products in such safety-critical applications.

TI products are neither designed nor intended for use in military/aerospace applications or environments unless the TI products are specifically designated by TI as military-grade or "enhanced plastic." Only products designated by TI as military-grade meet military specifications. Buyers acknowledge and agree that any such use of TI products which TI has not designated as military-grade is solely at the Buyer's risk, and that they are solely responsible for compliance with all legal and regulatory requirements in connection with such use.

TI products are neither designed nor intended for use in automotive applications or environments unless the specific TI products are designated by TI as compliant with ISO/TS 16949 requirements. Buyers acknowledge and agree that, if they use any non-designated products in automotive applications, TI will not be responsible for any failure to meet such requirements.

Following are URLs where you can obtain information on other Texas Instruments products and application solutions:

Products

Audio	www.ti.com/audio
Amplifiers	amplifier.ti.com
Data Converters	dataconverter.ti.com
DLP® Products	www.dlp.com
DSP	dsp.ti.com
Clocks and Timers	www.ti.com/clocks
Interface	interface.ti.com
Logic	logic.ti.com
Power Mgmt	power.ti.com
Microcontrollers	microcontroller.ti.com
RFID	www.ti-rfid.com
OMAP Mobile Processors	www.ti.com/omap
Wireless Connectivity	www.ti.com/wirelessconnectivity

Applications

Automotive and Transportation	www.ti.com/automotive
Communications and Telecom	www.ti.com/communications
Computers and Peripherals	www.ti.com/computers
Consumer Electronics	www.ti.com/consumer-apps
Energy and Lighting	www.ti.com/energy
Industrial	www.ti.com/industrial
Medical	www.ti.com/medical
Security	www.ti.com/security
Space, Avionics and Defense	www.ti.com/space-avionics-defense
Video and Imaging	www.ti.com/video

TI E2E Community Home Page

e2e.ti.com

Mailing Address: Texas Instruments, Post Office Box 655303, Dallas, Texas 75265
Copyright © 2012, Texas Instruments Incorporated