

## Li-Ion Power Gauge™ Module

### Features

- Complete bq2050H Power Gauge solution for Li-Ion battery packs
- Battery information available over a single-wire (HDQ) bidirectional serial port
- Control signals to enhance pack protection
- Battery state-of-charge monitoring for 2- to 5-cell series applications
- On-board regulator allows direct connection to the battery
- “L” version includes push-button activated LEDs to display state-of-charge information
- Nominal capacity pre-configured
- Compact size for battery pack integration

### General Description

The bq2150H Power Gauge Module provides a complete and compact solution for capacity monitoring of Li-Ion battery packs. Designed for battery pack integration, the bq2150 incorporates a bq2150H Gas Gauge IC, a current sense resistor, and all other components necessary to accurately monitor and display the capacity of 2 to 5 series cells.

The bq2150L includes five LEDs to display remaining capacity in 20% increments of the learned capacity. The LEDs are activated with the onboard push-button switch.

Contacts are provided on the bq2150H for direct connection to the battery stack (BAT+, BAT-) and the serial communications port (HDQ). The RBI input provides backup power to the bq2150H in the event that the cells are removed or the battery is turned off. The bq2150H has a 1 $\mu$ F capacitor onboard connected to RBI to supply backup power for about an hour. In battery packs that use high-side FETs to control the charge/discharge of the Li-Ion cells, the RBI input can be wired to a single cell to provide prolonged data retention times. The SD input allows an external signal (active low) to turn the bq2050H IC off to minimize internal current consumption of the battery pack and maximize storage life of the pack in the system. When turned off, the bq2150H is non-functional, and the RBI power source maintains register information. Please refer to the bq2050H data sheet for the specifics on the operation of the Gas Gauge.

Unitrode configures the bq2150H based on the information requested in Table 1. The configuration defines the

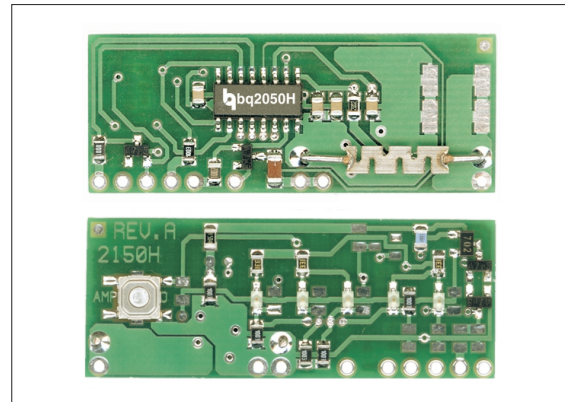

number of series cells, the nominal battery pack capacity, and the Li-Ion battery type (coke or graphite anode). Figure 1 shows how the module connects to the cells.

A module development kit is also available for the bq2150. The bq2150HB-KT or the bq2150HLB-KT includes one configured module and the following:

- 1) An EV2200-50H interface board that allows connection to the serial port of an AT-compatible computer.
- 2) Menu-driven software to display charge/discharge activity and to allow user interface to the bq2150H from any standard Windows 3.1x or 95 PC.

### Pin Descriptions

<b>P1</b>	<b>HDQ/Serial Communications port</b>
<b>P2</b>	<b>PSTAT/Protector status input</b>
<b>P3</b>	<b>BAT+/Battery positive/pack positive</b>
<b>P4</b>	<b>SD/Shutdown</b>
<b>P5</b>	<b>RBI/Register backup input</b>
<b>P6</b>	<b>GND/Ground</b>
<b>P7</b>	<b>PACK-/Pack negative</b>
<b>P8</b>	<b>BAT-/Battery negative</b>
<b>P9</b>	<b>CFC/Charge FET control output</b>

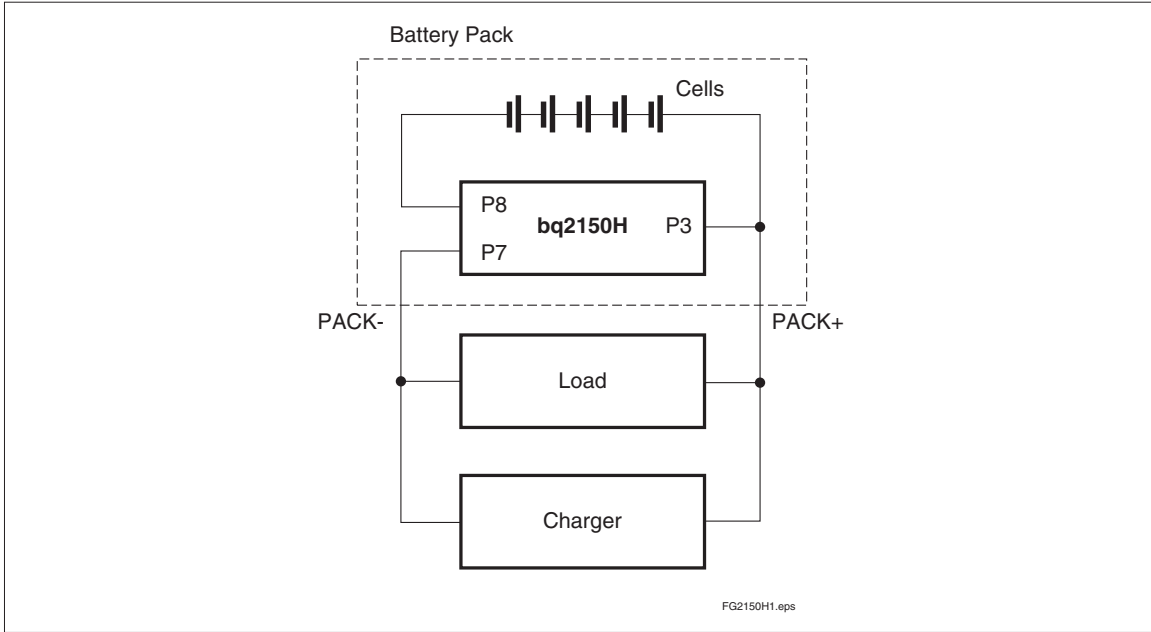

**Figure 1. Module Connection Diagram**

**Table 1. bq2150H Module Configuration**

Customer Name: \_\_\_\_\_

Contact: \_\_\_\_\_ Phone: \_\_\_\_\_

Address: \_\_\_\_\_

\_\_\_\_\_

Sales Contact: \_\_\_\_\_ Phone: \_\_\_\_\_

Number of series battery cells (2-5) \_\_\_\_\_

Coke or graphite cell anode \_\_\_\_\_

Battery pack capacity (mAh) \_\_\_\_\_

Discharge rate into load (A) min. \_\_\_\_\_ avg. \_\_\_\_\_ max. \_\_\_\_\_

Charge rate \_\_\_\_\_

Self-discharge compensation (Y/N) \_\_\_\_\_

LEDs and switch (Y/N) \_\_\_\_\_

FAE Approval: \_\_\_\_\_ Date: \_\_\_\_\_

### bq2150H Schematic

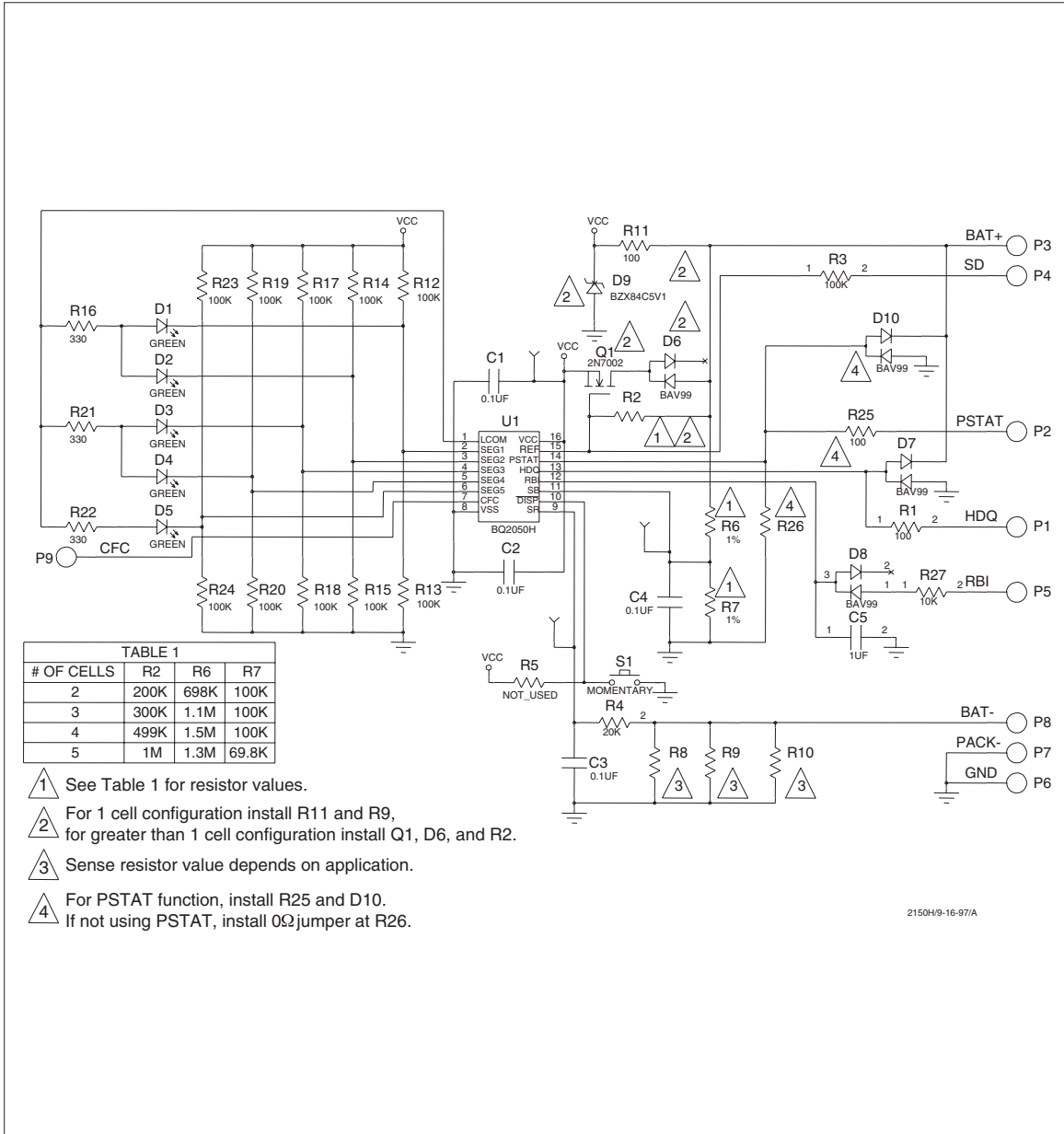

# bq2150H Preliminary

## bq2150H Board

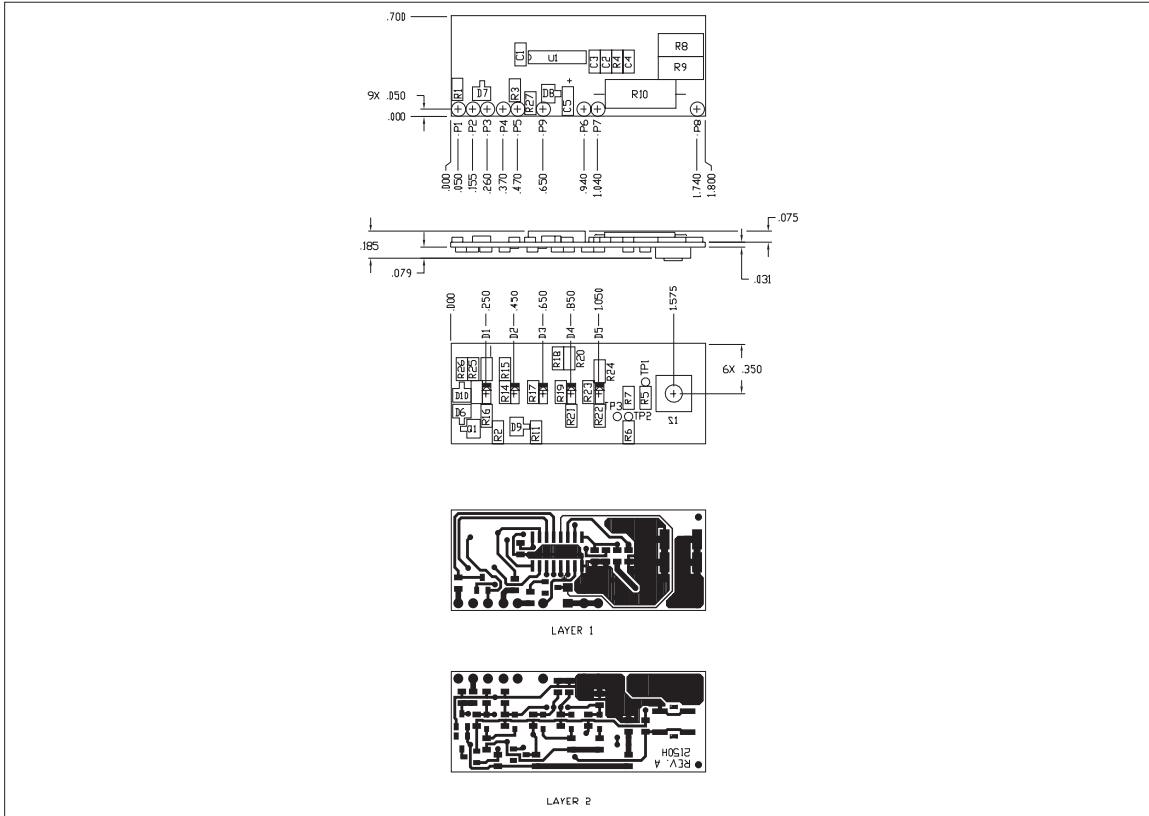

## Ordering Information

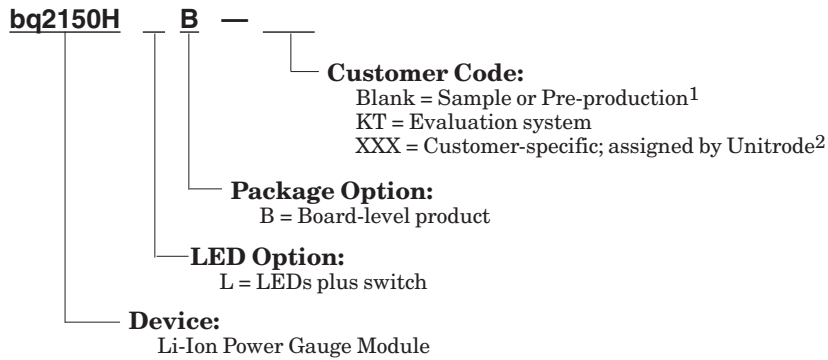

- Notes:**
1. Requires configuration sheet (Table 1)
  2. Example production part number: bq2150HLB-001

## IMPORTANT NOTICE

Texas Instruments and its subsidiaries (TI) reserve the right to make changes to their products or to discontinue any product or service without notice, and advise customers to obtain the latest version of relevant information to verify, before placing orders, that information being relied on is current and complete. All products are sold subject to the terms and conditions of sale supplied at the time of order acknowledgement, including those pertaining to warranty, patent infringement, and limitation of liability.

TI warrants performance of its semiconductor products to the specifications applicable at the time of sale in accordance with TI's standard warranty. Testing and other quality control techniques are utilized to the extent TI deems necessary to support this warranty. Specific testing of all parameters of each device is not necessarily performed, except those mandated by government requirements.

CERTAIN APPLICATIONS USING SEMICONDUCTOR PRODUCTS MAY INVOLVE POTENTIAL RISKS OF DEATH, PERSONAL INJURY, OR SEVERE PROPERTY OR ENVIRONMENTAL DAMAGE ("CRITICAL APPLICATIONS"). TI SEMICONDUCTOR PRODUCTS ARE NOT DESIGNED, AUTHORIZED, OR WARRANTED TO BE SUITABLE FOR USE IN LIFE-SUPPORT DEVICES OR SYSTEMS OR OTHER CRITICAL APPLICATIONS. INCLUSION OF TI PRODUCTS IN SUCH APPLICATIONS IS UNDERSTOOD TO BE FULLY AT THE CUSTOMER'S RISK.

In order to minimize risks associated with the customer's applications, adequate design and operating safeguards must be provided by the customer to minimize inherent or procedural hazards.

TI assumes no liability for applications assistance or customer product design. TI does not warrant or represent that any license, either express or implied, is granted under any patent right, copyright, mask work right, or other intellectual property right of TI covering or relating to any combination, machine, or process in which such semiconductor products or services might be or are used. TI's publication of information regarding any third party's products or services does not constitute TI's approval, warranty or endorsement thereof.