

Tablet PC and Netbook 2-Series Cell Li-Ion Battery Gas Gauge and Protection

 Check for Samples: [bq28400](#)

FEATURES

- Fully Integrated Gas Gauge and Analog Monitoring with Protection in a Single Package
- 2-Series Cell Li-Ion or Li-Polymer Battery Packs
- Flexible Memory Architecture with Integrated Flash Memory
- Zero-Volt and Pre-Charge Mode
- Full Array of Programmable Protection:
 - OV (Overvoltage)
 - UV (Undervoltage)
 - SC (Short Circuit)
 - OT (Overtemperature)
 - CIM (Cell Imbalance)
- Accurate CEDV Gauging Algorithm with Self Discharge Compensation
- High Accuracy Analog Interface with Two Independent ADCs:
 - High Resolution 16-Bit Integrator for Coulomb Counting
 - 16-Bit Delta-Sigma ADC with a 16-Channel Multiplexer for Voltage, Current, and Temperature
- High Side Protection FET Drive
- Fully Integrated Internal Clock Synthesizer with No External Components Required
- Two-Wire SMBus v1.1 Compliant Communications

- Reduced Power Modes (Typical Battery Pack Operating Range Conditions)
 - Low Power
 - Shutdown
- 20-Pin TSSOP Package (RoHS-Compliant)
- JEITA/Enhanced Charging
- Supports SHA-1 Authentication Responder

APPLICATIONS

- Tablet PCs
- Slate PCs
- Netbooks/Notebooks
- Smartbooks

DESCRIPTION

The bq28400 device is a fully integrated gas gauge and analog monitoring management solution that provides protection and control for 2-series cell Li-Ion battery packs in a single TSSOP package.

Implementing the optimum balance of quick response analog hardware-based monitoring and control along with an integrated fast CPU provides the ideal pack-based or in-system Li-Ion battery solution. The bq28400 also provides flexible user programmable settings stored in flash memory for control of critical system parameters such as overcurrent, short circuit, under/overvoltage, and over/undertemperature conditions.

The bq28400 communicates with the system host via a two-wire SMBus 1.1 compatible interface, providing high-accuracy reporting and control of battery pack operation. The FET drive and TSSOP package enable a lower cost and small footprint solution along with a simple layout and routing on narrow pack PCBs.

AVAILABLE OPTIONS

T _A	PACKAGE ⁽¹⁾	
	20-PIN TSSOP (PW) Tube	20-PIN TSSOP (PW) Tape and Reel
–40°C to 85°C	bq28400PW ⁽²⁾	bq28400PWR ⁽³⁾

(1) For the most current package and ordering information, see the Package Option Addendum at the end of this document, or see the TI website at www.ti.com.

(2) A single tube quantity is 50 units.

(3) A single reel quantity is 2000 units.



Please be aware that an important notice concerning availability, standard warranty, and use in critical applications of Texas Instruments semiconductor products and disclaimers thereto appears at the end of this data sheet.



These devices have limited built-in ESD protection. The leads should be shorted together or the device placed in conductive foam during storage or handling to prevent electrostatic damage to the MOS gates.

BLOCK DIAGRAM and TYPICAL IMPLEMENTATION

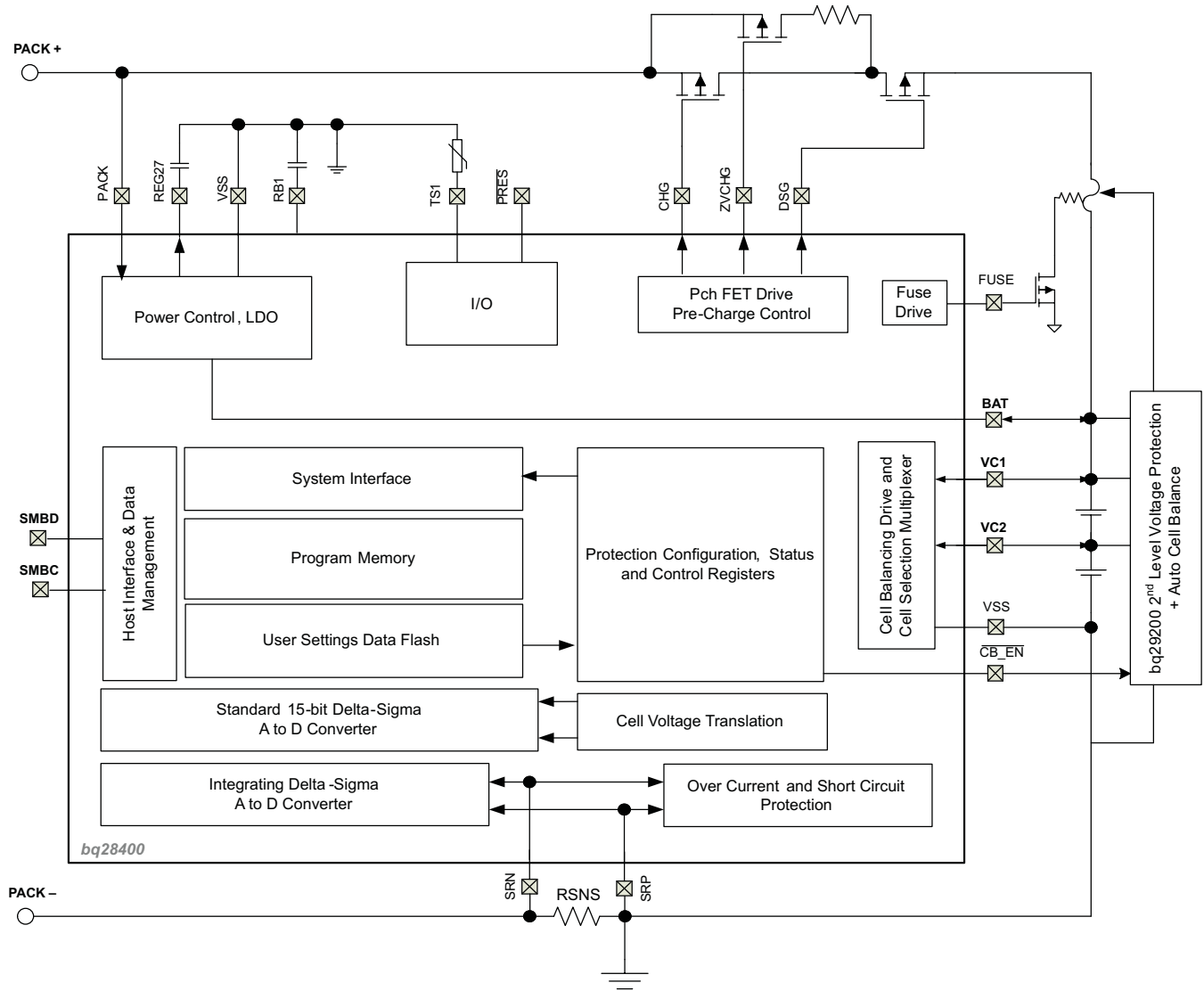

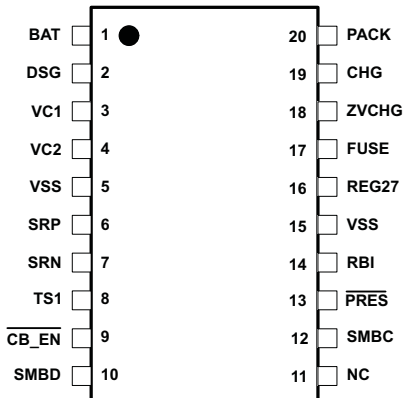
**bq28400
PW PACKAGE
(TOP VIEW)**

PIN FUNCTIONS

PIN NAME	PIN NUMBER	TYPE ⁽¹⁾	DESCRIPTION
BAT	1	P	Alternate supply input
DSG	2	O	P-channel discharge FET gate drive
VC1	3	AI	Sense input for the most positive cell. Also external cell balancing drive output for the most positive cell
VC2	4	AI	Sense input for the lowest cell. Also external cell balancing drive output for the lowest cell
VSS	5	P	Device ground
SRP	6	AI	Differential Coulomb Counter input or SRP oversampled ADC input
SRN	7	AI	Differential Coulomb Counter input or SRN oversampled ADC input
TS1	8	I	Thermistor 1 input. Connect NTC from this pin to VSS pin
$\overline{\text{CB_EN}}$	9	O	Output signal to control cell balancing
SMBD	10	I/OD	SBS data
NC	11	—	No connection, leave floating
SMBC	12	I/OD	SBS clock
$\overline{\text{PRES}}$	13	I	System present
RBI	14	P	RAM backup pin to provide backup potential to the internal DATA RAM if power is momentarily lost, by using a capacitor attached between RBI and VSS
VSS	15	P	Device ground
REG27	16	P	2.7-V regulator. Connect a capacitor between REG27 and VSS
FUSE	17	O	Push-pull fuse circuit drive
ZVCHG	18	O	P-channel precharge FET gate drive
CHG	19	O	P-channel charge FET gate drive
PACK	20	P	Alternate supply input

(1) P = Power Connection, O = Digital Output, AI = Analog Input, I = Digital Input, I/OD = Digital Input/Output

THERMAL INFORMATION

THERMAL METRIC ⁽¹⁾		bq28400	UNITS
		PW	
		20 PINS	
θ_{JA}	Junction-to-ambient thermal resistance ⁽²⁾	91.7	°C/W
$\theta_{JC(top)}$	Junction-to-case(top) thermal resistance ⁽³⁾	20.4	
θ_{JB}	Junction-to-board thermal resistance ⁽⁴⁾	45.6	
ψ_{JT}	Junction-to-top characterization parameter ⁽⁵⁾	0.5	
ψ_{JB}	Junction-to-board characterization parameter ⁽⁶⁾	43.3	
$\theta_{JC(bottom)}$	Junction-to-case(bottom) thermal resistance ⁽⁷⁾	n/a	

- (1) For more information about traditional and new thermal metrics, see the *IC Package Thermal Metrics* application report, [SPRA953](#).
- (2) The junction-to-ambient thermal resistance under natural convection is obtained in a simulation on a JEDEC-standard, high-K board, as specified in JESD51-7, in an environment described in JESD51-2a.
- (3) The junction-to-case (top) thermal resistance is obtained by simulating a cold plate test on the package top. No specific JEDEC-standard test exists, but a close description can be found in the ANSI SEMI standard G30-88.
- (4) The junction-to-board thermal resistance is obtained by simulating in an environment with a ring cold plate fixture to control the PCB temperature, as described in JESD51-8.
- (5) The junction-to-top characterization parameter, ψ_{JT} , estimates the junction temperature of a device in a real system and is extracted from the simulation data for obtaining θ_{JA} , using a procedure described in JESD51-2a (sections 6 and 7).
- (6) The junction-to-board characterization parameter, ψ_{JB} , estimates the junction temperature of a device in a real system and is extracted from the simulation data for obtaining θ_{JA} , using a procedure described in JESD51-2a (sections 6 and 7).
- (7) The junction-to-case (bottom) thermal resistance is obtained by simulating a cold plate test on the exposed (power) pad. No specific JEDEC standard test exists, but a close description can be found in the ANSI SEMI standard G30-88.

ABSOLUTE MAXIMUM RATINGS

over operating free-air temperature (unless otherwise noted)⁽¹⁾

		Value/Unit
Supply voltage range, V_{MAX}	PACK w.r.t. V_{SS}	-0.3 to 34 V
Input voltage range, V_{IN}	VC1, BAT	$V_{VC2} - 0.3$ to $V_{VC2} + 8.5$ or 34 V, whichever is lower
	VC2	$V_{VSRP} - 0.3$ to $V_{VSRP} + 8.5$ V
	SRP, SRN	-0.3 to V_{REG27}
	General Purpose open-drain I/O pins: SMBD, SMBC	$V_{SS} - 0.3$ V to 6 V
	General Purpose push-pull I/O pins: TS1, \overline{PRES} , $\overline{CB_EN}$	-0.3 V to $V_{REG27} + 0.3$ V
	Input voltage range to all other pins, V_{IN} relative to V_{SS}	-0.3 V to $V_{REG27} + 0.3$ V
	DSG, CHG, ZVCHG	-0.3 to BAT
	FUSE	-0.3 to [BAT or PACK] (whichever is lower)
	RBI, REG27	-0.3 to 2.75 V
Maximum Operational VSS current, I_{SS}		50 mA
Ambient Temperature, T_A		-20 to 110°C
Storage temperature range, T_{STG}		-65 to 150°C
ESD Human Body Model ⁽²⁾	All pins except VC1 and VC2	2 kV
	VC1 and VC2	1 kV
ESD Machine Model	All pins	200 V

- (1) Stresses beyond those listed under absolute maximum ratings may cause permanent damage to the device. These are stress ratings only, and functional operation of the device at these or any other conditions beyond those indicated under recommended operating conditions is not implied. Exposure to absolute-maximum-rated conditions for extended periods may affect device reliability.
- (2) The human body model is a 100-pF capacitor discharged through a 1.5-k Ω resistor into each pin.

RECOMMENDED OPERATING CONDITIONS

over operating free-air temperature range (unless otherwise noted)

		PIN	MIN	NOM	MAX	UNIT
Supply voltage		PACK			$V_{BAT} + 5$	V
		BAT	3.8		$V_{VC2} + 5$	
$V_{(STARTUP)}$	Minimum startup voltage	Start up voltage at PACK		5.2	5.5	V
V_{IN}	Input Voltage Range	VC1, BAT	V_{VC2}		$V_{VC2} + 5$	V
		VC2	V_{VSRP}		$V_{VSRP} + 5$	V
		VC1 – VC2	0		5	V
		PACK			18.75	V
		SRP to SRN	-0.3		1	V
$C_{(REG27)}$	External 2.7 V REG capacitor		1			μ F
T_{OPR}	Operating temperature		-20		85	$^{\circ}$ C

ELECTRICAL CHARACTERISTICS

 Typical values stated where $T_A = 25^{\circ}$ C and $V_{BAT} = V_{PACK} = 7.2$ V, Min/Max values stated where $T_A = -20^{\circ}$ C to 85° C and $V_{BAT} = V_{PACK} = 3.8$ V to 18.75 V over operating free-air temperature range (unless otherwise noted)

PARAMETER		TEST CONDITION ⁽¹⁾	MIN	TYP	MAX	UNIT
General Purpose I/O						
V_{IH}	High-level input voltage	SMBD, SMBC, \overline{PRES}	2			V
V_{IL}	Low-level input voltage	SMBD, SMBC, \overline{PRES}			0.8	V
V_{OH}	Output voltage high	\overline{PRES} , $I_L = -0.5$ mA	$V_{REG27} - 0.5$			V
$V_{OH(FUSE)}$	High level Fuse output	$V_{BAT} = 3.8$ V to 9 V, $C_L = 1$ nF	3	$V_{BAT} - 0.3$	8.6	V
		$V_{BAT} = 9$ V to 10 V, $C_L = 1$ nF	7.5	8	9	
$t_{R(FUSE)}$	FUSE output rise time	$C_L = 1$ nF, $V_{OH(FUSE)} = 0$ V to 5 V			10	μ s
$I_{O(FUSE)}$	FUSE output current	FUSE active	-3			mA
$Z_{O(FUSE)}$	FUSE output impedance			2	6	k Ω
V_{FUSE_DET}	FUSE Detect Input Voltage		0.8	2	3.2	V
V_{OL}	Low-level output voltage	SMBD, SMBC, TS1, $I_L = 7$ mA			0.4	V
C_{IN}	Input capacitance			5		pF
$I_{(VOUT)}$	VOUT source currents	V_O active, $V_O = V_{REG27} - 0.6$ V	-3			mA
$I_{LKG(VOUT)}$	VOUT leakage current	V_O inactive	-0.2		0.2	μ A
I_{LKG}	Input leakage current	SMBD, SMBC, \overline{PRES} , TS1			1	μ A
$R_{PD(SMBx)}$	SMBD and SMBC, pull-down resistor	$T_A = -20^{\circ}$ C to 100° C	600	950	1300	k Ω
R_{PAD}	Pad resistance	TS1		87	110	Ω
Supply Current						
I_{CC}	Normal Mode	No flash memory write, No I/O activity		400		μ A
I_{LPM}	Low-Power Mode	CPU=HALT CHG=DSG=PCHG=OFF LDO ON but no load, no communication, BAT = 7.2 V		55		μ A
$I_{SHUTDOWN}$	Shutdown Mode	$T_A = -20^{\circ}$ C to 110° C		0.5	1	μ A
REG27 Power On Reset						
$V_{REG27IT-}$	Negative-going voltage input, at REG27		2.22	2.29	2.34	V
$V_{REG27IT+}$	Positive-going voltage input, at REG27		2.25	2.5	2.6	V
Flash						
	Data retention		10			Years

(1) By default: SMBus has internal pull-down.

ELECTRICAL CHARACTERISTICS (continued)

Typical values stated where $T_A = 25^\circ\text{C}$ and $V_{\text{BAT}} = V_{\text{PACK}} = 7.2\text{ V}$, Min/Max values stated where $T_A = -20^\circ\text{C}$ to 85°C and $V_{\text{BAT}} = V_{\text{PACK}} = 3.8\text{ V}$ to 18.75 V over operating free-air temperature range (unless otherwise noted)

PARAMETER		TEST CONDITION ⁽¹⁾	MIN	TYP	MAX	UNIT	
	Flash programming write-cycles		20k			Cycles	
t_{ROWPROG}	Row programming time				2	ms	
$t_{\text{MASSERASE}}$	Mass-erase time				250		
$t_{\text{PAGEERASE}}$	Page-erase time				25		
$I_{\text{CC(PROG)}}$	Flash-write supply current			4	6	mA	
$I_{\text{CC(ERASE)}}$	Flash-erase supply current	$T_A = -40^\circ\text{C}$ to 0°C		8	22		
		$T_A = 0^\circ\text{C}$ to 85°C		3	15		
RAM Backup							
$I_{\text{(RBI)}}$	RBI data-retention input current	$V_{\text{RBI}} > V_{\text{(RBI)MIN}}$, $V_{\text{REG27}} < V_{\text{REG27IT-}}$, $T_A = 70^\circ\text{C}$ to 110°C		20	1500	nA	
		$V_{\text{RBI}} > V_{\text{(RBI)MIN}}$, $V_{\text{REG27}} < V_{\text{REG27IT-}}$, $T_A = -20^\circ\text{C}$ to 70°C			500		
$V_{\text{(RBI)}}$	RBI data-retention voltage ⁽²⁾		1			V	
Internal LDO							
V_{REG}	Regulator output voltage	$I_{\text{REG27}} = 10\text{ mA}$, $T_A = -20^\circ\text{C}$ to 85°C	2.5	2.7	2.75	V	
I_{REG}	Regulator Output Current	PACK and BAT $\leq 4.5\text{ V}$, $T_A = -20^\circ\text{C}$ to 110°C	3			mA	
		$4.5\text{ V} < \text{PACK}$ and $\text{BAT} \leq 6.8\text{ V}$	10				
		$6.8\text{ V} < \text{PACK}$ and $\text{BAT} \leq 18.75\text{ V}$, $T_A = -20^\circ\text{C}$ to 70°C	16				
$\Delta V_{\text{(REGTEMP)}}$	Regulator output change with temperature	$I_{\text{REG}} = 10\text{ mA}$, $T_A = -20^\circ\text{C}$ to 85°C	$\pm 0.5\%$				
$\Delta V_{\text{(REGLINE)}}$	Line regulation	$I_{\text{REG}} = 10\text{ mA}$	± 2			mV	
$\Delta V_{\text{(REGLOAD)}}$	Load regulation	$I_{\text{REG}} = 0.2$ to 10 mA	± 20			mV	
$I_{\text{(REGMAX)}}$	Current limit		25			50	mA

(2) Specified by design. Not production tested.

ELECTRICAL CHARACTERISTICS (continued)

Typical values stated where $T_A = 25^\circ\text{C}$ and $V_{\text{BAT}} = V_{\text{PACK}} = 7.2\text{ V}$, Min/Max values stated where $T_A = -20^\circ\text{C}$ to 85°C and $V_{\text{BAT}} = V_{\text{PACK}} = 3.8\text{ V}$ to 18.75 V over operating free-air temperature range (unless otherwise noted)

PARAMETER		TEST CONDITION ⁽¹⁾	MIN	TYP	MAX	UNIT
SRx Wake from Sleep						
$V_{\text{WAKE_ACR}}$	Accuracy of V_{WAKE}	$V_{\text{WAKE}} = 1.2\text{ mV}$	0.2	1.2	2	mV
		$V_{\text{WAKE}} = 2.4\text{ mV}$	0.4	2.4	3.6	
		$V_{\text{WAKE}} = 5\text{ mV}$	2	5	6.8	
		$V_{\text{WAKE}} = 10\text{ mV}$	5.3	10	13	
$V_{\text{WAKE_TCO}}$	Temperature drift of V_{WAKE} accuracy			0.5		$\%^\circ\text{C}$
t_{WAKE}	Time from application of current and wake of bq28400			0.2	1	ms
Coulomb Counter						
	Input voltage range		-0.20		0.25	V
	Conversion time	Single conversion		250		ms
	Effective resolution	Single conversion	15			Bits
	Integral nonlinearity	$T_A = -20$ to 85°C		± 0.007	± 0.034	$\% \text{FSR}$
	Offset error ⁽³⁾	$T_A = -20$ to 85°C		10		μV
	Offset error drift			0.3	0.5	$\mu\text{V}/^\circ\text{C}$
	Full-scale error ⁽⁴⁾		-0.8%	0.2%	0.8%	
	Full-scale error drift				150	PPM/ $^\circ\text{C}$
	Effective input resistance	ADC enabled	2.5			$\text{M}\Omega$
ADC						
	Input voltage range for TS1		-0.2		$0.8 \times V_{\text{REG27}}$	V
	Conversion time			31.5		ms
	Resolution (no missing codes)		16			Bits
	Effective resolution			15		Bits
	Integral nonlinearity	-0.1 V to $0.8 \times V_{\text{ref}}$			± 0.020	$\% \text{FSR}$
	Offset error ⁽⁵⁾			70	160	μV
	Offset error drift			25		$\mu\text{V}/^\circ\text{C}$
	Full-scale error	$V_{\text{IN}} = 1\text{ V}$	-0.8%	$\pm 0.2\%$	0.4%	
	Full-scale error drift				150	PPM/ $^\circ\text{C}$
	Effective input resistance		8			$\text{M}\Omega$
External Cell Balance Drive						
$R_{\text{BAL_drive}}$	Internal pull-down resistance for external cell balance	Cell balance ON for VC1, $\text{VCx} - \text{VCx} + 4\text{ V}$, where $x = 1$ to 2		3.7		k Ω
		Cell balance ON for VC2, $\text{VCx} - \text{VCx} + 4\text{ V}$, where $x = 1$ to 2		1.75		
Cell Voltage Monitor						
	CELL Voltage Measurement Accuracy	$T_A = -10^\circ\text{C}$ to 60°C		± 10	± 20	mV
		$T_A = -20^\circ\text{C}$ to 85°C		± 10	± 35	

(3) Post-Calibration Performance

(4) Uncalibrated performance. This gain error can be eliminated with external calibration.

(5) Channel to Channel Offset

ELECTRICAL CHARACTERISTICS (continued)

Typical values stated where $T_A = 25^\circ\text{C}$ and $V_{\text{BAT}} = V_{\text{PACK}} = 7.2\text{ V}$, Min/Max values stated where $T_A = -20^\circ\text{C}$ to 85°C and $V_{\text{BAT}} = V_{\text{PACK}} = 3.8\text{ V}$ to 18.75 V over operating free-air temperature range (unless otherwise noted)

PARAMETER		TEST CONDITION ⁽¹⁾	MIN	TYP	MAX	UNIT
Internal Temperature Sensor						
T_{INT}	Temperature sensor accuracy			±3%		°C
Thermistor Measurement Support						
R_{ERR}	Internal resistor drift			±230		PPM/°C
R	Internal resistor			18	20	kΩ
Internal Thermal Shutdown						
T_{MAX}	Maximum REG27 temperature ⁽⁶⁾		125		175	°C
T_{RECOVER}	Recovery hysteresis temperature ⁽⁶⁾			10		
Current Protection Thresholds						
$V_{\text{(OCD)}}$	OCD detection threshold voltage range, typical		50		200	mV
$\Delta V_{\text{(OCDT)}}$	OCD detection threshold voltage program step			10		mV
$V_{\text{(SCCT)}}$	SCC detection threshold voltage range, typical		-100		-300	mV
$\Delta V_{\text{(SCCT)}}$	SCC detection threshold voltage program step			-50		mV
$V_{\text{(SCDT)}}$	SCD detection threshold voltage range, typical		100		450	mV
$\Delta V_{\text{(SCDT)}}$	SCD detection threshold voltage program step			50		mV
$V_{\text{(OFFSET)}}$	SCD, SCC, and OCD offset		-10		10	mV
$V_{\text{(Scale_Err)}}$	SCD, SCC, and OCD scale error		-10%		10%	
Current Protection Timing						
$t_{\text{(OCDD)}}$	Overcurrent in discharge delay		1		31	ms
$t_{\text{(OCDD_STEP)}}$	OCDD Step options			2		ms
$t_{\text{(SCDD)}}$	Short circuit in discharge delay		0		1830	μs
$t_{\text{(SCDD_STEP)}}$	SCDD Step options			122		μs
$t_{\text{(SCCD)}}$	Short circuit in charge delay		0		915	μs
$t_{\text{(SCCD_STEP)}}$	SCCD Step options			61		μs
$t_{\text{(DETECT)}}$	Current fault detect time	$V_{\text{SRP-SRN}} = V_{\text{THRESH}} + 12.5\text{ mV}$, $T_A = -20^\circ\text{C}$ to 85°C		35	160	μs
t_{ACC}	Overcurrent and short circuit delay time accuracy	Accuracy of typical delay time with no WDI input		-50%	50%	
P-CH FET Drive						
$V_{\text{O(FETON)}}$	Output voltage, charge and discharge FETs on	$V_{\text{O(FETONDSG)}} = V_{\text{(BAT)}} - V_{\text{(DSG)}}$, $R_{\text{GS}} = 1\text{ M}\Omega$, $T_A = -20$ to 110°C , $\text{BAT} = 7.2\text{ V}$ ⁽⁷⁾	6	6.5	BAT	V
		$V_{\text{O(FETONCHG)}} = V_{\text{(PACK)}} - V_{\text{(CHG)}}$, $R_{\text{GS}} = 1\text{ M}\Omega$, $T_A = -20$ to 110°C , $\text{PACK} = 7.2\text{ V}$ ⁽⁷⁾	6	6.5	PACK	V
$V_{\text{O(FETOFF)}}$	Output voltage, charge and discharge FETs off	$V_{\text{O(FETOFFDSG)}} = V_{\text{(BAT)}} - V_{\text{(DSG)}}$, $T_A = -20^\circ\text{C}$ to 110°C , $\text{BAT} = 7.2\text{ V}$			0.2	V
		$V_{\text{O(FETOFFCHG)}} = V_{\text{(PACK)}} - V_{\text{(CHG)}}$, $T_A = -20^\circ\text{C}$ to 110°C , $\text{PACK} = 7.2\text{ V}$			0.2	V
t_r	Rise time	$C_L = 4700\text{ pF}$	VDSG: 10% to 90%	40	200	μs
			VCHG: 10% to 90%	40	200	
t_f	Fall time	$C_L = 4700\text{ pF}$	VDSG: 90% to 10%	40	200	
			VCHG: 90% to 10%	40	200	

(6) Specified by design. Not production tested.

(7) For a V_{BAT} or V_{PACK} input range of 3.8 V to 18.75 V, MIN $V_{\text{O(FETON)}}$ voltage is 9 V or $V_{\text{(BAT)}} - 1\text{ V}$, whichever is less.

ELECTRICAL CHARACTERISTICS (continued)

Typical values stated where $T_A = 25^\circ\text{C}$ and $V_{BAT} = V_{PACK} = 7.2\text{ V}$, Min/Max values stated where $T_A = -20^\circ\text{C}$ to 85°C and $V_{BAT} = V_{PACK} = 3.8\text{ V}$ to 18.75 V over operating free-air temperature range (unless otherwise noted)

PARAMETER		TEST CONDITION ⁽¹⁾	MIN	TYP	MAX	UNIT
Pre-Charge/ZVCHG FET Drive						
$V_{(PreCHGON)}$	$V_{O(PreCHGON)} = V_{(PACK)}$ $-V_{(ZVCHG)}$, pre-charge FET on ⁽⁸⁾	$R_{GS} = 1\text{ M}\Omega$, $V_{PACK} = 10\text{ V}$	9	9.5	10	V
$V_{(PreCHGOFF)}$	Output voltage, pre-charge FET off ⁽⁸⁾	$R_{GS} = 1\text{ M}\Omega$, $T_A = -20^\circ\text{C}$ to 110°C			$V_{BAT} - 0.5$	V
t_r	Rise time	$C_L = 4700\text{ pF}$, $R_G = 5.1\text{ k}\Omega$		80	200	μs
t_f	Fall time	$C_L = 4700\text{ pF}$, $R_G = 5.1\text{ k}\Omega$		1.7		ms
SMBus						
f_{SMB}	SMBus operating frequency	Slave mode, SMBC 50% duty cycle	10		100	kHz
f_{MAS}	SMBus master clock frequency	Master mode, no clock low slave extend		51.2		kHz
t_{BUF}	Bus free time between start and stop		4.7			μs
$t_{HD:STA}$	Hold time after (repeated) start		4			μs
$t_{SU:STA}$	Repeated start setup time		4.7			μs
$t_{SU:STO}$	Stop setup time		4			μs
$t_{HD:DAT}$	Data hold time	Receive mode	0			ns
		Transmit mode	300			
$t_{SU:DAT}$	Data setup time		250			ns
$t_{TIMEOUT}$	Error signal/detect		See ⁽⁹⁾		35	ms
t_{LOW}	Clock low period		4.7			μs
t_{HIGH}	Clock high period		See ⁽¹⁰⁾		50	μs
$t_{LOW:SEXT}$	Cumulative clock low slave extend time		See ⁽¹¹⁾		25	ms
$t_{LOW:MEXT}$	Cumulative clock low master extend time		See ⁽¹²⁾		10	ms
t_f	Clock/data fall time		See ⁽¹³⁾		300	ns
t_r	Clock/data rise time		See ⁽¹⁴⁾		1000	ns

(8) For a V_{BAT} or V_{PACK} input range of 3.8 V to 18.75 V, MIN $V_{O(FETON)}$ voltage is 9 V or $V_{(BAT)} - 1\text{ V}$, whichever is less.

(9) The bq28400 times out when any clock low exceeds $t_{TIMEOUT}$.

(10) $t_{HIGH:MAX}$ is the minimum bus idle time. SMBC = SMBD = 1 for $t > 50\text{ }\mu\text{s}$ causes reset of any transaction involving bq28400 that is in progress.

(11) $t_{LOW:SEXT}$ is the cumulative time a slave device is allowed to extend the clock cycles in one message from initial start to the stop.

(12) $t_{LOW:MEXT}$ is the cumulative time a master device is allowed to extend the clock cycles in one message from initial start to the stop.

(13) Rise time $t_r = V_{ILMAX} - 0.15$ to $(V_{IHMIN} + 0.15)$.

(14) Fall time $t_f = 0.9V_{DD}$ to $(V_{ILMAX} - 0.15)$.

PIN EQUIVALENT CIRCUITS

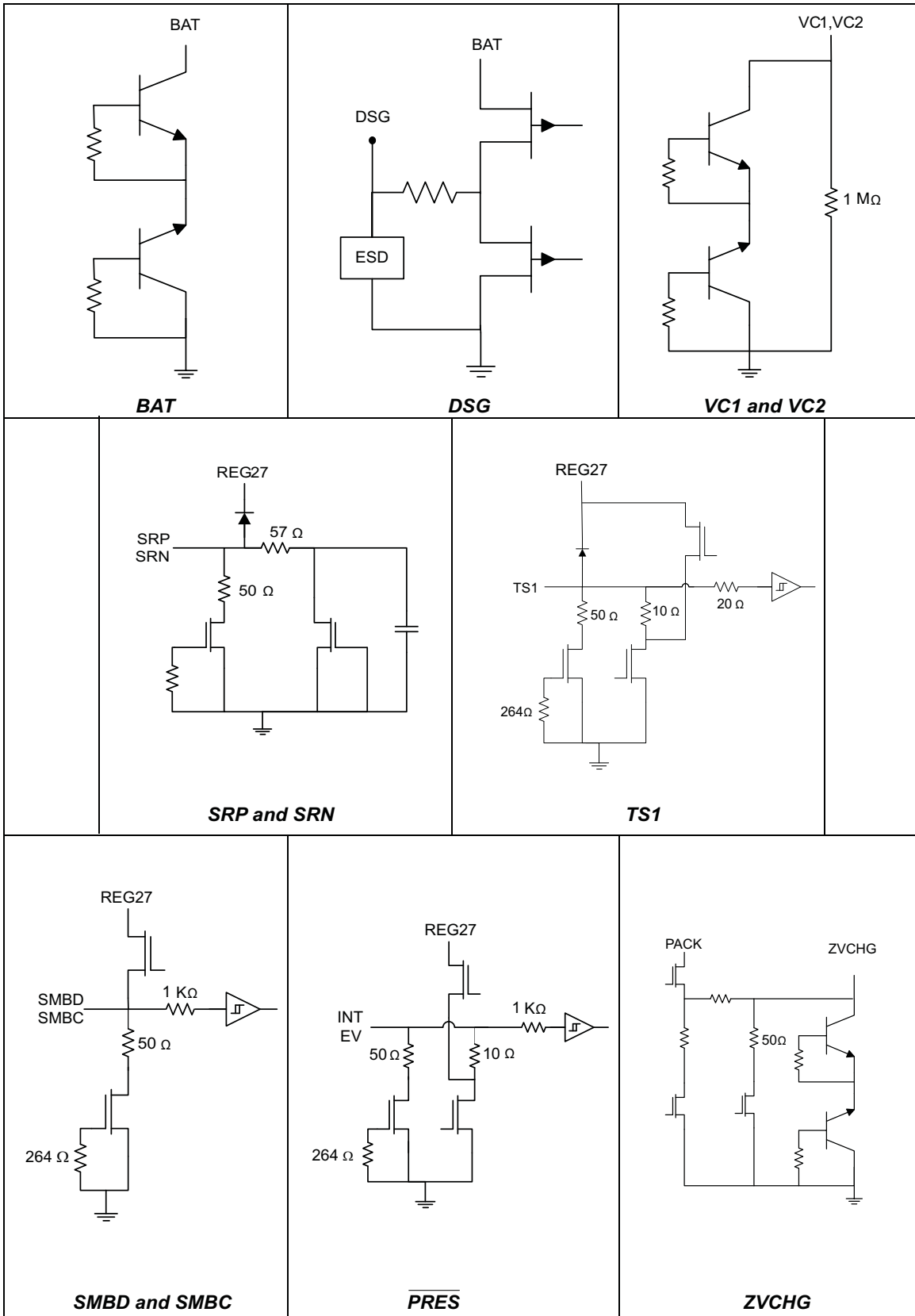

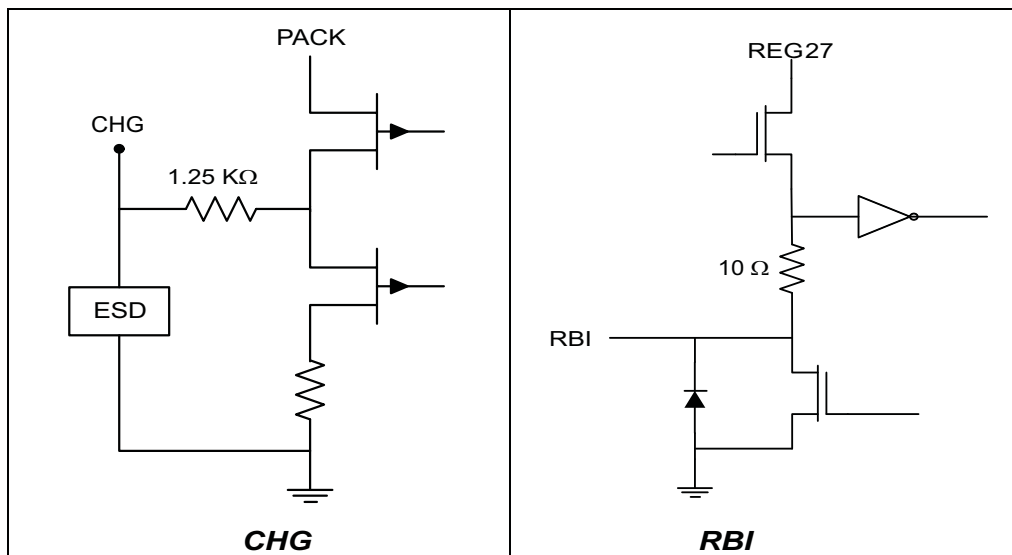
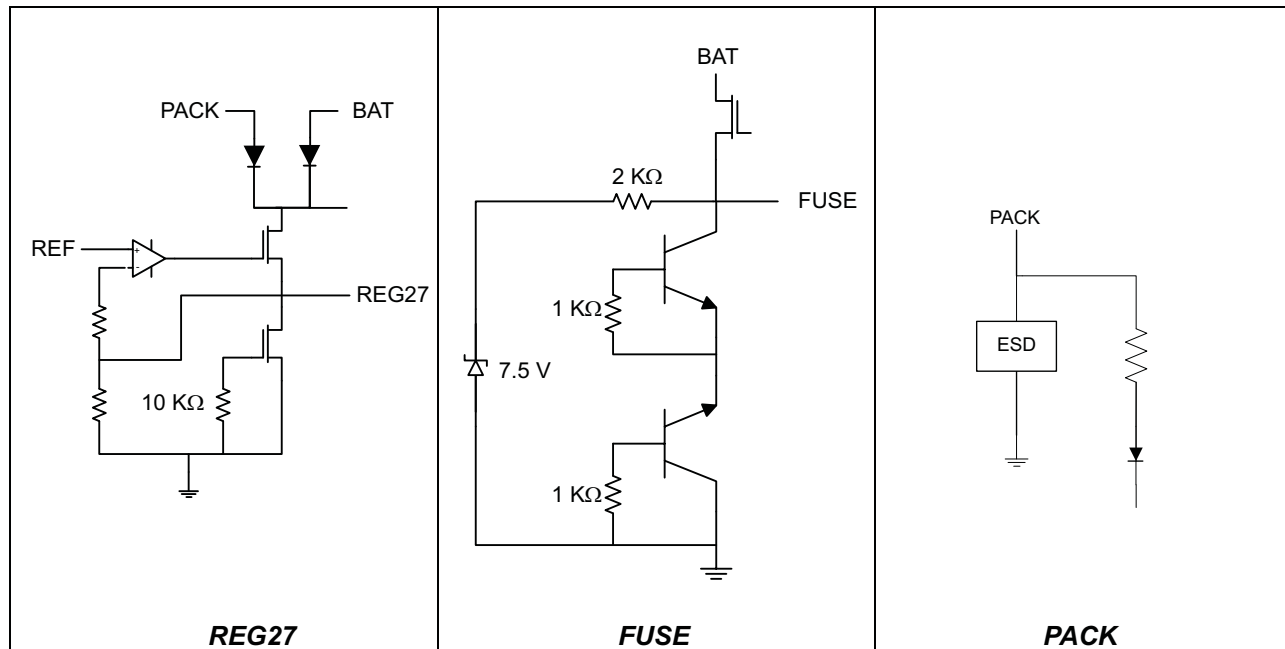

TIMING CIRCUITS

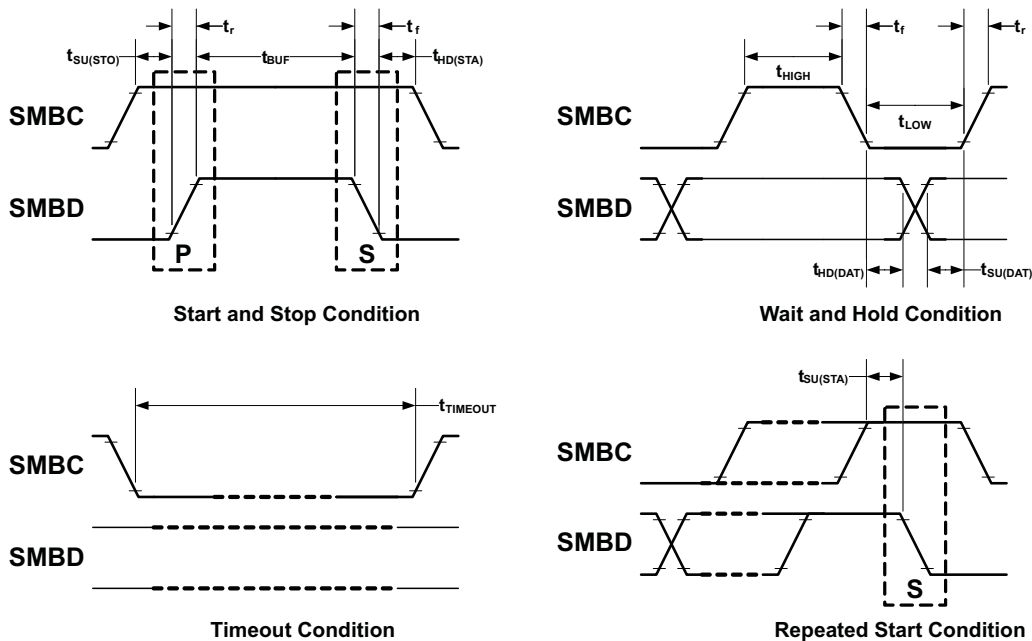

Figure 1. Timing Conditions

GENERAL OVERVIEW

The bq28400 has a flexible architecture that enables development of numerous battery-management solutions. The device is a fully integrated battery manager, as shown in the functional block diagram, and performs necessary calculations and control for a fully functional 2-series cell battery management system. The device provides flexible user settings that are stored in flash memory.

The bq28400 determines battery capacity by monitoring the amount of charge input or removal from 2-series cell Li-Ion rechargeable batteries via a small value series sense resistor. The device then controls and reports the battery status using corrections for environmental and operating conditions. Additional control and monitoring is implemented for individual cell voltages, temperature, and current.

FEATURE SET

Safety Features

The bq28400 supports a wide range of battery and system protection features that can be configured. The primary safety features include:

- Cell over/undervoltage protection
- Overcurrent during charge and discharge
- Short circuit
- Overtemperature during charge and discharge
- Device watchdog timer

The secondary safety features used to indicate more serious faults which can be used to control FET state or blow an in-line fuse to permanently disable the battery pack include:

- Safety overvoltage
- Safety undervoltage
- Safety overcurrent in charge and discharge
- Safety overtemperature in charge and discharge
- Charge, pre-charge, and discharge FET fault
- Cell imbalance detection

Charge Control

The bq28400 charge control features include:

- Reporting charging current needed for constant current charging and charging voltage needed for constant voltage charging to a smart charger using SMBus communications
- Supports pre-charging/zero-volt charging
- Supports fast charging
- Supports charge inhibit and charge suspend if battery pack temperature is out of temperature range
- Reports charging fault and also indicate charge status via charge and discharge alarms

Gas Gauging

The device uses advanced Compensated End-of-Discharge Voltage (CEDV) technology to measure and calculate the available charge capacity in battery cells under system use and environmental conditions. The device accumulates a measure of charge and discharge currents, then compensates the charge current measurement for temperature and the state-of-charge of the battery. The bq28400 further estimates battery self-discharge, adjusts the self-discharge estimation for temperature, and then updates internal status registers. These internal registers are made available to the system host via the two-wire SMBus.

The internal general-purpose SRAM can be powered by the RBI pin of the bq28400 if power is lost. Typically, a 0.1- μ F capacitor provides the necessary voltage to the SRAM array during inadvertent momentary power loss.

See the bq28400 technical reference guide for further details.

Lifetime Data Logging

The bq28400 maintains the highest temperature value from the last device reset.

Power Modes

The bq28400 supports three power modes to reduce power consumption:

- In Normal Mode, the device performs measurements, calculations, protection decisions, and data updates in 1-second intervals. Between these intervals, the device is in a reduced power stage.
- In Sleep Mode, the bq28400 performs measurements, calculations, protection decisions and data updates in longer intervals. Between these intervals, the device is in a reduced power stage.
 - A wake function operates so that an exit from Sleep mode occurs when current flow, detection of failure,

or SMBus activity detected.

- In Shutdown Mode, the bq28400 is completely disabled by turning off all FETs and powering down the bq28400.

CONFIGURATION

Oscillator Function

The bq28400 fully integrates the system oscillator; therefore, no external components are required for this feature.

System Present Operation

The device checks the $\overline{\text{PRES}}$ pin periodically. If the $\overline{\text{PRES}}$ pin input is pulled to ground by the external system, the bq28400 detects this event as the presence of the system.

2-Series Cell Configuration

The bq28400 supports 2-series cell battery pack configurations.

Cell Balancing Configuration

If cell balancing is required, the bq28400 cell balance control enables a weak, internal pull-down for each VCx pin. The purpose of this weak pull-down is to enable an external FET for current bypass. Series resistors placed between the input VCx pins and the positive battery cell terminals control the VGS of the external FET. Alternatively, CB_EN output can be used with the bq29200 device to control the auto cell-balancing feature for the system (see [Figure 5](#)). Further details are provided in the [APPLICATION INFORMATION](#) section of this document.

BATTERY PARAMETER MEASUREMENTS

The bq28400 uses an integrating delta-sigma analog-to-digital converter (ADC) for current measurement, and a second delta-sigma ADC for individual cell voltage, battery voltage, and temperature measurements. The individual cell voltages, *Voltage*, *Current*, *AverageCurrent*, and *Temperature* are updated in 1-second intervals during normal operation.

Charge and Discharge Counting

The integrating ADC measures the charge and discharge flow of the battery by monitoring a small-value sense resistor between the SRP and SRN pins. The bq28400 integrating ADC measures bipolar signals across the SRP and SRN pins from -0.20 V to 0.25 V induced by current through the sense resistor (typically $5\text{ m}\Omega$ to $20\text{ m}\Omega$). Charge activity is detected when $V_{\text{SR}} = V_{\text{SRP}} - V_{\text{SRN}}$ is positive and discharge activity when $V_{\text{SR}} = V_{\text{SRP}} - V_{\text{SRN}}$ is negative. The bq28400 continuously integrates the signal over time, using an internal counter and updates *RemainingCapacity* with the charge or discharge amount every second.

Voltage

While monitoring the SRP and SRN pins for charge and discharge currents, the bq28400 monitors the individual series cell voltages. The internal bq28400 ADC then measures the voltage, scales, applies offsets, and calibrates it appropriately.

NOTE

For accurate differential voltage sensing, the VSS ground should be connected directly to the most negative terminal of the battery stack, not to the positive side of the sense resistor. This minimizes the voltage drop across the PCB trace.

Voltage Calibration and Accuracy

The bq28400 is calibrated for voltage prior to shipping from TI. The bq28400 voltage measurement signal chain (ADC, high voltage translation, circuit interconnect) is calibrated for each cell. The external filter resistors, connected from each cell to the VCx input of the bq28400, are required to be $1\text{ k}\Omega$. If different voltage accuracy is desired, customer voltage calibration is required.

Current

The bq28400 uses the SRP and SRN inputs to measure and calculate the battery charge and discharge current using a 5-m Ω to 20-m Ω typical sense resistor.

Temperature

The bq28400 has an internal temperature sensor and input pin for an external temperature sensor. The bq28400 can be configured to use either the internal or external temperature sensor. The default setting for the bq28400 is for a Semitec 103AT thermistor as input to the TS1 pin. Reporting of measured temperature is available by way of the SBS Temperature command.

COMMUNICATIONS

The bq28400 uses SMBus v1.1 in Slave Mode per the SBS specification.

SBS Commands

Table 1. SBS COMMANDS

SBS Command	Mode	Name	Format	Min Value	Max Value	Default Value	Unit
0x00	R/W	ManufacturerAccess	H2	0x0000	0xffff	—	
0x03	R/W	BatteryMode	H2	0x0000	0xe383	—	
0x08	R	Temperature	U2	0	65535	—	0.1°K
0x09	R	Voltage	U2	0	65535	—	mV
0x0a	R	Current	I2	–32768	32767	—	mA
0x0b	R	AverageCurrent	I2	–32768	32767	—	mA
0x0c	R	MaxError	U1	0	100	—	%
0x0d	R	RelativeStateOfCharge	U1	0	100	—	%
0x0f	R/W	RemainingCapacity	U2	0	65535	—	mAh or 10 mWh
0x10	R	FullChargeCapacity	U2	0	65535	7200	mAh
0x14	R	ChargingCurrent	U2	0	65534	2500	mA
0x15	R	ChargingVoltage	U2	0	65534	12600	mV
0x16	R	BatteryStatus	U2	0x0000	0xdbff	—	
0x17	R/W	CycleCount	U2	0	65535	0	
0x18	R/W	DesignCapacity	U2	0	65535	7200	mAh
0x19	R/W	DesignVoltage	U2	0	65535	10800	mV
0x1a	R/W	SpecificationInfo	H2	0x0000	0xffff	0x0031	
0x1b	R/W	ManufactureDate	U2	—	—	0	ASCII
0x1c	R/W	SerialNumber	H2	0x0000	0xffff	0x0001	
0x20	R/W	ManufacturerName	S12	—	—	Texas Inst.	ASCII
0x21	R/W	DeviceName	S8	—	—	bq28400	ASCII
0x22	R/W	DeviceChemistry	S5	—	—	LION	ASCII
0x23	R/W	ManufacturerData	S9	—	—	—	ASCII
0x2f	R/W	Authenticate	S21	—	—	—	ASCII
0x3e	R	CellVoltage2	U2	0	65535	—	mV
0x3f	R	CellVoltage1	U2	0	65535	—	mV

Extended SBS Commands

Table 2 shows the extended SBS commands for the device.

Table 2. Extended SBS Commands

SBS Cmd	Mode	Name	Format	Size in Bytes	Min Value	Max Value	Default Value	Unit
0x61	R/W	FullAccessKey	hex	4	0x00000000	0xffffffff	—	
0x63	R/W	AuthenKey3	hex	4	0x00000000	0xffffffff	—	
0x64	R/W	AuthenKey2	hex	4	0x00000000	0xffffffff	—	
0x65	R/W	AuthenKey1	hex	4	0x00000000	0xffffffff	—	
0x66	R/W	AuthenKey0	hex	4	0x00000000	0xffffffff	—	

APPLICATION INFORMATION

Run Time to Empty

To predict how much run time the battery pack can supply to the host system, a “Run Time To Empty” value can be calculated.

The SBS host system needs to read, store, and update the following values during a discharging period and average them over a user-determined period of time:

- DSG bit of the BatteryStatus register (ensure that it is in discharge mode)
- AverageCurrent (mA)
 - Positive value = charge current
 - Negative value = discharge current
 - One minute rolling average of current (the user can accumulate this time for improved granularity)
- RemainingCapacity (mAh)

Then calculating:

$\text{RunTimeToEmpty} = \text{RemainingCapacity}(\text{avg mAh}) \div \text{AverageCurrent}(\text{avg mA})$ (The result will be in hours. For minutes, the user can take the above results and divide by 60.)

Charging Time to Full

To predict how much charging time before the battery pack is fully charged, a “Run Time To Full” value can be calculated.

The SBS host system needs to read, store, and update the following values during a charging period and average them over a user-determined period of time:

- DSG bit of the BatteryStatus register (specify in charge mode)
- AverageCurrent (mA)
 - Positive value = charge current
 - Negative value = discharge current
 - One minute rolling average of current (the user can accumulate this time for improved granularity)
- RemainingCapacity (mAh)

Then calculating:

$\text{RunTimeToFull} = [\text{FullChargeCapacity}(\text{avg mAh}) - \text{RemainingCapacity}(\text{avg mAh})] \div \text{AverageCurrent}(\text{avg mA})$

Remaining Capacity Alert

To provide enough time for action to be taken when the battery is below a pre-determined capacity, the user may implement a remaining capacity alarm alert in the SMBus host system. To do this, an SMBus read of the *RemainingCapacity* value should be completed then compared by the SMBus host to a user-selected value. If the read *RemainingCapacity* value is < the user's Remaining Capacity, then the host system should instruct the user of what action is needed.

Remaining Time Alert

Similar to the Remaining Capacity notification, the system operation may need an alarm notification based on time rather than remaining capacity. To do this, a determination of the *EndTimeToEmpty* (as discussed below) and compared by SMBus host to a user-selected remaining time limit value. If the *RemainingTimeLimit* value is < *EndTimeToEmpty*, then the host system should instruct the user of the action to be taken.

Cell Balancing

Cell balancing increases the useful life of battery packs. Cell-to-cell differences in self-discharge, capacity, and impedance can lead to different charge states among the cells; however, the charger terminates the charge based on the summed voltage only, which may leave some cells undercharged and others overcharged. To remedy this imbalance and to achieve the goal of having all cells reach 100% state-of-charge at charge termination, it is necessary to reduce the charge added to the overcharged cells by creating a current bypass during charging.

Cell balancing in the bq28400 is accomplished by connecting an external parallel bypass load to each cell and enabling the bypass load depending on each individual cell's charge state. The bypass load is typically formed by a P-CH MOSFET and a resistor. The series resistors that connect the cell tabs to VC1~VC2 pins of the bq28400 are required to be 1 k Ω . The bq28400 balances the cells during charge by discharging those cells above the threshold set in *Cell Balance Threshold*, if the maximum difference in cell voltages exceeds the value programmed in *Cell Balance Min*. During cell balancing, the bq28400 measures the cell voltages at an interval set in *Cell Balance Interval*. On the basis of the cell voltages, the bq28400 either selects the appropriate cell to discharge or adjusts the cell balance threshold up by the value programmed in *Cell Balance Window* when all cells exceed the cell balance threshold or the highest cell exceeds the cell balance threshold by the cell balance window.

Cell balancing only occurs when charging current is detected and the cell balance threshold is reset to the value in *Cell Balance Threshold* at the start of every charge cycle. The threshold is only adjusted once during any balance interval.

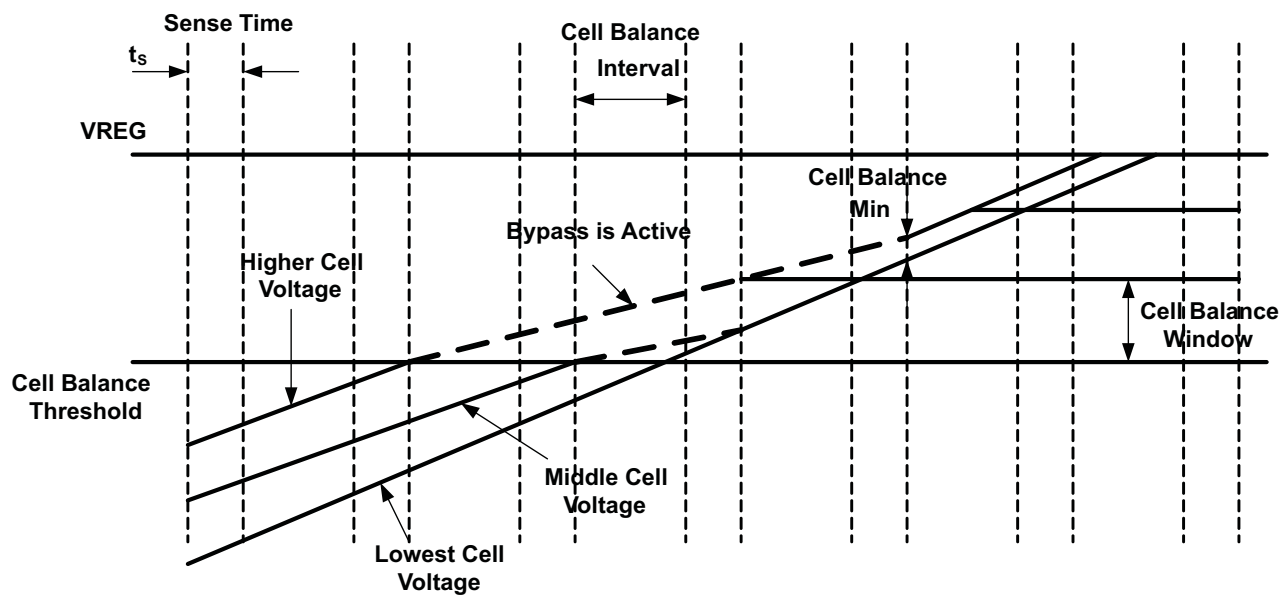
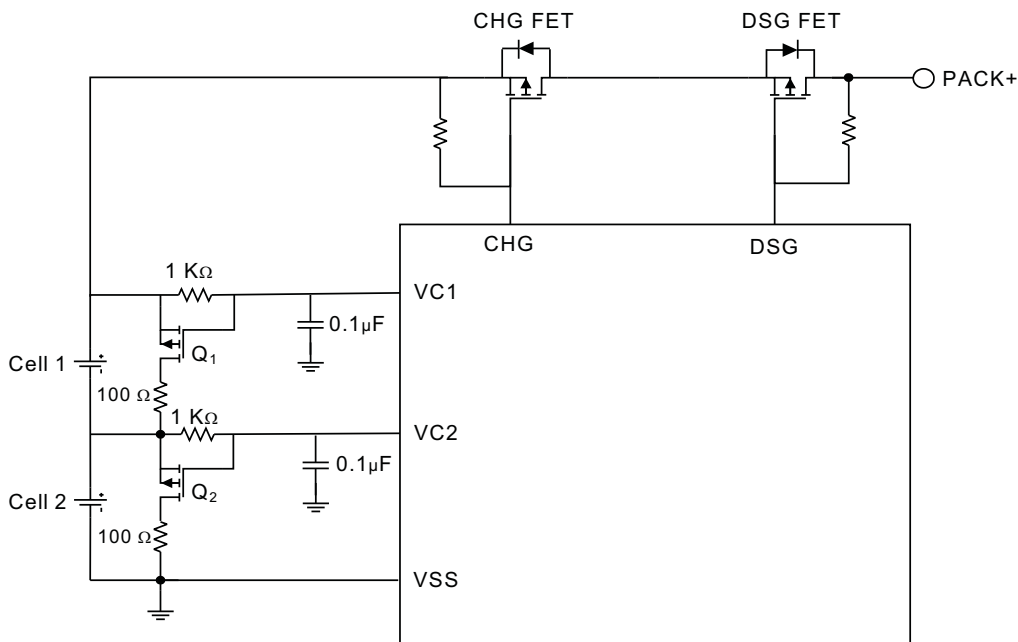

Figure 2. Cell Balance

The bq28400 supports cell balancing using an external MOSFET, as illustrated in [Figure 3](#).

[Figure 3](#) shows an example of a cell-balancing circuit for a 2-series cell application. In this circuit, Q1 and Q2 are the external MOSFETs—specifically, Si1023 P-channel MOSFETs. These FETs were chosen because of its low gate-to-source threshold voltage.



NOTE: Q1 and Q2 are Si1023 type P-CH FETs

Figure 3. Internal Cell Balancing Control Circuit

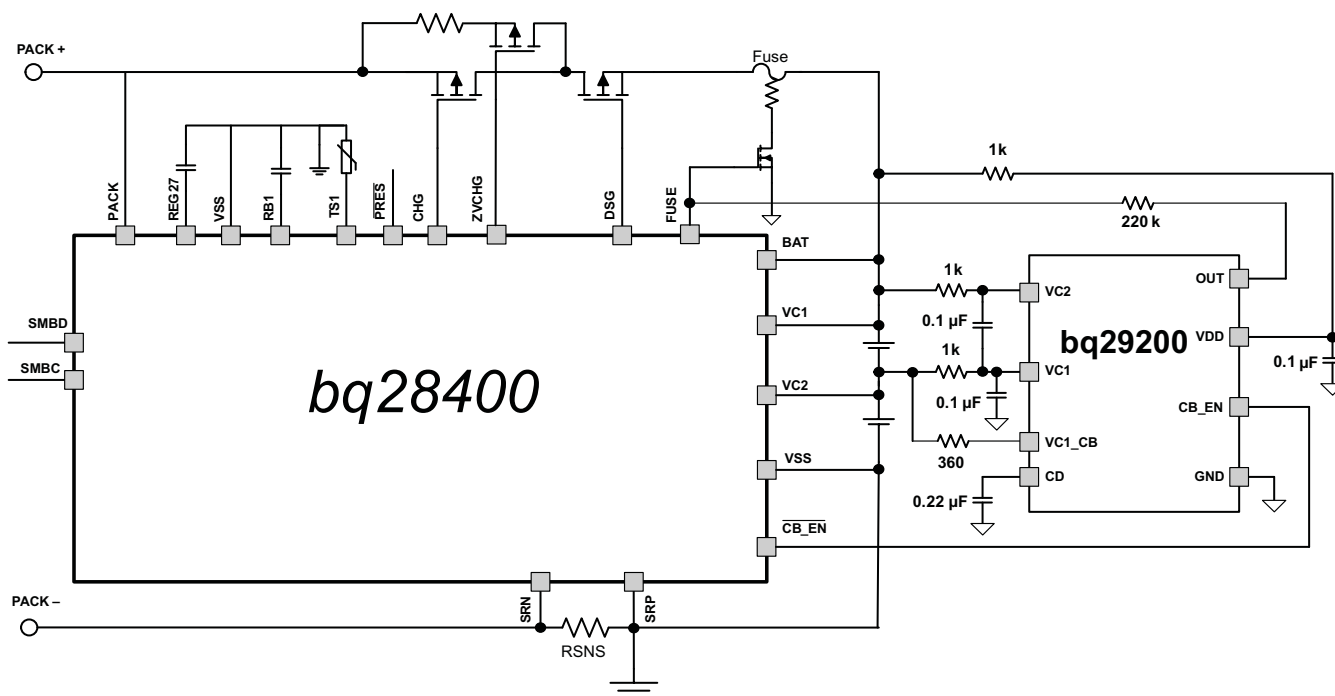

Figure 4. External Auto Cell Balancing Circuit

Layout Recommendations

For an accurate differential voltage sensing, the VSS ground should be connected directly to the most negative terminal of the battery stack, not to the positive side of the sense resistor. This minimizes the voltage drop across the PCB trace.

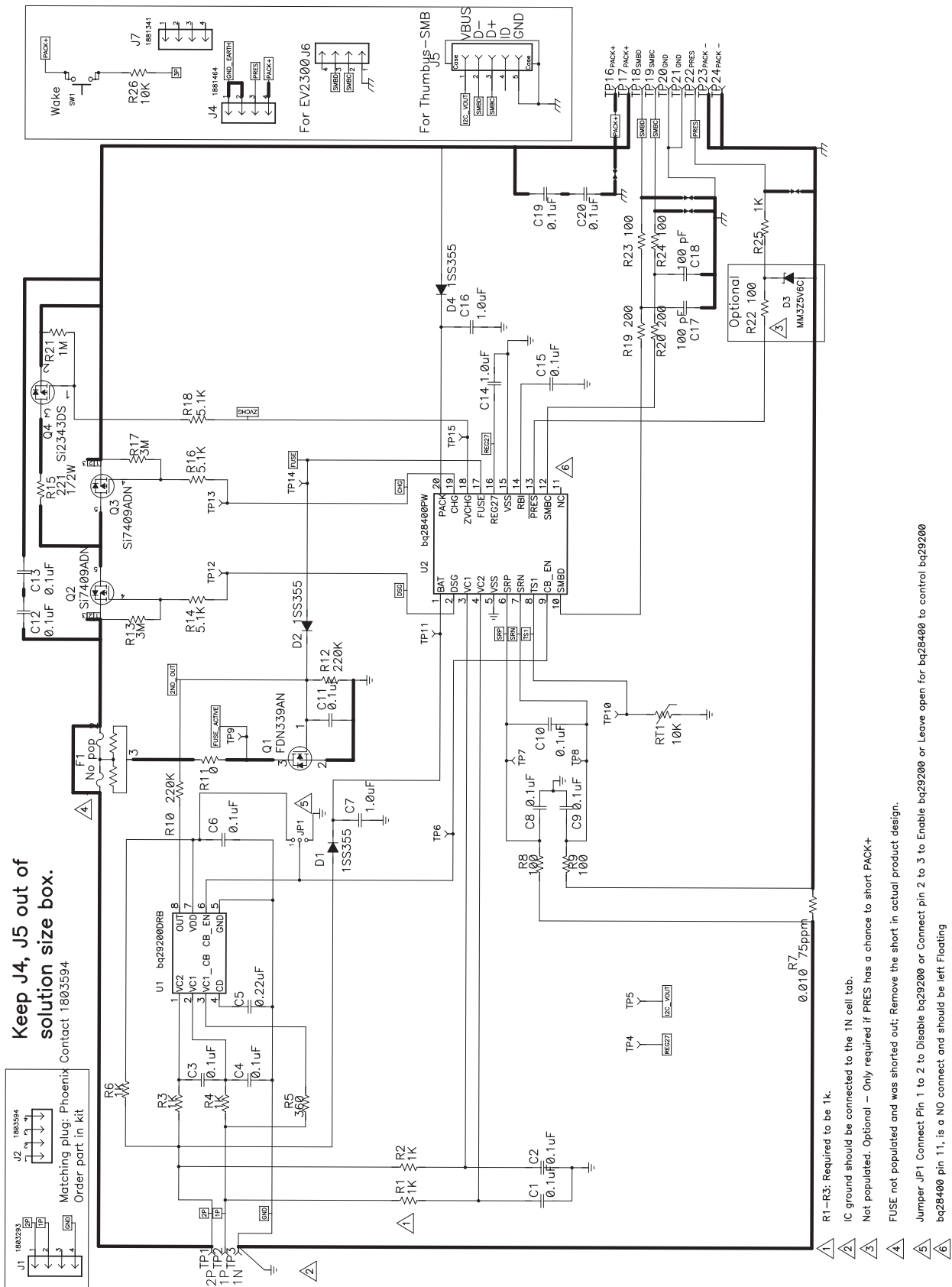

Figure 5. Application Schematic

PACKAGING INFORMATION

Orderable Device	Status ⁽¹⁾	Package Type	Package Drawing	Pins	Package Qty	Eco Plan ⁽²⁾	Lead/ Ball Finish	MSL Peak Temp ⁽³⁾	Samples (Requires Login)
BQ28400PW	ACTIVE	TSSOP	PW	20	70	Green (RoHS & no Sb/Br)	CU NIPDAU	Level-2-260C-1 YEAR	
BQ28400PWR	ACTIVE	TSSOP	PW	20	2000	Green (RoHS & no Sb/Br)	CU NIPDAU	Level-2-260C-1 YEAR	

⁽¹⁾ The marketing status values are defined as follows:

ACTIVE: Product device recommended for new designs.

LIFEBUY: TI has announced that the device will be discontinued, and a lifetime-buy period is in effect.

NRND: Not recommended for new designs. Device is in production to support existing customers, but TI does not recommend using this part in a new design.

PREVIEW: Device has been announced but is not in production. Samples may or may not be available.

OBsolete: TI has discontinued the production of the device.

⁽²⁾ Eco Plan - The planned eco-friendly classification: Pb-Free (RoHS), Pb-Free (RoHS Exempt), or Green (RoHS & no Sb/Br) - please check <http://www.ti.com/productcontent> for the latest availability information and additional product content details.

TBD: The Pb-Free/Green conversion plan has not been defined.

Pb-Free (RoHS): TI's terms "Lead-Free" or "Pb-Free" mean semiconductor products that are compatible with the current RoHS requirements for all 6 substances, including the requirement that lead not exceed 0.1% by weight in homogeneous materials. Where designed to be soldered at high temperatures, TI Pb-Free products are suitable for use in specified lead-free processes.

Pb-Free (RoHS Exempt): This component has a RoHS exemption for either 1) lead-based flip-chip solder bumps used between the die and package, or 2) lead-based die adhesive used between the die and leadframe. The component is otherwise considered Pb-Free (RoHS compatible) as defined above.

Green (RoHS & no Sb/Br): TI defines "Green" to mean Pb-Free (RoHS compatible), and free of Bromine (Br) and Antimony (Sb) based flame retardants (Br or Sb do not exceed 0.1% by weight in homogeneous material)

⁽³⁾ MSL, Peak Temp. -- The Moisture Sensitivity Level rating according to the JEDEC industry standard classifications, and peak solder temperature.

Important Information and Disclaimer: The information provided on this page represents TI's knowledge and belief as of the date that it is provided. TI bases its knowledge and belief on information provided by third parties, and makes no representation or warranty as to the accuracy of such information. Efforts are underway to better integrate information from third parties. TI has taken and continues to take reasonable steps to provide representative and accurate information but may not have conducted destructive testing or chemical analysis on incoming materials and chemicals. TI and TI suppliers consider certain information to be proprietary, and thus CAS numbers and other limited information may not be available for release.

In no event shall TI's liability arising out of such information exceed the total purchase price of the TI part(s) at issue in this document sold by TI to Customer on an annual basis.

TAPE AND REEL INFORMATION

REEL DIMENSIONS

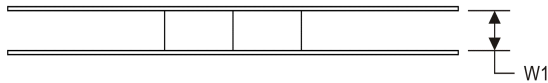

TAPE DIMENSIONS

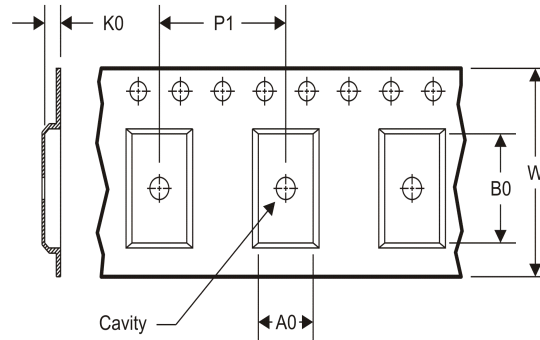

A0	Dimension designed to accommodate the component width
B0	Dimension designed to accommodate the component length
K0	Dimension designed to accommodate the component thickness
W	Overall width of the carrier tape
P1	Pitch between successive cavity centers

TAPE AND REEL INFORMATION

*All dimensions are nominal

Device	Package Type	Package Drawing	Pins	SPQ	Reel Diameter (mm)	Reel Width W1 (mm)	A0 (mm)	B0 (mm)	K0 (mm)	P1 (mm)	W (mm)	Pin1 Quadrant
BQ28400PWR	TSSOP	PW	20	2000	330.0	16.4	6.95	7.1	1.6	8.0	16.0	Q1

TAPE AND REEL BOX DIMENSIONS



*All dimensions are nominal

Device	Package Type	Package Drawing	Pins	SPQ	Length (mm)	Width (mm)	Height (mm)
BQ28400PWR	TSSOP	PW	20	2000	367.0	367.0	38.0

PW (R-PDSO-G20)

PLASTIC SMALL OUTLINE

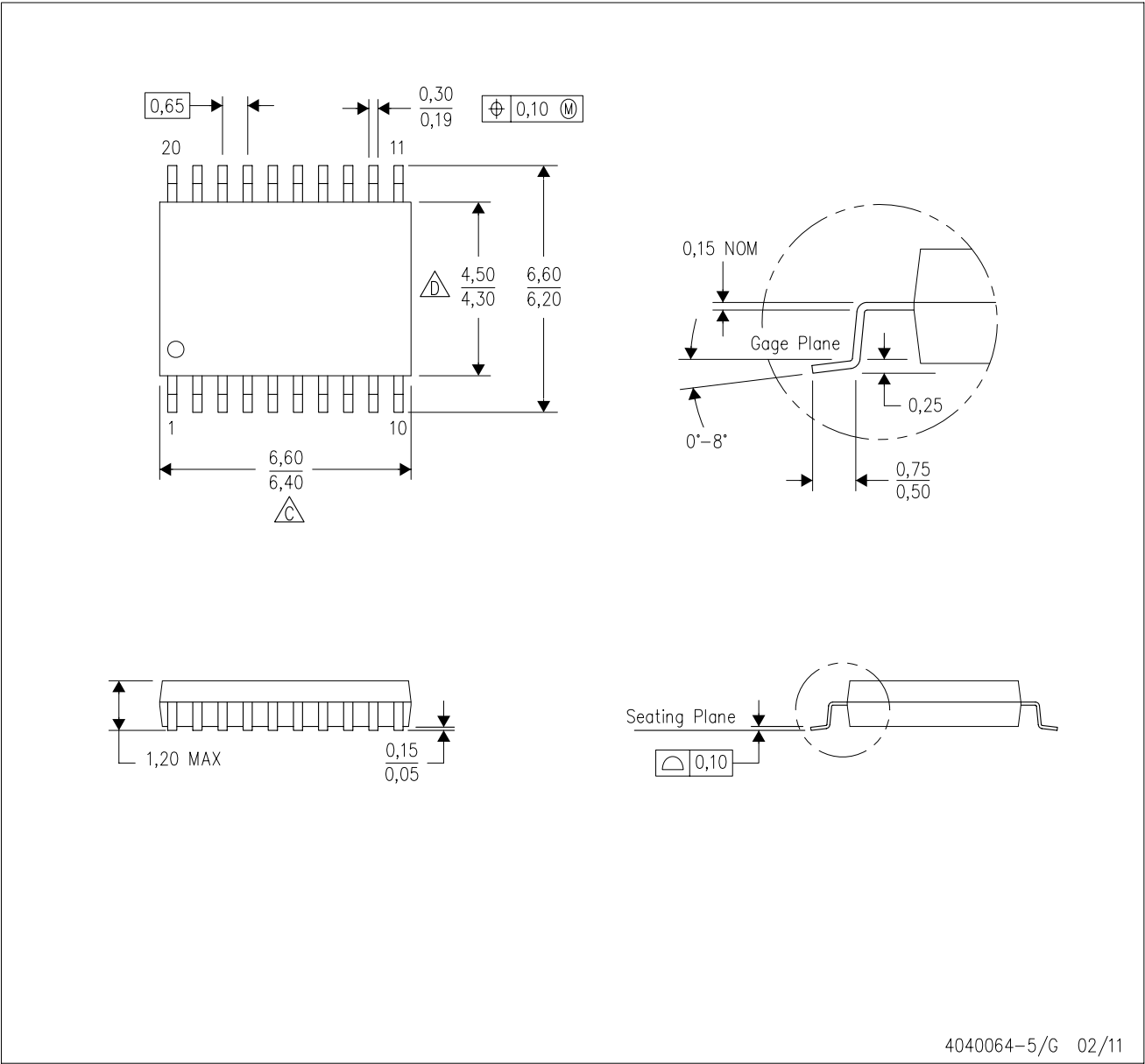

4040064-5/G 02/11

- NOTES:
- A. All linear dimensions are in millimeters. Dimensioning and tolerancing per ASME Y14.5M-1994.
 - B. This drawing is subject to change without notice.
 - C. Body length does not include mold flash, protrusions, or gate burrs. Mold flash, protrusions, or gate burrs shall not exceed 0,15 each side.
 - D. Body width does not include interlead flash. Interlead flash shall not exceed 0,25 each side.
 - E. Falls within JEDEC MO-153

PW (R-PDSO-G20)

PLASTIC SMALL OUTLINE

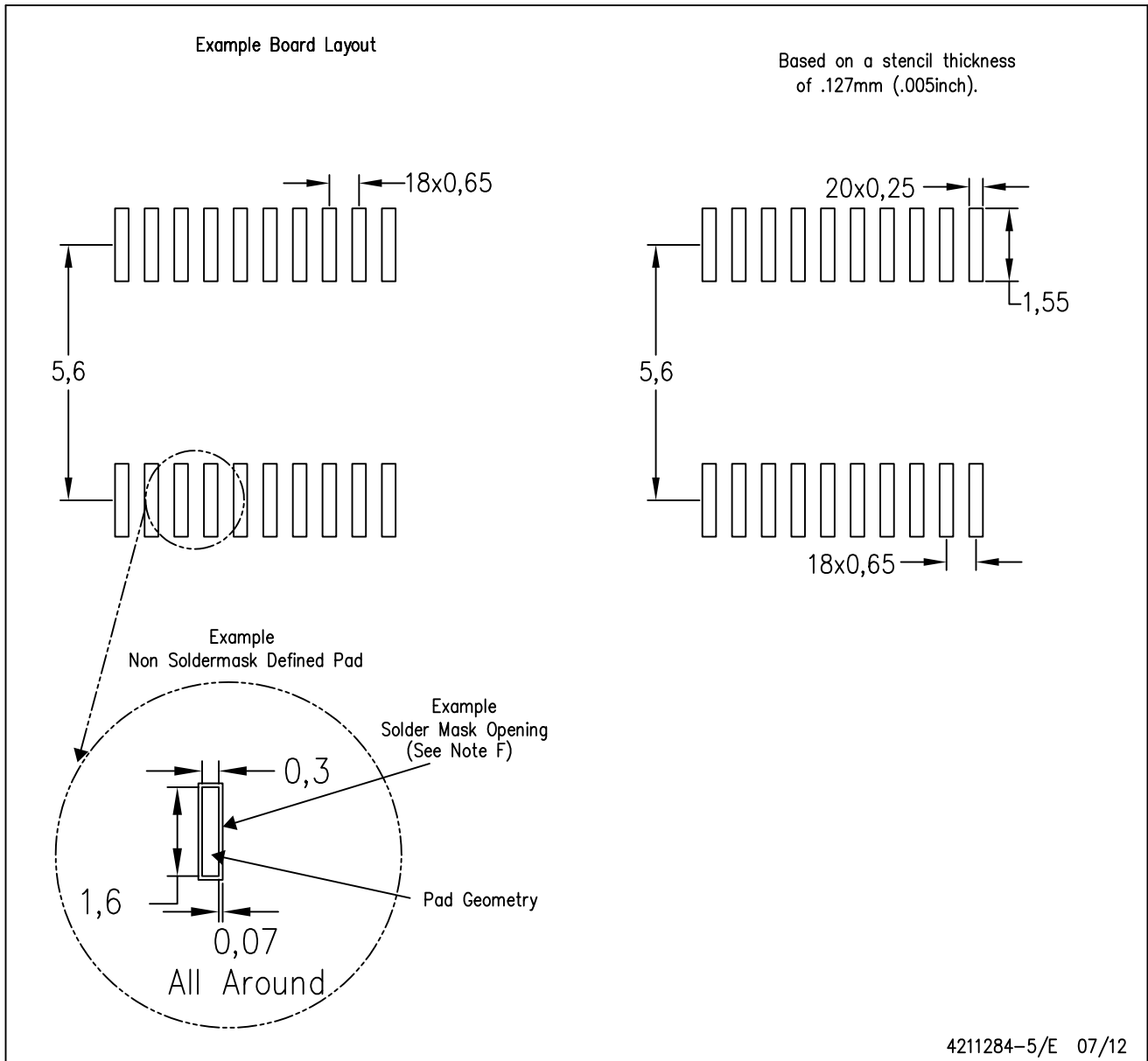

- NOTES:
- A. All linear dimensions are in millimeters.
 - B. This drawing is subject to change without notice.
 - C. Publication IPC-7351 is recommended for alternate design.
 - D. Laser cutting apertures with trapezoidal walls and also rounding corners will offer better paste release. Customers should contact their board assembly site for stencil design recommendations. Refer to IPC-7525 for other stencil recommendations.
 - E. Customers should contact their board fabrication site for solder mask tolerances between and around signal pads.

IMPORTANT NOTICE

Texas Instruments Incorporated and its subsidiaries (TI) reserve the right to make corrections, enhancements, improvements and other changes to its semiconductor products and services per JESD46C and to discontinue any product or service per JESD48B. Buyers should obtain the latest relevant information before placing orders and should verify that such information is current and complete. All semiconductor products (also referred to herein as "components") are sold subject to TI's terms and conditions of sale supplied at the time of order acknowledgment.

TI warrants performance of its components to the specifications applicable at the time of sale, in accordance with the warranty in TI's terms and conditions of sale of semiconductor products. Testing and other quality control techniques are used to the extent TI deems necessary to support this warranty. Except where mandated by applicable law, testing of all parameters of each component is not necessarily performed.

TI assumes no liability for applications assistance or the design of Buyers' products. Buyers are responsible for their products and applications using TI components. To minimize the risks associated with Buyers' products and applications, Buyers should provide adequate design and operating safeguards.

TI does not warrant or represent that any license, either express or implied, is granted under any patent right, copyright, mask work right, or other intellectual property right relating to any combination, machine, or process in which TI components or services are used. Information published by TI regarding third-party products or services does not constitute a license to use such products or services or a warranty or endorsement thereof. Use of such information may require a license from a third party under the patents or other intellectual property of the third party, or a license from TI under the patents or other intellectual property of TI.

Reproduction of significant portions of TI information in TI data books or data sheets is permissible only if reproduction is without alteration and is accompanied by all associated warranties, conditions, limitations, and notices. TI is not responsible or liable for such altered documentation. Information of third parties may be subject to additional restrictions.

Resale of TI components or services with statements different from or beyond the parameters stated by TI for that component or service voids all express and any implied warranties for the associated TI component or service and is an unfair and deceptive business practice. TI is not responsible or liable for any such statements.

Buyer acknowledges and agrees that it is solely responsible for compliance with all legal, regulatory and safety-related requirements concerning its products, and any use of TI components in its applications, notwithstanding any applications-related information or support that may be provided by TI. Buyer represents and agrees that it has all the necessary expertise to create and implement safeguards which anticipate dangerous consequences of failures, monitor failures and their consequences, lessen the likelihood of failures that might cause harm and take appropriate remedial actions. Buyer will fully indemnify TI and its representatives against any damages arising out of the use of any TI components in safety-critical applications.

In some cases, TI components may be promoted specifically to facilitate safety-related applications. With such components, TI's goal is to help enable customers to design and create their own end-product solutions that meet applicable functional safety standards and requirements. Nonetheless, such components are subject to these terms.

No TI components are authorized for use in FDA Class III (or similar life-critical medical equipment) unless authorized officers of the parties have executed a special agreement specifically governing such use.

Only those TI components which TI has specifically designated as military grade or "enhanced plastic" are designed and intended for use in military/aerospace applications or environments. Buyer acknowledges and agrees that any military or aerospace use of TI components which have **not** been so designated is solely at the Buyer's risk, and that Buyer is solely responsible for compliance with all legal and regulatory requirements in connection with such use.

TI has specifically designated certain components which meet ISO/TS16949 requirements, mainly for automotive use. Components which have not been so designated are neither designed nor intended for automotive use; and TI will not be responsible for any failure of such components to meet such requirements.

Products

Audio	www.ti.com/audio
Amplifiers	amplifier.ti.com
Data Converters	dataconverter.ti.com
DLP® Products	www.dlp.com
DSP	dsp.ti.com
Clocks and Timers	www.ti.com/clocks
Interface	interface.ti.com
Logic	logic.ti.com
Power Mgmt	power.ti.com
Microcontrollers	microcontroller.ti.com
RFID	www.ti-rfid.com
OMAP Mobile Processors	www.ti.com/omap
Wireless Connectivity	www.ti.com/wirelessconnectivity

Applications

Automotive and Transportation	www.ti.com/automotive
Communications and Telecom	www.ti.com/communications
Computers and Peripherals	www.ti.com/computers
Consumer Electronics	www.ti.com/consumer-apps
Energy and Lighting	www.ti.com/energy
Industrial	www.ti.com/industrial
Medical	www.ti.com/medical
Security	www.ti.com/security
Space, Avionics and Defense	www.ti.com/space-avionics-defense
Video and Imaging	www.ti.com/video

TI E2E Community e2e.ti.com