

December 1992

Features

- High Voltage Type (20V Rating)
- CD40102BMS: 2-Decade BCD Type
- CD40103BMS: 8-Bit Binary Type
- Synchronous or Asynchronous Preset
- Medium Speed Operation
 - $f_{CL} = 3.6\text{MHz}$ (Typ) at 10V
- Cascadable
- 100% Tested for Quiescent Current at 20V
- Maximum Input Current of $1\mu\text{A}$ at 18V Over Full Package Temperature Range; 100nA at 18V and $+25^\circ\text{C}$
- Noise Margin (Over Full Package/Temperature Range)
 - 1V at $V_{DD} = 5\text{V}$
 - 2V at $V_{DD} = 10\text{V}$
 - 2.5V at $V_{DD} = 15\text{V}$
- Standardized Symmetrical Output Characteristics
- 5V, 10V and 15V Parametric Ratings
- Meets All Requirements of JEDEC Tentative Standard No. 13B, "Standard Specifications for Description of 'B' Series CMOS Devices"

Applications

- Divide-By- "N" Counters
- Programmable Times
- Interrupt Timers
- Cycle/Program Counter

Pinout

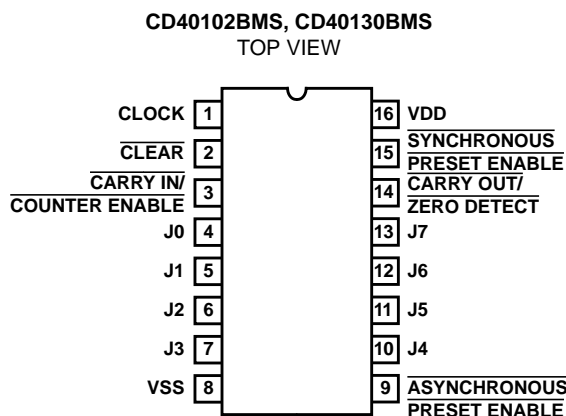

Description

CD40102BMS and CD40103BMS consist of an 8-stage synchronous down counter with a single output which is active when the internal count is zero. The CD40102BMS is configured as two cascaded 4-bit BCD counters, and the CD40103BMS contains a single 8-bit binary counter. Each type has control inputs for enabling or disabling the clock, for clearing the counter to its maximum count, and for presetting the counter either synchronously or asynchronously. All control inputs and the CARRY-OUT/ZERO-DETECT output are active-low logic.

In normal operation, the counter is decremented by one count on each positive transition of the CLOCK. Counting is inhibited when the CARRY-IN/COUNTER ENABLE ($\overline{CI/CE}$) inputs is high. The CARRY-OUT/ZERO-DETECT ($\overline{CO/ZD}$) output goes low when the count reaches zero if the $\overline{CI/CE}$ input is low, and remains low for one full clock period.

When the SYNCHRONOUS PRESET-ENABLE (\overline{SPE}) input is low, data at the JAM input is clocked into the counter on the next positive clock transition regardless of the state of the $\overline{CI/CE}$ input. When the ASYNCHRONOUS PRESET-ENABLE (\overline{APE}) input is low, data at the JAM inputs is asynchronously forced into the counter regardless of the state of the \overline{SPE} , $\overline{CI/CE}$, or CLOCK inputs. JAM inputs J0-J7 represent two 4-bit BCD words for the CD40102BMS and a single 8-bit binary word for the CD40103BMS.

When the CLEAR (\overline{CLR}) input is low, the counter is asynchronously cleared to its maximum count (99_{10} for the CD40102BMS and 255_{10} for the CD40103BMS) regardless of the state of any other input. The precedence relationship between control inputs is indicated in the truth table.

If all control inputs except $\overline{CI/CE}$ are high at the time of zero count, the counters will jump to the maximum count, giving a counting sequence of 100 or 256 clock pulses long.

This causes the $\overline{CO/ZD}$ output to go low to enable the clock on each succeeding clock pulse.

The CD40102BMS and CD40103BMS may be cascaded using the $\overline{CI/CE}$ input and the $\overline{CO/ZD}$ output, in either a synchronous or ripple mode as shown in Figures 16 and 17.

The CD40102MS and CD40103BMS are supplied in these 16-lead outline packages:

Braze Seal DIP	*H4W	†H4X
Frit Seal DIP	*H1L	†H1F
Ceramic Flatpack	H6W	
*CD40102B Only		†CD40130B Only

Specifications CD40102BMS, CD40103BMS

Absolute Maximum Ratings

DC Supply Voltage Range, (VDD)	-0.5V to +20V (Voltage Referenced to VSS Terminals)
Input Voltage Range, All Inputs	-0.5V to VDD +0.5V
DC Input Current, Any One Input	±10mA
Operating Temperature Range	-55°C to +125°C Package Types D, F, K, H
Storage Temperature Range (TSTG)	-65°C to +150°C
Lead Temperature (During Soldering)	+265°C At Distance 1/16 ± 1/32 Inch (1.59mm ± 0.79mm) from case for 10s Maximum

Reliability Information

Thermal Resistance	θ_{ja}	θ_{jc}
Ceramic DIP Package	80°C/W	20°C/W
Flatpack Package	70°C/W	20°C/W
Maximum Package Power Dissipation (PD) at +125°C		
For $T_A = -55^\circ\text{C}$ to $+100^\circ\text{C}$ (Package Type D, F, K)	500mW	
For $T_A = +100^\circ\text{C}$ to $+125^\circ\text{C}$ (Package Type D, F, K)	Derate Linearity at 12mW/°C to 200mW	
Device Dissipation per Output Transistor	100mW	
For $T_A =$ Full Package Temperature Range (All Package Types)		
Junction Temperature	+175°C	

TABLE 1. DC ELECTRICAL PERFORMANCE CHARACTERISTICS

PARAMETER	SYMBOL	CONDITIONS (NOTE 1)		GROUP A SUBGROUPS	TEMPERATURE	LIMITS		UNITS
						MIN	MAX	
Supply Current	IDD	VDD = 20V, VIN = VDD or GND		1	+25°C	-	10	μA
				2	+125°C	-	1000	μA
		VDD = 18V, VIN = VDD or GND		3	-55°C	-	10	μA
Input Leakage Current	IIL	VIN = VDD or GND	VDD = 20V	1	+25°C	-100	-	nA
				2	+125°C	-1000	-	nA
			VDD = 18V	3	-55°C	-100	-	nA
Input Leakage Current	IIH	VIN = VDD or GND	VDD = 20V	1	+25°C	-	100	nA
				2	+125°C	-	1000	nA
			VDD = 18V	3	-55°C	-	100	nA
Output Voltage	VOL15	VDD = 15V, No Load		1, 2, 3	+25°C, +125°C, -55°C	-	50	mV
Output Voltage	VOH15	VDD = 15V, No Load (Note 3)		1, 2, 3	+25°C, +125°C, -55°C	14.95	-	V
Output Current (Sink)	IOL5	VDD = 5V, VOUT = 0.4V		1	+25°C	0.53	-	mA
Output Current (Sink)	IOL10	VDD = 10V, VOUT = 0.5V		1	+25°C	1.4	-	mA
Output Current (Sink)	IOL15	VDD = 15V, VOUT = 1.5V		1	+25°C	3.5	-	mA
Output Current (Source)	IOH5A	VDD = 5V, VOUT = 4.6V		1	+25°C	-	-0.53	mA
Output Current (Source)	IOH5B	VDD = 5V, VOUT = 2.5V		1	+25°C	-	-1.8	mA
Output Current (Source)	IOH10	VDD = 10V, VOUT = 9.5V		1	+25°C	-	-1.4	mA
Output Current (Source)	IOH15	VDD = 15V, VOUT = 13.5V		1	+25°C	-	-3.5	mA
N Threshold Voltage	VNTH	VDD = 10V, ISS = -10μA		1	+25°C	-2.8	-0.7	V
P Threshold Voltage	VPTH	VSS = 0V, IDD = 10μA		1	+25°C	0.7	2.8	V
Functional	F	VDD = 2.8V, VIN = VDD or GND		7	+25°C	VOH > VDD/2	VOL < VDD/2	V
		VDD = 20V, VIN = VDD or GND		7	+25°C			
		VDD = 18V, VIN = VDD or GND		8A	+125°C			
		VDD = 3V, VIN = VDD or GND		8B	-55°C			
Input Voltage Low (Note 2)	VIL	VDD = 5V, VOH > 4.5V, VOL < 0.5V		1, 2, 3	+25°C, +125°C, -55°C	-	1.5	V
Input Voltage High (Note 2)	VIH	VDD = 5V, VOH > 4.5V, VOL < 0.5V		1, 2, 3	+25°C, +125°C, -55°C	3.5	-	V
Input Voltage Low (Note 2)	VIL	VDD = 15V, VOH > 13.5V, VOL < 1.5V		1, 2, 3	+25°C, +125°C, -55°C	-	4	V
Input Voltage High (Note 2)	VIH	VDD = 15V, VOH > 13.5V, VOL < 1.5V		1, 2, 3	+25°C, +125°C, -55°C	11	-	V

NOTES: 1. All voltages referenced to device GND, 100% testing being implemented. 3. For accuracy, voltage is measured differentially to VDD. Limit is 0.050V max.
2. Go/No Go test with limits applied to inputs.

Specifications CD40102BMS, CD40103BMS

TABLE 2. AC ELECTRICAL PERFORMANCE CHARACTERISTICS

PARAMETER	SYMBOL	CONDITIONS (NOTE 1, 2)	GROUP A SUBGROUPS	TEMPERATURE	LIMITS		UNITS
					MIN	MAX	
Propagation Delay Clock to Output	TPHL1 TPLH1	VDD = 5V, VIN = VDD or GND	9	+25°C	-	600	ns
			10, 11	+125°C, -55°C	-	810	ns
Propagation Delay Carry In/Counter Enable to Output	TPHL2 TPLH2	VDD = 5V, VIN = VDD or GND	9	+25°C	-	400	ns
			10, 11	+125°C, -55°C	-	540	ns
Propagation Delay Asynchronous Preset Enable to Output	TPHL3 TPLH3	VDD = 5V, VIN = VDD or GND	9	+25°C	-	1300	ns
			10, 11	+125°C, -55°C	-	1755	ns
Propagation Delay Clear to Output	TPLH4	VDD = 5V, VIN = VDD or GND	9	+25°C	-	750	ns
			10, 11	+125°C, -55°C	-	1012	ns
Transition Time	TTHL TTLH	VDD = 5V, VIN = VDD or GND	9	+25°C	-	200	ns
			10, 11	+125°C, -55°C	-	270	ns
Maximum Clock Input Frequency	FCL	VDD = 5V, VIN = VDD or GND	9	+25°C	.7	-	MHz
			10, 11	+125°C, -55°C	.52	-	MHz

NOTES:

1. CL = 50pF, RL = 200K, Input TR, TF < 20ns.
2. -55°C and +125°C limits guaranteed, 100% testing being implemented.

TABLE 3. ELECTRICAL PERFORMANCE CHARACTERISTICS

PARAMETER	SYMBOL	CONDITIONS	NOTES	TEMPERATURE	LIMITS		UNITS
					MIN	MAX	
Supply Current	IDD	VDD = 5V, VIN = VDD or GND	1, 2	-55°C, +25°C	-	5	μA
				+125°C	-	150	μA
		VDD = 10V, VIN = VDD or GND	1, 2	-55°C, +25°C	-	10	μA
				+125°C	-	300	μA
		VDD = 15V, VIN = VDD or GND	1, 2	-55°C, +25°C	-	10	μA
				+125°C	-	600	μA
Output Voltage	VOL	VDD = 5V, No Load	1, 2	+25°C, +125°C, -55°C	-	50	mV
Output Voltage	VOL	VDD = 10V, No Load	1, 2	+25°C, +125°C, -55°C	-	50	mV
Output Voltage	VOH	VDD = 5V, No Load	1, 2	+25°C, +125°C, -55°C	4.95	-	V
Output Voltage	VOH	VDD = 10V, No Load	1, 2	+25°C, +125°C, -55°C	9.95	-	V
Output Current (Sink)	IOL5	VDD = 5V, VOUT = 0.4V	1, 2	+125°C	0.36	-	mA
				-55°C	0.64	-	mA
Output Current (Sink)	IOL10	VDD = 10V, VOUT = 0.5V	1, 2	+125°C	0.9	-	mA
				-55°C	1.6	-	mA
Output Current (Sink)	IOL15	VDD = 15V, VOUT = 1.5V	1, 2	+125°C	2.4	-	mA
				-55°C	4.2	-	mA
Output Current (Source)	IOH5A	VDD = 5V, VOUT = 4.6V	1, 2	+125°C	-	-0.36	mA
				-55°C	-	-0.64	mA
Output Current (Source)	IOH5B	VDD = 5V, VOUT = 2.5V	1, 2	+125°C	-	-1.15	mA
				-55°C	-	-2.0	mA

Specifications CD40102BMS, CD40103BMS

TABLE 3. ELECTRICAL PERFORMANCE CHARACTERISTICS (Continued)

PARAMETER	SYMBOL	CONDITIONS	NOTES	TEMPERATURE	LIMITS		UNITS
					MIN	MAX	
Output Current (Source)	IOH10	VDD = 10V, VOUT = 9.5V	1, 2	+125°C	-	-0.9	mA
				-55°C	-	-1.6	mA
Output Current (Source)	IOH15	VDD = 15V, VOUT = 13.5V	1, 2	+125°C	-	-2.4	mA
				-55°C	-	-4.2	mA
Input Voltage Low	VIL	VDD = 10V, VOH > 9V, VOL < 1V	1, 2	+25°C, +125°C, -55°C	-	3	V
Input Voltage High	VIH	VDD = 10V, VOH > 9V, VOL < 1V	1, 2	+25°C, +125°C, -55°C	7	-	V
Propagation Delay Clock to Output	TPHL1 TPLH1	VDD = 10V	1, 2, 3	+25°C	-	260	ns
		VDD = 15V	1, 2, 3	+25°C	-	190	ns
Propagation Delay Carry In/Counter Enable to Output	TPHL2 TPLH2	VDD = 10V	1, 2, 3	+25°C	-	180	ns
		VDD = 15V	1, 2, 3	+25°C	-	130	ns
Propagation Delay Asynchronous Preset En- able to Output	TPHL3 TPLH3	VDD = 10V	1, 2, 3	+25°C	-	600	ns
		VDD = 15V	1, 2, 3	+25°C	-	400	ns
Propagation Delay Clear to Output	TPLH4	VDD = 10V	1, 2, 3	+25°C	-	360	ns
		VDD = 15V	1, 2, 3	+25°C	-	200	ns
Transition Time	TTHL1 TTLH1	VDD = 10V	1, 2, 3	+25°C	-	100	ns
		VDD = 15V	1, 2, 3	+25°C	-	80	ns
Maximum Clock Input Frequency	FCL	VDD = 10V	1, 2	+25°C	1.8	-	MHz
		VDD = 15V	1, 2	+25°C	2.4	-	MHz
Minimum \overline{SPE} Setup Time	TSU	VDD = 5V	1, 2, 3	+25°C	-	280	ns
		VDD = 10V	1, 2, 3	+25°C	-	140	ns
		VDD = 15V	1, 2, 3	+25°C	-	100	ns
Minimum $\overline{CI}/\overline{CE}$ Setup Time	TSU	VDD = 5V	1, 2, 3	+25°C	-	500	ns
		VDD = 10V	1, 2, 3	+25°C	-	250	ns
		VDD = 15V	1, 2, 3	+25°C	-	150	ns
Minimum Clock Pulse Width	TW	VDD = 5V	1, 2, 3	+25°C	-	300	ns
		VDD = 10V	1, 2, 3	+25°C	-	180	ns
		VDD = 15V	1, 2, 3	+25°C	-	80	ns
Minimum \overline{APE} Pulse Width	TW	VDD = 5V	1, 2, 3	+25°C	-	360	ns
		VDD = 10V	1, 2, 3	+25°C	-	160	ns
		VDD = 15V	1, 2, 3	+25°C	-	120	ns
Minimum JAM Setup Time (Synchronous Pre- setting)	TSU	VDD = 5V	1, 2, 3	+25°C	-	200	ns
		VDD = 10V	1, 2, 3	+25°C	-	80	ns
		VDD = 15V	1, 2, 3	+25°C	-	60	ns
Minimum \overline{APE} Removal Time	TREM	VDD = 5V	1, 2, 3	+25°C	-	220	ns
		VDD = 10V	1, 2, 3	+25°C	-	100	ns
		VDD = 15V	1, 2, 3	+25°C	-	70	ns
Minimum \overline{CLR} Pulse Width	TW	VDD = 5V	1, 2, 3	+25°C	-	320	ns
		VDD = 10V	1, 2, 3	+25°C	-	160	ns
		VDD = 15V	1, 2, 3	+25°C	-	100	ns

Specifications CD40102BMS, CD40103BMS

TABLE 3. ELECTRICAL PERFORMANCE CHARACTERISTICS (Continued)

PARAMETER	SYMBOL	CONDITIONS	NOTES	TEMPERATURE	LIMITS		UNITS
					MIN	MAX	
Input Capacitance	CIN	Any Input	1, 2	+25°C	-	7.5	pF

NOTES:

1. All voltages referenced to device GND.
2. The parameters listed on Table 3 are controlled via design or process and are not directly tested. These parameters are characterized on initial design release and upon design changes which would affect these characteristics.
3. CL = 50pF, RL = 200K, Input TR, TF < 20ns.

TABLE 4. POST IRRADIATION ELECTRICAL PERFORMANCE CHARACTERISTICS

PARAMETER	SYMBOL	CONDITIONS	NOTES	TEMPERATURE	LIMITS		UNITS
					MIN	MAX	
Supply Current	IDD	VDD = 20V, VIN = VDD or GND	1, 4	+25°C	-	25	μA
N Threshold Voltage	VNTH	VDD = 10V, ISS = -10μA	1, 4	+25°C	-2.8	-0.2	V
N Threshold Voltage Delta	ΔVTN	VDD = 10V, ISS = -10μA	1, 4	+25°C	-	±1	V
P Threshold Voltage	VTP	VSS = 0V, IDD = 10μA	1, 4	+25°C	0.2	2.8	V
P Threshold Voltage Delta	ΔVTP	VSS = 0V, IDD = 10μA	1, 4	+25°C	-	±1	V
Functional	F	VDD = 18V, VIN = VDD or GND	1	+25°C	VOH > VDD/2	VOL < VDD/2	V
		VDD = 3V, VIN = VDD or GND					
Propagation Delay Time	TPHL TPLH	VDD = 5V	1, 2, 3, 4	+25°C	-	1.35 x +25°C Limit	ns

- NOTES: 1. All voltages referenced to device GND. 2. CL = 50pF, RL = 200K, Input TR, TF < 20ns. 3. See Table 2 for +25°C limit. 4. Read and Record

TABLE 5. BURN-IN AND LIFE TEST DELTA PARAMETERS +25°C

PARAMETER	SYMBOL	DELTA LIMIT
Supply Current - MSI-2	IDD	± 1.0μA
Output Current (Sink)	IOL5	± 20% x Pre-Test Reading
Output Current (Source)	IOH5A	± 20% x Pre-Test Reading

TABLE 6. APPLICABLE SUBGROUPS

CONFORMANCE GROUP	MIL-STD-883 METHOD	GROUP A SUBGROUPS	READ AND RECORD
Initial Test (Pre Burn-In)	100% 5004	1, 7, 9	IDD, IOL5, IOH5A
Interim Test 1 (Post Burn-In)	100% 5004	1, 7, 9	IDD, IOL5, IOH5A
Interim Test 2 (Post Burn-In)	100% 5004	1, 7, 9	IDD, IOL5, IOH5A
PDA (Note 1)	100% 5004	1, 7, 9, Deltas	
Interim Test 3 (Post Burn-In)	100% 5004	1, 7, 9	IDD, IOL5, IOH5A
PDA (Note 1)	100% 5004	1, 7, 9, Deltas	
Final Test	100% 5004	2, 3, 8A, 8B, 10, 11	
Group A	Sample 5005	1, 2, 3, 7, 8A, 8B, 9, 10, 11	
Group B	Subgroup B-5	Sample 5005	Subgroups 1, 2, 3, 9, 10, 11
	Subgroup B-6	Sample 5005	1, 7, 9

Specifications CD40102BMS, CD40103BMS

TABLE 6. APPLICABLE SUBGROUPS (Continued)

CONFORMANCE GROUP	MIL-STD-883 METHOD	GROUP A SUBGROUPS	READ AND RECORD
Group D	Sample 5005	1, 2, 3, 8A, 8B, 9	Subgroups 1, 2 3

NOTE: 1. 5% Parametric, 3% Functional; Cumulative for Static 1 and 2.

TABLE 7. TOTAL DOSE IRRADIATION

CONFORMANCE GROUPS	MIL-STD-883 METHOD	TEST		READ AND RECORD	
		PRE-IRRAD	POST-IRRAD	PRE-IRRAD	POST-IRRAD
Group E Subgroup 2	5005	1, 7, 9	Table 4	1, 9	Table 4

TABLE 8. BURN-IN AND IRRADIATION TEST CONNECTIONS

FUNCTION	OPEN	GROUND	VDD	9V ± -0.5V	OSCILLATOR	
					50kHz	25kHz
PART NUMBER CD40102BMS, CD40103BMS						
Static Burn-In 1 Note 1	14	1 - 13, 15	16			
Static Burn-In 2 Note 1	14	8	1 - 7, 9 - 13, 15, 16			
Dynamic Burn-In Note 1	-	3, 8, 15	2, 16	14	1, 4, 6, 11, 13	5, 7, 9, 10, 12
Irradiation Note 2	-					

NOTES:

1. Each pin except VDD and GND will have a series resistor of 10K ± 5%, VDD = 18V ± 0.5V
2. Each pin except VDD and GND will have a series resistor of 47K ± 5%; Group E, Subgroup 2, sample size is 4 dice/wafer, 0 failures, VDD = 10V ± 0.5V

Functional Diagram

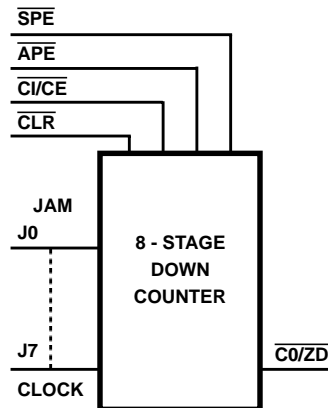

CD40102BMS, CD40103BMS

Logic Diagrams

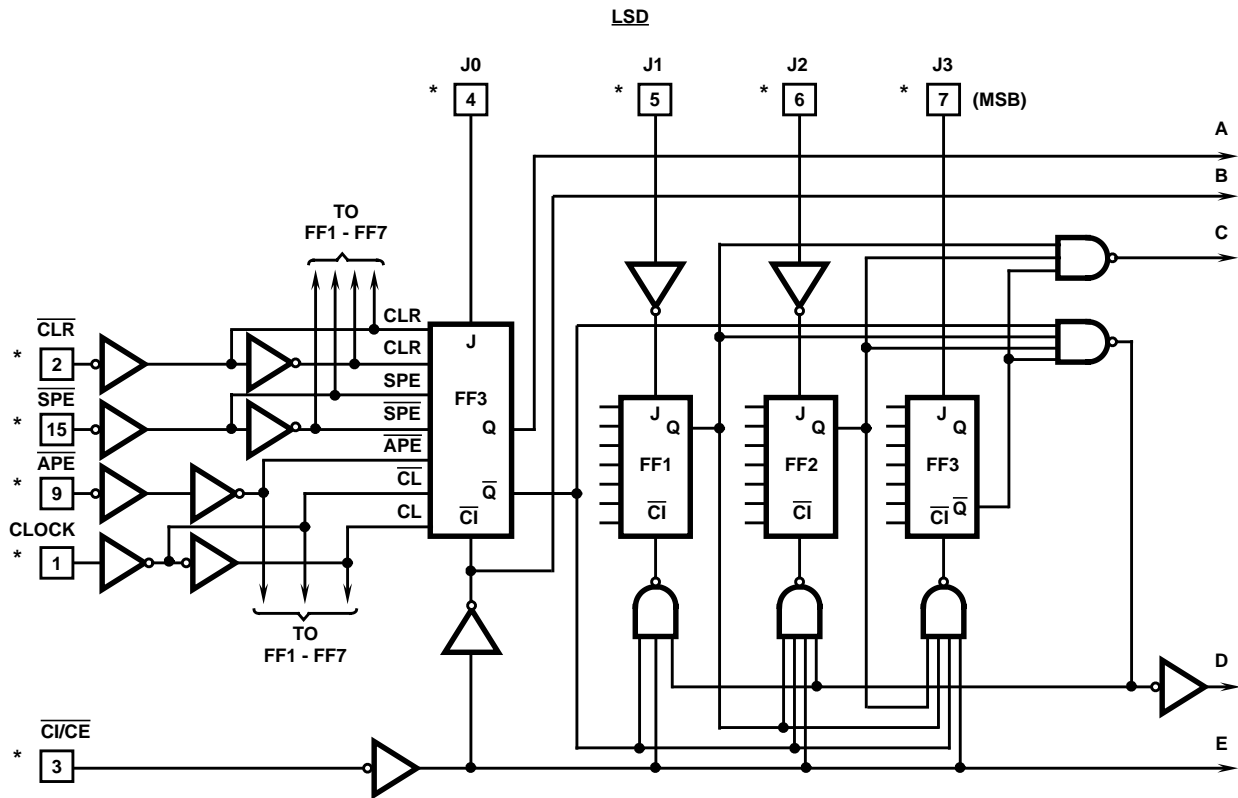

FIGURE 1. LOGIC DIAGRAM FOR CD40102BMS

CD40102BMS, CD40103BMS

TRUTH TABLE

CONTROL INPUTS				PRESET MODE	ACTION
$\overline{\text{CLR}}$	$\overline{\text{APE}}$	$\overline{\text{SPE}}$	$\overline{\text{C/CE}}$		
1	1	1	1	Synchronous	Inhibit Counter
1	1	1	0		Count Down*
1	1	0	X		Preset on next positive clock transition
1	0	X	X	Asynchronous	Preset Asynchronously
0	X	X	X		Clear to maximum count

NOTES:

1. 0 = Low Level
1 = High Level
X = Don't Care
 2. Clock connected to clock input
 3. Synchronous operation: changes occur on negative-to-positive clock transitions
 4. JAM inputs: CD40102BMS;
MSD = J7, J6, J5, J4, (J7 is MSB)
LSD = J3, J2, J1, J0 (J3 is MSB)
CD40103BMS Binary;
MBS = J7, LSB = J0
- *At zero count, the counters will jump to the maximum count on the next clock transition to "High"

Typical Performance Characteristics

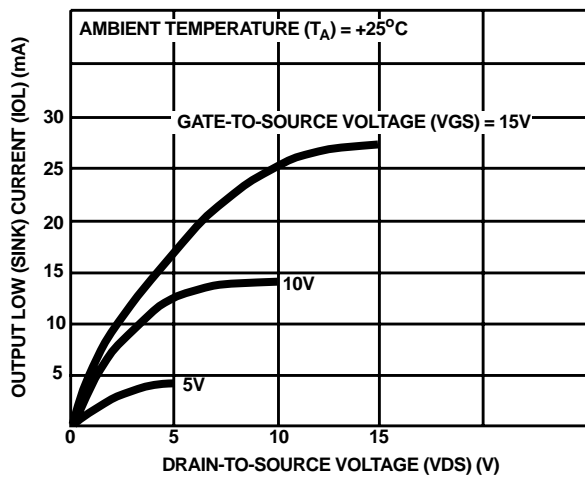

FIGURE 3. TYPICAL OUTPUT LOW (SINK) CURRENT CHARACTERISTICS

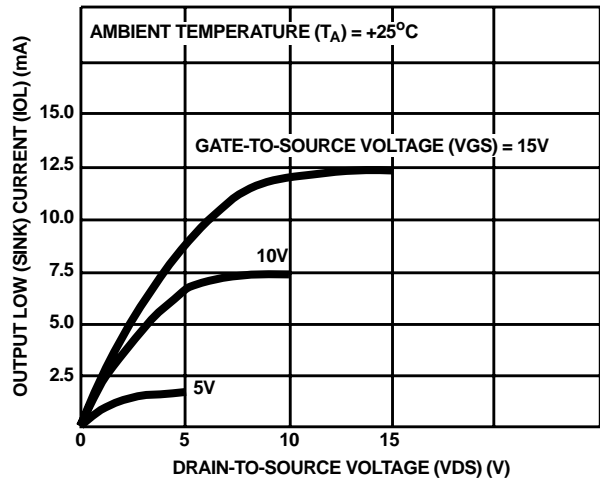

FIGURE 4. MINIMUM OUTPUT LOW (SINK) CURRENT CHARACTERISTICS

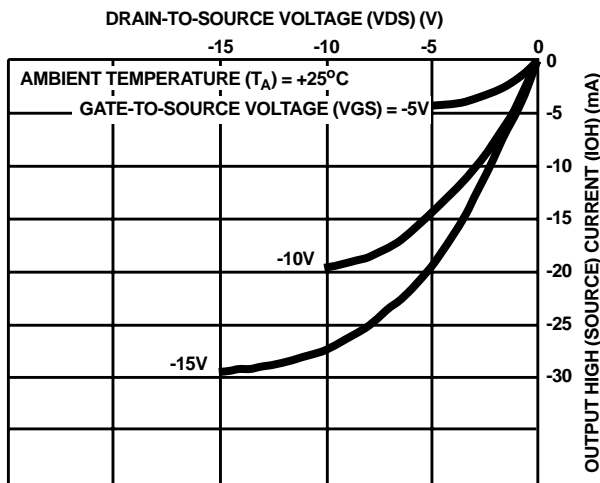

FIGURE 5. TYPICAL OUTPUT HIGH (SOURCE) CURRENT CHARACTERISTICS

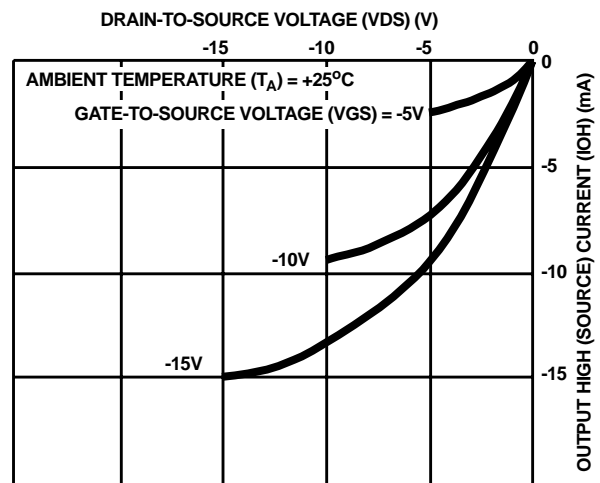

FIGURE 6. MINIMUM OUTPUT HIGH (SOURCE) CURRENT CHARACTERISTICS

Typical Performance Characteristics (Continued)

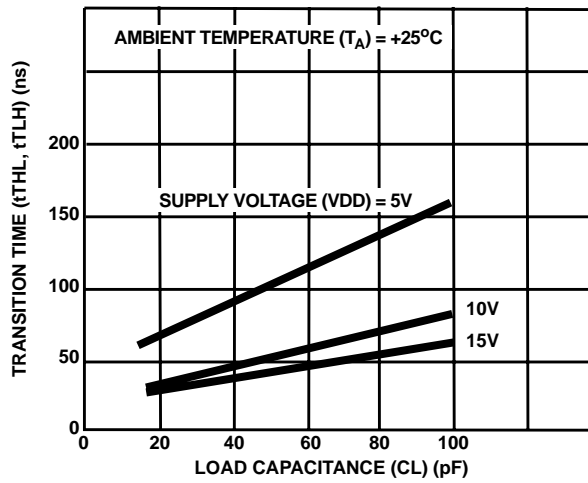

FIGURE 7. TYPICAL TRANSITION TIME AS A FUNCTION OF LOAD CAPACITANCE

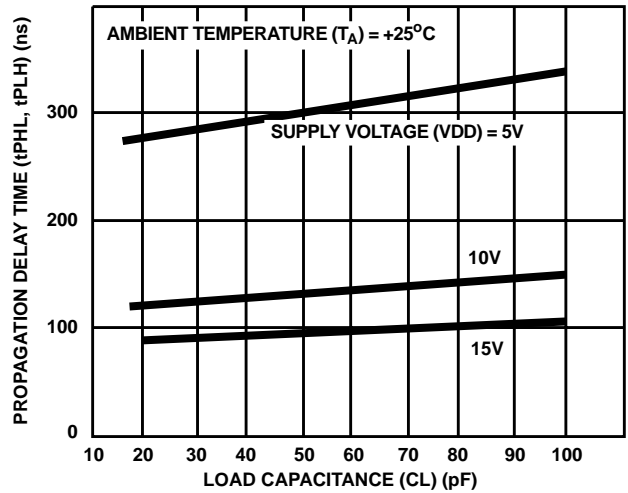

FIGURE 8. TYPICAL PROPAGATION DELAY TIME AS A FUNCTION OF LOAD CAPACITANCE (CLOCK TO $\overline{CO/ZD}$)

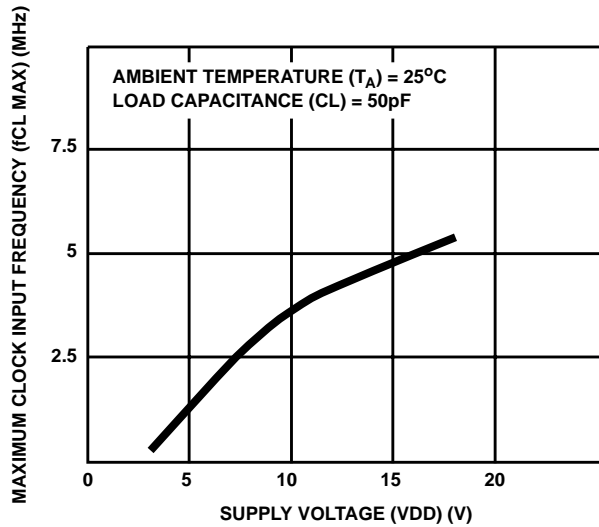

FIGURE 9. TYPICAL MAXIMUM CLOCK INPUT FREQUENCY AS A FUNCTION OF SUPPLY VOLTAGE

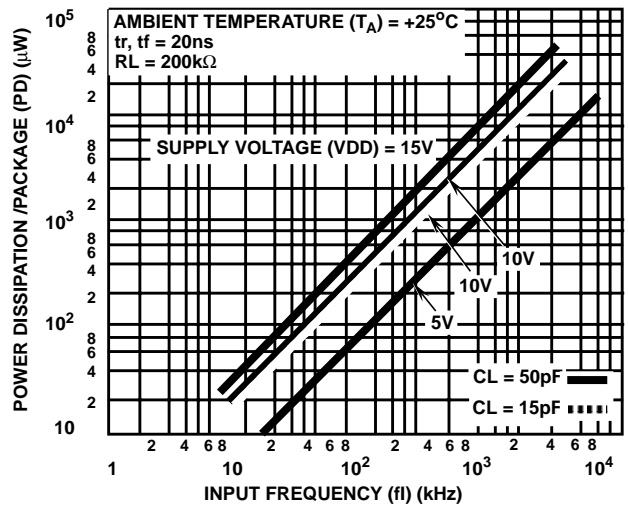

FIGURE 10. TYPICAL DYNAMIC POWER DISSIPATION AS A FUNCTION OF FREQUENCY

CD40102BMS, CD40103BMS

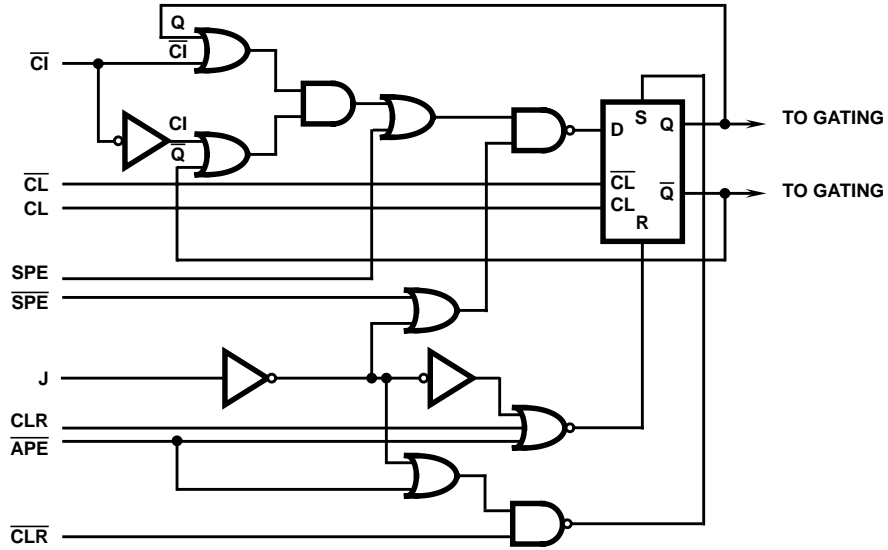

FIGURE 11. DETAIL LOGIC DIAGRAM FOR FLIP-FLOPS, FF0 - FF7, USED IN LOGIC DIAGRAMS FOR CD40102BMS AND CD40103BMS

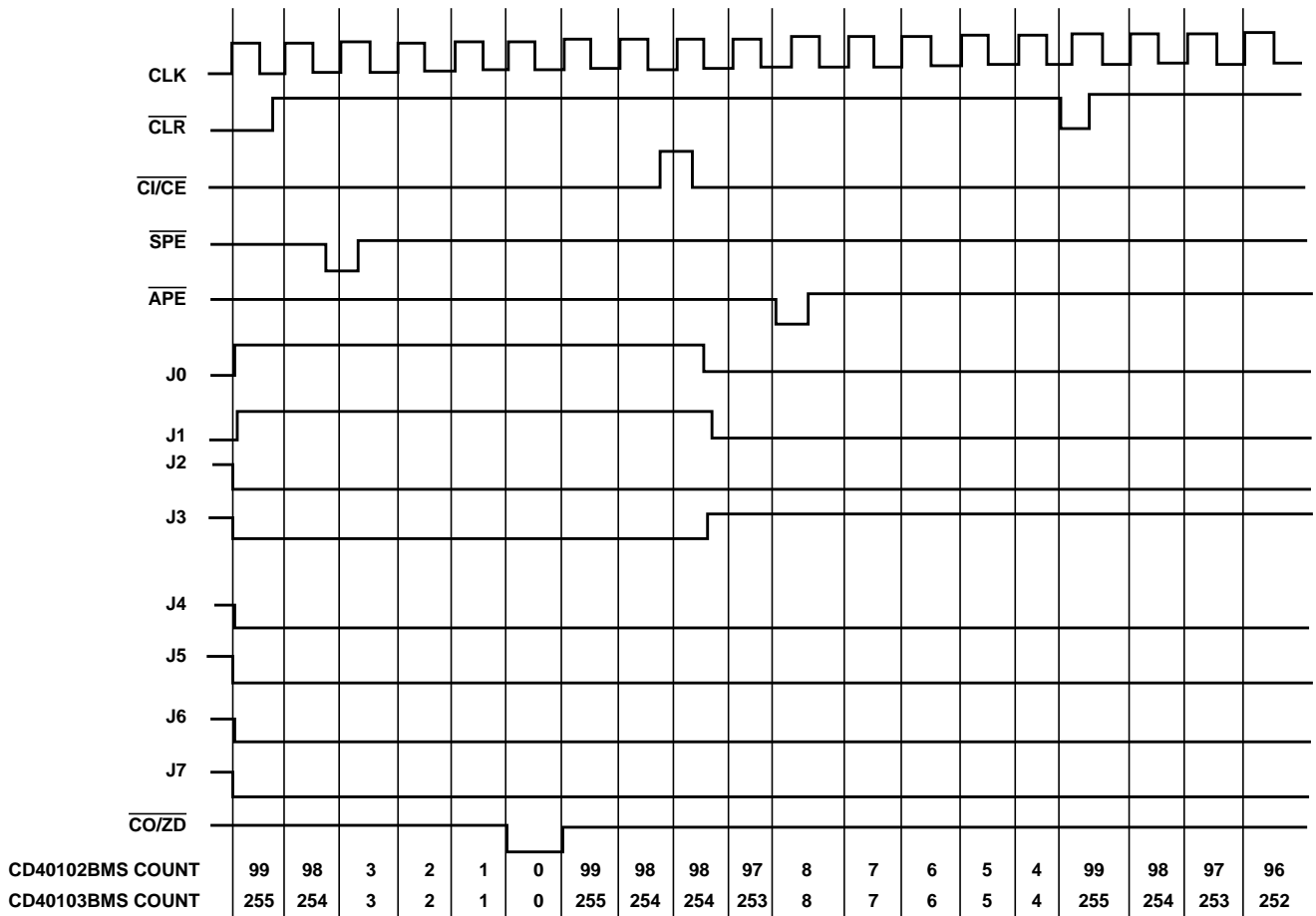

FIGURE 12. TIMING DIAGRAM FOR CD40102BMS AND CD40103BMS

CD40102BMS, CD40103BMS

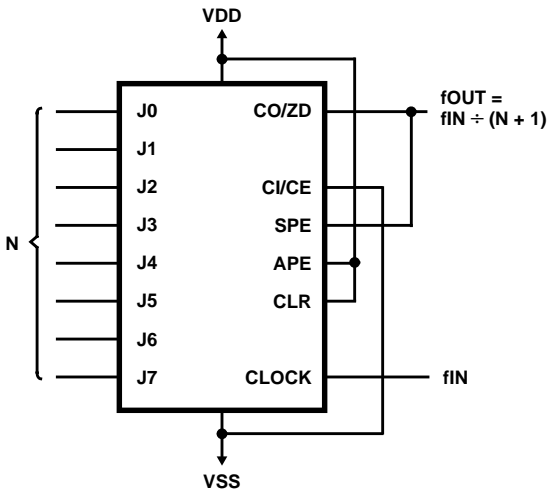

FIGURE 13. DIVIDE-BY- "N" COUNTER

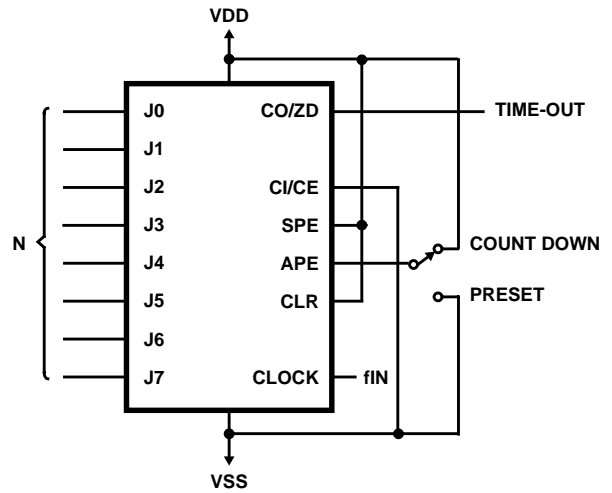

FIGURE 14. PROGRAMMABLE TIMER

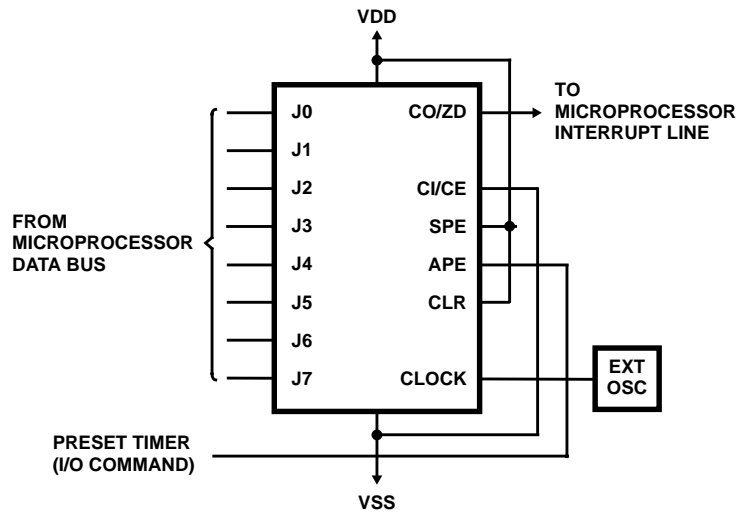
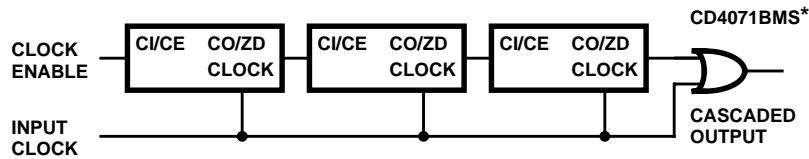

FIGURE 15. MICROPROCESSOR INTERRUPT TIMER



*An output spike (160ns at VDD = 5V) occurs whenever two or more devices are cascaded in the parallel-clocked mode because the clock-to-carry out delay is greater than the carry-in-to-carry out delay. This spike is eliminated by gating the output of the last device with the clock as shown.

FIGURE 16. SYNCHRONOUS CASCADING

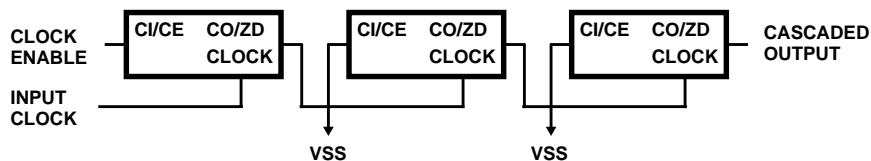
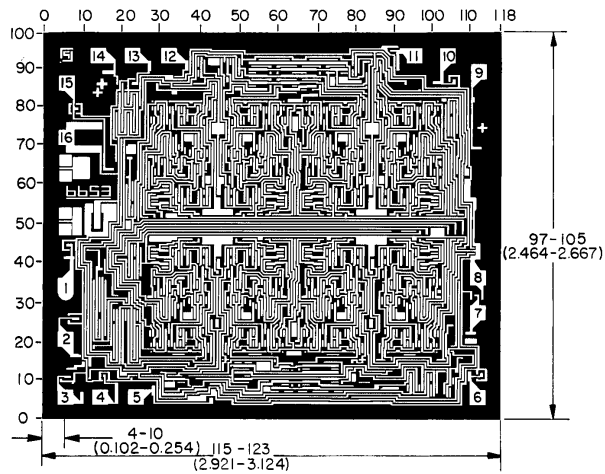

FIGURE 17. RIPPLE CASCADING

CD40102BMS, CD40103BMS

Chip Dimensions and Pad Layouts



CD40102BMS

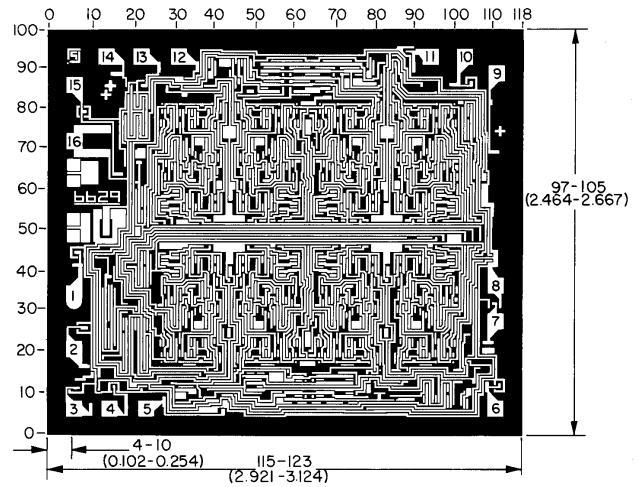

CD40103BMS

Dimensions in parenthesis are in millimeters and are derived from the basic inch dimensions as indicated. Grid graduations are in mils (10-3 inch).

METALLIZATION: Thickness: $11\text{k}\text{\AA} - 14\text{k}\text{\AA}$, AL.

PASSIVATION: $10.4\text{k}\text{\AA} - 15.6\text{k}\text{\AA}$, Silane

BOND PADS: 0.004 inches X 0.004 inches MIN

DIE THICKNESS: 0.0198 inches - 0.0218 inches

All Intersil semiconductor products are manufactured, assembled and tested under **ISO9000** quality systems certification.

Intersil products are sold by description only. Intersil Corporation reserves the right to make changes in circuit design and/or specifications at any time without notice. Accordingly, the reader is cautioned to verify that data sheets are current before placing orders. Information furnished by Intersil is believed to be accurate and reliable. However, no responsibility is assumed by Intersil or its subsidiaries for its use; nor for any infringements of patents or other rights of third parties which may result from its use. No license is granted by implication or otherwise under any patent or patent rights of Intersil or its subsidiaries.

For information regarding Intersil Corporation and its products, see web site <http://www.intersil.com>

Sales Office Headquarters

NORTH AMERICA

Intersil Corporation
P. O. Box 883, Mail Stop 53-204
Melbourne, FL 32902
TEL: (321) 724-7000
FAX: (321) 724-7240

EUROPE

Intersil SA
Mercure Center
100, Rue de la Fusee
1130 Brussels, Belgium
TEL: (32) 2.724.2111
FAX: (32) 2.724.22.05

ASIA

Intersil (Taiwan) Ltd.
Taiwan Limited
7F-6, No. 101 Fu Hsing North Road
Taipei, Taiwan
Republic of China
TEL: (886) 2 2716 9310
FAX: (886) 2 2715 3029