

March 1997

## 32-Word x 8-Bit Static RAM

### Features

- **Fast Access Time**
  - $V_{DD} = 5V$  ..... **710ns**
  - $V_{DD} = 10V$  ..... **320ns**
- **No Precharge or Clock Required**

### Description

The CDP1824 and CDP1824C are 32-word x 8-bit fully static CMOS random-access memories for use in CDP-1800 series microprocessor systems. These parts are compatible with the CDP1802 microprocessor and will interface directly without additional components.

The CDP1824 is fully decoded and does not require a pre-charge or clocking signal for proper operation. It has common input and output and is operated from a single voltage supply. The MRD signal (output disable control) enables the three-state output drivers, and overrides the MWR signal. A CS input is provided for memory expansion.

The CDP1824C is functionally identical to the CDP1824. The CDP1824 has an operating range of 4V to 10.5V, and the CDP1824C has an operating voltage range of 4V to 6.5V. The CDP1824 and CDP1824C are supplied in 18 lead hermetic dual-in-line ceramic packages (D suffix), and in 18 lead dual-in-line plastic packages (E suffix).

### Ordering Information

5V	10V	PACKAGE	TEMPERATURE RANGE	PKG. NO.
CDP1824CE	CDP1824E	PDIP	-40°C to +85°C	E18.3
CDP1824CEX	CDP1824EX	Burn-In		E18.3
CDP1824CD	CDP1824D	SBDIP	-40°C to +85°C	D18.3

### Pinout

CDP1824, CDP1824C (PDIP, SBDIP)  
TOP VIEW

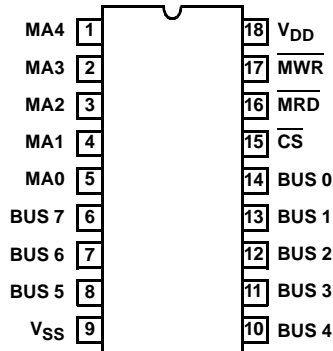

OPERATIONAL MODES

FUNCTION	CS	MRD	MWR	DATA PINS STATUS
READ	0	0	X	Output: High/Low Dependent on Data
WRITE	0	1	0	Input: Output Disabled
Not Selected	1	X	X	Output Disabled: High-Impedance State
Standby	0	1	1	Output Disabled: High-Impedance State

Logic 1 = High   Logic 0 = Low   X = Don't Care

# CDP1824, CDP1824C

## Absolute Maximum Ratings

DC Supply Voltage Range, ( $V_{DD}$ ) (All Voltages Referenced to $V_{SS}$ Terminal)	
CDP1824	-0.5V to +11V
CDP1824C	-0.5V to +7V
Input Voltage Range, All Inputs	-0.5V to $V_{DD} + 0.5V$
DC Input Current, Any One Input	$\pm 10mA$
Operating Temperature Range ( $T_A$ )	
Package Type D	-55°C to +125°C
Package Type E	-40°C to +85°C

## Thermal Information

Thermal Resistance (Typical)	$\theta_{JA}$ (°C/W)	$\theta_{JC}$ (°C/W)
SBDIP Package	75	20
PDIP Package	75	N/A
Storage Temperature Range ( $T_{STG}$ )	-65°C to +150°C	
Lead Temperature (During Soldering)		
At distance 1/16 $\pm$ 1/32 In. (1.59 $\pm$ 0.79mm)		
from case for 10s max.	+265°C	

## Recommended Operating Conditions

At  $T_A$  = Full Package Temperature Range. For maximum reliability, operating conditions should be selected so that operation is always within the following ranges:

PARAMETER	CONDITION $V_{DD}$ (V)	LIMITS				UNITS
		CDP1824D		CDP1824CD		
		MIN	MAX	MIN	MAX	
Supply Voltage Range	-	4	10.5	4	6.5	V
Recommended Input Voltage Range	-	$V_{SS}$	$V_{DD}$	$V_{SS}$	$V_{DD}$	V
Input Signal Rise or Fall Time (Note 1)	5	-	5	-	5	$\mu s$
$t_R, t_F$	10	-	2	-	-	$\mu s$

NOTE:

- Input signal rise or fall times longer than these maxima can cause loss of stored data in either the selected or deselected mode.

## Static Electrical Specifications

At  $T_A$  = -40°C to +85°C, Except as Noted:

PARAMETER	SYMBOL	CONDITIONS			LIMITS						UNITS
		$V_O$ (V)	$V_{IN}$ (V)	$V_{DD}$ (V)	CDP1824			CDP1824C			
					MIN	(NOTE 1) TYP	MAX	MIN	(NOTE 1) TYP	MAX	
Quiescent Device Current	$I_{DD}$	-	-	5	-	25	50	-	100	200	$\mu A$
		-	-	10	-	250	500	-	-	-	$\mu A$
Output Low (Sink) Current	$I_{OL}$	0.4	0, 5	5	1.8	2.2	-	1.8	2.2	-	mA
		0.5	0, 10	10	3.6	4.5	-	-	-	-	mA
Output High (Source) Current	$I_{OH}$	4.6	0, 5	5	-0.9	-1.1	-	-0.9	-1.1	-	mA
		9.5	0, 10	10	-1.8	-2.2	-	-	-	-	mA
Output Voltage Low-Level	$V_{OL}$	-	0, 5	5	-	0	0.1	-	0	0.1	V
		-	0, 10	10	-	0	0.1	-	-	-	V
Output Voltage High-Level	$V_{OH}$	-	0, 5	5	4.9	5	-	4.9	5	-	V
		-	0, 10	10	9.9	10	-	-	-	-	V
Input Low Voltage	$V_{IL}$	0.5, 4.5	-	5	-	-	1.5	-	-	1.5	V
		1.9	-	10	-	-	3	-	-	-	V
Input High Voltage	$V_{IH}$	0.5, 9.5	-	5	3.5	-	-	3.5	-	-	V
		1.9	-	10	7	-	-	-	-	-	V
Input Leakage Current	$I_{IN}$	Any Input	0, 5	5	-	$\pm 0.1$	$\pm 1$	-	$\pm 0.1$	$\pm 1$	$\mu A$
			0, 10	10	-	$\pm 0.1$	$\pm 1$	-	-	-	$\mu A$
Operating Current (Note 2)	$I_{DD1}$	-	0, 5	5	-	4	8	-	4	8	mA
		-	0, 10	10	-	8	16	-	-	-	mA

## CDP1824, CDP1824C

### Static Electrical Specifications At $T_A = -40^{\circ}\text{C}$ to $+85^{\circ}\text{C}$ , Except as Noted: (Continued)

PARAMETER	SYMBOL	CONDITIONS			LIMITS						UNITS
		$V_O$ (V)	$V_{IN}$ (V)	$V_{DD}$ (V)	CDP1824			CDP1824C			
					MIN	(NOTE 1) TYP	MAX	MIN	(NOTE 1) TYP	MAX	
Three-State Output Leakage Current	$I_{OUT}$	0, 5	0, 5	5	-	$\pm 0.2$	$\pm 2.0$	-	$\pm 0.2$	$\pm 2$	$\mu\text{A}$
		0, 10	0, 10	10	-	$\pm 0.2$	$\pm 2.0$	-	-	-	$\mu\text{A}$
Input Capacitance	$C_{IN}$	-	-	-	-	5	7.5	-	5	7.5	pF
Output Capacitance	$C_{OUT}$	-	-	-	-	10	15	-	10	15	pF

**NOTES:**

1. Typical values are for  $T_A = +25^{\circ}\text{C}$  and nominal  $V_{DD}$ .
2. Outputs open circuited; Cycle time =  $1\mu\text{s}$ .

### Dynamic Electrical Specifications at $T_A = -40^{\circ}\text{C}$ to $+85^{\circ}\text{C}$ , $V_{DD} \pm 5\%$ , Input $t_R, t_F = 10\text{ns}$ , $C_L = 50\text{pF}$ , $R_L = 200\text{k}\Omega$ ; See Figure 1

PARAMETER	SYMBOL	TEST CONDITIONS	LIMITS						UNITS
			CDP1824D, CDP1824E			CDP1824CD, CDP1824CE			
			(NOTE 1) MIN	(NOTE 2) TYP	MAX	(NOTE 1) MIN	(NOTE 2) TYP	MAX	
<b>READ OPERATION</b>									
Access Time From Address Change	$t_{AA}$	5	-	400	710	-	400	710	ns
		10	-	200	320	-	-	-	ns
Access Time From Chip Select	$t_{DOA}$	5	-	300	710	-	300	710	ns
		10	-	150	320	-	-	-	ns
Output Active From $\overline{\text{MRD}}$	$t_{AM}$	5	-	300	710	-	300	710	ns
		10	-	150	320	-	-	-	ns

**NOTES:**

1. Time required by a limit device to allow for the indicated function.
2. Time required by a typical device to allow for the indicated function. Typical values are for  $T_A = +25^{\circ}\text{C}$  and nominal  $V_{DD}$ .

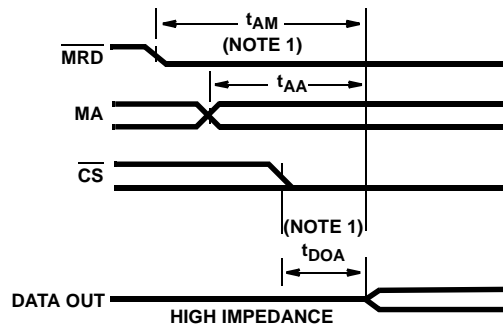

**NOTES:**

1. Minimum timing for valid data output longer times will initiate an earlier, but invalid output.

**FIGURE 1. READ CYCLE TIMING DIAGRAMS**

## CDP1824, CDP1824C

**Dynamic Electrical Specifications** at  $T_A = -40^{\circ}\text{C}$  to  $+85^{\circ}\text{C}$ ,  $V_{DD} \pm 5\%$ , Input  $t_R, t_F = 10\text{ns}$ ,  $C_L = 50\text{pF}$ ,  $R_L = 200\text{k}\Omega$ ; See Figure 2

PARAMETER	SYMBOL	TEST CONDITIONS $V_{DD}$ (V)	LIMITS						UNITS
			CDP1824D, CDP1824E			CDP1824CD, CDP1824CE			
			(NOTE 1) MIN	(NOTE 2) TYP	MAX	(NOTE 1) MIN	(NOTE 2) TYP	MAX	
<b>WRITE OPERATION</b>									
Write Pulse Width	$t_{WRW}$	5	390	200	-	390	200	-	ns
		10	180	150	-	-	-	-	ns
Data Setup Time	$t_{DS}$	5	390	100	-	390	100	-	ns
		10	180	50	-	-	-	-	ns
Data Hold Time	$t_{DH}$	5	70	40	-	70	40	-	ns
		10	35	20	-	-	-	-	ns
Chip Select Setup Time	$t_{CS}$	5	425	210	-	425	210	-	ns
		10	215	110	-	-	-	-	ns
Address Setup Time	$t_{AS}$	5	640	500	-	640	500	-	ns
		10	390	300	-	-	-	-	ns

NOTES:

1. Time required by a limit device to allow for the indicated function.
2. Time required by a typical device to allow for the indicated function. Typical values are for  $T_A = +25^{\circ}\text{C}$  and nominal  $V_{DD}$ .

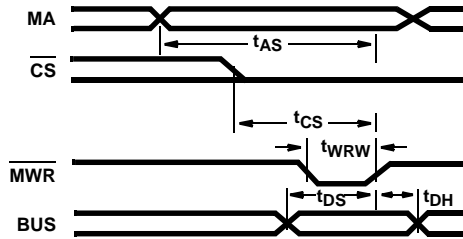
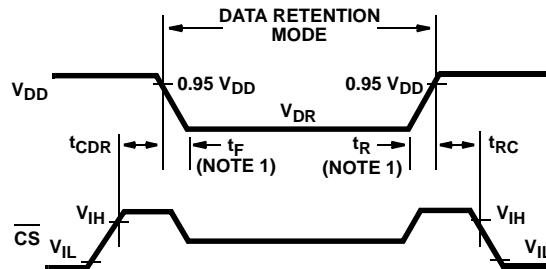

FIGURE 2. WRITE CYCLE TIMING DIAGRAM



NOTE:  $t_R, t_F > 1\mu\text{s}$ .

FIGURE 3. LOW  $V_{DD}$  DATA RETENTION WAVEFORMS AND TIMING DIAGRAM

# CDP1824, CDP1824C

## Data Retention Specifications at $T_A = -40^{\circ}\text{C}$ to $+85^{\circ}\text{C}$ ; See Figure 3

PARAMETER	SYMBOL	TEST CONDITIONS	$V_{DD}$ (V)	LIMITS				UNITS
				CDP1824		CDP1824C		
				MIN	MAX	MIN	MAX	
Data Retention Voltage	$V_{DR}$		-	2.5	-	2.5	-	V
Data Retention Quiescent Current	$I_{DD}$	$V_{DR} = 2.5\text{V}$	-	-	10	-	40	$\mu\text{A}$
Chip Deselect to Data Retention Time	$t_{CDR}$	$V_{DR} = 2.5\text{V}$	5	600	-	600	-	ns
			10	300	-	-	-	ns
Recovery to Normal Operation Time	$t_{RC}$	$V_{DR} = 2.5\text{V}$	5	600	-	600	-	ns
			10	300	-	-	-	ns

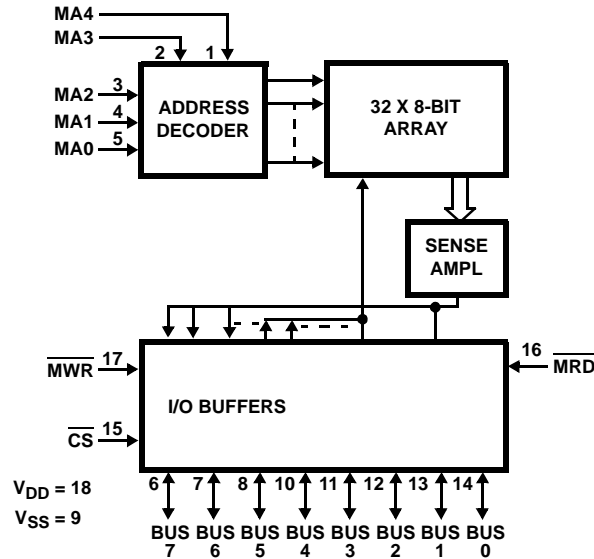

FIGURE 4. FUNCTIONAL DIAGRAM

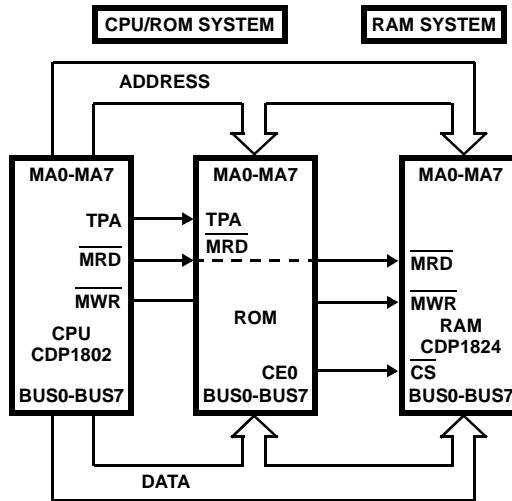

FIGURE 5. CDP1824 (128 X 8) MINIMUM SYSTEM (128 X 8)

All Intersil U.S. products are manufactured, assembled and tested utilizing ISO9000 quality systems. Intersil Corporation's quality certifications can be viewed at [www.intersil.com/design/quality](http://www.intersil.com/design/quality)

*Intersil products are sold by description only. Intersil Corporation reserves the right to make changes in circuit design, software and/or specifications at any time without notice. Accordingly, the reader is cautioned to verify that data sheets are current before placing orders. Information furnished by Intersil is believed to be accurate and reliable. However, no responsibility is assumed by Intersil or its subsidiaries for its use, nor for any infringements of patents or other rights of third parties which may result from its use. No license is granted by implication or otherwise under any patent or patent rights of Intersil or its subsidiaries.*

For information regarding Intersil Corporation and its products, see [www.intersil.com](http://www.intersil.com)