

## CLC012 Adaptive Cable Equalizer for ITU-T G.703 Data Recovery

Check for Samples: [CLC012](#)

### FEATURES

- Automatic equalization of coaxial and twisted pair cables
- Loss of Signal detect and output mute
- Output eye monitor
- Single supply operation: +5V or –5.2V
- Single-ended or differential input
- Low cost

### APPLICATIONS

- ITU-T G.703 serial data recovery
- Serial digital data routing and distribution
- Serial digital data equalization and reception
- Data recovery equalization: ATM, CAD networks, medical, set top terminals, industrial video networks

### DESCRIPTION

National's CLC012 adaptive cable equalizer is a low-cost monolithic solution for equalizing data transmitted over cable (or any media with similar dispersive loss characteristics). The CLC012 simplifies the task of high-speed data recovery with a one-chip solution and a minimal number of external components. The equalizer automatically adapts to equalize any cable length from zero meters to lengths that attenuate the signal by 40 dB at 200 MHz. This corresponds to 300 meters of Belden 8281 or 120 meters of Category 5 UTP (unshielded twisted pair).

The CLC012 provides superior jitter performance: 180ps<sub>pp</sub> for 270 Mbps data that has passed through 200 meters of Belden 8281 cable. This exceptional performance provides wide error margin in digital data links. The equalizer operates on a single supply with a power consumption of only 290 mW. The small 14-pin SOIC package allows for high-density placement of components for multi-channel applications such as routers. The equalizer operates over a wide range of data rates from less than 50 Mbps to rates in excess of 650 Mbps.

The equalizer is flexible in allowing either single-ended or differential input drive. Its high common mode rejection provides excellent immunity to interference from noise sources. On-chip quantized feedback eliminates baseline wander.

Additional features include a Loss of Signal output and an output mute pin which, when tied together, mute the output when no signal is present. A buffered eye monitor output is provided, for viewing the equalized signal prior to the comparator. Differential AEC pins allow the user to set the internal adaptive loop time constant with one external capacitor.

**Table 1. Key Specifications**

	VALUE	UNIT
Low jitter: 180ps <sub>pp</sub> @ 270 Mbps through 200 meters of Belden 8281 coaxial cable		
High data rates: < 50 Mbps to > 650 Mbps		
Excellent input return loss: 19 dB @ 270 MHz		
Low supply current: 68 mA		
Equalizes up to 300+ meters of Belden 8281 or 120 meters of Cat 5 UTP cable		



Please be aware that an important notice concerning availability, standard warranty, and use in critical applications of Texas Instruments semiconductor products and disclaimers thereto appears at the end of this data sheet.

All trademarks are the property of their respective owners.

Typical Application

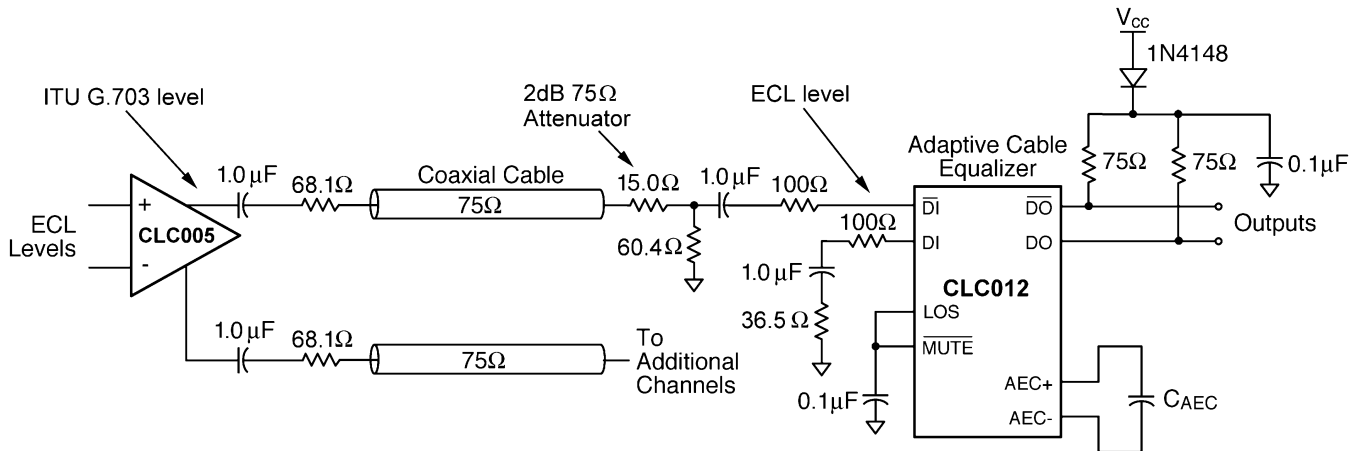

Before Equalization: 622Mbps  
200m of Belden 8281 Coaxial Cable

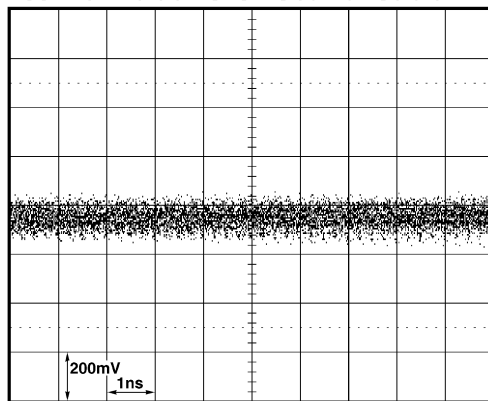

After Equalization: 622Mbps  
200m of Belden 8281 Coaxial Cable

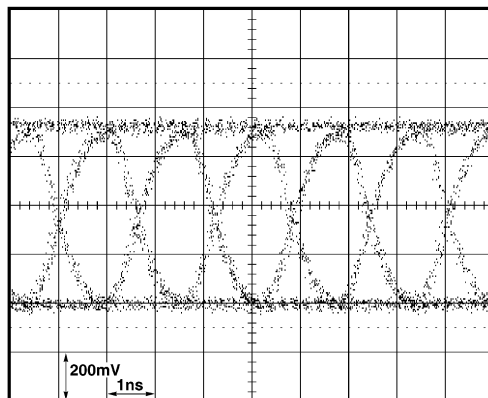

## Connection Diagram

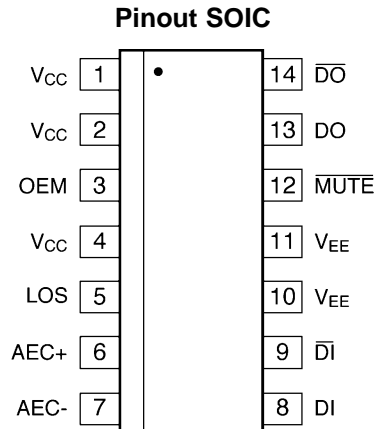

**Figure 1.**  
**14-Pin SOIC**



These devices have limited built-in ESD protection. The leads should be shorted together or the device placed in conductive foam during storage or handling to prevent electrostatic damage to the MOS gates.

### Absolute Maximum Ratings <sup>(1)</sup>

Supply Voltage (V <sub>CC</sub> -V <sub>EE</sub> )	-0.3V, +6.5V
Maximum Junction Temperature	+150°C
Storage Temperature Range	-65°C to +150°C
Lead Temperature (Soldering 4 sec.)	+260°C
ESD Rating <sup>(2)</sup>	≥500V
θ <sub>JA</sub> 14-Pin SOIC (AJE)	95°C/W
MTTF (based on limited life test data)	4.8 x 10 <sup>7</sup> hours

- (1) "Absolute Maximum Ratings" are those values beyond which the safety of the device cannot be guaranteed. They are not meant to imply that the devices should be operated at these limits. The table of "Electrical Characteristics" specifies conditions of device operation.
- (2) Human body model, 1.5 kΩ in series with 100 pF; based on limited test data.

### Recommended Operating Conditions

Supply Voltage (V <sub>CC</sub> -V <sub>EE</sub> )	4.5V to 5.5V
Operating Temperature Range	-40°C to +85°C
Series Input Resistance (In Series w/DI & $\overline{DI}$ )	100Ω
Input Coupling Capacitance	1.0 μF
AEC Capacitor (Connected between AEC+ & AEC-)	50 pF to 1 μF
Cable Input Voltage Swing <sup>(1)</sup>	720 to 880 mV <sub>pp</sub>
DO/ $\overline{DO}$ Minimum Voltage <sup>(2)</sup>	V <sub>CC</sub> -1.6V

- (1) These specifications assume an 800 mV<sub>pp</sub> signal at the cable input. Levels above and below 800 mV are allowable, but performance may vary. The cable will attenuate the signal prior to entering the equalizer.
- (2) To maintain specified performance, do not reduce DO/ $\overline{DO}$  below this level.

## Electrical Characteristics

( $V_{CC} = +5V$ ,  $V_{EE} = 0V$ , signal source swing =  $0.8 V_{pp}$ <sup>(1)</sup>,  $C_{AEC} = 100 pF$ )

Parameter	Conditions	Typ +25°C	Min/Max +25°C <sup>(2)</sup>	Min/Max -40°C to +85°C <sup>(2)</sup>	Units
<b>DYNAMIC PERFORMANCE</b>					
<b>Residual Jitter</b>					
10 meters Belden 8281	311 Mbps PRN <sup>(3)</sup>	150	250	400	ps <sub>pp</sub>
300 meters Belden 8281	311 Mbps PRN <sup>(4) (3)</sup>	350	500	750	ps <sub>pp</sub>
<b>Equalization Time Constant</b>					
100 meters Belden 8281	$C_{AEC} = 100 pF$ <sup>(5)</sup>	1.5	–	–	μs
200 meters Belden 8281	$C_{AEC} = 100 pF$ <sup>(5)</sup>	2.0	–	–	μs
300 meters Belden 8281	$C_{AEC} = 100 pF$ <sup>(5)</sup>	3.2	–	–	μs
output rise and fall time (20%–80%)	$R_{collector} = 75\Omega$	750	–	–	ps
output duty cycle distortion		30	–	–	ps
minimum average transition density		1/50	–	–	trans/ns
maximum average data rate	150m Belden 8281 <sup>(6)</sup>	650	–	–	Mbps
<b>V<sub>CC</sub> Jitter Sensitivity</b>					
27 MHz		0.85	–	–	ns/V
270 MHz		1.90	–	–	ns/V
<b>V<sub>EE</sub> Jitter Sensitivity</b>					
27 MHz		0.55	–	–	ns/V
270 MHz		1.45	–	–	ns/V
<b>STATIC PERFORMANCE</b>					
<b>Supply Current (Includes Output Current)</b>					
$V_{AEC} = 0V$	<sup>(4)</sup>	68	48/75	40/80	mA
$V_{AEC} = 0.4V$	<sup>(4)</sup>	53	43/64	37/70	mA
<b>Input and Output Parameters</b>					
DO/ $\overline{DO}$ output current		10	8.7/11.3	8.0/12	mA
DO/ $\overline{DO}$ output voltage swing	$R_{collector} = 75\Omega$ <sup>(4)</sup>	750	650/850	600/900	mV
DI/ $\overline{DI}$ common mode voltage		3.4	–	–	V
AEC differential voltage	Belden 8281	1.5	–	–	mV/meter
AEC+/AEC- common mode		3.6	–	–	V
output eye monitor (OEM) bias potential		3.2	–	–	V
Loss of Signal (LOS) current output-HIGH	LOS $V_{OH} = 4.5V$	-400	–	–	μA
Loss of Signal (LOS) current output-LOW	LOS $V_{OL} = 0.5V$	600	–	–	μA
$\overline{MUTE}$ voltage input-HIGH	<sup>(4)</sup>	1.8	2.0	2.0	V
$\overline{MUTE}$ voltage input-LOW	<sup>(4)</sup>	1.2	0.8	0.8	V
$\overline{MUTE}$ current input-HIGH	$V_{IH} = 5V$ <sup>(4)</sup>	5.0	±100	±500	nA
$\overline{MUTE}$ current input-LOW	$V_{IL} = 0V$ <sup>(4)</sup>	0.2	±100	±500	nA
<b>TIMING PERFORMANCE</b>					
<b>LOS Response Time</b>					
carrier applied	<sup>(7)</sup>	150	1000	1000	ns

- (1) These specifications assume an 800 mV<sub>pp</sub> signal at the cable input. Levels above and below 800 mV are allowable, but performance may vary. The cable will attenuate the signal prior to entering the equalizer.
- (2) Min/max ratings are based on product characterization and simulation. Individual parameters are tested as noted. Outgoing quality levels are determined from tested parameters.
- (3) Peak-to-peak jitter is defined as 6 times the rms jitter.
- (4) J-level: spec. is 100% tested at +25°C.
- (5) For more information, see "CLC012 Operation" and "Design Guidelines".
- (6) 50% eye opening.
- (7) Time from application of a valid signal to when the LOS output asserts high.

**Electrical Characteristics (continued)**
 $(V_{CC} = +5V, V_{EE} = 0V, \text{signal source swing} = 0.8 V_{pp}^{(1)}, C_{AEC} = 100 \text{ pF})$ 

Parameter	Conditions	Typ +25°C	Min/Max +25°C <sup>(2)</sup>	Min/Max –40°C to +85°C <sup>(2)</sup>	Units
carrier removed	(8)	150	1000	1000	ns
$\overline{\text{MUTE}}$ response time	(9)	2.0	–	–	ns
<b>MISCELLANEOUS PERFORMANCE</b>					
input resistance	single-ended	7.3	–	–	kΩ
input capacitance	single-ended <sup>(10)</sup>	1.0	–	–	pF
input return loss @ 270 MHz	$Z_o = 75\Omega$ <sup>(11)</sup>	19	–	–	dB
maximum cable attenuation	200 MHz <sup>(12)</sup>	40	–	–	dB

(8) Time from the removal of a valid signal to when the LOS output asserts low.

(9) Time from assertion of  $\overline{\text{MUTE}}$  to when the output responds.

(10) Device only. Does not include typical pc board parasitics.

(11) Includes typical pc board parasitics.

(12) This sets the maximum cable length for the equalizer.

### Typical Performance Characteristics

**Before Equalization: 155Mbps  
50m of Belden 8281 Coaxial Cable**

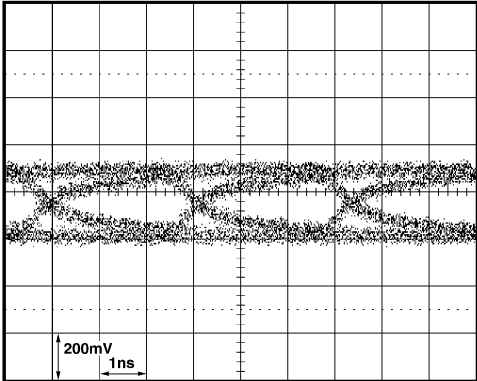

**After Equalization: 155Mbps  
50m of Belden 8281 Coaxial Cable**

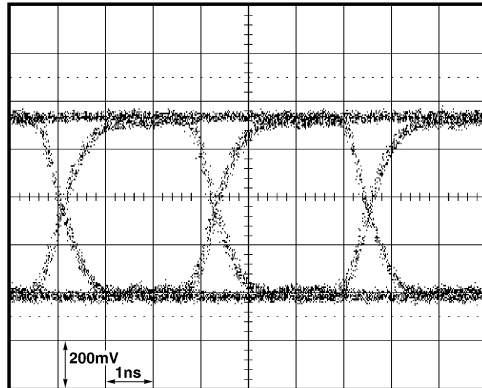

**Before Equalization: 155Mbps  
100m of Belden 8281 Coaxial Cable**

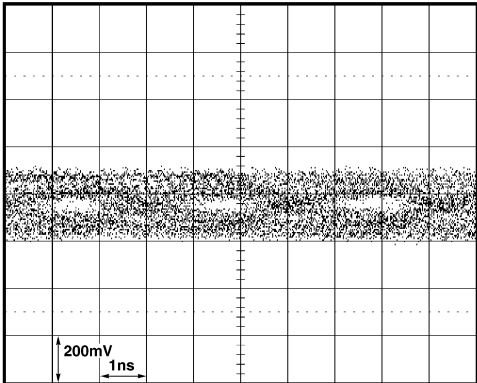

**After Equalization: 155Mbps  
100m of Belden 8281 Coaxial Cable**

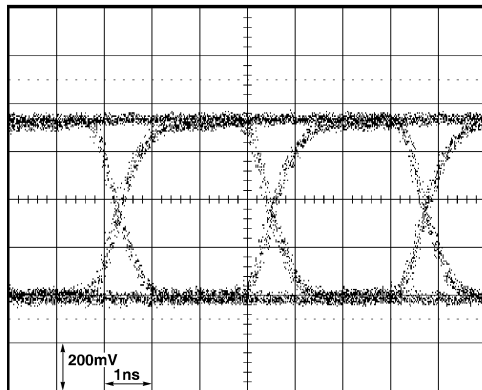

**Before Equalization: 155Mbps  
200m of Belden 8281 Coaxial Cable**

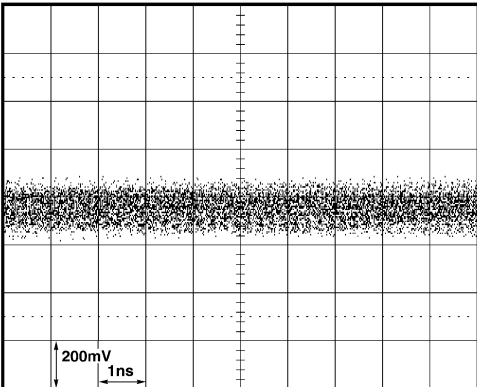

**After Equalization: 155Mbps  
200m of Belden 8281 Coaxial Cable**

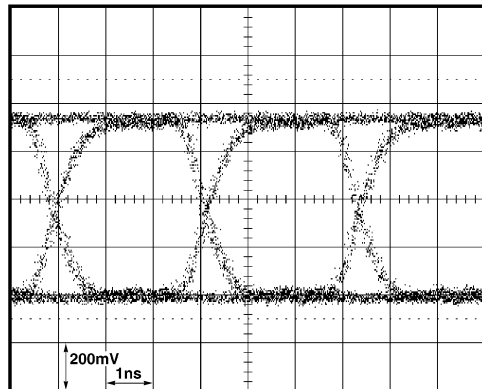

**Typical Performance Characteristics (continued)**

**Before Equalization: 155Mbps  
300m of Belden 8281 Coaxial Cable**

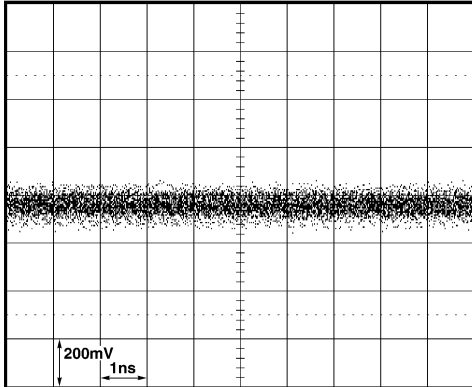

**After Equalization: 155Mbps  
300m of Belden 8281 Coaxial Cable**

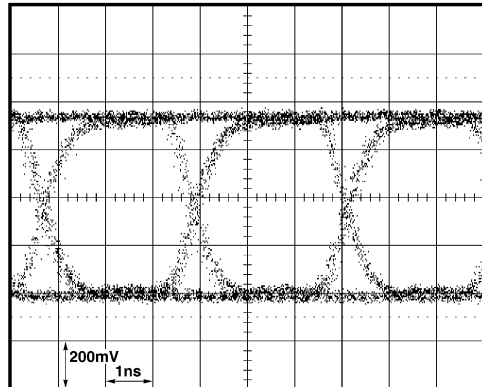

**Before Equalization: 622Mbps  
50m of Belden 8281 Coaxial Cable**

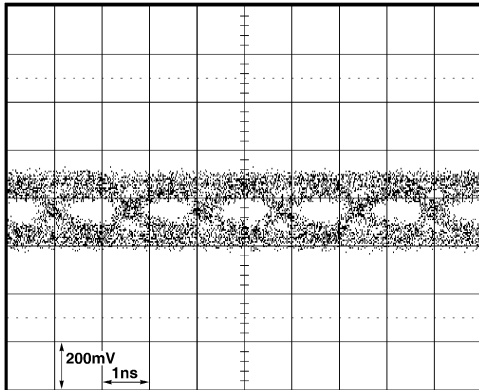

**After Equalization: 622Mbps  
50m of Belden 8281 Coaxial Cable**

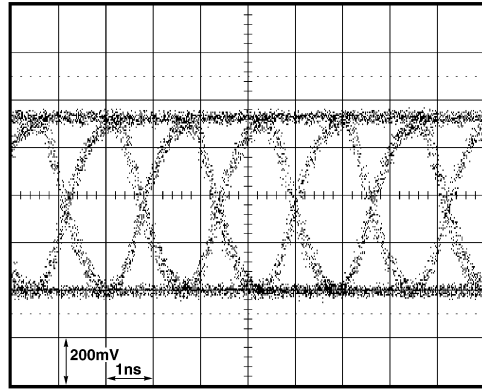

**Before Equalization: 622Mbps  
100m of Belden 8281 Coaxial Cable**

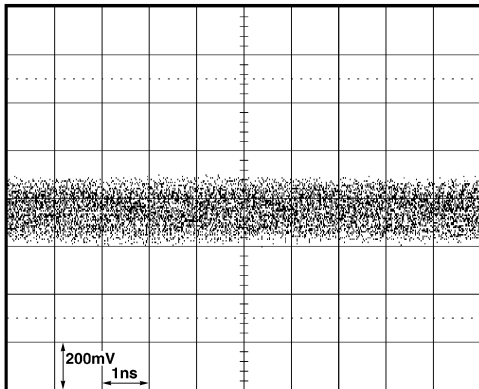

**After Equalization: 622Mbps  
100m of Belden 8281 Coaxial Cable**

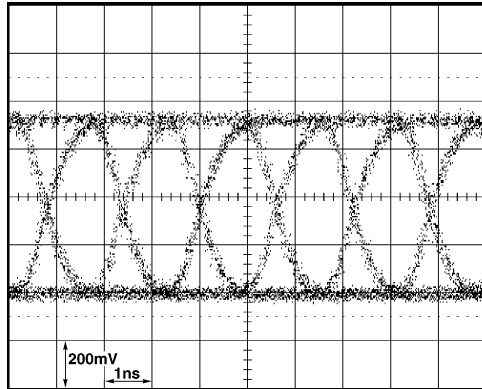

### Typical Performance Characteristics (continued)

**Before Equalization: 622Mbps  
200m of Belden 8281 Coaxial Cable**

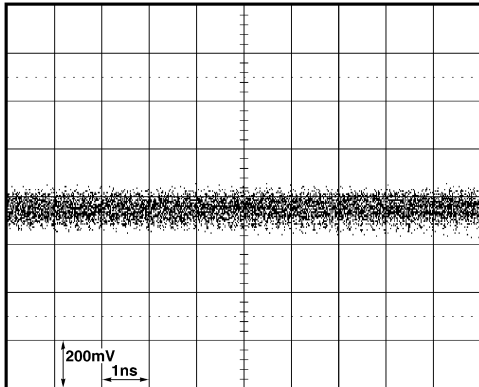

**After Equalization: 622Mbps  
200m of Belden 8281 Coaxial Cable**

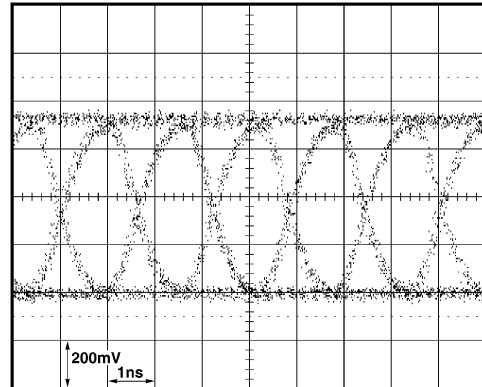

**Maximum Data Rate\* vs.  
Cable Length (Typical)**

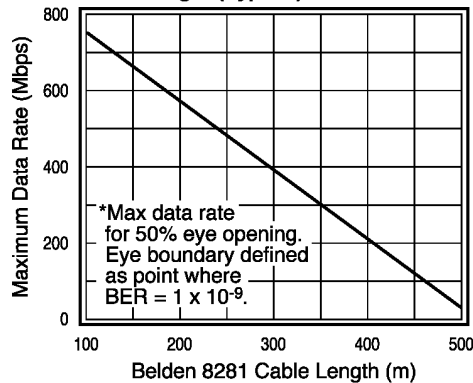

**Jitter vs. Cable Length**

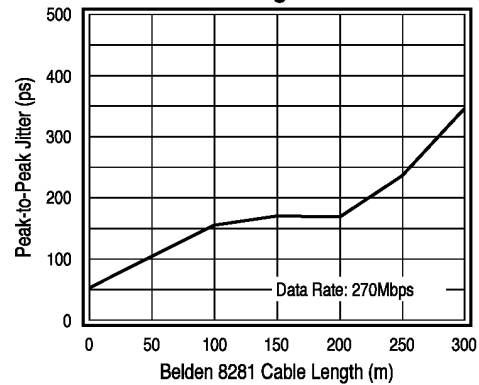

**Return Loss**

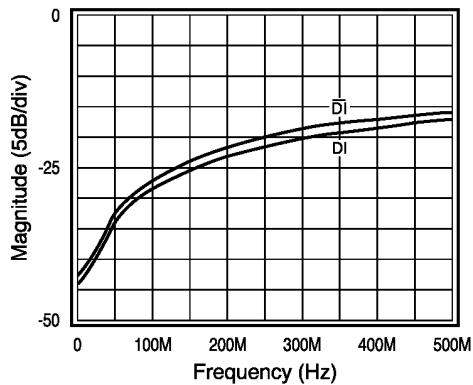

**CLC012 LOS Response**

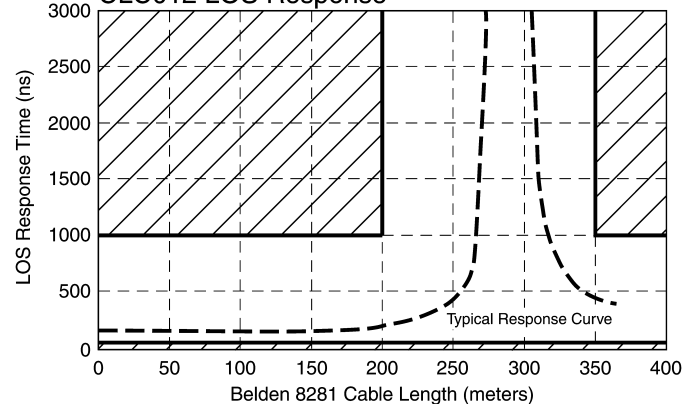

**Table 2. Pin Definitions**

Name	Pin #	Description
DI, $\overline{DI}$	8, 9	Differential data inputs.
DO, $\overline{DO}$	13, 14	Differential collector data outputs (ECL compatible).
AEC+, AEC-	6, 7	AEC loop filter pins. A capacitor connected between these pins governs the loop response for the adaptive equalization loop.
OEM	3	Eye monitor output. The output of the equalization filter.
LOS	5	Loss of Signal. (Low when no signal is present).



Table 2. Pin Definitions (continued)

Name	Pin #	Description
MUTE	12	Output MUTE. (Active low.)
		Loss of Signal (LOS) may be tied to this pin to inhibit the output when no signal is present.
V <sub>CC</sub>	1, 2, 4	Positive supply pins (ground or +5V).
V <sub>EE</sub>	10, 11	Negative supply pins (-5.2V or ground).

**Operation**

The CLC012 Adaptive Cable Equalizer provides a complete solution for equalizing high-bit-rate digital data transmitted over long transmission lines. The following sections furnish design and application information to assist in completing a successful design:

- Block diagram explanation of the CLC012
- Recommended standard input and output interface connections
- Common applications for the CLC012
- Measurement, PC layout, and cable emulation boxes

For applications assistance in the U.S., call 800-272-9959 to contact a technical staff member.

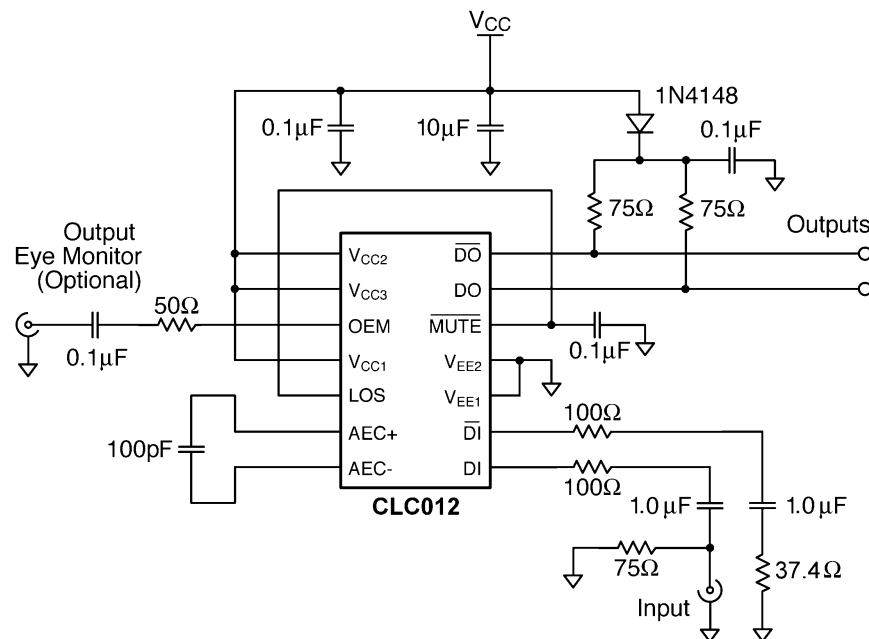

Figure 2. CLC012 Equalizer Application Circuit

**BLOCK DESCRIPTION**

The CLC012 is an adaptive equalizer that reconstructs serial digital data received from transmission lines such as coaxial cable or twisted pair. Its transfer function approximates the reciprocal of the cable loss characteristic. The block diagram in Figure 3 depicts the main signal conditioning blocks for equalizing digital data at the receiving end of a cable. The CLC012 receives baseband differential or single-ended digital signals at its inputs DI and  $\overline{DI}$ .

The **Equalizer** block is a two-stage adaptive filter. This filter is capable of equalizing cable lengths from zero meters to lengths that require 40 dB of boost at 200 MHz.

The **Quantized Feedback Comparator** block receives the differential signals from the equalizer filter block. This block includes two comparators. The first comparator incorporates a self-biasing DC restore circuit. This is followed by a second high-speed comparator with output mute capability. The second comparator receives and slices the DC-restored data. Its outputs  $\overline{DO}$  and  $\overline{D\overline{O}}$  are taken from the collectors of the output transistors. MUTE latches  $\overline{DO}$  and  $\overline{D\overline{O}}$  when a TTL logic low level is applied.

The **Adaptive Servo Control** block produces the signal for controlling the filter block, and outputs a voltage proportional to cable length. It receives differential signals from the output of the filter block and from the quantized-feedback comparator (QFBC) to develop the control signal. The servo loop response is controlled by an external capacitor placed across the AEC+ and AEC- pins. Its output voltage, as measured differentially across AEC+ and AEC-, is roughly proportional to the length of the transmission line. For Belden 8281 coaxial cable this differential voltage is about 1.5 mV/meter. Once this voltage exceeds 500 mV, no additional equalization is provided.

The **Loss of Signal (LOS)** block monitors the signal power out of the equalizing filter and compares it to an internal reference to determine if a valid signal is present. A CMOS high output indicates that data is present. The output of LOS can be connected to the MUTE input to automatically latch the outputs ( $\overline{DO}$  and  $\overline{D\overline{O}}$ ), preventing random transitions when no data is present.

The **Output Eye Monitor (OEM)** provides a single-ended buffered output for observing the equalized eye pattern. The OEM output is a low impedance high-speed voltage driver capable of driving an AC-coupled 100 $\Omega$  load.

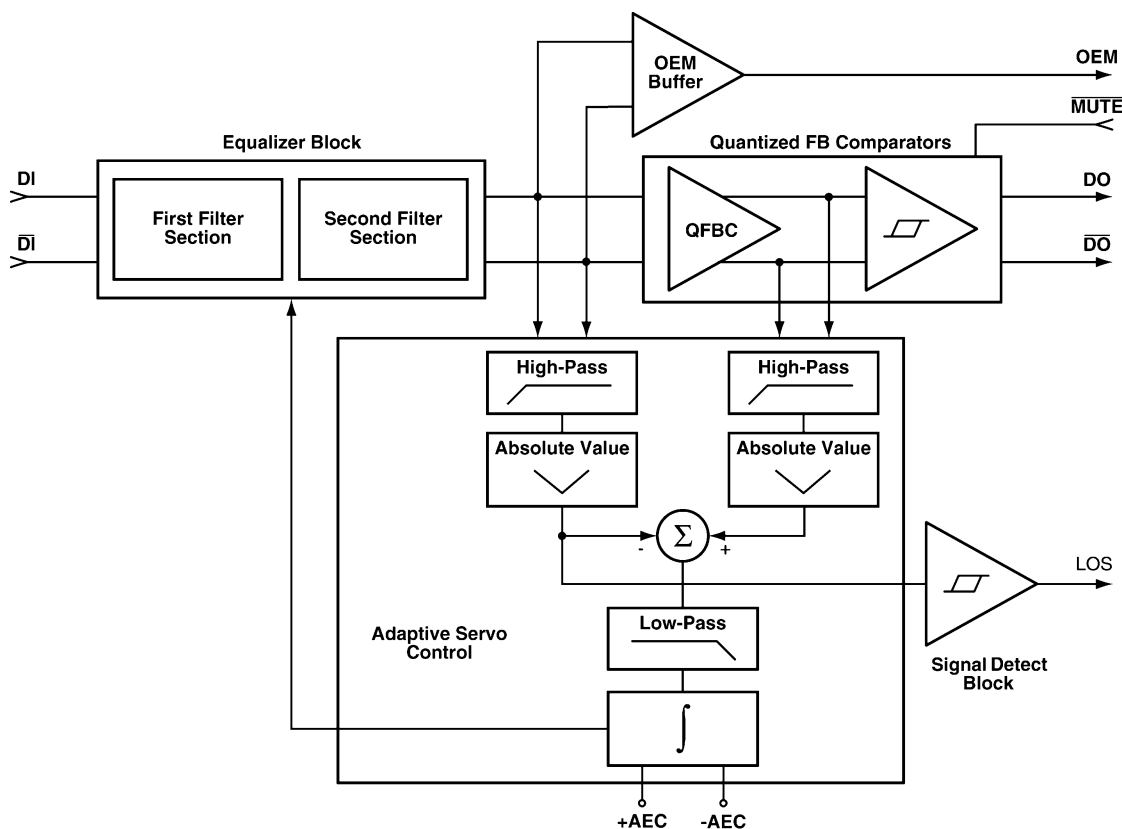

Figure 3. CLC012 Block Diagram

## DEVICE TESTING

Performance or compliancy testing of the CLC012 with **Cable Clones** is not allowed. Use of these devices is contrary to the product's specifications and test procedures. Testing for product specifications or performance using cable clones is invalid since cable clones have a different frequency response than the actual cable. Testing with full length cable samples is recommended.

## Input Interfacing

The CLC012 accepts either differential or single-ended input voltage specified in **Static Performance**. The following sections show several suggestions for interfaces for the inputs and outputs of the CLC012.

### SINGLE-ENDED INPUT INTERFACE: 75Ω Coaxial Cable

The input is connected single-ended to either DI or  $\overline{\text{DI}}$  as shown in Figure 4. Balancing unused inputs helps to lessen the effects of noise. Use the equivalent termination of 37.4Ω to balance the input impedance seen by each pin. It also helps to terminate grounds at a common point. Resistors  $R_x$  and  $R_y$  are recommended for optimum performance. The equalizer inputs are self-biasing. Signals should be AC coupled to the inputs as shown in Figure 4.

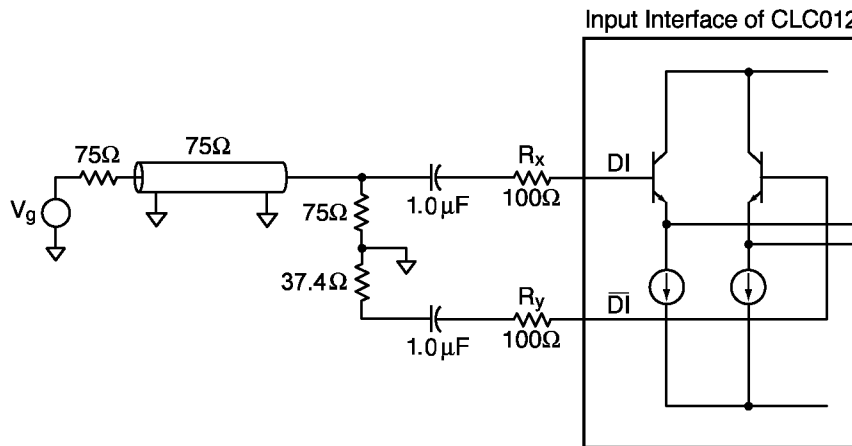

Figure 4. Single-Ended 75Ω Cable Input Interface

### DIFFERENTIAL INPUT INTERFACE: Twisted Pair

A recommended differential input interface is shown in Figure 5. Proper voltage levels must be furnished to the input pins and the proper cable terminating impedance must be provided. For Category 5 UTP this is approximately 100Ω. Figure 5 shows a generalized network which may be used to receive data over a twisted pair. Resistors  $R_1$  and  $R_2$  provide the proper terminating impedance and signal level adjustment. The blocking capacitors provide AC coupling of the attenuated signal levels. The plots in the **Typical Performance Characteristics** section demonstrate various equalized data rates using Category 5 UTP at 100 meter lengths. A full schematic of a recommended driver and receiver circuit for 100Ω Category 5 UTP is provided in the **Typical Applications** section with further explanation.

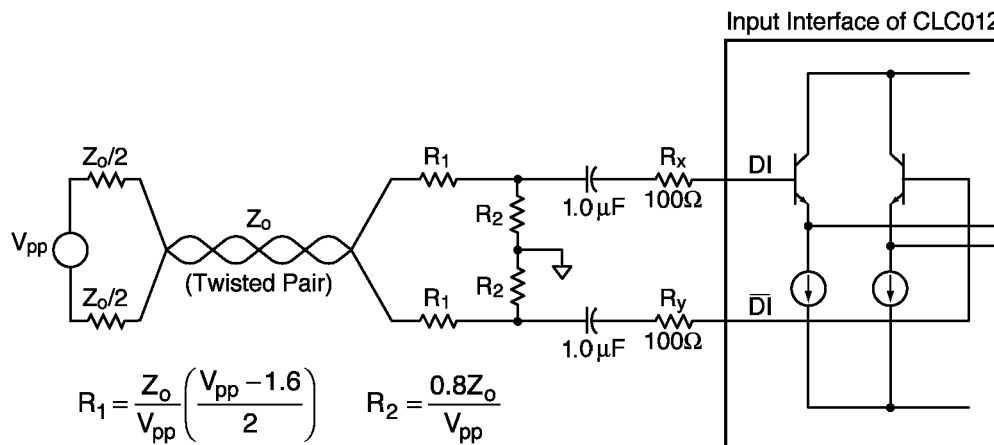

Figure 5. Twisted Pair Input Interface

## Output Interfacing

The outputs DO and  $\overline{\text{DO}}$  produce ECL logic levels when the recommended output termination networks are used. The DO and  $\overline{\text{DO}}$  pins are **not complementary emitter coupled logic** outputs. Instead, the outputs are taken off of the collectors of the transistors. Therefore, care must be taken to meet the interface threshold levels required by ECL families. Recommended interfaces for standard ECL families are shown in the following circuits.

### DIFFERENTIAL LOAD-TERMINATED OUTPUT INTERFACE

Figure 6 shows a recommended circuit for implementing a differential output that is terminated at the load. A diode or  $75\Omega$  resistor provides a voltage drop from the positive supply ( $+5\text{V}$  for PECL or Ground for ECL operation) to establish proper ECL levels. The resistors terminate the cable to the characteristic impedance. The output voltage swing is determined by the CLC012 output current (10 mA) times the termination resistor. For the circuit in Figure 6, the nominal output voltage swing is 750 mV.

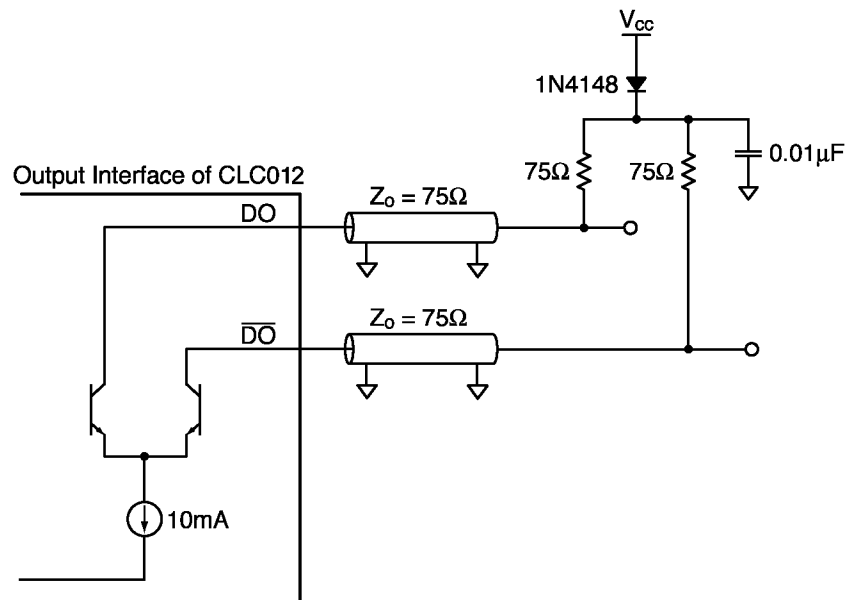

Figure 6. Differential Load Terminated Output Interface

### DIFFERENTIAL SOURCE-TERMINATED OUTPUT INTERFACE

Figure 7 is similar to Figure 6 except that the termination is provided at the source. This configuration may also be used for single-ended applications. However, the unused output must still be terminated as shown.

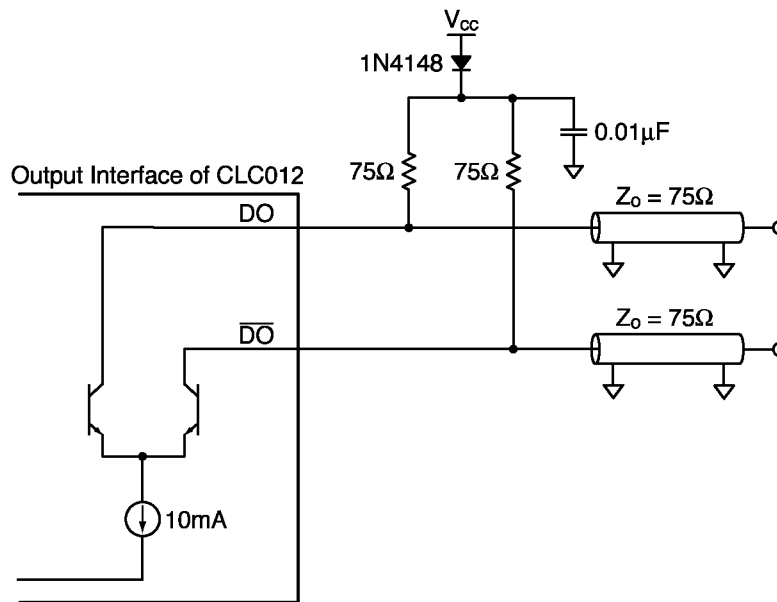

Figure 7. Differential Source Terminated Output Interface

### TERMINATING PHYSICALLY SEPARATED OUTPUTS

When the two outputs must be routed to physically separate locations, the circuit in Figure 7 may be applied. Alternatively, if load termination is desired, the circuit in Figure 8 may be used. The resistive divider network provides 75Ω termination and establishes proper ECL levels. This circuit consumes slightly more power than the previous circuits.

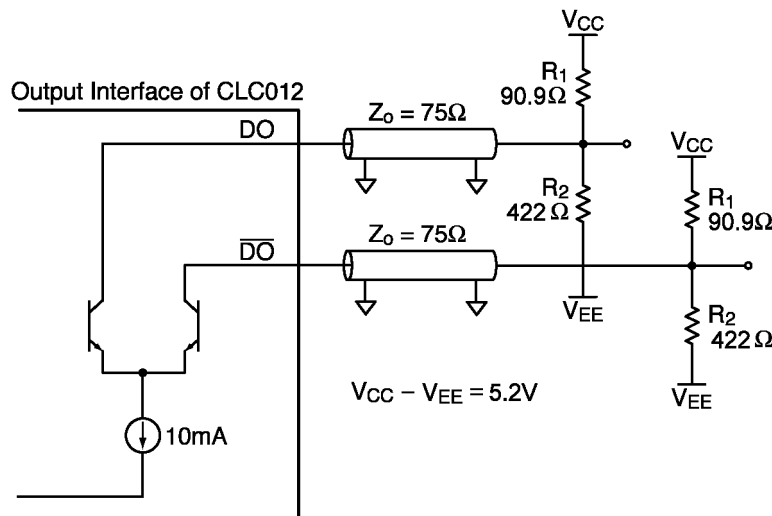

Figure 8. Alternative Load Terminated Output Interface

### Design Guidelines

#### SELECTING THE AUTOMATIC EQUALIZER CAPACITOR

The AEC capacitor sets the loop time constant  $\tau$  for the equalizer's adaptive loop response time. The following formula is used to set the loop time constant:

$$\tau = R \cdot C_{AEC} \cdot 10^{-6} \quad (1)$$

R is a conversion factor that is set by internal equalizer parameters and cable length. For Belden 8281 coaxial cable, the R values are ( $\tau = \mu\text{s}$ ,  $C_{AEC}$  in pF):

Cable Length	R Value (Ohms)
100 meters	15000
200 meters	20000
300 meters	32000

For example, a  $C_{AEC}$  value of 100 pF results in an adaptive loop time constant of 2  $\mu\text{s}$  at 200 meters of cable.

### CONNECTION AND OPERATION OF LOS AND $\overline{\text{MUTE}}$

**Loss of Signal (LOS)** is a CMOS output that indicates the presence of equalized data from the filter. This LOS output can be connected to  $\overline{\text{MUTE}}$  to suspend changes in the data outputs DO and  $\overline{\text{DO}}$ , if no valid signal exists. This simple configuration prevents random output transitions due to noise. For sparse transition patterns it is recommended that a capacitor be connected to LOS as shown in [Figure 2](#).

Add a capacitor to pin 5 to slow the response time of Loss of Signal when LOS is connected to  $\overline{\text{MUTE}}$ . The capacitor reduces sensitivity to pathological patterns. Pathological patterns are defined as sparse data sequences with few transitions.

### OUTPUT EYE MONITOR OEM CONNECTIONS

The OEM is a high-speed, buffered output for monitoring the equalized eye pattern prior to the output comparator. Its output is designed to drive an AC-coupled 50 $\Omega$  coaxial cable with a series 50 $\Omega$  backmatch resistor. The cable should be terminated with 50 $\Omega$  at the oscilloscope. [Figure 2](#) shows a schematic with a typical connection.

### MINIMUM DATA TRANSITIONS

The CLC012 specifies a minimum transition rate. For the CLC012 this sets the minimum data rate for transmitting data through any cable medium. The CLC012 minimum average transition density is found in the Electrical Characteristics section of the datasheet.

### POWER SUPPLY OPERATION AND THERMAL CONSIDERATIONS

The CLC012 operates from either +5V or -5.2V single supplies. Refer to [Figure 2](#) when operating the part from +5V. When operating with a -5.2V supply, the  $V_{EE}$  pins should be bypassed to ground. The evaluation board and associated literature provide for operation from either supply.

Maximum power dissipation occurs at minimum cable length. Under that condition,  $I_{CC} = 58 \text{ mA}$ .

Total power dissipated:

$$P_T = (58 \text{ mA})(5V) = 290 \text{ mW}$$

Power in the load:

$$P_L = (0.7V)(11 \text{ mA}) + (37.5)(11 \text{ mA})^2 = 12 \text{ mW}$$

Maximum power dissipated on the die:

$$P_{D\text{MAX}} = P_T - P_L = 278 \text{ mW}$$

Junction Temperature =

$$(\theta_{JA})(278 \text{ mW}) + T_A = T_A + 26^\circ\text{C}$$

### Layout and Measurement

The printed circuit board layout for the CLC012 requires proper high-speed layout to achieve the performance specifications found in the datasheet. The following list contains a few rules to follow:

1. Use a ground plane.
2. Decouple power pins with 0.1  $\mu\text{F}$  capacitors placed  $\leq 0.1''$  (3mm) from the power pins.

3. Design transmission strip lines from the CLC012's input and output pins to the board connectors.
4. Route outputs away from inputs.
5. Keep ground plane  $\geq 0.025''$  (0.06mm) away from the input and output pads.

Figure 9 shows a block level measurement diagram, while Figure 16 on depicts a detailed schematic. A pseudo-random pattern generator with low output jitter was used to provide a NRZI pattern to create the eye diagrams shown in the **Typical Performance Characteristics** section.

Since most pattern generators have a 50Ω output impedance, a translation can be accomplished using a CLC005 Cable Driver as an impedance transformer. A wide bandwidth oscilloscope is needed to observe the high data rate eye pattern. When monitoring a single output that is terminated at both the equalizer output and the oscilloscope, the effective output load is 37.4Ω. Consequently, the signal swing is half that observed for a single-ended 75Ω termination.

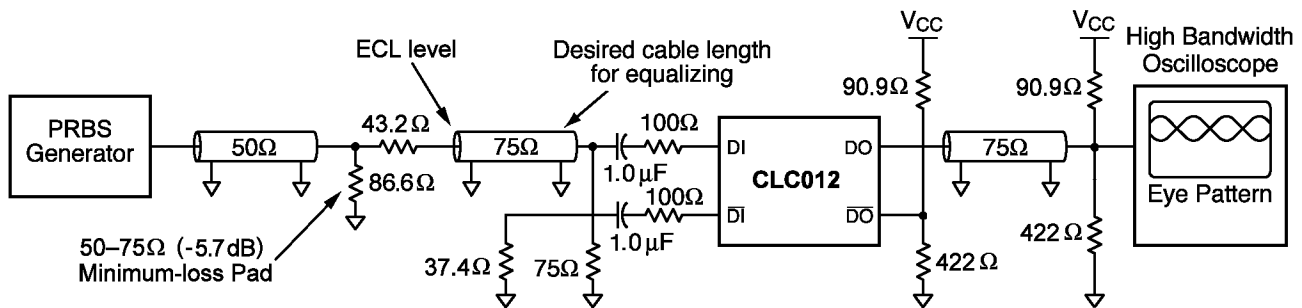

Figure 9. Typical Measurement Block

Troubleshooting with scope probes can affect the equalization. For high data rates, use a **low capacitance probe** with less than 2 pF probe capacitance. Evaluation boards and literature are available for quick prototyping and evaluation of the CLC012 Adaptive Cable Equalizer. The CLC012 contains CMOS devices and operators should **use grounding straps when handling** the parts.

Figure 10 shows the CLC012's internal power supply routing. Bypass  $V_{CC}$  (pin 4) by:

- Monolithic capacitor of about 0.1  $\mu\text{F}$  placed less than 0.1" (3mm) from the pin
- Tantalum capacitor of about 6.8  $\mu\text{F}$  for large current signal swings placed as close as convenient to the CLC012

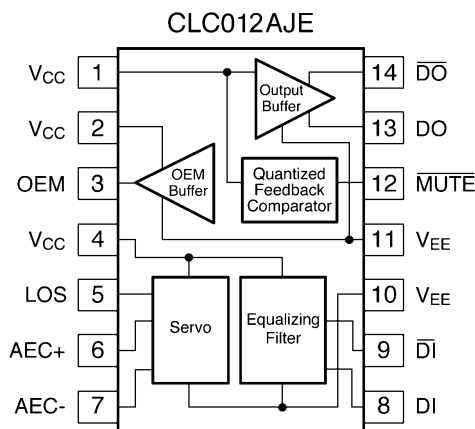

Figure 10. Power Package Routing Fixture

To minimize ringing at the CLC012's inputs, place a 100Ω resistor in series with the input. This resistor reduces inductance effects.

Several layout techniques can improve high speed performance:

- Keep input, output and AEC traces well separated
- Use balanced input termination's
- Avoid routing traces close to the CLC012's input trace
- Maintain common return points for components
- Use guard traces

The input lines of the CLC012 use a 100Ω series resistors at the input pins. This decreases the inductive effects internal to the part to reduce ringing on fast rise and fall times. Refer to the evaluation board layout for further suggestions on layout for the CLC012 Adaptive Equalizer.

## EQUALIZATION CURVE

The CLC012 Adaptive Cable Equalizer has a maximum equalization response as shown in [Figure 11](#). This response may be obtained by forcing >0.5V differentially at the AEC pins.

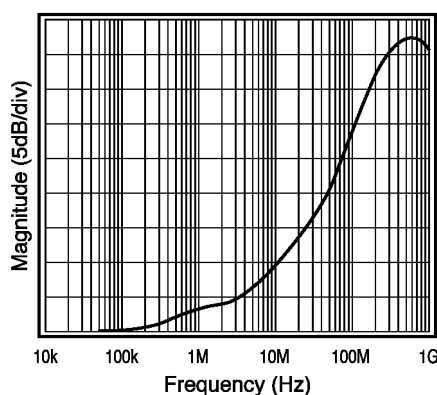

**Figure 11. Maximum Equalization Response**

## CABLE EMULATION BOXES

Some cable emulation boxes will not mimic cables correctly. When evaluating the CLC012, it is strongly recommended that actual cable be used to determine the various performance parameters.

## Typical Applications

### COAXIAL CABLE RECEIVER (Page 1)

The CLC012 equalizer application shown on page 1 will equalize a variety of coaxial cables up to lengths that attenuate the signal by 40 dB at 200 MHz. The application shows the proper connection for a single cable driven with a CLC005 driver. Loss of Signal (LOS) is connected to  $\overline{\text{MUTE}}$  to latch outputs DO and  $\overline{\text{DO}}$  in the absence of an input signal to the equalizer.

Refer to the CLC012's evaluation board layout for additional suggestions.

National can supply most of the major components required to design a transmission line repeater. [Figure 12](#) shows a typical repeater design using the CLC005, CLC012, and the CLC016. The design functions supported by each chip are:

#### **CLC005:** Cable connection chip

Boosts drive for transmission to next repeater or final destinations

#### **CLC012:** Receive serialized digital data from incoming transmission lines

Equalizes the incoming data

#### **CLC016:** Retimes the equalized data (improving jitter)

The CLC016 is a multi-rate data retiming PLL. The circuit ([Figure 12](#)) will work at up to 4 different data rates with no additional components or manual tuning.



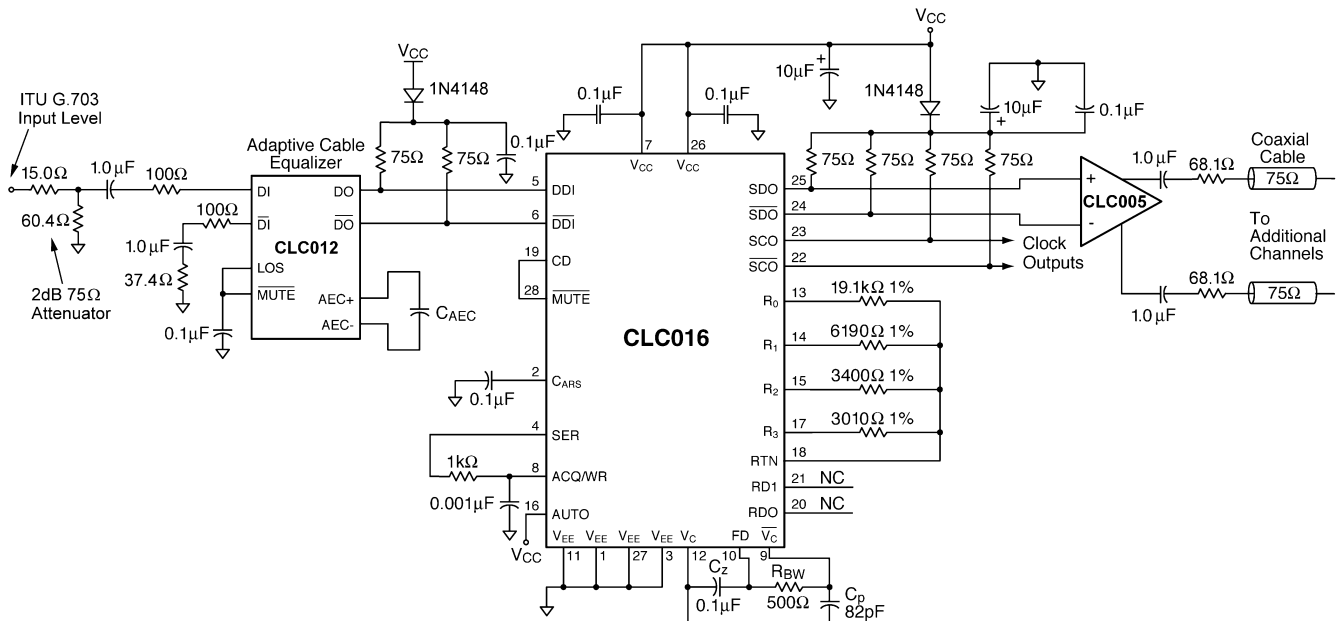

Figure 12. Typical Repeater Design

## DIGITAL VIDEO (SDV) ROUTERS

The CLC012 provides performance that complies with the ITU-T G.703 standard for serial digital data transmission over coaxial cable. One common application is in routers, which provide a switching matrix for connecting source equipment to destination equipment.

Figure 13 shows a typical configuration for a router, including equalizers, a crosspoint switch, data retimers, and cable drivers. The CLC012 is used in its standard configuration in this application, and automatically equalizes cable lengths from zero meters to greater than 300 meters at 360 MHz (see plots in **Typical Performance Characteristics** section). The equalized outputs are connected to the differential inputs of the crosspoint switch. The CLC016 Data Retimer receives the data from the crosspoint and performs the clock and data recovery functions, further reducing jitter. Finally, the retimed data is driven into the coaxial cable by a CLC005 ITU-T G.703 Cable Driver (with two amplitude-adjustable outputs).

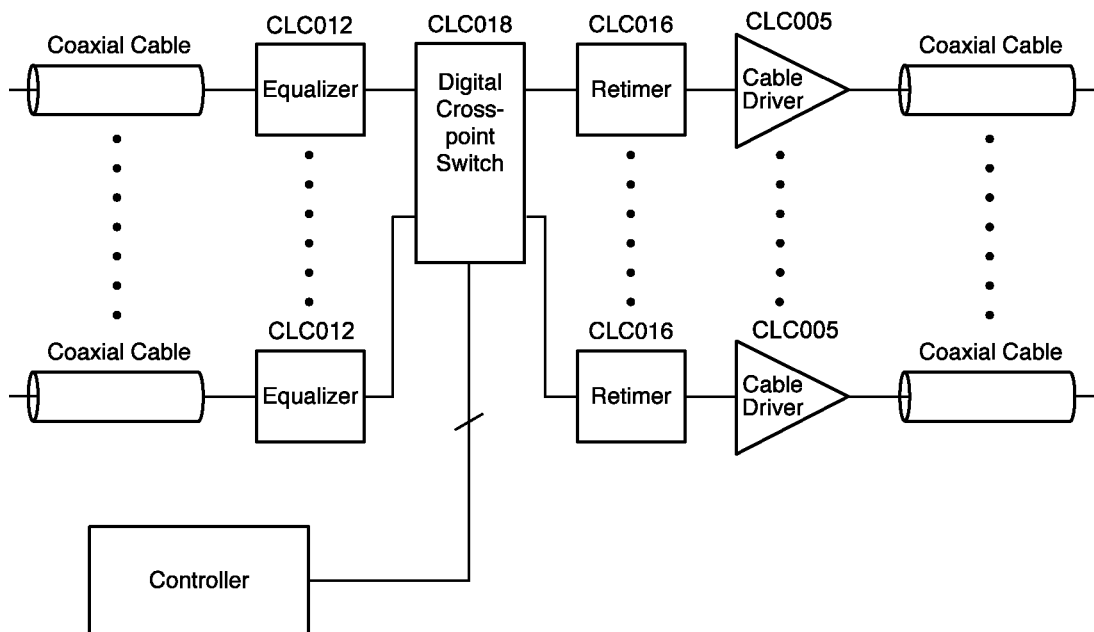

Figure 13. Data Routing Block Diagram

## TWISTED PAIR DRIVER

A low-cost medium for transmitting data is twisted pair. Category 5 UTP has an attenuation characteristic similar to Belden 8281 coaxial cable but scaled in length: 120 meters of Category 5 UTP is roughly equivalent to 300 meters of Belden 8281 cable. When properly implemented, the CLC012 will equalize data rates up to 625 Mbps over Category 5 UTP. The maximum data rate depends upon the cable length. A plot of Maximum Data Rate vs Cable Length is found in the **Typical Performance Characteristics** section for Belden 8281, and can be scaled as stated above to estimate maximum cable lengths and data rates for UTP.

Category 5 UTP has a characteristic impedance of approximately  $100\Omega$ . The CLC005 in Figure 14 is used to drive the twisted pair AC-coupled with a series  $0.1\ \mu\text{F}$  capacitor and a  $50\Omega$  resistor in each differential output. The CLC012 Adaptive Equalizer requires  $800\ \text{mV}_{\text{pp}}$  from the transmit side of the cable. A voltage divider is necessary to scale the voltage to the required level at the input of the CLC012. This resistor network also provides the correct impedance match for twisted pair.

For Category 5 UTP, the approximate AEC voltage per length is  $3.75\ \text{mV/m}$  (see **Block Description**). The CLC005 provides a trim adjust for fine tuning the output signal with the resistor R. Refer to the CLC005 datasheet for tuning directions.

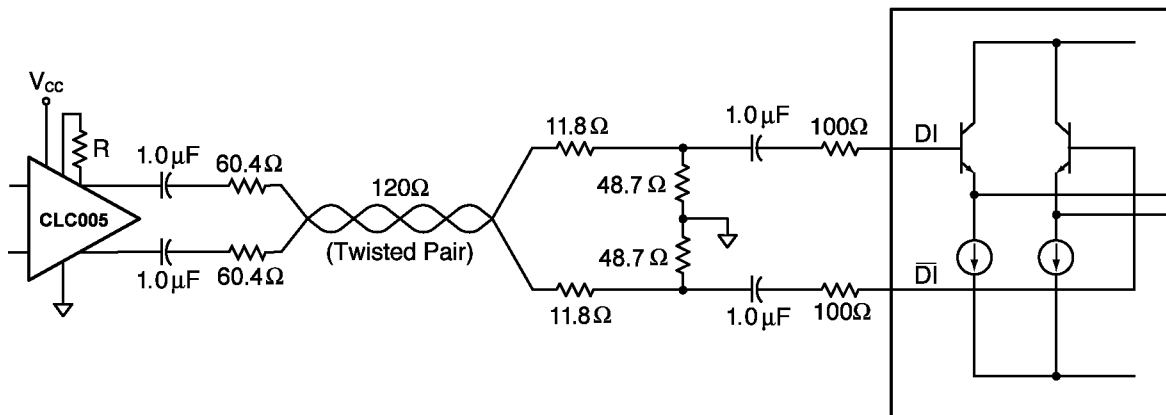

Figure 14. Twisted Pair Equalization

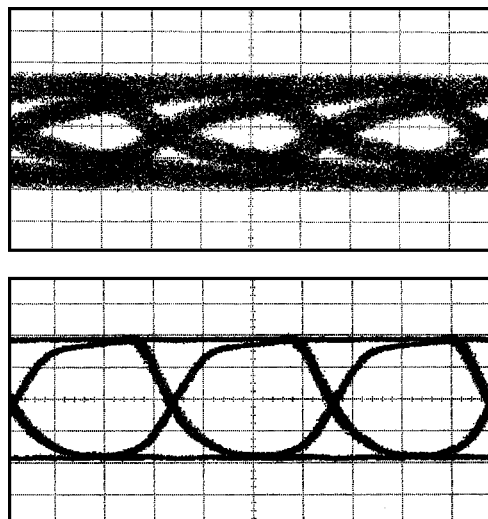
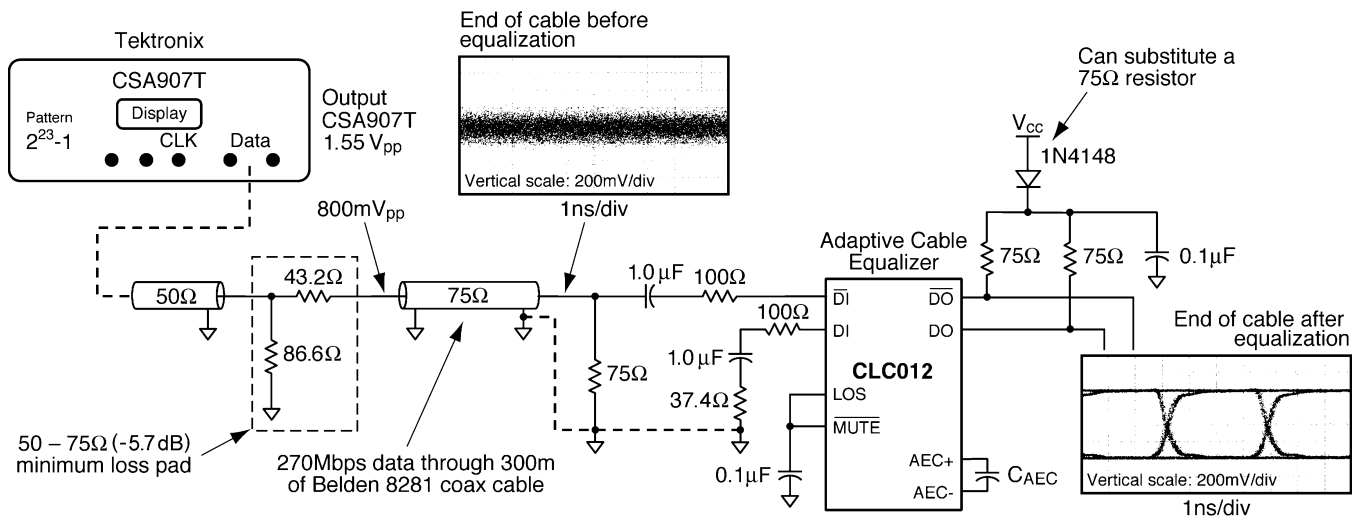

Figure 15. Before and After Equalization at 622 Mbps Through 50 Meters of Category 5 UTP



**Figure 16. Typical Measurement Setup**

## Evaluation Board

Evaluation boards are available for a nominal charge that demonstrate the basic operation of the SDI/SDV/SDH devices. The evaluation boards can be ordered through National's Distributors. Supplies are limited, please check for current availability.

The SD012EVK evaluation kit for the CLC012, Adaptive Cable Equalizer for ITU-T G.703 Data Recovery, provides an operating environment in which the cable equalizer can be evaluated by system / hardware designers. The evaluation board has all the needed circuitry and connectors for easy connection and checkout of the device circuit options as discussed in the CLC012 datasheet. A schematic, parts list and pictorial drawing are provided with the board.

From the WWW, the following information may be viewed / downloaded for most evaluation boards:  
[www.national.com/appinfo/interface](http://www.national.com/appinfo/interface)

- Device Datasheet and / or EVK User Manual
- View a picture of the EVK
- View the EVK Schematic
- View the top assembly drawing and BOM
- View the bottom assembly drawing and BOM

## PCB LAYOUT

The CLC012 requires proper high-speed layout techniques to obtain best results. A few recommended layout rules to follow for best results when using the CLC012 Adaptive Cable Equalizer are:

1. Use a ground plane.
2. Decouple power pins with 0.01  $\mu$ F capacitors placed  $\leq 0.1$ " (3mm) from the power pins.
3. Design transmission lines to the inputs and outputs.
4. Route outputs away from inputs.
5. Remove ground plane  $\geq 0.025$ " (0.06mm) from the input and output pads.

## IMPORTANT NOTICE

Texas Instruments Incorporated and its subsidiaries (TI) reserve the right to make corrections, enhancements, improvements and other changes to its semiconductor products and services per JESD46, latest issue, and to discontinue any product or service per JESD48, latest issue. Buyers should obtain the latest relevant information before placing orders and should verify that such information is current and complete. All semiconductor products (also referred to herein as "components") are sold subject to TI's terms and conditions of sale supplied at the time of order acknowledgment.

TI warrants performance of its components to the specifications applicable at the time of sale, in accordance with the warranty in TI's terms and conditions of sale of semiconductor products. Testing and other quality control techniques are used to the extent TI deems necessary to support this warranty. Except where mandated by applicable law, testing of all parameters of each component is not necessarily performed.

TI assumes no liability for applications assistance or the design of Buyers' products. Buyers are responsible for their products and applications using TI components. To minimize the risks associated with Buyers' products and applications, Buyers should provide adequate design and operating safeguards.

TI does not warrant or represent that any license, either express or implied, is granted under any patent right, copyright, mask work right, or other intellectual property right relating to any combination, machine, or process in which TI components or services are used. Information published by TI regarding third-party products or services does not constitute a license to use such products or services or a warranty or endorsement thereof. Use of such information may require a license from a third party under the patents or other intellectual property of the third party, or a license from TI under the patents or other intellectual property of TI.

Reproduction of significant portions of TI information in TI data books or data sheets is permissible only if reproduction is without alteration and is accompanied by all associated warranties, conditions, limitations, and notices. TI is not responsible or liable for such altered documentation. Information of third parties may be subject to additional restrictions.

Resale of TI components or services with statements different from or beyond the parameters stated by TI for that component or service voids all express and any implied warranties for the associated TI component or service and is an unfair and deceptive business practice. TI is not responsible or liable for any such statements.

Buyer acknowledges and agrees that it is solely responsible for compliance with all legal, regulatory and safety-related requirements concerning its products, and any use of TI components in its applications, notwithstanding any applications-related information or support that may be provided by TI. Buyer represents and agrees that it has all the necessary expertise to create and implement safeguards which anticipate dangerous consequences of failures, monitor failures and their consequences, lessen the likelihood of failures that might cause harm and take appropriate remedial actions. Buyer will fully indemnify TI and its representatives against any damages arising out of the use of any TI components in safety-critical applications.

In some cases, TI components may be promoted specifically to facilitate safety-related applications. With such components, TI's goal is to help enable customers to design and create their own end-product solutions that meet applicable functional safety standards and requirements. Nonetheless, such components are subject to these terms.

No TI components are authorized for use in FDA Class III (or similar life-critical medical equipment) unless authorized officers of the parties have executed a special agreement specifically governing such use.

Only those TI components which TI has specifically designated as military grade or "enhanced plastic" are designed and intended for use in military/aerospace applications or environments. Buyer acknowledges and agrees that any military or aerospace use of TI components which have **not** been so designated is solely at the Buyer's risk, and that Buyer is solely responsible for compliance with all legal and regulatory requirements in connection with such use.

TI has specifically designated certain components which meet ISO/TS16949 requirements, mainly for automotive use. Components which have not been so designated are neither designed nor intended for automotive use; and TI will not be responsible for any failure of such components to meet such requirements.

### Products

Audio	<a href="http://www.ti.com/audio">www.ti.com/audio</a>
Amplifiers	<a href="http://amplifier.ti.com">amplifier.ti.com</a>
Data Converters	<a href="http://dataconverter.ti.com">dataconverter.ti.com</a>
DLP® Products	<a href="http://www.dlp.com">www.dlp.com</a>
DSP	<a href="http://dsp.ti.com">dsp.ti.com</a>
Clocks and Timers	<a href="http://www.ti.com/clocks">www.ti.com/clocks</a>
Interface	<a href="http://interface.ti.com">interface.ti.com</a>
Logic	<a href="http://logic.ti.com">logic.ti.com</a>
Power Mgmt	<a href="http://power.ti.com">power.ti.com</a>
Microcontrollers	<a href="http://microcontroller.ti.com">microcontroller.ti.com</a>
RFID	<a href="http://www.ti-rfid.com">www.ti-rfid.com</a>
OMAP Applications Processors	<a href="http://www.ti.com/omap">www.ti.com/omap</a>
Wireless Connectivity	<a href="http://www.ti.com/wirelessconnectivity">www.ti.com/wirelessconnectivity</a>

### Applications

Automotive and Transportation	<a href="http://www.ti.com/automotive">www.ti.com/automotive</a>
Communications and Telecom	<a href="http://www.ti.com/communications">www.ti.com/communications</a>
Computers and Peripherals	<a href="http://www.ti.com/computers">www.ti.com/computers</a>
Consumer Electronics	<a href="http://www.ti.com/consumer-apps">www.ti.com/consumer-apps</a>
Energy and Lighting	<a href="http://www.ti.com/energy">www.ti.com/energy</a>
Industrial	<a href="http://www.ti.com/industrial">www.ti.com/industrial</a>
Medical	<a href="http://www.ti.com/medical">www.ti.com/medical</a>
Security	<a href="http://www.ti.com/security">www.ti.com/security</a>
Space, Avionics and Defense	<a href="http://www.ti.com/space-avionics-defense">www.ti.com/space-avionics-defense</a>
Video and Imaging	<a href="http://www.ti.com/video">www.ti.com/video</a>
<b>TI E2E Community</b>	<a href="http://e2e.ti.com">e2e.ti.com</a>