

## CLC016 Data Retiming PLL with Automatic Rate Selection

Check for Samples: [CLC016](#)

### FEATURES

- Retimed Data Output
- Recovered Clock Output
- Auto and Manual Rate Select Modes
- Four User-Configurable Data Rates
- No Potentiometers Required
- External Loop Bandwidth Control
- Frequency Detector for Lock Acquisition
- Carrier Detect Output
- Output MUTE Function
- Single Supply Operation: +5V or –5.2V
- Low Cost

### APPLICATIONS

- **SMPTE 259M Serial Digital Interfaces:** NTSC/PAL, 4:2:2 Component, 360 Mbps Wide Screen
- **Serial Digital Video Routing and Distribution**
- **Clock and Data Recovery for High-Speed Data Transmission**
- **Re-Synchronization of Serial Data for SONET/SDH, ATM, CAD Networks, Medical and Industrial Imaging**

### KEY SPECIFICATIONS

- **Low Jitter: 130 ps<sub>pp</sub> @ 270 Mbps, 0.25% Fractional Loop Bandwidth (0.675 MHz)**
- **High Data Rates: 40 Mbps – 400 Mbps**
- **Low Supply Current: 100 mA, Including Output Biasing**
- **Low Supply Current: 100 mA, Including Output Biasing**
- **Flexible Fractional Loop Bandwidth: from 0.05% to 0.5%**

### DESCRIPTION

TI's Comlinear CLC016 is a low-cost, monolithic, data retiming phase-locked loop (PLL) designed for high-speed serial clock and data recovery. The CLC016 simplifies high-speed data recovery in multi-rate systems by incorporating auto-rate select (ARS) circuitry on chip. This function allows the user to configure the CLC016 to recognize up to four different data rates and automatically adjust to provide accurate, low-jitter clock and data recovery. A single resistor is used to set each data rate anywhere between 40 Mbps and 400 Mbps. No potentiometers, crystals, or other external ICs are required to set the rate.

The CLC016 has output jitter of only 130 ps<sub>pp</sub> at a 270 Mbps data rate and 0.25% fractional loop bandwidth. Low phase detector output offset and low VCO injection combine to ensure that the CLC016 does not generate bit errors or large phase transients in response to extreme fluctuations in data transition density. The result is improved performance when handling the pathological patterns inherent in the SMPTE 259M video industry standard.

The carrier detect and output mute functions may be used together to automatically latch the outputs when no data is present, preventing random transitions. The external loop filter allows the user to tailor the loop response to the specific application needs. The CLC016 will operate with either +5V or –5.2V power supplies. The serial data inputs and outputs, as well as the recovered clock outputs, allow single- or differential-ECL interfacing. The logic control inputs are TTL-compatible.



Please be aware that an important notice concerning availability, standard warranty, and use in critical applications of Texas Instruments semiconductor products and disclaimers thereto appears at the end of this data sheet.

All trademarks are the property of their respective owners.

### Output Data and Clock, Differential

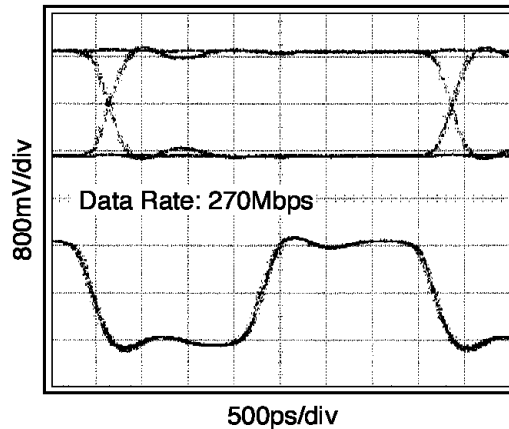

### Typical Application

Figure 1. Four-Rate Clock and Data Recovery with Automatic Rate Selection - PLCC Package shown

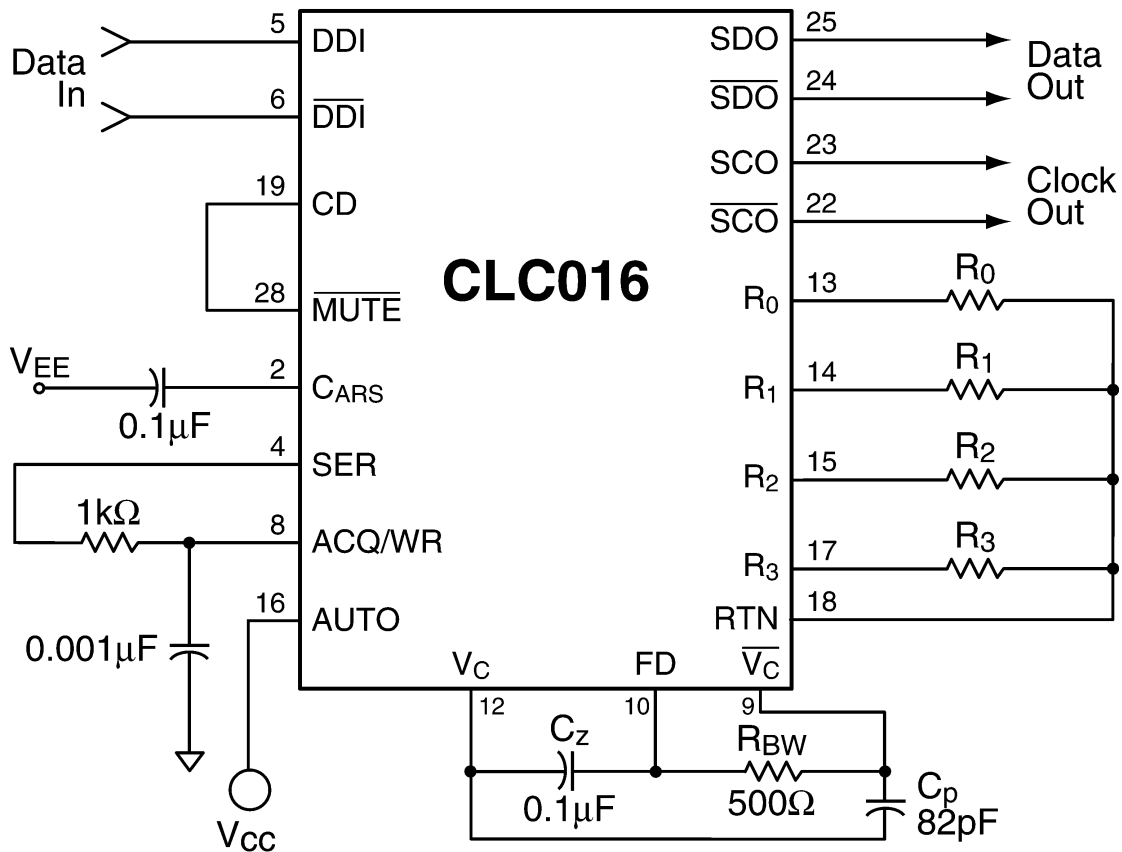

Connection Diagrams

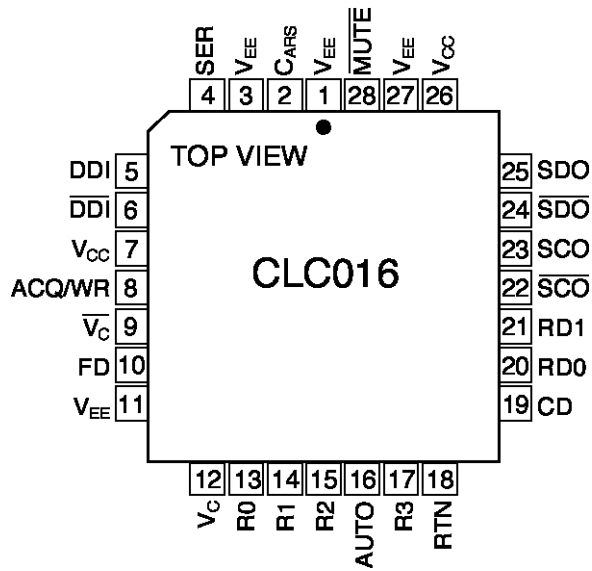

Figure 2. 28-Pin PLCC  
See FNC Package

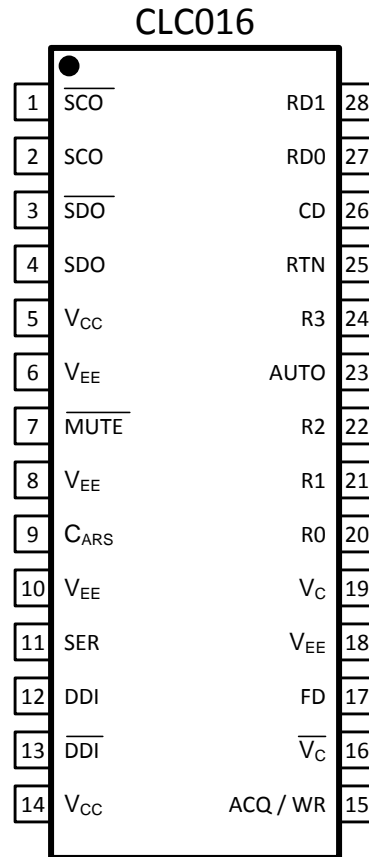

Figure 3. 28-Pin TSSOP  
See PW Package



These devices have limited built-in ESD protection. The leads should be shorted together or the device placed in conductive foam during storage or handling to prevent electrostatic damage to the MOS gates.

### Absolute Maximum Ratings<sup>(1)(2)</sup>

Supply Voltage ( $V_{CC}-V_{EE}$ )		-0.3, +6.0V
Maximum Junction Temperature		+150°C
Storage Temperature Range		-65°C to +150°C
Lead Temperature (Soldering 4 sec)		+260°C
ESD Rating <sup>(3)</sup>		2kV
Package Thermal Resistance	$\theta_{JA}$ 28-Pin PLCC	85°C/W
	$\theta_{JA}$ 28-Pin TSSOP	90°C/W
	$\theta_{JC}$ 28-Pin PLCC	35°C/W
	$\theta_{JC}$ 28-Pin TSSOP	14°C/W
Reliability Information MTTF (based on limited life test data)		$2.6 \times 10^7$ hours

- (1) Absolute Maximum Ratings are those values beyond which the safety of the device cannot be ensured. They are not meant to imply that the devices should be operated at these limits. The table of [Electrical Characteristics](#) specifies conditions of device operation.
- (2) If Military/Aerospace specified devices are required, please contact the TI Sales Office/ Distributors for availability and specifications.
- (3) Human body model, 1.5 k $\Omega$  in series with 100 pF.

### Recommended Operating Conditions

Supply Voltage ( $V_{CC}-V_{EE}$ )		4.5V to 5.5V
Operating Temperature	CLC016AC	0°C to +70°C
	CLC016AJ,CLC016	-40°C to +85°C
Jitter Transfer Function Fractional Loop Bandwidth		0.05% to 0.5%
$SCO/\overline{SCO}$ , $SDO/\overline{SDO}$ Minimum Voltage <sup>(1)</sup>		$V_{CC} - 1.6V$

- (1) To maintain specified performance,  $SCO/\overline{SCO}$  and  $SDO/\overline{SDO}$  should not drop below this level.

## Electrical Characteristics

( $V_{CC} = 0V$ ,  $V_{EE} = -5V$ ,  $R_{BW} = 500\Omega$ ;  $C_Z = 0.1 \mu F$ ;  $C_P = 82 pF$ ;  $R_n = 3504$ ,  $C_{ARS} = 0.1 \mu F$ ; unless specified).

Parameter	Conditions	Typ +25°C	Min/Max +25°C <sup>(1)</sup>	Min/Max Full Temp. Range <sup>(1)</sup>	Units	
<b>DYNAMIC PERFORMANCE</b>						
Residual Jitter	270 Mbps PRN sequence, <sup>(2)(3)</sup>	150	250	300	ps <sub>pp</sub>	
Acquisition Time	270 Mbps PRN sequence	$6 \times 10^5$			bit cells	
Minimum Average Data Rate, $f_{CLK}$ Full Temperature Range	$4.5V \leq (V_{CC} - V_{EE}) \leq 5.5V$ <sup>(2)</sup>			100	Mbps	
Minimum Average Data Rate, $f_{CLK}$ 0 to 70°	$4.5V \leq (V_{CC} - V_{EE}) \leq 5.5V$	40			Mbps	
Maximum Average Data Rate, $f_{CLK}$	$4.5V \leq (V_{CC} - V_{EE}) \leq 5.5V$ <sup>(2)</sup>		400	400	Mbps	
Tracking and Capture Range	$4.5V \leq (V_{CC} - V_{EE}) \leq 5.5V$ <sup>(2)(4)</sup>	$\pm 8.3$	$\pm 5.0/\pm 13.0$	$\pm 2.5/\pm 18.0$	% $f_{CLK}$	
VCO Power Supply Sensitivity	See <sup>(2)</sup>	$\pm 0.8$	$\pm 1.2$	$\pm 1.3$	%V	
VCO Temperature Sensitivity		$\pm 250$			ppm/°C	
Jitter Transfer Function –3 dB bandwidth (Fractional Loop Bandwidth), $\lambda_{BW}$	$R_{BW} = 100\Omega$ <sup>(5)(6)</sup>	0.05			% $f_{CLK}$	
	$R_{BW} = 500\Omega$ <sup>(5)(6)</sup>	0.25			% $f_{CLK}$	
	$R_{BW} = 1000\Omega$ <sup>(5)(6)</sup>	0.5			% $f_{CLK}$	
Jitter Transfer Function Peaking	$R_{BW} = 500\Omega$ , 270 Mbps <sup>(5)</sup>	<0.1			dB	
<b>STATIC PERFORMANCE</b>						
Power Supply Current, $I_{EE}$	See <sup>(2)</sup>	105	125	133	mA	
Voltage on Selected $R_n$ Resistor	See <sup>(7)</sup>	$V_{CC}$ –2.2			V	
Voltage on Unselected $R_n$ Resistor	See <sup>(7)</sup>	$V_{CC}$			V	
$V_C/\sqrt{C}$ Common-Mode Voltage, $V_{CM}$	See <sup>(7)</sup>	$V_{CC}$ –1.5			V	
$V_C/\sqrt{C}$ Diff-Mode Voltage Range, $V_{DM}$	See <sup>(7)</sup>	$\pm 300$			mV	
DDI/DDI	Input Range Upper Limit, $V_H$	See <sup>(2)</sup>	3	$V_{CC}$	V	
	Input Range Lower Limit, $V_L$			$V_{EE} + 2.5$	V	
	Minimum Differential Input Amplitude, $V_\Delta$			200	200	mV
	Input Current			6	6	$\mu A$
SCO/ $\overline{SCO}$ , SDO/ $\overline{SDO}$	Output Current, $I_{OUT}$	See <sup>(2)</sup>	11	9.3/12	8.6/12.7	mA
	Output Voltage Swing, $V_{OUT}$	$R_{collector} = 75\Omega$ <sup>(2)</sup>	725	625/900		mV
ACQ/WR, $\overline{MUTE}$ , RDO/RD1	Voltage Input — LOW, $V_{IL}$	See <sup>(8)</sup>		$V_{EE} + 0.8$	$V_{EE} + 0.8$	V
	Voltage Input — HIGH, $V_{IH}$	See <sup>(2)</sup>		$V_{EE} + 2.0$	$V_{EE} + 2.0$	V
	Input Current ( $I_{IN}$ )	See <sup>(2)</sup>		$\pm 100$	$\pm 500$	nA

(1) Min/Max ratings are based on product characterization and simulation. Individual parameters are tested as noted. Outgoing quality levels are determined from tested parameters.

(2) J-level spec. is 100% tested at +25°C.

(3) Peak-to-peak jitter is defined as 6 times the rms jitter.

(4) Tracking and capture range are specified as a percentage of the input data rate  $f_{CLK}$ . The minimum and maximum are specified so long as  $R_n$  has been chosen according to the equation in [Resistor Selection for Data Rates](#).

(5) Average data transition density of 1 transition per 2 bit cells.

(6) When the value of  $R_{BW}$  changes it is necessary to also change the values of  $C_P$  and  $C_Z$ . See [Loop Filter Design](#).

(7) This information is provided for system troubleshooting purposes only.

(8) RD0/RD1 are inputs when AUTO = 0 and outputs when AUTO = 1.

**Electrical Characteristics (continued)**

( $V_{CC} = 0V$ ,  $V_{EE} = -5V$ ,  $R_{BW} = 500\Omega$ ;  $C_Z = 0.1 \mu F$ ;  $C_P = 82 pF$ ;  $R_n = 3504$ ,  $C_{ARS} = 0.1 \mu F$ ; unless specified).

Parameter		Conditions	Typ +25°C	Min/Max +25°C <sup>(1)</sup>	Min/Max Full Temp. Range <sup>(1)</sup>	Units
CD, UNL, RDO/RD1	Current Output — LOW, $I_{OL}$	$V_{OL} \leq V_{EE} + 0.5V^{(8)}$	800			$\mu A$
	Current Output — HIGH, $I_{OH}$	$V_{OH} \geq V_{CC} - 0.5V^{(8)}$	-700			$\mu A$
<b>TIMING PERFORMANCE</b>						
Delay: SCO to SDO, $t_d$			200			ps
SCO Duty Cycle		See <sup>(2)</sup>	50	44/56	44/56	%
Rise/Fall Time: SCO, SDO, $t_r/t_f$		20%–80%, $R_{collector} = 75\Omega$ <sup>(9)</sup>	230			ps
SDO Duty Cycle Distortion			35			ps
Minimum Setup Time: RDO/RD1 to ACQ/WR, $t_{SU}$			4	20	20	ns
Minimum Hold Time: ACQ/WR to SS1/SS0, $t_h$			3	20	20	ns
Minimum Pulse Width: ACQ/WR, $t_w$			5	20	20	ns
ARS Oscillator Period, $t_{OSC}$		See <sup>(2)</sup>	10.5	8.5/15.5		ms
CD Pulse Width, $t_{PW}$		See <sup>(10)</sup>	1			$\mu s$
$\overline{MUTE}$ Response Time, $t_M$			5			ns

(9) Includes typical pc board capacitance.

(10) The CD circuit is a retriggerable one-shot which retriggers on every data transition.

Typical Performance Characteristics

Output Data and Clock, Differential

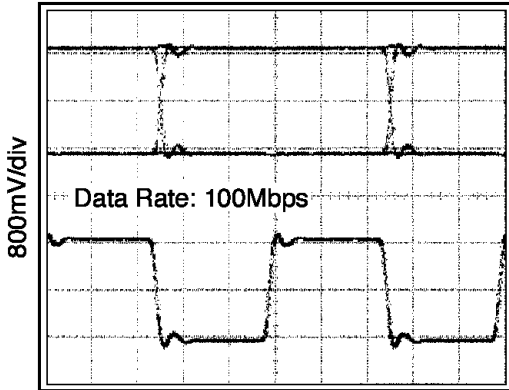

2ns/div  
Figure 4.

Output Data and Clock, Differential

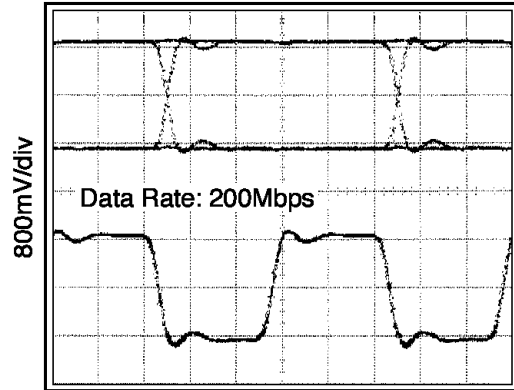

1ns/div  
Figure 5.

Output Data and Clock, Differential

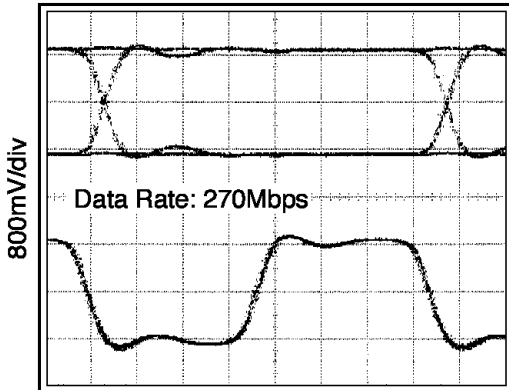

500ps/div  
Figure 6.

Output Data and Clock, Differential

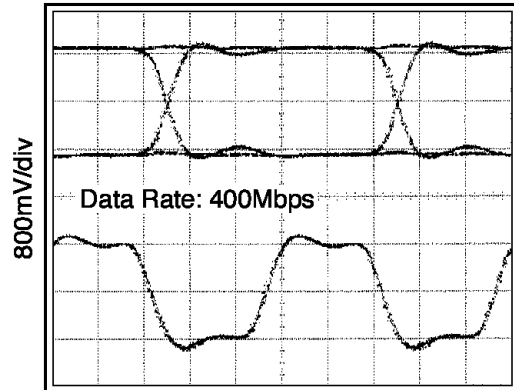

500ps/div  
Figure 7.

Jitter Transfer Function, 100Mbps

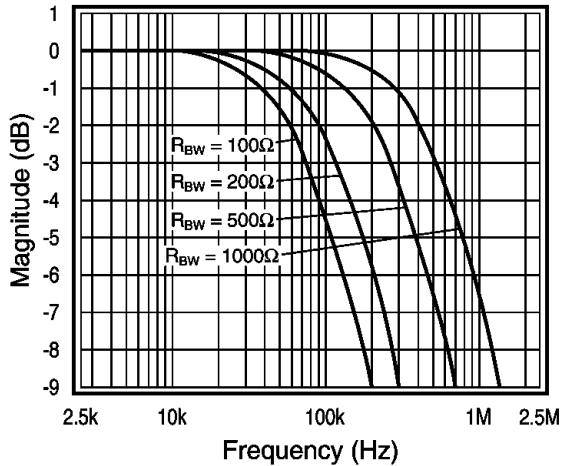

Figure 8.

Jitter Transfer Function, 200Mbps

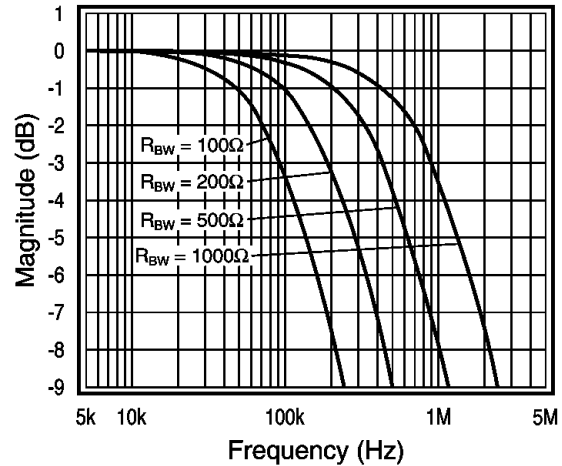
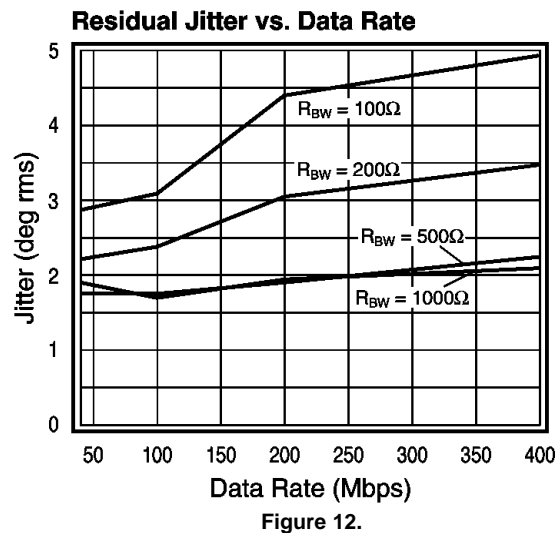
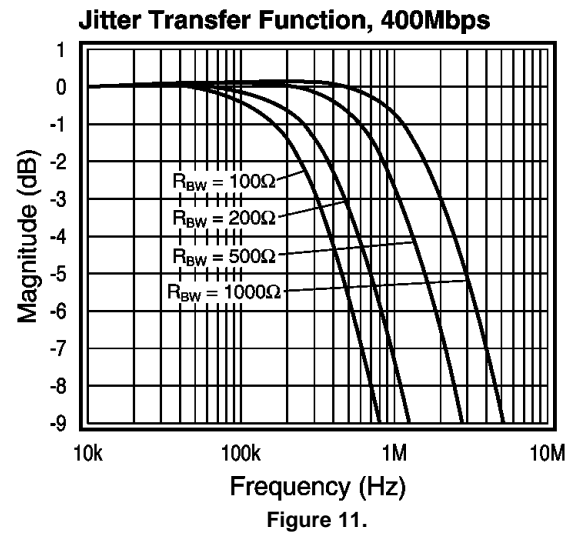
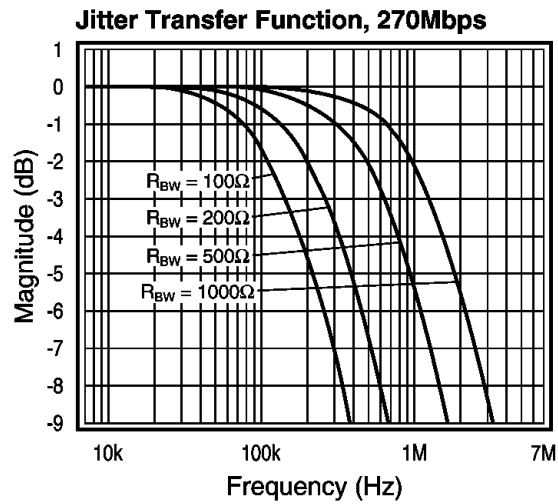

Figure 9.

### Typical Performance Characteristics (continued)



## Product Description

The CLC016 Data Retiming PLL is a monolithic circuit that recovers clock and data from a serial NRZ or NRZI data stream. The Data Retiming PLL incorporates an Auto-Rate Selection function which automatically selects one of four user-configurable data rates. The following outline lists the material covered in this data sheet:

- Typical schematics for +5V or -5.2V operation
- Block diagram description
- Pin definitions
- Design guidelines
- Interface connections
- Measurement
- Typical applications
- Printed circuit layout and evaluation boards



**DATA RETIMER TYPICAL CONNECTIONS**

The CLC016 schematics provided in [Figure 13](#) and [Figure 14](#) show typical +5V or –5.2V connections with Auto-Rate Selection configured for SMPTE 259M standard video data rates: 143, 177, 270 and 360 Mbps. The section [Resistor Selection for Data Rates](#) gives tables and equations for determining  $R_n$  resistor values for any data rate from 50 Mbps to 400 Mbps. A resistor value table is also given for SONET/SDH data rates. The schematics in [Figure 13](#) and [Figure 14](#) do not include input termination. The high impedance inputs on the CLC016 allow the user to define the termination. The [Interfaces](#) section suggests recommended terminations for the inputs and outputs of the CLC016.

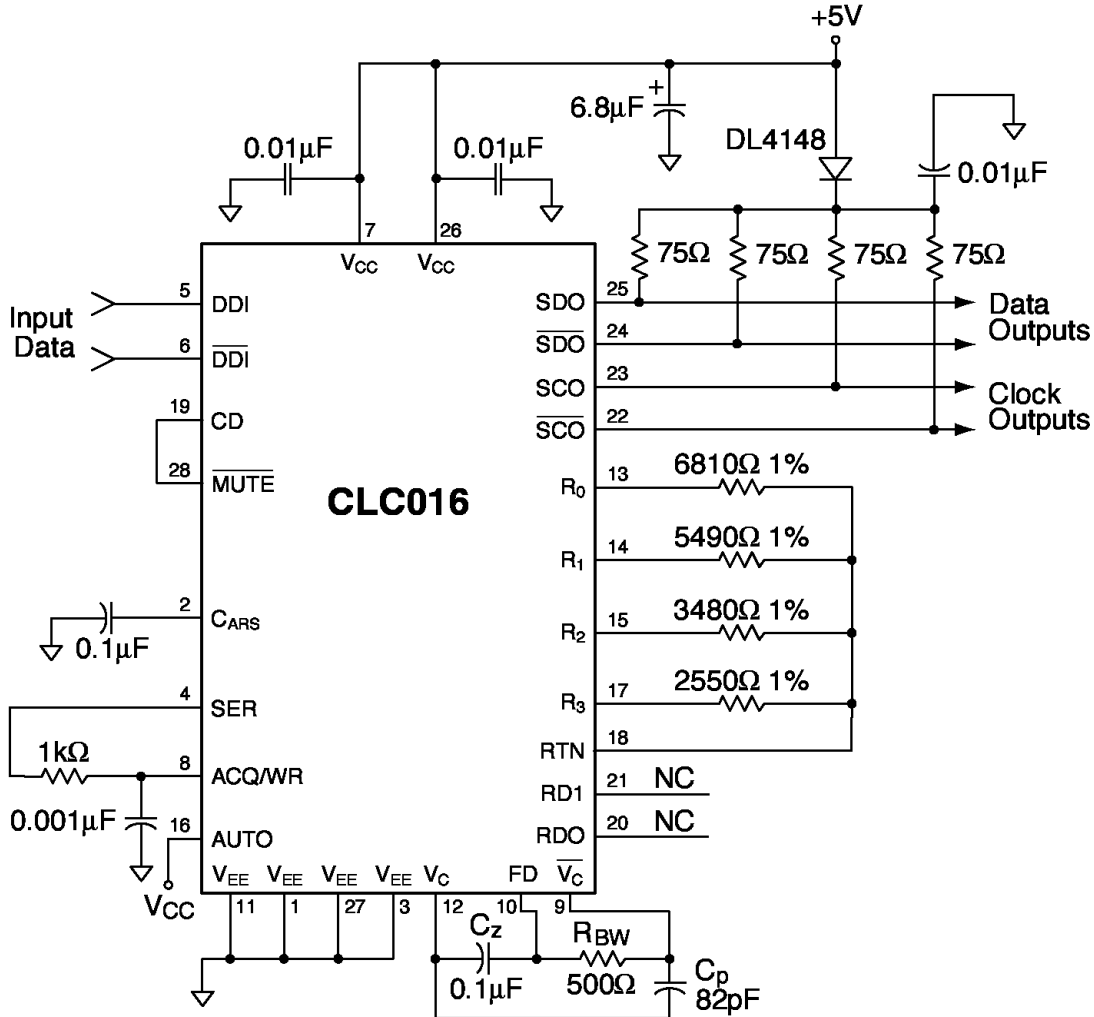

**Figure 13. Typical +5V Connection - PLCC Package shown**

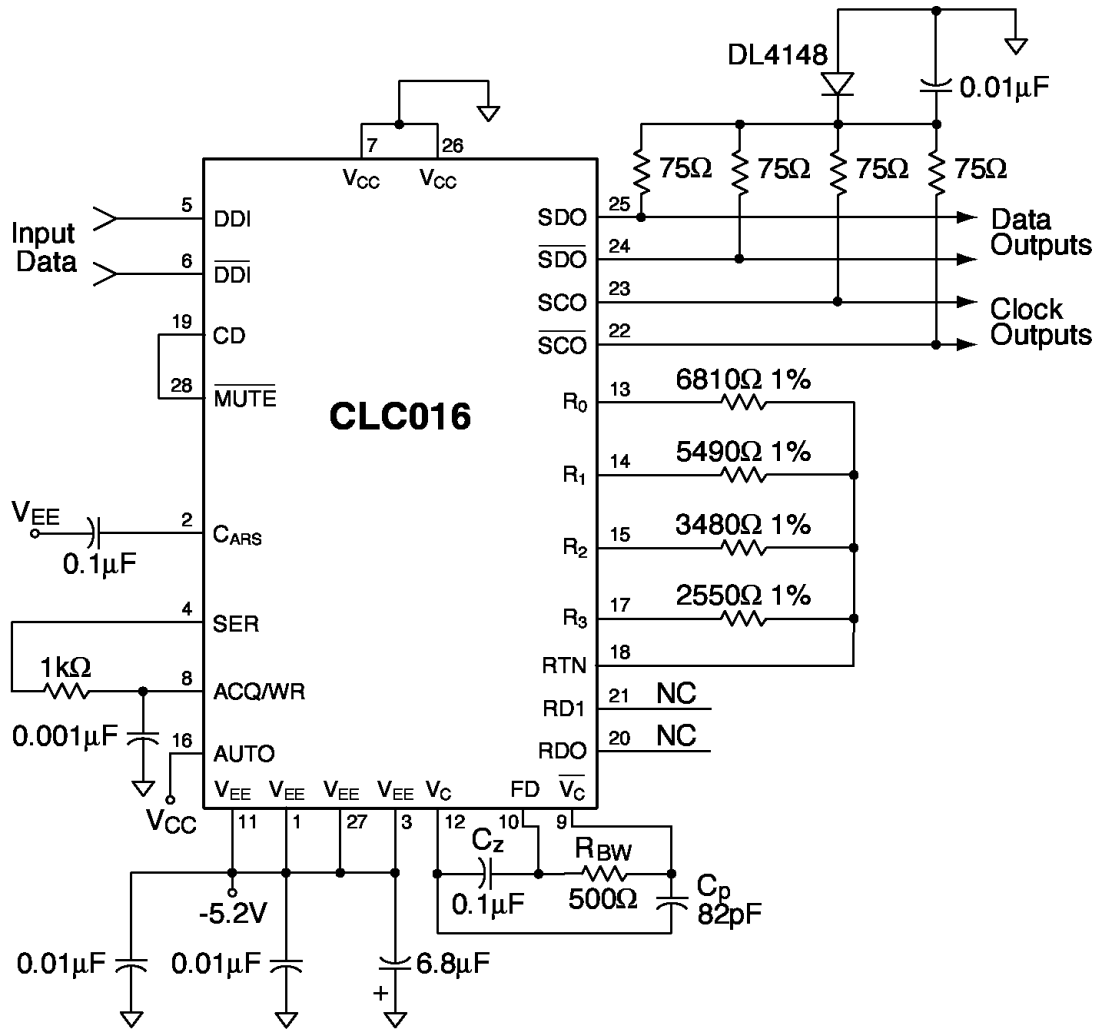

Figure 14. Typical -5.2V Connection - PLCC Package shown

**PIN DESCRIPTIONS**

Name	Pin # PLCC	Pin # TSSOP	Description
DDI, $\overline{\text{DDI}}$	5, 6	12, 13	Differential (ECL, PECL) data inputs.
SCO, $\overline{\text{SCO}}$	23, 22	2, 1	Differential collector (ECL, PECL compatible) clock outputs
SDO, $\overline{\text{SDO}}$	25, 24	4, 3	Differential collector (ECL, PECL compatible) retimed data outputs
RDO, RD1	20, 21	27, 28	Bi-directional (TTL, CMOS) VCO data rate bus. See <a href="#">Table 4</a> for state table.
R <sub>n</sub>	13, 14, 15, 17	20, 21, 22, 24	VCO rate configuration resistors (n = 0, 1, 2, 3).
RTN	18	25	Return for R <sub>n</sub>
SER	4	11	Loop unlock output (TTL, CMOS) indicator. High when loop is unlocked or harmonic-locked.
CD	19	26	Carrier detector (TTL, CMOS) output. Low when no signal is present.
$\overline{\text{MUTE}}$	28	7	Output mute (TTL, CMOS) control. Connect to CD to latch outputs when no signal is present.
AUTO	16	23	Auto- or manual-rate mode control (TTL, CMOS) input. Assert high for auto-rate mode.
ACQ/WR	8	15	ARS oscillator enable and rate latch enable (TTL, CMOS) input. Connect to SER (see diagrams) for auto-rate mode.
C <sub>ARS</sub>	2	9	External capacitor connections for controlling the rate of the ARS search.
V <sub>C</sub> , $\overline{\text{V}}_{\text{C}}$	12, 9	19, 16	VCO control lines. Loop filter connects across these and FD.
FD	10	17	Frequency detector output. C <sub>Z</sub> must connect from FD to V <sub>C</sub> .
V <sub>CC</sub>	7, 26	5, 14	Positive supply pins (ground or +5V).
V <sub>EE</sub>	1, 3, 11, 27	6, 8, 10, 18	Negative supply pins (–5.2V or ground).

## OPERATION DESCRIPTION

The CLC016 Data Retiming PLL, [Figure 15](#), has three main functions: Frequency Detector (FD), Phase-Locked Loop (PLL) and Auto-Rate Select (ARS).

The Frequency Detector detects the frequency difference between the input data rate and the VCO frequency, and forces a rapid change in VCO frequency to minimize that difference. As the frequency difference approaches zero, the PLL acquires phase lock and the Frequency Detector becomes inactive. In Auto-Rate Select mode, the Frequency Detector requests the ARS function to search for a new data rate.

The PLL consists of a Voltage Controlled Oscillator (VCO), a Phase Detector (PD), and an external Loop Filter (LF). The PLL recovers a low-jitter clock for data retiming. The data is re-synchronized (retimed) at the Data Latch. The data and clock are buffered outputs.

The ARS block has two modes of operation: Auto-Rate Mode (ARM) and Manual-Rate Mode (MRM). Once the ARS function is activated (ARM), it sequences through the user-selected data rates until phase lock is achieved. The user has control over the rate at which ARS steps through the data rates (see [Auto-Rate Selection](#) section).

The Carrier Detect (CD) block detects the presence of input data and is an input to the ARS block. When CD is connected to MUTE and no data is present, the clock and data outputs are latched.

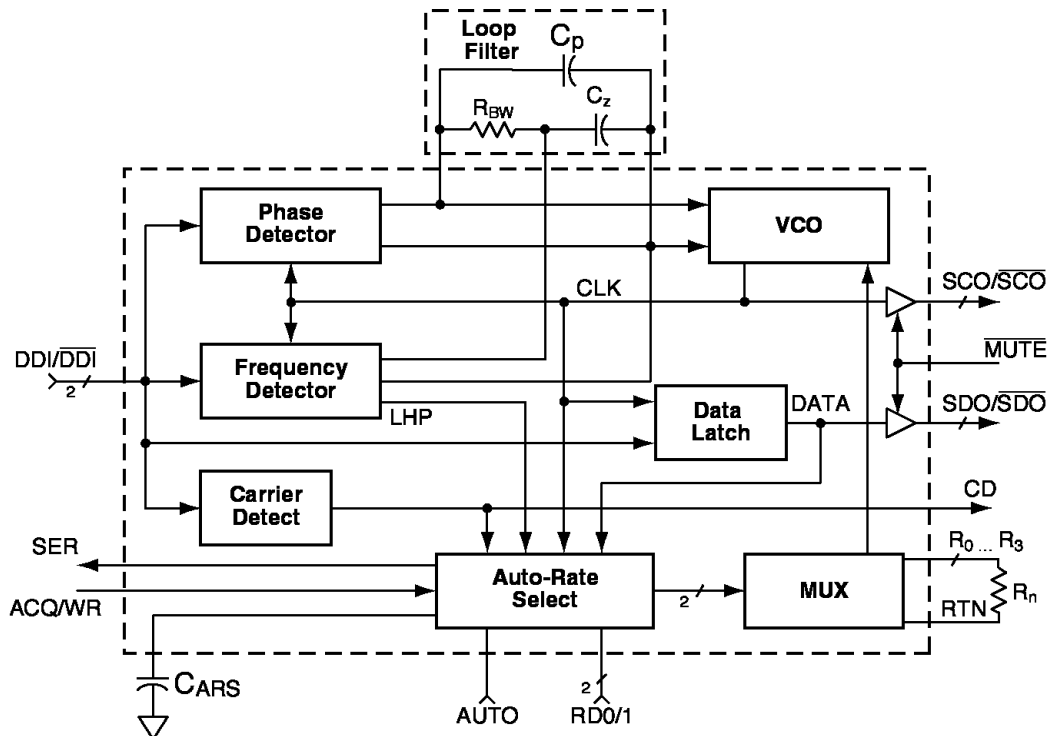

Figure 15. Functional Block Diagram

## FUNCTIONAL BLOCK DESCRIPTIONS

### Frequency Detector (FD)

The Frequency Detector detects the difference between VCO rate and the input data rate, then forces the frequency (rate) difference to zero. In Auto-Rate Mode, when a difference is detected, FD requests the ARS block to start a search to match the rate. Once the PLL acquires phase lock, the PLL takes control and the FD goes inactive.

### Phase Detector (PD)

The PD compares the phase of the VCO to the phase of the input data. The PD output is a differential current which is proportional to the phase error. The PD gain has units of amperes per radian and is dependent upon the data transition density ( $\rho$ ). The data transition density is defined as the average number of data transitions per clock cycle, and is bounded by  $0 \leq \rho \leq 1$ . The PD output is connected to the VCO through the external loop filter network. This network translates the PD output current to a voltage that controls the VCO.

### Loop Filter (LF)

The external Loop Filter shown in [Figure 15](#) is made up of passive components  $R_{BW}$ ,  $C_Z$ , and  $C_P$ . This external loop filter controls the PLL dynamics and acquisition time.

The Frequency Detector supplies its signal to the  $C_Z$  capacitor, and takes control of the VCO under the condition of frequency unlock. The selection of the filter components is covered in the [Loop Filter Design](#) section.

### Voltage Controlled Oscillator (VCO)

The VCO is a temperature-compensated, factory-trimmed multivibrator that requires no external capacitors for tuning. It is stable over temperature and power supply variations. This eliminates the need for potentiometers to adjust each of the VCO center frequencies to correspond with the input data rates. Instead, an external resistor ( $R_n$ ) is used to set each of four data rates in the range of 40 Mbps to 400 Mbps.

### Carrier Detector (CD)

The CD circuit is a retriggerable one-shot which retriggers on every data transition. When data transitions occur at a rate  $\geq 1$  transition per  $\mu\text{s}$ , CD indicates the presence of data at the input pins  $\overline{\text{DDI}}$  and  $\overline{\text{DDI}}$ . CD also inputs a signal to ARS that inhibits any rate search from occurring in the absence of input data. When CD is connected to the MUTE pin, and no data is present, the output clock (SCO,  $\overline{\text{SCO}}$ ) and data (SDO,  $\overline{\text{SDO}}$ ) lines are latched.

### Auto-Rate Select (ARS) and Multiplexer (MUX)

The ARS, in conjunction with the MUX, sequences through the user-configured resistor values ( $R_n$ ) in an unlocked condition. The ARS has two modes: Auto-Rate Mode (ARM) and Manual-Rate Mode (MRM). It incorporates additional features and functions that are discussed in the section named [Auto-Rate Selection](#).

When ARS is in Auto-Rate Mode, its inputs are the FD (the LHP control line), the Carrier Detect (CD), the VCO (CLK), and Latched Data output. These input signals produce an external Search (SER) signal that, when connected to the ACQ/WR input, enables the ARM operation. A single capacitor,  $C_{ARS}$ , sets the ARM sequence time for stepping through the different user-configured data rates.

The timing section of the ARS block controls the digital input analog multiplexer (MUX). Under the control of ARS, the MUX steps through each data rate starting with the previously-selected resistor  $R_n$  and incrementing to  $R_{n+1}$ , etc. in order of  $R_0, R_1, R_2, R_3, R_0, \dots$ . This sequence is repeated until lock is achieved. The 2-bit bidirectional bus, comprised of RD0 and RD1, indicates the selected data rate. The RD0, RD1 bidirectional bus is set to output mode when AUTO is active (high). Therefore, RD0, RD1 can be monitored when AUTO is active. When no data is present at the inputs, CD will inhibit the ARM.

In manual mode the RD0, RD1 lines are set to input mode. Therefore, RD0, RD1 cannot be monitored when AUTO is inactive. The selection of external components for both modes of operation is discussed in sections, [Resistor Selection for Data Rates](#), and [Auto-Rate Selection](#).

## DESIGN GUIDELINES

### Resistor Selection for Data Rates

The CLC016 Data Retiming PPL supports 4 different data rates using user-selected resistors that set the VCO center frequency. The resistors found in [Figure 13](#), [Figure 14](#) are identified by the reference designators  $R_n$ , where  $n$  is 0, 1, 2 and 3.

It is recommended that the user select resistor values with tolerances of 1% and temperature coefficients of  $\leq 100$  ppm/ $^{\circ}\text{C}$ . Refer to [Table 1](#) and [Table 2](#) for calculated resistor values for SMPTE and SONET standards. Resistors for other data rates are determined from the following equation:

$$R_n = \left( \frac{1000 \text{ Mbps}}{f_{\text{CLK}}} - 0.2 \right) \cdot 1 \text{ k}\Omega$$

where

- $n = 0, 1, 2, 3$  and  $f_{\text{CLK}}$  is the desired data rate. (1)

**Table 1. Resistor Values for SMPTE 259M Data Rates**

Data Rate (Mbps)	Ref. Des. (in <a href="#">Figure 13</a> , <a href="#">Figure 14</a> ) $R_n$	Calculated Resistor (k $\Omega$ )	1% Resistors (in <a href="#">Figure 13</a> , <a href="#">Figure 14</a> ) (k $\Omega$ )
143	$R_0$	6.79	6.81
177	$R_1$	5.45	5.49
270	$R_2$	3.50	3.48
360	$R_3$	2.58	2.55

**Table 2. DS-3 and SONET/SDH Resistor Values**

Data Rate (Mbps)	Calculated Resistor (k $\Omega$ )	1% Resistors (k $\Omega$ )
44.7	22.1	22.1
51.84	19.1	19.1
155.52	6.23	6.19
311.04	3.02	3.01

### Loop Filter Design

The function of the PLL is to low-pass filter the jitter of the incoming data stream. The jitter transfer function for the PLL (or the phase transfer function) is set by the phase detector gain, the loop filter transfer function, and the VCO gain. These elements are shown in the small-signal block diagram, [Figure 16](#).

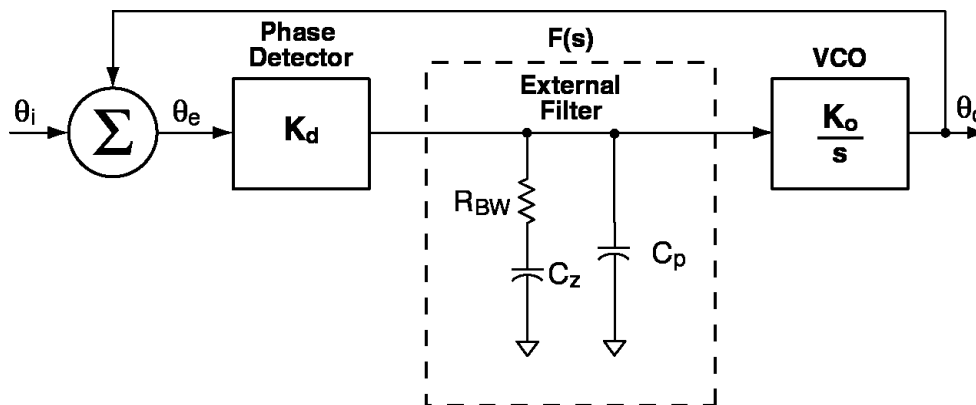

**Figure 16. PLL Loop**

The jitter transfer function is the small signal transfer function,  $\theta_o/\theta_i$ , and is given by:

$$\frac{\theta_o}{\theta_i} = \frac{2\pi f_{BW}(s + 2\pi f_z)}{s^2 + s2\pi f_{BW} + 4\pi^2 f_{BW}f_z}$$

where

- $f_{BW}$  is the PLL bandwidth and  $f_z$  is a zero in the closed loop transfer function. (2)

The phase detector gain and VCO gain are fixed internally. Selection of the external loop filter components defines the overall jitter transfer function. Additionally, the filter components control the acquisition performance of the PLL.

A Bode plot for the closed loop PLL jitter transfer function is shown in Figure 17.

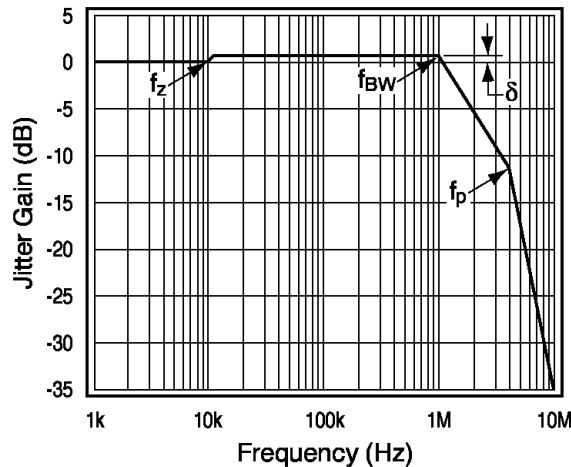

Figure 17. Closed-Loop Transfer Function

At frequencies above  $f_{BW}$  (the PLL bandwidth) the jitter is attenuated. At frequencies below  $f_{BW}$  the jitter is transmitted through the PLL. A small amount of jitter peaking ( $\delta$ ) occurs at frequencies below  $f_{BW}$ . The amount of peaking increases when  $f_z$  moves closer to  $f_{BW}$ .

### Setting the Loop Bandwidth (Selecting $R_{BW}$ )

The fractional loop bandwidth,  $\lambda_{BW}$ , is the ratio of  $f_{BW}$  to the data rate. The CLC016 is specified for operation with fractional loop bandwidths ranging from 0.05% to 0.5%. For example, if the loop bandwidth is 1 MHz and the data rate is 270 Mbps, then the fractional loop bandwidth is:

$$\lambda_{BW} = \frac{f_{BW}}{f_{CLK}} = \frac{1 \text{ MHz}}{270 \text{ Mbps}} = 0.0037 \text{ or } 0.37\% \quad (3)$$

The fractional loop bandwidth is set by the loop component  $R_{BW}$ :

$$\lambda_{BW} = \left(\frac{\rho}{2\pi}\right) \frac{R_{BW}}{16.67 \text{ k}\Omega}$$

where

- $\rho$  is the data transition density in average number of data transitions per bit cell, and ranges in value from 0 to 1. For example, if a pseudo-random data stream is used, the value of  $\rho$  is 1/2, and a data transition will occur once every two bit cells on the average. The phase detector and VCO gain set the constants in the equation. (4)

If the value of  $R_{BW}$  is 500 $\Omega$  and  $\rho = 1/2$ , the fractional loop bandwidth is:

$$\lambda_{BW} = \left(\frac{0.5}{2\pi}\right) \frac{500\Omega}{16.67 \text{ k}\Omega} = 0.0024 \text{ or } 0.24\% \quad (5)$$

For a data rate of 270 Mbps this corresponds to a loop bandwidth  $f_{BW} = 644 \text{ kHz}$ . The jitter at frequencies above 644 kHz will be attenuated by the PLL.

The equation may be rearranged to obtain  $R_{BW}$  as a function of the desired fractional loop bandwidth:

$$R_{BW} = \frac{2\pi\lambda_{BW} \cdot 16.67 \text{ k}\Omega}{\rho} \quad (6)$$

### Setting the Jitter Peaking Factor (Selecting $C_Z$ )

The jitter peaking factor,  $\delta$ , is set by the ratio of the critical frequencies  $f_Z$  and  $f_{BW}$ . The ratio is defined as:

$$\alpha = \frac{f_Z}{f_{BW}} \quad (7)$$

Figure 18 shows how the jitter peaking factor,  $\delta$ , varies with  $\alpha$ . For example, if the value of  $\alpha$  is 0.1, then the jitter peaking is about 0.6 dB.

The approximation for the required value of  $\alpha$  to obtain a given amount of jitter peaking is:

$$\alpha \approx \delta(0.134 + 0.058\delta) \quad (8)$$

The critical frequency  $f_Z$  is:

$$f_Z = \frac{1}{(2\pi C_Z R_{BW})} \quad (9)$$

Select  $C_Z$  by the following equation:

$$C_Z = \frac{1}{2\pi\alpha R_{BW} f_{BW}} \quad (10)$$

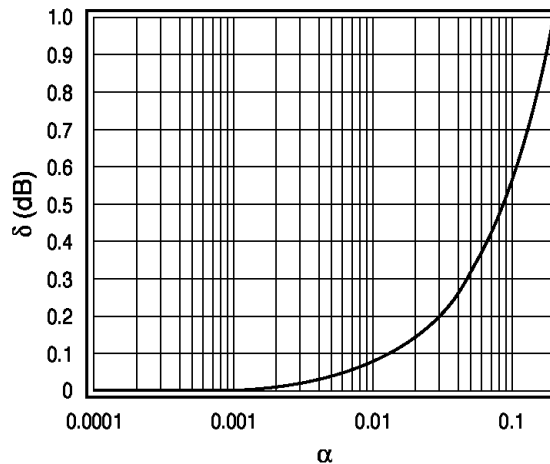

**Figure 18. Jitter Peaking Curve**

As an example, assume that the amount of jitter peaking that can be tolerated is 0.05 dB. From the jitter peaking design equation (or from Figure 18) the required value of  $\alpha$  is:

$$\alpha \approx 0.05[0.134 + (0.058)(0.05)] = 0.007 \quad (11)$$

Now assuming that the loop bandwidth is 644 kHz and that the value of  $R_{BW}$  is 500 $\Omega$ , the value of  $C_Z$  is:

$$C_Z = \frac{1}{2\pi \cdot 0.007 \cdot 500 \cdot 644 \cdot 10^3} = 0.07 \mu\text{F} \quad (12)$$

The value of  $C_Z$  also affects the acquisition performance of the PLL. Estimate the acquisition time with the following equation:

$$t_{ACQ} \cdot f_{CLK} \leq \frac{C_Z}{0.14 \text{ pF}} \quad (13)$$

where  $t_{ACQ} \times f_{CLK}$  is the acquisition time in number of bit cells.



## Selecting $C_P$

Capacitor  $C_P$  establishes a high frequency pole in the loop filter to remove high frequency spectral components from the phase detector. The pole frequency  $f_p$  is:

$$f_p = \frac{1}{2\pi R_{BW} C_P} \quad (14)$$

In general, the pole should be set at least a factor of 4 above the PLL bandwidth,  $f_{BW}$ . Therefore, select  $C_P$  using:

$$C_P = \frac{1}{8\pi R_{BW} f_{BW}} \quad (15)$$

For example, if  $R_{BW}$  is 500 $\Omega$  and  $f_{BW}$  is 644 kHz, then an appropriate value for  $C_P$  is:

$$C_P = \frac{1}{8\pi \cdot 500 \cdot 644 \cdot 10^3} = 125 \text{ pF} \quad (16)$$

Choosing a value for  $C_P$  larger than the value recommended by the selection equation will introduce jitter peaking. Reducing the value of  $C_P$  below that recommended by the selection equation is acceptable, but will result in some increase in jitter. This is most noticeable with large fractional loop bandwidths.

In addition,  $C_P$  can affect the ability of the PLL to acquire lock, especially at high data rates. Because of this, it is recommended to eliminate  $C_P$  entirely for the condition of high data rate (>300 Mbps) combined with narrow loop bandwidth (<0.1%).

## Multiple Rate Considerations

$R_{BW}$  establishes the fractional loop bandwidth. For a fixed value of  $R_{BW}$ ,  $f_{BW}$  will vary with the selected data rate. The location of the critical frequencies  $f_z$  and  $f_p$ , however, are independent of data rate.

To control jitter peaking for all multi-rate application choose:

- the value of  $C_Z$  for the smallest value of  $f_{BW}$  (which is obtained at the lowest data rate).
- the value of  $C_P$  for the largest value of  $f_{BW}$  (which is obtained at the highest data rate).

## Loop Filter Element Summary Table

The [Table 3](#) summarizes the recommended loop filter element values for each of the four SMPTE 259M data rates and a fractional loop bandwidth of 0.25%. The final row of the table gives the recommended values for the multi-rate case, where all four of the SMPTE rates are configured.

**Table 3.**

Data Rate (Mbps)	$f_{BW}$ (kHz)	$R_{BW}$ ( $\Omega$ )	$C_Z$ ( $\mu\text{F}$ )	$C_P$ (pF)
143	358	500	0.10	200
177	443	500	0.10	160
270	675	500	0.047	100
360	900	500	0.04	82
143–360	0.25% $f_{CLK}$	500	0.10	82

## Component Types and Tolerances

It is recommended that  $R_{BW}$  resistors have tolerances of 1% and temperature coefficients of  $\leq 100$  ppm/ $^{\circ}\text{C}$ . The recommended capacitors are ceramic surface mount with 5% tolerance or better.

## AUTO-RATE SELECTION

### Auto Rate Mode (ARM)

This section provides more detail on the ARS sub-system and how to use it. [Figure 19](#) shows a detailed view of the ARS portion of the [Figure 15](#) block diagram

The auto-rate mode is enabled by connecting AUTO to  $V_{CC}$  and SER to ACQ/WRI through the 1 k $\Omega$ /1 nF network. When the VCO is not at the input data rate, SER goes high enabling the ARS oscillator and the Latch. The oscillator increments the 2-bit counter and causes the VCO to sequence through the rates determined by resistor  $R_n$  (beginning at the currently selected rate and advancing the index,  $n$ , upward). The oscillator period ( $T_{ARS}$ ) is determined by  $C_{ARS}$ . When the VCO rate is at the input data rate, SER goes low and ceases to increment the counter.

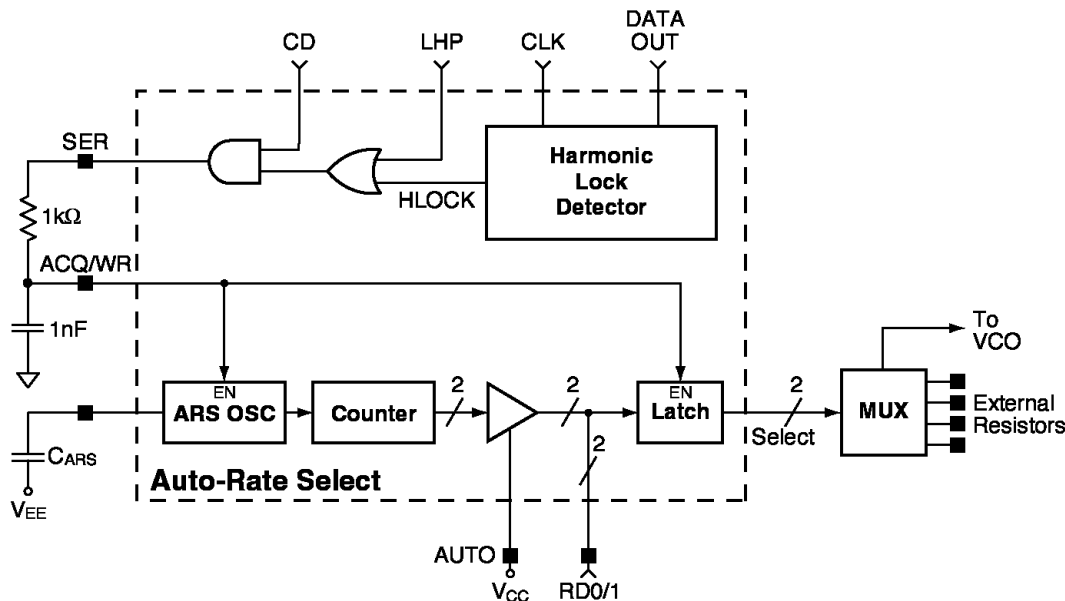

Figure 19. Auto-Rate Select

SER goes high when CD is high and either of the following conditions is true:

- The FD is active, causing LHP to go high.
- The harmonic lock detector determines that the VCO is running at a harmonic of the input data rate, causing HLOCK to go high.

Timing diagrams related to locking and unlocking of the PLL and removal of the input data are given in [Figure 20](#), [Figure 21](#) and [Figure 22](#). The term  $t_{ACQ}$  in [Figure 20](#) is defined in the [Loop Filter Design](#) section. Also,  $t_s$  is the settling time for the phase error to decay to less than 90°. It is given by the following equation:

$$t_s = R_{BW} \times C_z \times \ln(2) + 20 \mu s \quad (17)$$

The ARS oscillator period must be greater than the sum of  $t_{ACQ}$  and  $t_s$ :

$$t_{ARS} = (140 \text{ ms}/\mu F) \times C_{ARS} > t_{ACQ} + t_s \quad (18)$$

The harmonic lock detector senses if the VCO is locked to a data rate harmonic (integer multiple) by looking for the presence of bit changes across 3 consecutive periods of CLK as shown in Case 1 of [Figure 23](#). This event occurs on average 25% of the time in random data. HLOCK goes low if the occurrence rate is less than 12.5%. When a harmonic lock condition occurs there is at least a 2  $\mu s$  delay for HLOCK to go high. Case 2 illustrates the situation where CLK is at the 2nd harmonic of the input data rate and each input bit cell is double-clocked. Bit changes across three consecutive periods are never detected and HLOCK goes high.

During intervals of sparse data transitions, the harmonic lock detector may cause SER to go high. An example of this is the pathological pattern associated with the SMPTE 259M video industry standard. For an interval of 50  $\mu s$ , the input data transitions can be separated by 20-bit cells; and it appears to the harmonic lock detector as though the VCO is at a harmonic rate. So long as these intervals do not exceed the period of the ARS oscillator, the ARS sub-system will not increment the 2-bit counter.  $T_{ARS}$  **must be the greater of the value calculated by the above equation of the sparse data pattern interval.** [Figure 24](#) shows a timing diagram relating to sparse data transition intervals.

In auto-rate mode the user can monitor the RD0/1 bus to determine the automatically selected data rate. Refer to [Table 4](#) for the correspondence between the data bus state and the selected rate resistor.

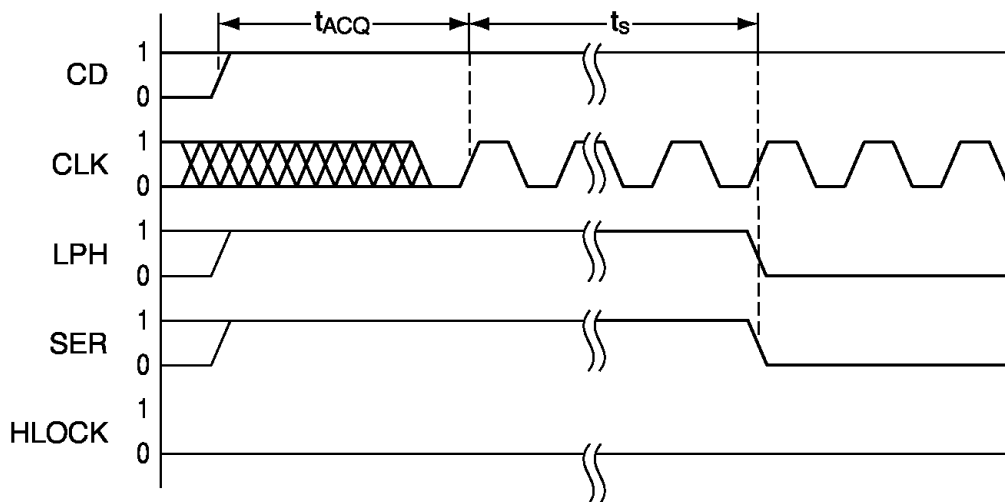

Figure 20. Data Rate Applied or Moves within PLL Capture

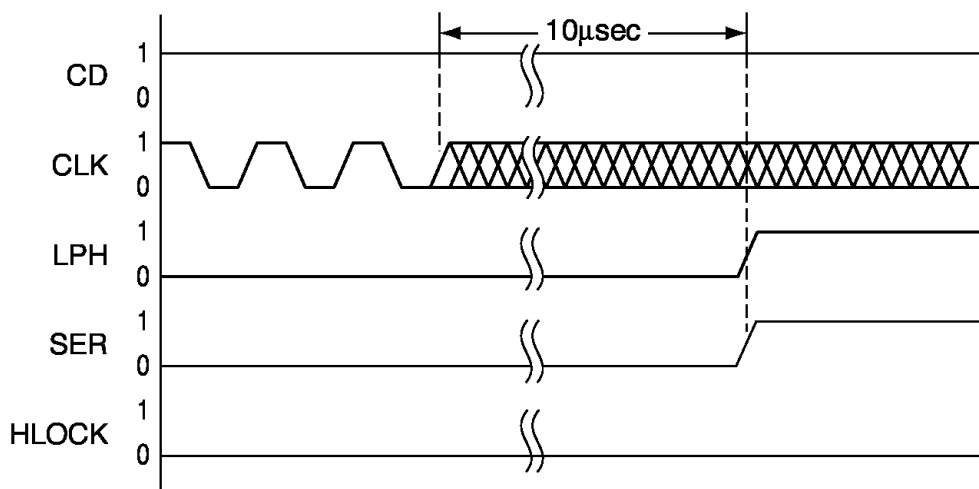

Figure 21. Data Rate Moves beyond the PLL Tracking Range

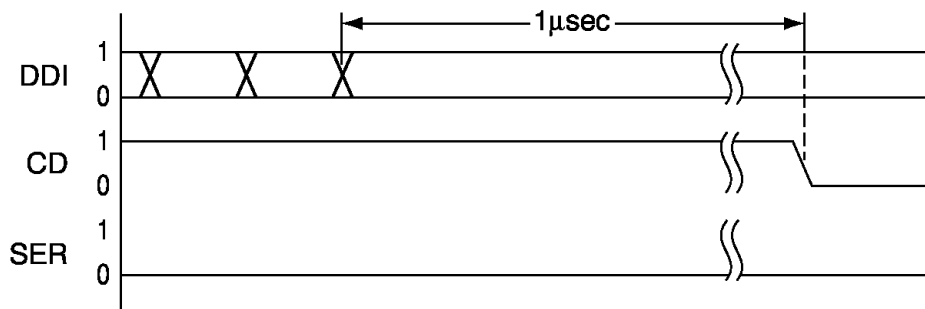

Figure 22. Input Data Removed

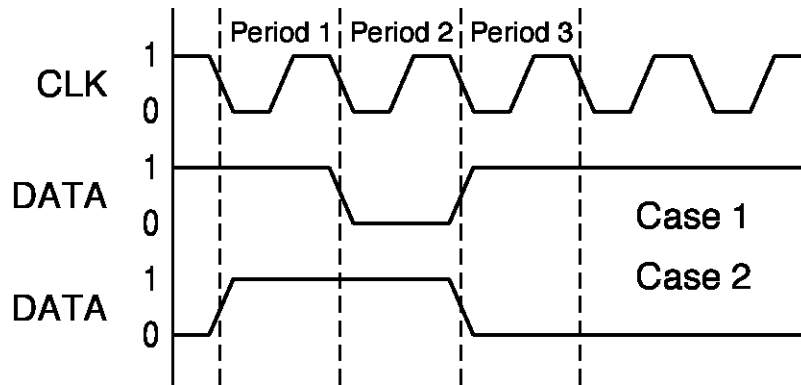

Figure 23. Harmonic Lock Detector Operation

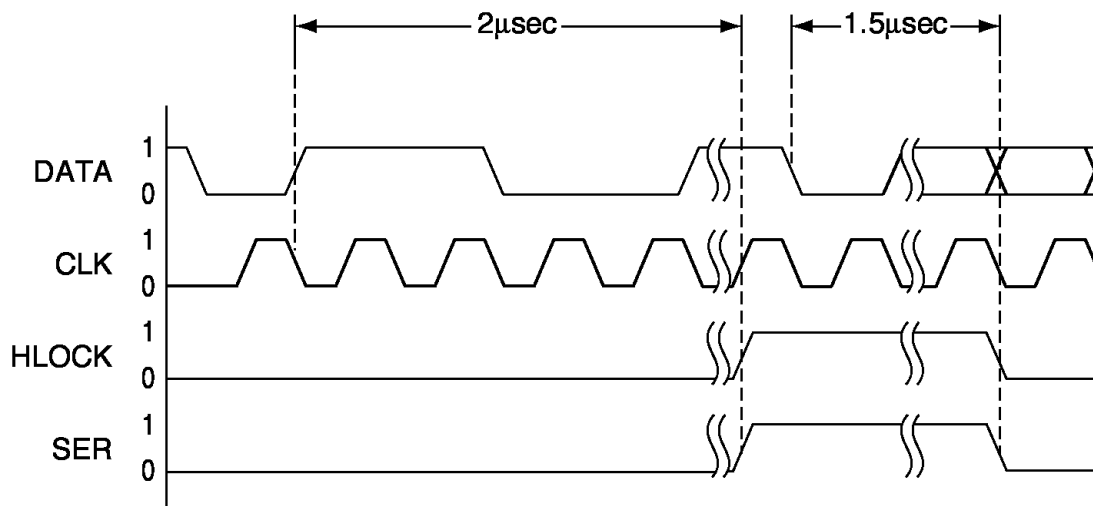

Figure 24. Response to Sparse Patterns

### Minimum Data Rate Spacing in ARM

RD0 and RD1 indicate which VCO rate configuration resistor (i.e.,  $R_n$ ) is selected. For each resistor there is a range of rates that the PLL will lock to. If two data rates fall within this range, a given RD0/RD1 indication may correspond to either rate. If it is desired that each incoming data rate be uniquely reported by RD0 and RD1, then the minimum spacing between data rates must be great enough to prevent the tracking and capture range of the PLL for one rate configuration resistor from encompassing the adjacent rate. The tracking and capture range is given in the [Electrical Characteristics](#) table. In addition, the tolerance of VCO rate configuration resistor should be added to the specified tracking and capture range in computing minimum data rate spacing.

### Manual Rate Mode (MRM)

The Manual Rate Mode provides the user with manual control over the data rate selection. This is done by setting the AUTO line low and shorting the  $C_{ARS}$  capacitor to  $V_{EE}$ . The manual data rate is set by the 2-bit bus RD0/1 using the ACQ/WR line to initiate a MUX update. Table 4 gives the state table for resistor selection.

Table 4. Rate State Table

ACQ/WR	RD1	RD0	Resistor
1	0	0	$R_0$
1	0	1	$R_1$
1	1	0	$R_2$
1	1	1	$R_3$
0	X	X	No Change

When in the MRM, the AUTO line is set low as in Figure 25. The buffer output is Tri-State which allows the bus lines RD0/1 to be used as inputs to the latch. The inputs RD0/1 are latched by using the ACQ/WR line.

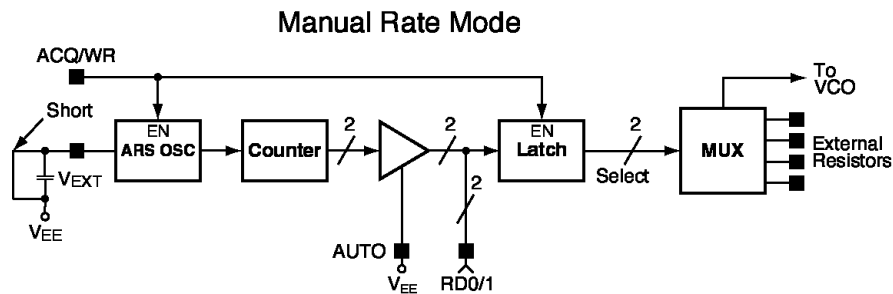

Figure 25. Manual Select Mode

The ACQ/WR line and bus lines RD0/1 must observe setup and hold conditions. The minimum requirements are specified in the sub-section Timing Performance of the Electrical Characteristics page. The timing diagram in Figure 26 indicates where the measurements are made.

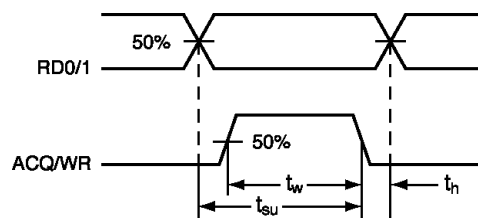

Figure 26. ACQ/WR and RD0/1 Timing Diagram

### Fixed Rate Mode

For single data rate applications, set AUTO low, ACQ/WR high, and tie RD0 and RD1 to the levels shown in Table 4. Also, short  $C_{ARS}$  to  $V_{EE}$ .

### Minimum Data Rate Spacing in MRM

If it is desired that SER goes high (due to the inability of the PLL rate) as an indication that the incoming data rate does not correspond to the intended rate selected by RD0 and RD1, then the minimum spacing between data rates must be great enough to prevent the tracking and capture range of the PLL at one rate from encompassing the adjacent rate. If the data rates are too close, it is possible for the PLL to lock to either rate regardless of which was selected by RD0 and RD1. The tracking and capture range is given in the [Electrical Characteristics](#) table. In addition, the tolerance of VCO rate configuration resistors should be added to the specified tracking and capture range in computing minimum data rate spacing.

### Output Timing

The clock-to-output data timing has a small delay of clock-to-data. This delay is specified in the [Electrical Characteristics](#) page under the sub-section [Timing Performance](#). The delay is measured from the 50% level of the CLK to the eye pattern 50% crossing, as shown in [Figure 27](#)

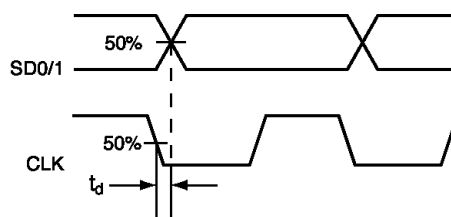

Figure 27. Output Timing of Clock and Data

## INPUT INTERFACES

The CLC016 provides high impedance inputs which accept differential or single-ended input drive. The detailed electrical specifications are found in the [Electrical Characteristics](#) page. Recommended interfaces for the CLC016 follow.

Four conditions should be observed when interfacing to the CLC016 inputs:

- Keep input levels within specified common-mode input range.
- Provide a bias current path to the inputs.
- Terminate cable in the proper impedance.
- Observe the output current requirements of the driving device.

[Figure 28](#) and [Figure 29](#) show DC and AC coupled interface examples which meet these four conditions.

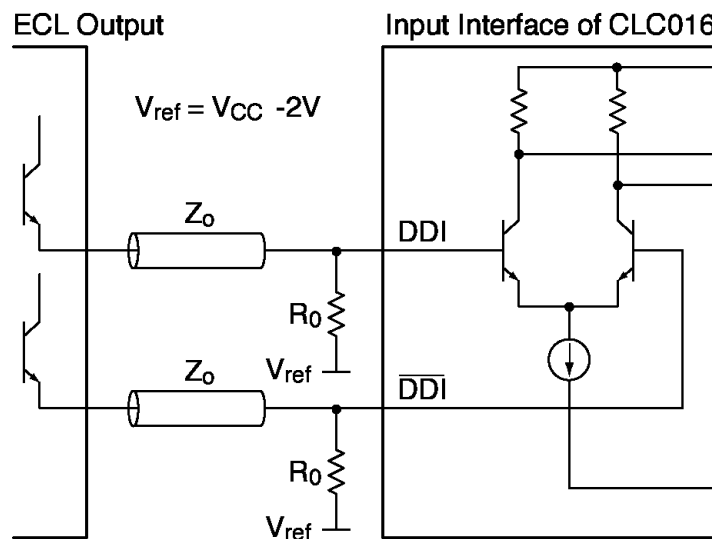

Figure 28. Differential 75Ω Source

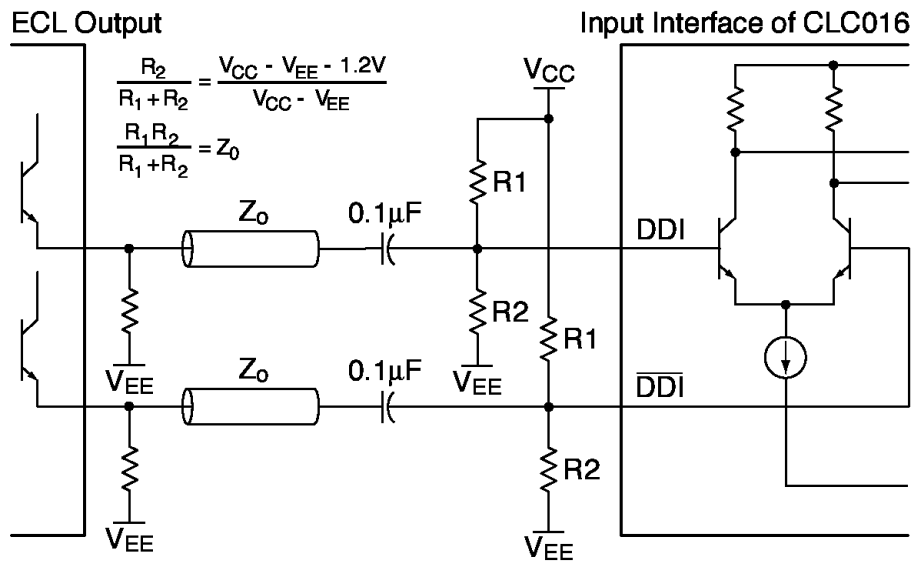

Figure 29. AC Coupled Termination

## OUTPUT INTERFACES

SDO,  $\overline{\text{SDO}}$ , SCO, and  $\overline{\text{SCO}}$  swing at ECL logic levels when the correct external components are used. However, the outputs are not standard emitter-coupled logic outputs. Instead, the signals flow from the collectors of the output transistors. The primary advantage of this architecture is lower power dissipation. Some example interfaces follow.

### Differential Load-Terminated Output Interface

Figure 30 shows an interface to drive signals differentially over a coaxial cable. The diode establishes  $V_{OH}$ . The diode-resistor network sets  $V_{OL}$ . The resistors terminate the cable in its characteristic impedance.

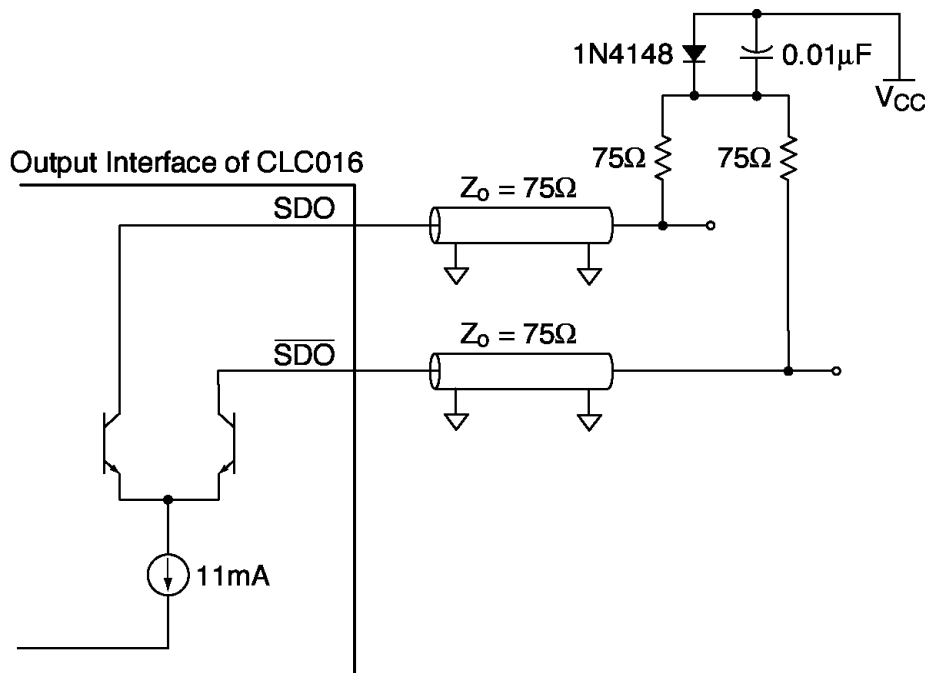

Figure 30. Differential Load-Terminated Output Interface

### Differential Source-Terminated Output Interface

Figure 31 is similar to Figure 30 except that the termination is placed near the output pins.

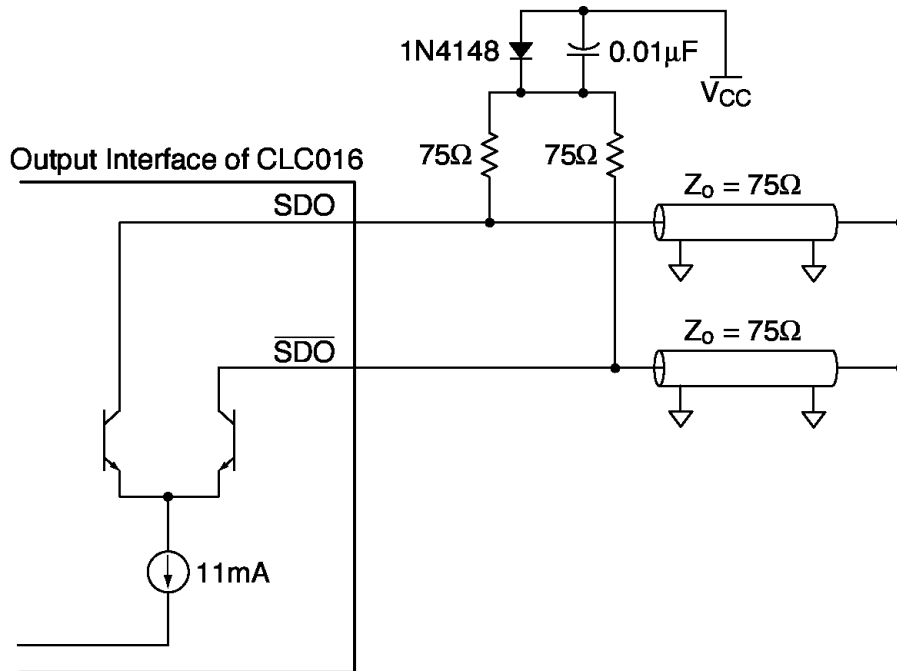

Figure 31. Differential Source-Terminated Output Interface

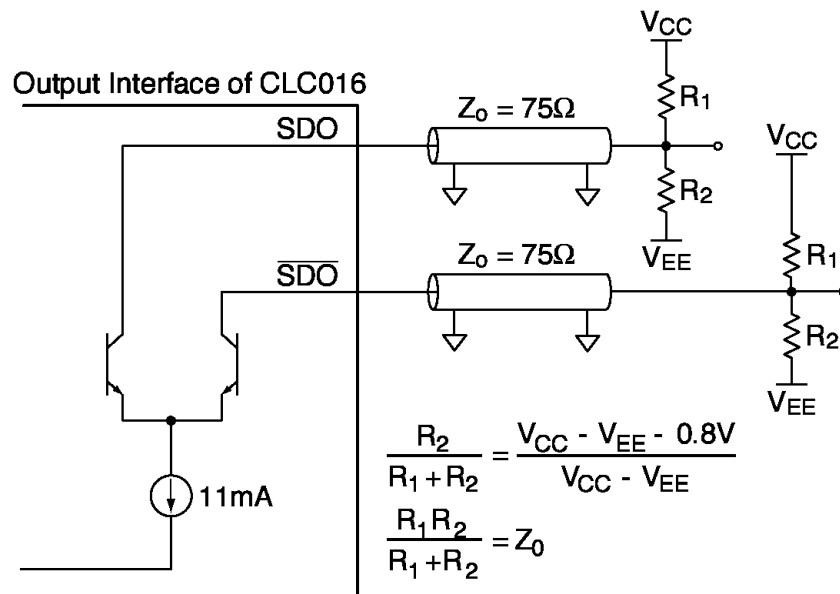

Figure 32. Load Terminated Output Interface

### Terminating Physically Separated Outputs

When the circuit design requires the outputs to be routed to separate locations, the recommended interface is depicted in Figure 32. Choose the resistors for an equivalent 75Ω termination of the cable impedance (or other cable characteristic impedance, as appropriate).



## CONTROL LINE INTERFACES

The use of the CLC016 with +5V supplies allows the control lines to interface to standard TTL logic signals. Operating the CLC016 at -5.2V requires level-shifting circuits for the control line inputs. Refer to the [Static Performance](#) section of the [Electrical Characteristics](#) table for required input voltage levels.

## POWER CONSUMPTION

The power supply current given in the [Electrical Characteristics](#) table includes the current required for both the clock and data output buffers to drive a 75Ω load to ECL swings.

## TYPICAL APPLICATIONS

The CLC016 was designed as one of a series of data transmission support chips. The CLC016 is recommended for a wide variety of clock and data recovery applications that fit within its range of data rates.

### Serial Data Transmission over Cable

Serial data transmission is common for all types of communication channels where the data is sent over coaxial or twisted pair cable. [Figure 33](#) shows a typical connection using a CLC006 driver chip, CLC014 Adaptive Cable Equalizer, and the CLC016 Data Retiming PLL. The CLC016 extracts the clock and retimes the data from the serial bit stream.

The components recommended in [Figure 33](#) support the four common data rates specified in SMPTE 259M.

## ESD

The CLC016 is a **CMOS chip**. Operators are cautioned to **use grounding straps when handling**.

## MEASUREMENTS & EVALUATION

When evaluating the CLC016 Data Retimer, it is recommended that you solder the part to the board or use a leadless chip carrier socket. Probing with capacitive probes will disturb the CLC016 performance. When probing the signal levels use a **1 pF capacitance** probe with a 500Ω tip.

The block diagram below shows a simple method of measuring the clock to eye pattern jitter. Use of the CLC016 evaluation board is recommended for jitter evaluation. It also provides a good reference for a user's circuit board design. The plot in [Figure 35](#) shows a histogram of the jitter and where the measurements were taken.

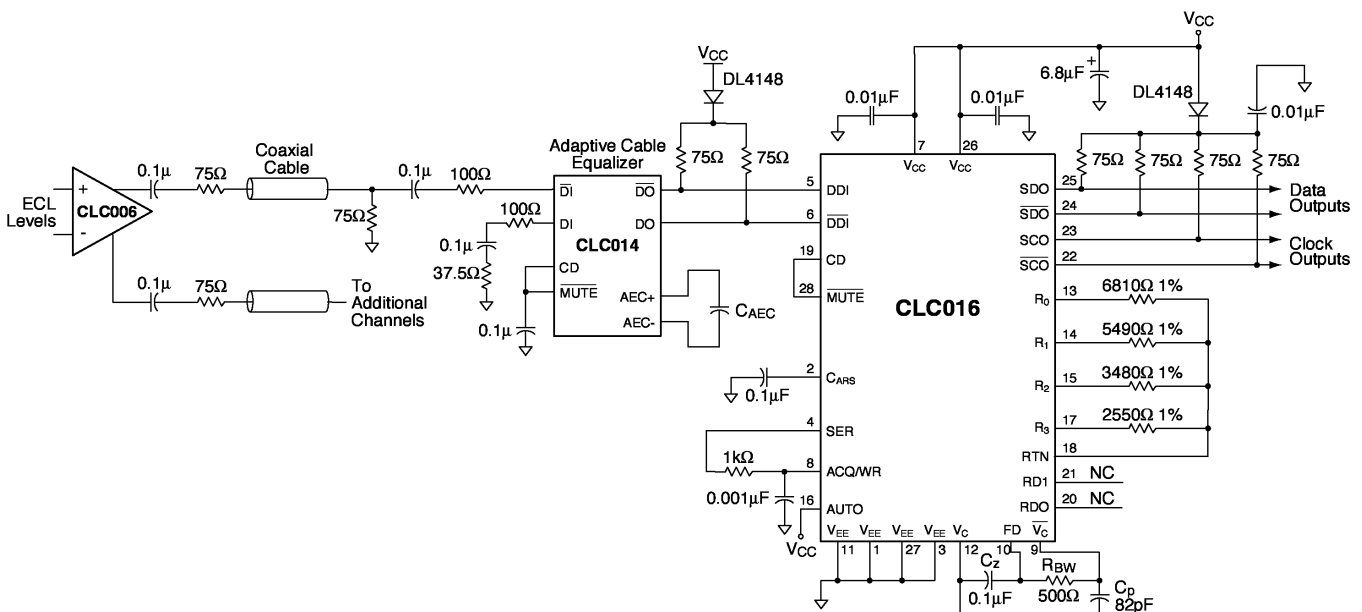

Figure 33. Typical Cable Connection - PLCC Package shown

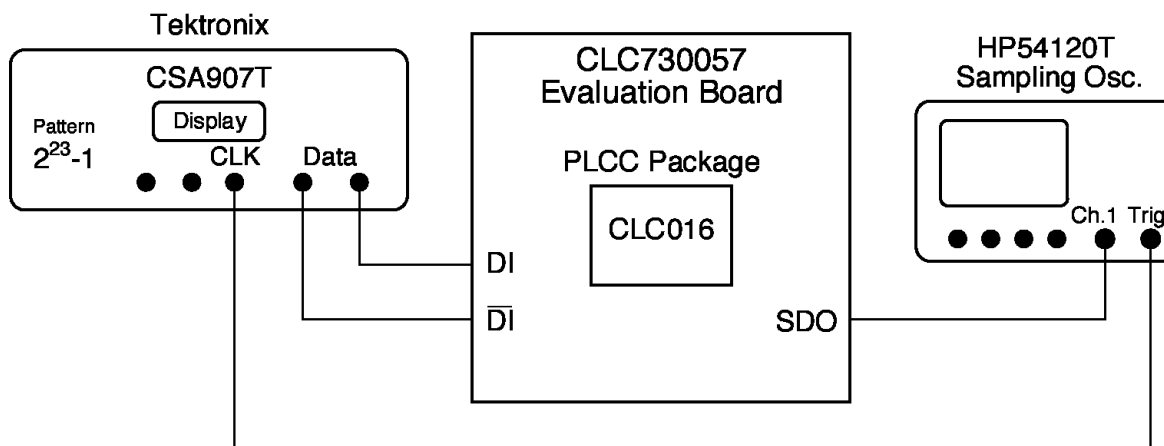

Figure 34. Jitter Measurement Setup

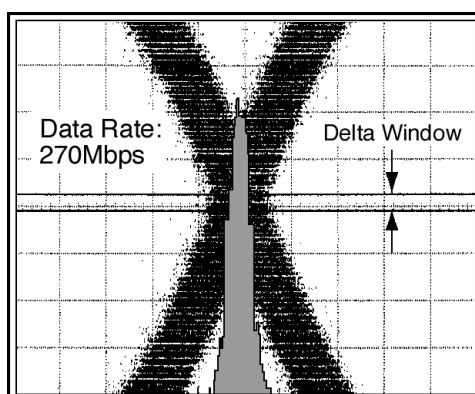

Figure 35. Typical Jitter Histogram

## PCB LAYOUT RECOMMENDATIONS

Printed circuit board layout affects the performance of the CLC016. The following are PCB layout rules for the CLC016:

1. Use a ground plane.
2. De-couple  $V_{CC}/V_{EE}$  power pins with 0.01  $\mu\text{F}$  ceramic capacitors placed  $\leq 0.1$ " (3mm) from the power pins and 6.8  $\mu\text{F}$  tantalum capacitors.
3. For long signal runs, match transmission lines to the desired characteristic impedance for the input and output lines.
4. Remove ground plane 0.025" (0.06mm) from all pads.
5. Remove ground plane from the area around the loop filter and frequency selection resistors.
6. Keep digital and analog lines sufficiently away from loop filter or frequency selection resistors.
7. Avoid the use of sockets in production boards.
8. In proto-boards use a low-profile, low impedance, type socket.

## EVALUATION BOARD

Evaluation boards are available for a nominal charge that demonstrate the basic operation of the SDI/SDV/SDH devices. The evaluation boards can be ordered through TI's Distributors. Supplies are limited, please check for current availability.

The SD901EVK SMPTE 259M Receiver evaluation kit provides an operating environment in which the data retimer can be evaluated by system / hardware designers. The evaluation board has all the needed circuitry and connectors for easy connection and checkout of the device circuit options as discussed in the CLC016 datasheet. A schematic, parts list and pictorial drawing are provided with the board.

- [Device Datasheet and / or EVK User Manual](#)
- [View a picture of the EVK](#)
- [View the EVK Schematic](#)
- [View the top assembly drawing and BOM](#)
- [View the bottom assembly drawing and BOM](#)

## IMPORTANT NOTICE

Texas Instruments Incorporated and its subsidiaries (TI) reserve the right to make corrections, enhancements, improvements and other changes to its semiconductor products and services per JESD46, latest issue, and to discontinue any product or service per JESD48, latest issue. Buyers should obtain the latest relevant information before placing orders and should verify that such information is current and complete. All semiconductor products (also referred to herein as "components") are sold subject to TI's terms and conditions of sale supplied at the time of order acknowledgment.

TI warrants performance of its components to the specifications applicable at the time of sale, in accordance with the warranty in TI's terms and conditions of sale of semiconductor products. Testing and other quality control techniques are used to the extent TI deems necessary to support this warranty. Except where mandated by applicable law, testing of all parameters of each component is not necessarily performed.

TI assumes no liability for applications assistance or the design of Buyers' products. Buyers are responsible for their products and applications using TI components. To minimize the risks associated with Buyers' products and applications, Buyers should provide adequate design and operating safeguards.

TI does not warrant or represent that any license, either express or implied, is granted under any patent right, copyright, mask work right, or other intellectual property right relating to any combination, machine, or process in which TI components or services are used. Information published by TI regarding third-party products or services does not constitute a license to use such products or services or a warranty or endorsement thereof. Use of such information may require a license from a third party under the patents or other intellectual property of the third party, or a license from TI under the patents or other intellectual property of TI.

Reproduction of significant portions of TI information in TI data books or data sheets is permissible only if reproduction is without alteration and is accompanied by all associated warranties, conditions, limitations, and notices. TI is not responsible or liable for such altered documentation. Information of third parties may be subject to additional restrictions.

Resale of TI components or services with statements different from or beyond the parameters stated by TI for that component or service voids all express and any implied warranties for the associated TI component or service and is an unfair and deceptive business practice. TI is not responsible or liable for any such statements.

Buyer acknowledges and agrees that it is solely responsible for compliance with all legal, regulatory and safety-related requirements concerning its products, and any use of TI components in its applications, notwithstanding any applications-related information or support that may be provided by TI. Buyer represents and agrees that it has all the necessary expertise to create and implement safeguards which anticipate dangerous consequences of failures, monitor failures and their consequences, lessen the likelihood of failures that might cause harm and take appropriate remedial actions. Buyer will fully indemnify TI and its representatives against any damages arising out of the use of any TI components in safety-critical applications.

In some cases, TI components may be promoted specifically to facilitate safety-related applications. With such components, TI's goal is to help enable customers to design and create their own end-product solutions that meet applicable functional safety standards and requirements. Nonetheless, such components are subject to these terms.

No TI components are authorized for use in FDA Class III (or similar life-critical medical equipment) unless authorized officers of the parties have executed a special agreement specifically governing such use.

Only those TI components which TI has specifically designated as military grade or "enhanced plastic" are designed and intended for use in military/aerospace applications or environments. Buyer acknowledges and agrees that any military or aerospace use of TI components which have **not** been so designated is solely at the Buyer's risk, and that Buyer is solely responsible for compliance with all legal and regulatory requirements in connection with such use.

TI has specifically designated certain components as meeting ISO/TS16949 requirements, mainly for automotive use. In any case of use of non-designated products, TI will not be responsible for any failure to meet ISO/TS16949.

### Products

Audio	<a href="http://www.ti.com/audio">www.ti.com/audio</a>
Amplifiers	<a href="http://amplifier.ti.com">amplifier.ti.com</a>
Data Converters	<a href="http://dataconverter.ti.com">dataconverter.ti.com</a>
DLP® Products	<a href="http://www.dlp.com">www.dlp.com</a>
DSP	<a href="http://dsp.ti.com">dsp.ti.com</a>
Clocks and Timers	<a href="http://www.ti.com/clocks">www.ti.com/clocks</a>
Interface	<a href="http://interface.ti.com">interface.ti.com</a>
Logic	<a href="http://logic.ti.com">logic.ti.com</a>
Power Mgmt	<a href="http://power.ti.com">power.ti.com</a>
Microcontrollers	<a href="http://microcontroller.ti.com">microcontroller.ti.com</a>
RFID	<a href="http://www.ti-rfid.com">www.ti-rfid.com</a>
OMAP Applications Processors	<a href="http://www.ti.com/omap">www.ti.com/omap</a>
Wireless Connectivity	<a href="http://www.ti.com/wirelessconnectivity">www.ti.com/wirelessconnectivity</a>

### Applications

Automotive and Transportation	<a href="http://www.ti.com/automotive">www.ti.com/automotive</a>
Communications and Telecom	<a href="http://www.ti.com/communications">www.ti.com/communications</a>
Computers and Peripherals	<a href="http://www.ti.com/computers">www.ti.com/computers</a>
Consumer Electronics	<a href="http://www.ti.com/consumer-apps">www.ti.com/consumer-apps</a>
Energy and Lighting	<a href="http://www.ti.com/energy">www.ti.com/energy</a>
Industrial	<a href="http://www.ti.com/industrial">www.ti.com/industrial</a>
Medical	<a href="http://www.ti.com/medical">www.ti.com/medical</a>
Security	<a href="http://www.ti.com/security">www.ti.com/security</a>
Space, Avionics and Defense	<a href="http://www.ti.com/space-avionics-defense">www.ti.com/space-avionics-defense</a>
Video and Imaging	<a href="http://www.ti.com/video">www.ti.com/video</a>

### TI E2E Community

[e2e.ti.com](http://e2e.ti.com)