

FOR TABLE ONE SEE
 PG. 285

**STANDARD MICROSYSTEMS
 CORPORATION**

390-835

**COM 8116
 COM 8116T
 COM 8136
 COM 8136T**

Dual Baud Rate Generator Programmable Divider

FEATURES

- On chip crystal oscillator or external frequency input
- Single +5v power supply
- Choice of 2 x 16 output frequencies
- 16 asynchronous/synchronous baud rates
- Direct UART/USRT/ASTRO/USYNRT compatibility
- Full duplex communication capability
- High frequency reference output*
- Re-programmable ROM via CLASP® technology allows generation of other frequencies
- TTL, MOS compatibility
- Compatible with COM 5016/COM 5036

PIN CONFIGURATION

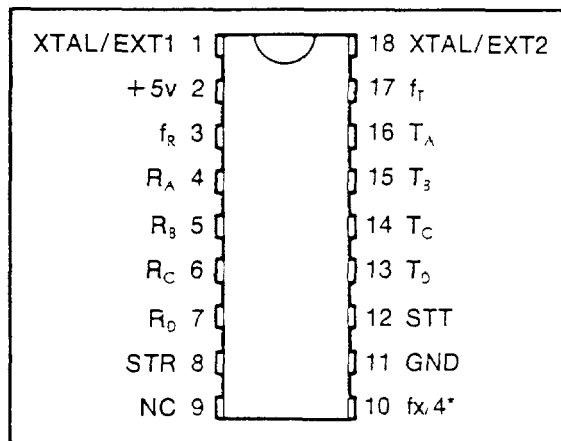

BLOCK DIAGRAM

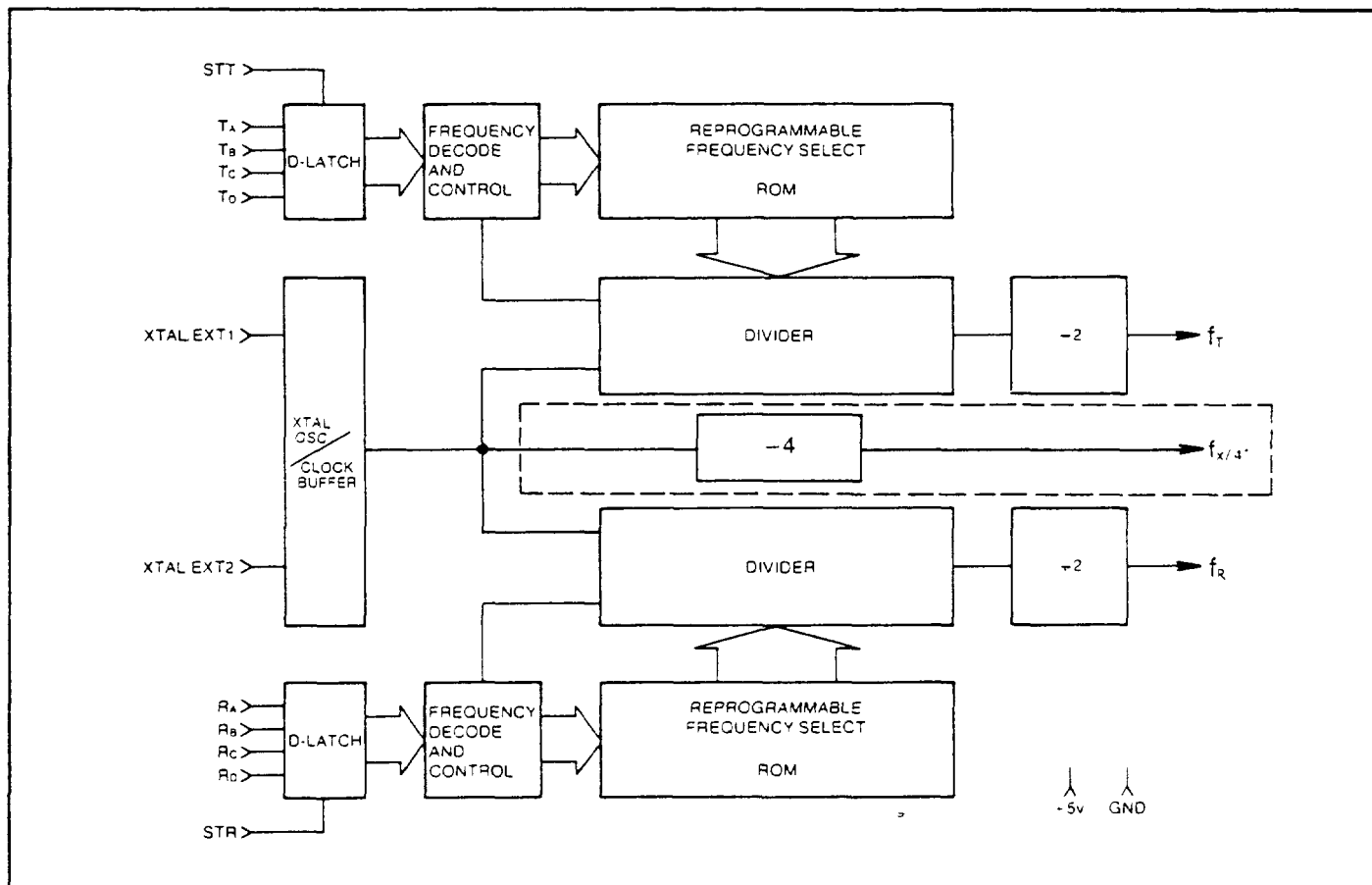

*COM 8136/T only

General Description

The Standard Microsystem's COM 8116/COM 8136 is an enhanced version of the COM 5016/COM 5036 Dual Baud Rate Generator. It is fabricated using SMC's patented COPLAMOS® and CLASP® technologies and employs depletion mode loads, allowing operation from a single +5v supply

The standard COM 8116/COM 8136 is specifically dedicated to generating the full spectrum of 16 asynchronous/synchronous data communication frequencies for 16X UART/USRT devices. A large number of the frequencies available are also useful for 1X and 32X ASTRO/USYNRT devices

The COM 8116/COM 8136 features an internal crystal oscillator which may be used to provide the master reference frequency. Alternatively, an external reference may be supplied by applying complementary TTL level signals to pins 1 and 18. Parts suitable for use only with an external TTL reference are marked COM 8116T/COM 8136T. TTL outputs used to drive the COM 8116/COM 8136 or COM 8116T/COM 8136T XTAL/EXT inputs should not be used to drive

other TTL inputs, as noise immunity may be compromised due to excessive loading.

The output of the oscillator/buffer is applied to the dividers for generation of the output frequencies f_r , f_a . The dividers are capable of dividing by any integer from 6 to $2^{19} - 1$, inclusive. If the divisor is even, the output will be square; otherwise the output will be high longer than it is low by one f_x clock period.

The reference frequency (f_x) is used to provide a high frequency output at $f_x/4$ on the COM 8136/T.

Each of the two divisor ROMs contains 16 divisors, each 19 bits wide, and is fabricated using SMC's unique CLASP® technology allowing up to 32 different divisors on custom parts. This process permits reduction of turn-around time for ROM patterns. Each group of four divisor select bits is held in an externally strobed data latch. The strobe input is level sensitive: while the strobe is high, data is passed directly through to the ROM. Initiation of a new frequency is effected within 3 μ s of a change in any of the four divisor select bits (strobe activity is not required). The divisor select inputs have pull-up resistors, the strobe inputs do not.

Description of Pin Functions

Pin No.	Symbol	Name	Function
1	XTAL/EXT1	Crystal or External Input 1	This input is either one pin of the crystal package or one polarity of the external input.
2	V_{CC}	Power Supply	+5 volt supply
3	f_r	Receiver Output Frequency	This output runs at a frequency selected by the Receiver divisor select data bits.
4-7	R_A, R_3, R_C, R_D	Receiver-Divisor Select Data Bits	The logic level on these inputs, as shown in Table 1, selects the receiver output frequency, f_r .
8	STR	Strobe-Receiver	A high level input strobe loads the receiver data (R_A, R_3, R_C, R_D) into the receiver divisor select register. This input may be strobed or hard-wired to a high level.
9	NC	No Connection	
10	$f_x/4^*$	$f_x/4$	$1/4$ crystal/clock frequency reference output.
11	GND	Ground	Ground
12	STT	Strobe-Transmitter	A high level input strobe loads the transmitter data (T_A, T_3, T_C, T_D) into the transmitter divisor select register. This input may be strobed or hard-wired to a high level.
13-16	T_C, T_C, T_3, T_A	Transmitter-Divisor Select Data Bits	The logic level on these inputs, as shown in Table 1, selects the transmitter output frequency, f_r .
17	f_r	Transmitter Output Frequency	This output runs at a frequency selected by the Transmitter divisor select data bits.
18	XTAL/EXT2	Crystal or External Input 2	This input is either the other pin of the crystal package or the other polarity of the external input

*COM 8136/T only

For electrical characteristics, see page 281

ELECTRICAL CHARACTERISTICS COM8046, COM8046T, COM8116, COM8116T, COM8126, COM8126T, COM8136, COM8136T, COM8146, COM8146T

MAXIMUM GUARANTEED RATINGS

Operating Temperature Range	0°C to + 70°C
Storage Temperature Range	-55°C to +150°C
Lead Temperature (soldering, 10 sec)	+325°C
Positive Voltage on any Pin with respect to ground	+8.0V
Negative Voltage on any Pin with respect to ground	-0.3V

Stresses above those listed may cause permanent damage to the device. This is a stress rating only and functional operation of the device at these or at any other condition above those indicated in the operational sections of this specification is not implied.

NOTE: When powering this device from laboratory or system power supplies, it is important that the Absolute Maximum Ratings not be exceeded or device failure can result. Some power supplies exhibit voltage spikes or "glitches" on their outputs when the AC power is switched on and off. In addition, voltage transients on the AC power line may appear on the DC output. If this possibility exists it is suggested that a clamp circuit be used.

ELECTRICAL CHARACTERISTICS (T_A=0°C to 70°C, V_{CC}=+5V±5% unless otherwise noted)

Parameter	Min.	Typ.	Max.	Unit	Comments
D.C. CHARACTERISTICS					
INPUT VOLTAGE LEVELS					
Low-level, V _{IL}	2.0		0.8	V	excluding XTAL inputs
High-level, V _{IH}				V	
OUTPUT VOLTAGE LEVELS					
Low-level, V _{OL}			0.4	V	I _{OL} = 1.6mA, for f _X /4, f _O /16
			0.4	V	I _{OL} = 3.2mA, for f _O , f _R , f-
			0.4	V	I _{OL} = 0.8mA, for f _X
High-level, V _{OH}	3.5			V	I _{OH} = -100µA; for f _X , I _{OH} = -50µA
INPUT CURRENT					
Low-level, I _L			-0.1	mA	V _{IH} = GND, excluding XTAL inputs
INPUT CAPACITANCE					
All inputs, C _{IN}		5	10	pF	V _{IH} = GND, excluding XTAL inputs
EXT INPUT LOAD					
		8	10		Series 7400 equivalent loads
POWER SUPPLY CURRENT					
I _{CC}			50	mA	
A.C. CHARACTERISTICS					
T _A = +25°C					
CLOCK FREQUENCY, f_{CLK}					
	0.01		7.0	MHz	XTAL/EXT, 50% Duty Cycle ±5%
	0.01		5.1	MHz	COM 8046, COM 8126, COM 8146
					XTAL/EXT, 50% Duty Cycle ±5%
					COM 8116, COM 8136
STROBE PULSE WIDTH, t_{pw}					
	150		DC	ns	
INPUT SET-UP TIME					
t _{es}	200			ns	
INPUT HOLD TIME					
t _{oh}	50			ns	
STROBE TO NEW FREQUENCY DELAY					
			3.5	µs	@ f _X = 5.0 MHz

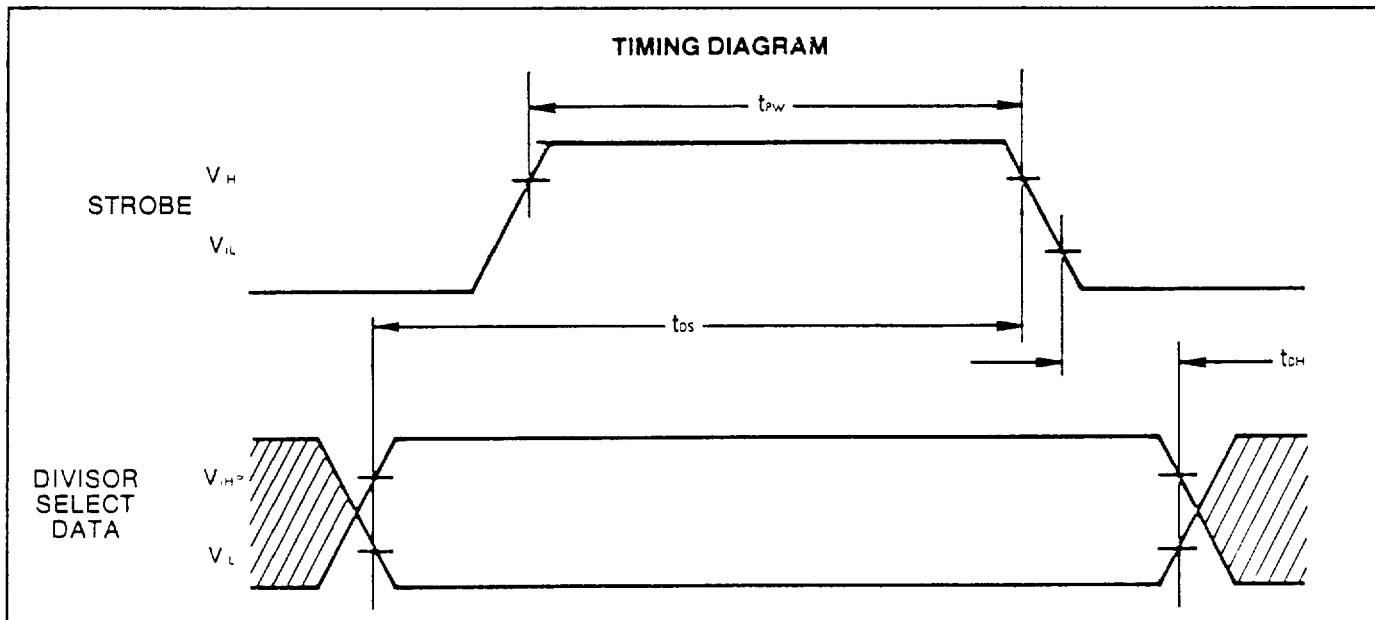

Baud Rate Generator Output Frequency Options

COM 8116T-013
CRYSTAL FREQUENCY = 2.76480 MHz

Transmit/Receive Address				Baud Rate	Theoretical Frequency 16X Clock	Actual Frequency 16X Clock	Percent Error	Duty Cycle %	Divisor
D	C	B	A						
0	0	0	0	50	0.8 KHz	0.8 KHz	0	50/50	3456
0	0	0	1	75	1.2	1.2	0	50/50	2304
0	0	1	0	110	1.76	1.76	-006	50/50	1571
0	0	1	1	134.5	2.152	2.152	-019	50/50	1285
0	1	0	0	150	2.4	2.4	0	50/50	1152
0	1	0	1	200	3.2	3.2	0	50/50	864
0	1	1	0	300	4.8	4.8	0	50/50	576
0	1	1	1	600	9.6	9.6	0	50/50	288
1	0	0	0	1200	19.2	19.2	0	50/50	144
1	0	0	1	1800	28.8	28.8	0	50/50	96
1	0	1	0	2000	32.0	32.149	+465	50/50	86
1	0	1	1	2400	38.4	38.4	0	50/50	72
1	1	0	0	3600	57.6	57.6	0	50/50	48
1	1	0	1	4800	76.8	76.8	0	50/50	36
1	1	1	0	9600	153.6	153.6	0	50/50	18
1	1	1	1	19,200	307.2	307.2	0	44.56	9

COM 8116T-003
CRYSTAL FREQUENCIES = 6.01835 MHz

Transmit/Receive Address				Baud Rate	Theoretical Frequency 16X Clock	Actual Frequency 16X Clock	Percent Error	Duty Cycle %	Divisor
D	C	B	A						
0	0	0	0	50	0.8 KHz	799.9 Hz	0	50/50	7523
0	0	0	1	75	1.2	1200.0	0	50/50	5015
0	0	1	0	110	1.76	1759.7	0	50/50	3420
0	0	1	1	134.5	2.152	2151.7	0	50/50	2797
0	1	0	0	150	2.4	2399.6	0	50/50	2508
0	1	0	1	200	3.2	3199.5	0	50/50	1881
0	1	1	0	300	4.8	4799.3	0	50/50	1254
0	1	1	1	600	9.6	9598.6	0	50/50	627
1	0	0	0	1200	19.2	19227.9	+0.14	50/50	313
1	0	0	1	1800	28.8	28795.9	0	50/50	209
1	0	1	0	2000	32.0	32012.5	0	50/50	188
1	0	1	1	2400	38.4	38333.4	-0.17	50/50	157
1	1	0	0	3600	57.6	57868.7	+0.46	50/50	104
1	1	0	1	4800	76.8	77158.3	+0.46	50/50	78
1	1	1	0	9600	153.6	154316.6	+0.46	50/50	39
1	1	1	1	19,200	307.2	300917.5	2.04	50/50	20

COM 8116T-013A
CRYSTAL FREQUENCY—5.52960 MHz

Transmit/Receive Address				Baud Rate	Theoretical Frequency 16X Clock	Actual Frequency 16X Clock	Percent Error	Duty Cycle %	Divisor
D	C	B	A						
0	0	0	0	100	1.6 KHz	1.6 KHz	0	50/50	3456
0	0	0	1	150	2.4	2.4	0	50/50	2304
0	0	1	0	220	3.52	3.5197	-006	50/50	1571
0	0	1	1	269	4.304	4.3032	-019	50/50	1285
0	1	0	0	300	4.8	4.8	0	50/50	1152
0	1	0	1	400	6.4	6.4	0	50/50	864
0	1	1	0	600	9.6	9.6	0	50/50	576
0	1	1	1	1200	19.2	19.2	0	50/50	288
1	0	0	0	2400	38.4	38.4	0	50/50	144
1	0	0	1	3600	57.6	57.6	0	50/50	96
1	0	1	0	4000	64.0	64.298	+466	50/50	86
1	0	1	1	4800	76.8	76.8	0	50/50	72
1	1	0	0	7200	115.2	115.2	0	50/50	48
1	1	0	1	9600	153.6	153.6	0	50/50	36
1	1	1	0	19,200	307.2	307.2	0	50/50	18
1	1	1	1	38,400	614.8	614.8	0	44.56	9