



CS4923/4/5/6/7/8/9

Multi-Channel Digital Audio Decoders

- CS4923/4/5/6/7/8 features
 - Optional Virtual 3D Output
 - Simulated Surround and Programmable Effects
 - Real Time Autodetection of Dolby Digital[®], DTS[®], MPEG Multi-Channel and PCM
 - Flexible 6-channel master or slave output
- CS4923/4/5/6/7/8/9 features
 - IEC60958/61937 transmitter for compressed-data or linear-PCM output
 - Dedicated 8 kilobyte input buffer
 - DAC clock via analog phase-locked loop
 - Dedicated byte wide or serial host interface
 - Multiple compressed data input modes
 - PES layer decode for A/V synchronization
 - 96-kHz-capable PCM I/O, master or slave
 - Optional external memory and auto-boot
 - +3.3-V CMOS low-power, 44-pin package
- CS4923/4/5/6 features
 - Capable of Dolby Digital[®] Group A Performance
 - Dolby bass manager and crossover filters
 - Dolby Surround Pro Logic[®] Decoding
- CS4925/7: MPEG-2 Multi-Channel Decoder
- CS4926/8: DTS Multi-Channel Decoder
- CS4929: AAC 2-Channel (Low Complexity) and MPEG-2 Stereo Decoder

Description

The CS4923/4/5/6/7/8 is a family of multi-channel digital audio decoders, with the exception of the CS4929 as the only stereo digital audio decoder. The CS4923/4/5/6 are designed for Dolby Digital and MPEG-2 Stereo decoding. In addition the CS4925 adds MPEG-2 multi-channel decoding capability and the CS4926 provides DTS decoding. The CS4927 is an MPEG-2 multi-channel decoder and the CS4928 is a DTS multi-channel decoder. The CS4929 is an AAC 2-channel and MPEG-2 stereo decoder. Each one of the CS4923/4/5/6/7/8/9 provides a complete and flexible solution for multi-channel (or stereo in the case of the CS4929) audio decoding in home A/V receiver/amplifiers, DVD movie players, out-board decoders, laser-disc players, HDTV sets, head-end decoders, set-top boxes, and similar products.

Cirrus Logic's Crystal Audio Division provides a complete set of audio decoder and auxiliary audio DSP application programs for various applications. For all complementary analog and digital audio I/O, Crystal Audio also provides a complete set of high-quality audio peripherals including: multimedia CODECs, stereo A/D and D/A converters and IEC60958 interfaces. Of special note, the CS4226 is a complementary CODEC providing a digital receiver, stereo A/D converters, and six 20-bit DACs in one package.

ORDERING INFORMATION

- CS4923xx-CL 44-pin PLCC (xx = ROM revision)
- CRD4923 Reference design with CS4226
- CDB4923 Evaluation board

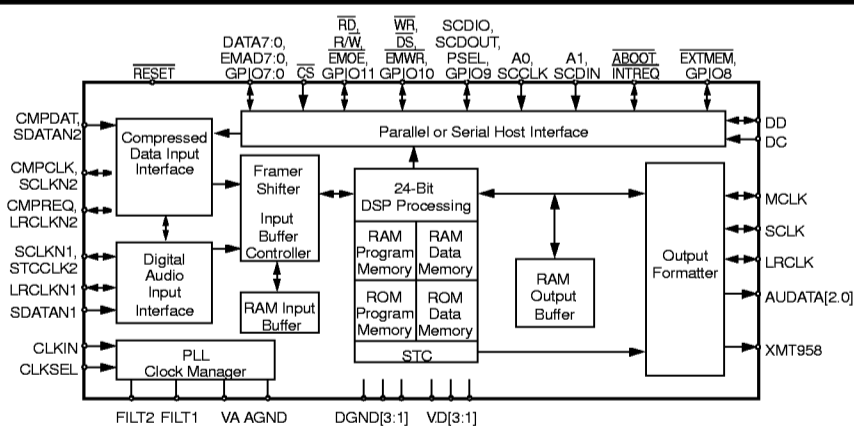

Preliminary Product Information

This document contains information for a new product. Cirrus Logic reserves the right to modify this product without notice.

CIRRUS LOGIC
 P.O. Box 17847, Austin, Texas 78760
 (512) 445 7222 FAX: (512) 445 7581
<http://www.cirrus.com>

Copyright © Cirrus Logic, Inc. 1999
 (All Rights Reserved)

AUG '99
DS262F2
1



TABLE OF CONTENTS

1. CHARACTERISTICS AND SPECIFICATIONS	4
ABSOLUTE MAXIMUM RATINGS	4
RECOMMENDED OPERATING CONDITIONS	4
DIGITAL D.C. CHARACTERISTICS	4
POWER SUPPLY CHARACTERISTICS	4
SWITCHING CHARACTERISTICS—RESET	5
SWITCHING CHARACTERISTICS—CMPDAT, CMPCLK	6
SWITCHING CHARACTERISTICS—CLKIN	7
SWITCHING CHARACTERISTICS—INTEL® HOST MODE	8
SWITCHING CHARACTERISTICS—MOTOROLA® HOST MODE	10
SWITCHING CHARACTERISTICS—DIGITAL AUDIO INPUT	16
SWITCHING CHARACTERISTICS—DIGITAL AUDIO OUTPUT	18
2. FAMILY OVERVIEW	20
2.1 Multi-channel Decoder Family of Parts	21
2.2 Document Strategy	21
2.2.1 Hardware Documentation	22
2.2.2 CS4923/4/5/6/7/8/9 Application Code User's Guides	22
2.3 Using the CS4923/4/5/6/7/8/9	22
3. TYPICAL CONNECTION DIAGRAMS	23
3.1 Multiplexed Pins	23
3.2 Termination Requirements	24
3.3 Phase Locked Loop Filter	24
4. POWER	31
4.1 Decoupling	31
4.2 Analog Power Conditioning	31
4.3 Pads	31
5. CLOCKING	32
6. CONTROL	33
6.1 Boot and Control Mode Overview	33
6.2 Parallel Host Interface	34
6.2.1 Intel Parallel Host Mode	34
6.2.2 Motorola Parallel Host Mode	36
6.3 SPI Serial Host Interface	36
6.3.1 SPI Write	37
6.3.2 SPI Read	37

Contacting Cirrus Logic Support

For a complete listing of Direct Sales, Distributor, and Sales Representative contacts, visit the Cirrus Logic web site at:
<http://www.cirrus.com/corporate/contacts/>

Dolby, Dolby Digital, and Pro Logic are registered trademarks of Dolby Laboratories Licensing Corporation.

Intel is a registered trademark of Intel Corporation.

Motorola is a registered trademark of Motorola, Inc.

PC is a registered trademark of Philips Semiconductor.

All other names are trademarks, registered trademarks, or service marks of their respective companies.

Preliminary product information describes products which are in production, but for which full characterization data is not yet available. Advance product information describes products which are in development and subject to development changes. Cirrus Logic, Inc. has made best efforts to ensure that the information contained in this document is accurate and reliable. However, the information is subject to change without notice and is provided "AS IS" without warranty of any kind (express or implied). No responsibility is assumed by Cirrus Logic, Inc. for the use of this information, nor for infringements of patents or other rights of third parties. This document is the property of Cirrus Logic, Inc. and implies no license under patents, copyrights, trademarks, or trade secrets. No part of this publication may be copied, reproduced, stored in a retrieval system, or transmitted, in any form or by any means (electronic, mechanical, photographic, or otherwise) without the prior written consent of Cirrus Logic, Inc. Items from any Cirrus Logic website or disk may be printed for use by the user. However, no part of the printout or electronic files may be copied, reproduced, stored in a retrieval system, or transmitted, in any form or by any means (electronic, mechanical, photographic, or otherwise) without the prior written consent of Cirrus Logic, Inc. Furthermore, no part of this publication may be used as a basis for manufacture or sale of any items without the prior written consent of Cirrus Logic, Inc. The names of products of Cirrus Logic, Inc. or other vendors and suppliers appearing in this document may be trademarks or service marks of their respective owners which may be registered in some jurisdictions. A list of Cirrus Logic, Inc. trademarks and service marks can be found at <http://www.cirrus.com>.

6.4 I ² C Serial Host Interface	39
6.4.1 I ² C Write	39
6.4.2 I ² C Read	39
6.5 External Memory	41
6.5.1 External Memory and Autboot	43
7. DIGITAL INPUT & OUTPUT	44
7.1 Digital Audio Formats	44
7.2 Digital Audio Input Port	46
7.3 Compressed Data Input Port	46
7.4 Parallel Digital Audio Data Input	46
7.5 Digital Audio Output Port	47
7.5.1 IEC60958 Output	48
8. PIN DESCRIPTIONS	49
9. PACKAGE DIMENSIONS	54

LIST OF FIGURES

Figure 1. RESET Timing	5
Figure 2. Serial Compressed Data Timing	6
Figure 3. CLKIN with CLKSEL = VSS = PLL Enable.....	7
Figure 4. CLKIN with CLKSEL = VD = PLL Bypass	7
Figure 5. Intel Parallel Host Mode Read Cycle.....	9
Figure 6. Intel Parallel Host Mode Write Cycle.....	9
Figure 7. Motorola Parallel Host Mode Read Cycle	11
Figure 8. Motorola Parallel Host Mode Write Cycle.....	11
Figure 9. SPI Control Port Timing.....	13
Figure 10. I ² C Control Port Timing	15
Figure 11. Digital Audio Input, Data and Clock Timing.....	17
Figure 12. Digital Audio Output, Data and Clock Timing.....	19
Figure 13. I ² C Control.....	25
Figure 14. I ² C Control with External Memory	26
Figure 15. SPI Control.....	27
Figure 16. SPI Control with External Memory	28
Figure 17. Intel Parallel Control Mode	29
Figure 18. Motorola Parallel Control Mode.....	30
Figure 19. SPI Timing	38
Figure 20. I ² C Timing	40
Figure 21. External Memory Interface	42
Figure 22. Run-Time Memory Access	42
Figure 23. Autboot Timing Diagram.....	43
Figure 24. I ² S Format	45
Figure 25. Left Justified Format.....	45
Figure 26. Right Justified.....	45
Figure 27. Multi-Channel Format (M == 20)	45

LIST OF TABLES

Table 1. Silicon Revisions	20
Table 2. Host Modes	33
Table 3. Host Memory Map	34
Table 4. Intel Parallel Host Mode Pin Assignments.....	34
Table 5. Parallel Input/Output Registers.....	35
Table 6. Motorola Parallel Host Mode Pin Assignments	36
Table 7. SPI Serial Mode Pin Assignments.....	36
Table 8. I ² C Serial Mode Pin Assignments	39
Table 9. Memory Interface Pins.....	41
Table 10. Digital Audio Input Port.....	46
Table 11. Compressed Data Input Port.....	46
Table 12. Digital Audio Output Port.....	47
Table 13. MCLK/SCLK Master Mode Ratios	47

1. CHARACTERISTICS AND SPECIFICATIONS

ABSOLUTE MAXIMUM RATINGS

(AGND, DGND = 0 V; all voltages with respect to 0 V)

Parameter	Symbol	Min	Max	Unit	
DC power supplies:	Positive digital	VD	-0.3	3.63	V
	Positive analog	VA	-0.3	3.63	V
	$ VA - VD $	-	0.4	V	
Input current, any pin except supplies	I_{in}	-	± 10	mA	
Digital input voltage	V_{IND}	-0.3	5.5	V	
Ambient operating temperature (power applied)	T_{Amax}	-55	125	°C	
Storage temperature	T_{stg}	-65	150	°C	

WARNING: Operation at or beyond these limits may result in permanent damage to the device.
Normal operation is not guaranteed at these extremes.

RECOMMENDED OPERATING CONDITIONS

(AGND, DGND = 0 V; all voltages with respect to 0 V)

Parameter	Symbol	Min	Typ	Max	Unit	
DC power supplies:	Positive digital	VD	3.13	3.3	3.47	V
	Positive analog	VA	3.13	3.3	3.47	V
	$ VA - VD $	-	-	0.4	V	
Ambient operating temperature	T_A	0	-	70	°C	

DIGITAL D.C. CHARACTERISTICS

($T_A = 25\text{ °C}$; VA, VD[3:1] = 3.3 V $\pm 5\%$; measurements performed under static conditions.)

Parameter	Symbol	Min	Typ	Max	Unit
High-level input voltage	V_{IH}	2.0	-	-	V
Low-level input voltage	V_{IL}	-	-	0.8	V
High-level output voltage at $I_O = -4.0\text{ mA}$	V_{OH}	$VD \times 0.9$	-	-	V
Low-level output voltage at $I_O = 4.0\text{ mA}$	V_{OL}	-	-	$VD \times 0.1$	V
Input leakage current	I_{in}	-	-	1.0	μA

POWER SUPPLY CHARACTERISTICS

($T_A = 25\text{ °C}$; VA, VD[3:1] = 3.3 V $\pm 5\%$; measurements performed under operating conditions)

Parameter	Symbol	Min	Typ	Max	Unit
Power supply current:	Digital operating: VD[3:1]	-	225	435	mA
	Analog operating: VA	-	4	8	mA

SWITCHING CHARACTERISTICS—RESET

($T_A = 25\text{ }^\circ\text{C}$; $V_A, V_D = 3.3\text{ V} \pm 5\%$; Inputs: Logic 0 = DGND, Logic 1 = VD, $C_L = 20\text{ pF}$)z

Parameter	Symbol	Min	Max	Unit
RESET minimum pulse width low	T_{rstl}	100	-	ns
All bidirectional pins high-Z after RESET low	T_{rst2z}	-	50	ns
Configuration bits setup before RESET high	T_{rstsu}	50	-	ns
Configuration bits hold after RESET high	T_{rsthd}	15	-	ns

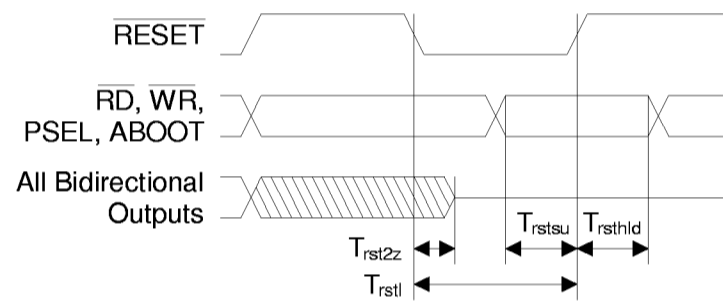

Figure 1. RESET Timing

SWITCHING CHARACTERISTICS—CMPDAT, CMPCLK

($T_A = 25\text{ }^\circ\text{C}$; $V_A, V_D = 3.3\text{ V} \pm 5\%$; Inputs: Logic 0 = DGND, Logic 1 = V_D , $C_L = 20\text{ pF}$)

Parameter	Symbol	Min	Max	Unit
Serial compressed data clock CMPCLK period	T_{cmpclk}	37	-	ns
CMPDAT setup before CMPCLK high	T_{cmprsu}	5	-	ns
CMPDAT hold after CMPCLK high	T_{cmprhd}	3	-	ns

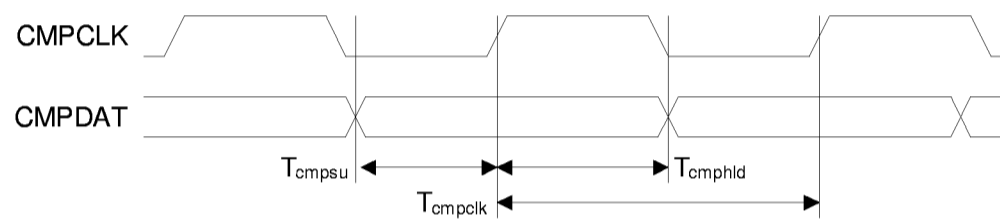

Figure 2. Serial Compressed Data Timing

SWITCHING CHARACTERISTICS—CLKIN

($T_A = 25\text{ }^\circ\text{C}$; $V_A, V_D = 3.3\text{ V} \pm 5\%$; Inputs: Logic 0 = DGND, Logic 1 = VD, $C_L = 20\text{ pF}$)

Parameter	Symbol	Min	Max	Unit
CLKIN period for internal DSP clock mode	T_{clki}	20	3800	ns
CLKIN high time for internal DSP clock mode	T_{clkih}	8		ns
CLKIN low time for internal DSP clock mode	T_{clkil}	8		ns
CLKIN period for external DSP clock mode	T_{clke}	20	25	ns
CLKIN high time for external DSP clock mode	T_{clkeh}	9		ns
CLKIN low time for external DSP clock mode	T_{clkel}	9		ns

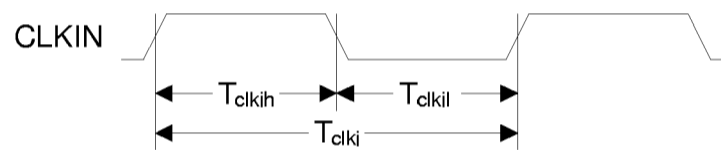

Figure 3. CLKIN with CLKSEL = VSS = PLL Enable

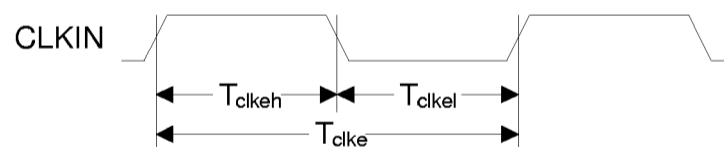

Figure 4. CLKIN with CLKSEL = VD = PLL Bypass

**SWITCHING CHARACTERISTICS—INTEL® HOST MODE**(T_A = 25 °C; V_A, V_D = 3.3 V ±5%; Inputs: Logic 0 = DGND, Logic 1 = V_D, C_L = 20 pF)

Parameter	Symbol	Min	Max	Unit
Address setup before \overline{CS} and \overline{RD} low or \overline{CS} and \overline{WR} low	T _{ias}	5	-	ns
Address hold time after \overline{CS} and \overline{RD} low or \overline{CS} and \overline{WR} low	T _{iah}	5	-	ns
Delay between \overline{RD} then \overline{CS} low or \overline{CS} then \overline{RD} low	T _{icdr}	0	∞	ns
Data valid after \overline{CS} and \overline{RD} low	T _{idd}	-	20	ns
\overline{CS} and \overline{RD} low for read (Note 1)	T _{irpw}	DCLK + 10	-	ns
Data hold time after \overline{CS} or \overline{RD} high	T _{idhr}	5	-	ns
Data high-Z after \overline{CS} or \overline{RD} high (Note 2)	T _{idis}	-	15	ns
\overline{CS} or \overline{RD} high to \overline{CS} and \overline{RD} low for next read (Note 1)	T _{ird}	2*DCLK + 10	-	ns
\overline{CS} or \overline{RD} high to \overline{CS} and \overline{WR} low for next write (Note 1)	T _{irdtw}	2*DCLK + 10	-	ns
Delay between \overline{WR} then \overline{CS} low or \overline{CS} then \overline{WR} low	T _{icdw}	0	∞	ns
Data setup before \overline{CS} or \overline{WR} high	T _{idsu}	20	-	ns
\overline{CS} and \overline{WR} low for write (Note 1)	T _{iwpw}	DCLK + 10	-	ns
Data hold after \overline{CS} or \overline{WR} high	T _{idhw}	5	-	ns
\overline{CS} or \overline{WR} high to \overline{CS} and \overline{RD} low for next read (Note 1)	T _{iwtrd}	2*DCLK + 10	-	ns
\overline{CS} or \overline{WR} high to \overline{CS} and \overline{WR} low for next write (Note 1)	T _{iwd}	2*DCLK + 10	-	ns

Notes: 1. Certain timing parameters are normalized to the DSP clock, DCLK, in nanoseconds. The DSP clock can be defined as follows:

External CLKIN Mode:
DCLK == CLKIN/3 before and during boot
DCLK == CLKIN after boot

Internal Clock Mode:
DCLK == 10MHz before and during boot, i.e. DCLK == 100ns
DCLK == 60 MHz after boot, i.e. DCLK == 16.7ns (this speed may depend on CLKIN, please see CS4923/4/5/6/7/8/9 Hardware User's Guide for more information)

2. This specification is characterized but not production tested.

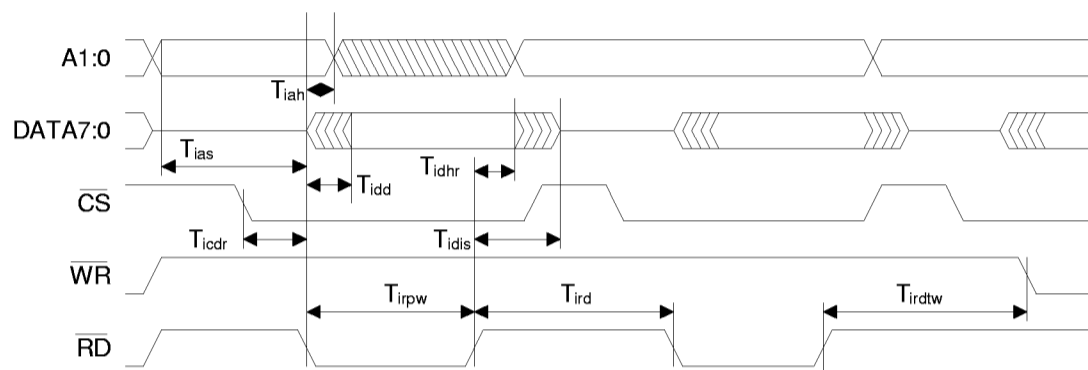

Figure 5. Intel Parallel Host Mode Read Cycle

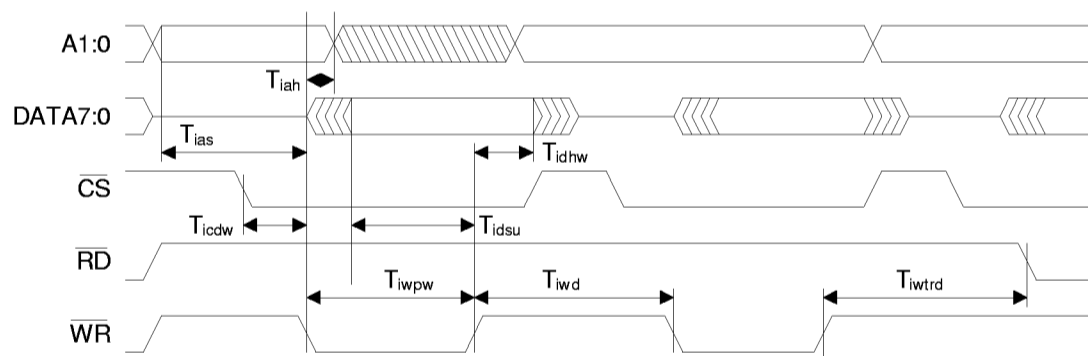

Figure 6. Intel Parallel Host Mode Write Cycle



SWITCHING CHARACTERISTICS—MOTOROLA® HOST MODE

(T_A = 25 °C; V_A, V_D = 3.3 V ±5%; Inputs: Logic 0 = DGND, Logic 1 = V_D, C_L = 20 pF)

Parameter	Symbol	Min	Max	Unit
Address setup before \overline{CS} and \overline{DS} low	T _{mas}	5	-	ns
Address hold time after \overline{CS} and \overline{DS} low	T _{mah}	5	-	ns
Delay between \overline{DS} then \overline{CS} low or \overline{CS} then \overline{DS} low	T _{mcdl}	0	∞	ns
Data valid after \overline{CS} and \overline{DS} low with R/W high	T _{mdv}	-	20	ns
\overline{CS} and \overline{DS} low for read (Note 3)	T _{mrpw}	DCLK + 10	-	ns
Data hold time after \overline{CS} or \overline{DS} high after read	T _{mdhr}	5	-	ns
Data high-Z after \overline{CS} or \overline{DS} high low after read (Note 4)	T _{mdis}	-	15	ns
\overline{CS} or \overline{DS} high to \overline{CS} and \overline{DS} low for next read (Note 3)	T _{mrd}	2*DCLK + 10	-	ns
\overline{CS} or \overline{DS} high to \overline{CS} and \overline{DS} low for next write (Note 3)	T _{mrdtw}	2*DCLK + 10	-	ns
Delay between \overline{DS} then \overline{CS} low or \overline{CS} then \overline{DS} low	T _{mcdw}	0	∞	ns
Data setup before \overline{CS} or \overline{DS} high	T _{mdsu}	20	-	ns
\overline{CS} and \overline{DS} low for write (Note 3)	T _{mwpw}	DCLK + 10	-	ns
R/W setup before \overline{CS} or \overline{DS} low	T _{mrwsu}	5	-	ns
R/W hold time after \overline{CS} or \overline{DS} high	T _{mrwhld}	5	-	ns
Data hold after \overline{CS} or \overline{DS} high	T _{mdhw}	5	-	ns
\overline{CS} or \overline{DS} high to \overline{CS} and \overline{DS} low with R/W high for next read (Note 3)	T _{mwtrd}	2*DCLK + 10	-	ns
\overline{CS} or \overline{DS} high to \overline{CS} and \overline{DS} low for next write (Note 3)	T _{mwd}	2*DCLK + 10	-	ns

Notes: 3. Certain timing parameters are normalized to the DSP clock, DCLK, in nanoseconds. The DSP clock can be defined as follows:

External CLKIN Mode:
 DCLK == CLKIN/3 before and during boot
 DCLK == CLKIN after boot

Internal Clock Mode:
 DCLK == 10MHz before and during boot, i.e. DCLK == 100ns
 DCLK == 60 MHz after boot, i.e. DCLK == 16.7ns (this speed may depend on CLKIN, please see CS4923/4/5/6/7/8/9 Hardware Users Guide for more information)

4. This specification is characterized but not production tested.

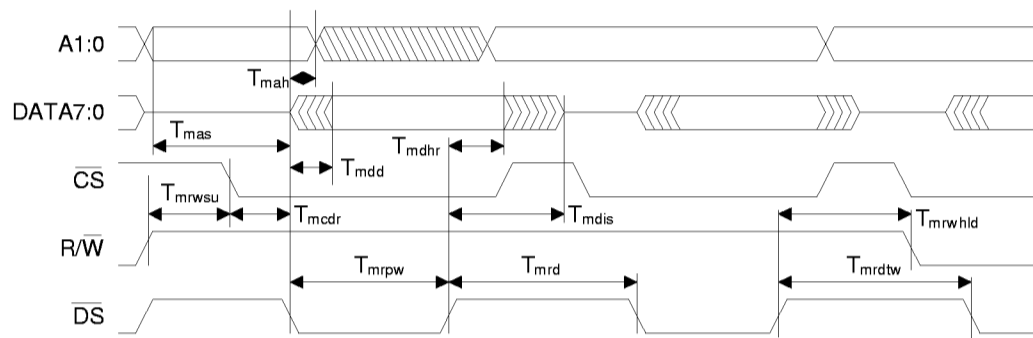

Figure 7. Motorola Parallel Host Mode Read Cycle

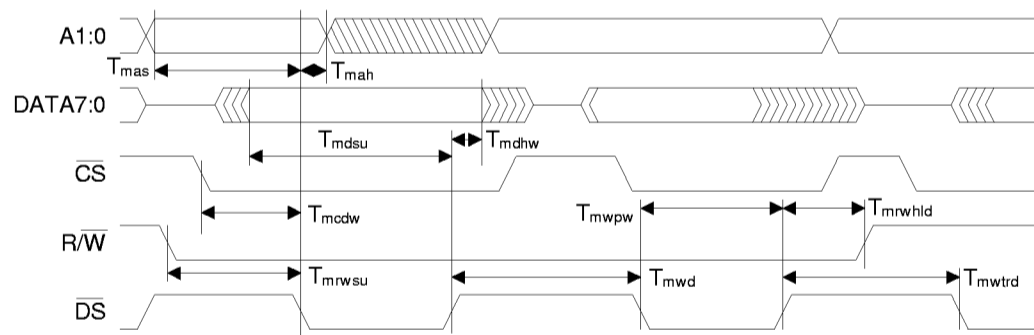

Figure 8. Motorola Parallel Host Mode Write Cycle

SWITCHING CHARACTERISTICS—SPI CONTROL PORT

 (T_A = 25 °C; V_A, V_D = 3.3 V ±5%; Inputs: Logic 0 = DGND, Logic 1 = V_D, C_L = 20 pF)

Parameter	Symbol	Min	Max	Units
SCCLK clock frequency (Note 5)	f _{sck}	-	2000	kHz
CS falling to SCCLK rising	t _{css}	20	-	ns
Rise time of SCCLK line (Note 11)	t _r	-	50	ns
Fall time of SCCLK lines (Note 11)	t _f	-	50	ns
SCCLK low time	t _{scl}	150	-	ns
SCCLK high time	t _{sch}	150	-	ns
Setup time SCDIN to SCCLK rising	t _{cdisu}	50	-	ns
Hold time SCCLK rising to SCDIN (Note 6)	t _{cdih}	50	-	ns
Transition time from SCCLK to SCDOUT valid (Note 7)	t _{scdov}	-	40	ns
Time from SCCLK rising to INTREQ rising (Note 8)	t _{scrh}	-	200	ns
Rise time for INTREQ (Note 8)	t _{rr}	-	(Note 10)	ns
Hold time for INTREQ from SCCLK rising (Note 9, 11)	t _{scri}	0	-	ns
Time from SCCLK falling to CS rising	t _{scssh}	20	-	ns
High time between active CS	t _{csht}	200	-	ns
Time from CS rising to SCDOUT high-Z (Note 11)	t _{cscdo}		10	ns

- Notes:
5. The specification f_{sck} indicates the maximum speed of the hardware. The system designer should be aware that the actual maximum speed of the communication port may be limited by the software. The relevant application code user's manual should be consulted for the software speed limitations.
 6. Data must be held for sufficient time to bridge the 50 ns transition time of SCCLK.
 7. SCDOUT should *not* be sampled during this time period.
 8. INTREQ goes high only if there is no data to be read from the DSP at the rising edge of SCCLK for the second-to-last bit of the last byte of data during a read operation as shown.
 9. If INTREQ goes high as indicated in Note 8, then INTREQ is guaranteed to remain high until the next rising edge of SCCLK. If there is more data to be read at this time, INTREQ goes active low again. Treat this condition as a new read transaction. Raise chip select to end the current read transaction and then drop it, followed by the 7-bit address and the R/W bit (set to 1 for a read) to start a new read transaction.
 10. With a 4.7k Ohm pull-up resistor this value is typically 215ns. As this pin is open drain adjusting the pull up value will affect the rise time.
 11. This time is by design and not tested.

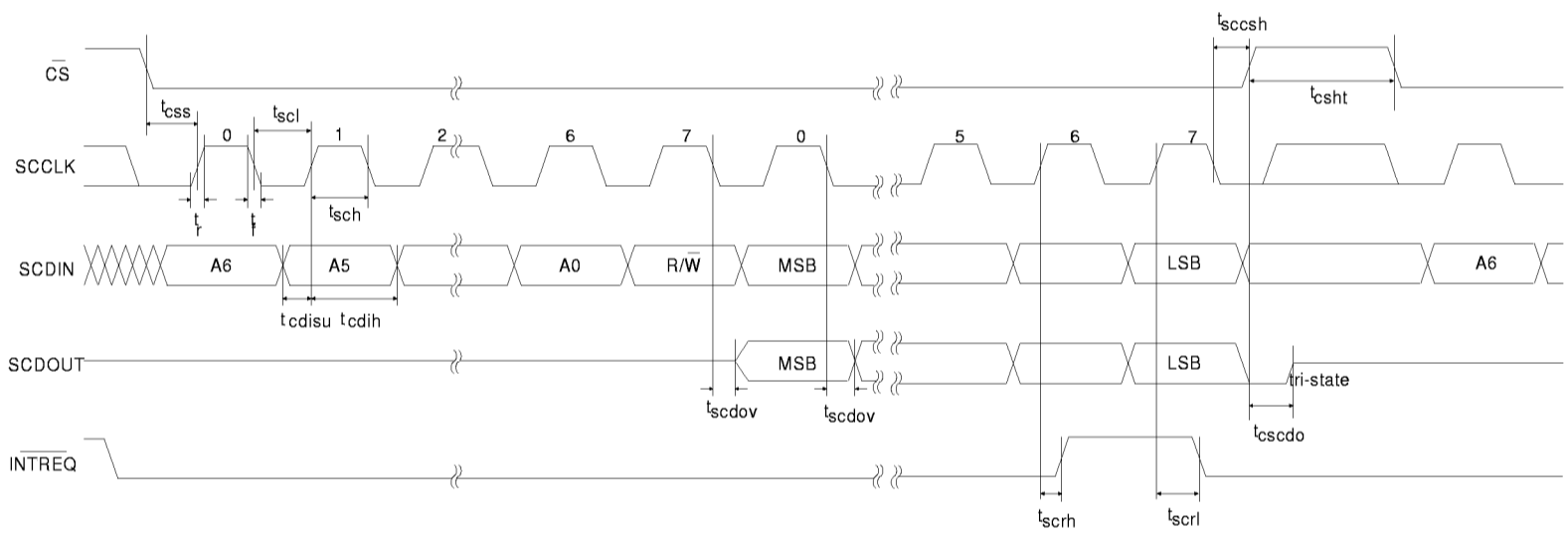

Figure 9. SPI Control Port Timing

SWITCHING CHARACTERISTICS— I²C[®] CONTROL PORT

 (T_A = 25 °C; V_A, V_D = 3.3 V ±5%; Inputs: Logic 0 = DGND, Logic 1 = V_D, C_L = 20 pF)

Parameter	Symbol	Min	Max	Units
SCCLK clock frequency (Note 12)	f _{scl}		400	kHz
Bus free time between transmissions	t _{buf}	4.7		μs
Start-condition hold time (prior to first clock pulse)	t _{hdst}	4.0		μs
Clock low time	t _{low}	1.2		μs
Clock high time	t _{high}	1.0		μs
SCDIO setup time to SCCLK rising	t _{sud}	250		ns
SCDIO hold time from SCCLK falling (Note 13)	t _{hdd}	0		μs
Rise time of SCCLK (Note 14), (Note 18)	t _r		50	ns
Fall time of SCCLK (Note 18)	t _f		300	ns
Time from SCCLK falling to CS4923/4/5/6/7/8/9 ACK	t _{sca}		40	ns
Time from SCCLK falling to SCDIO valid during read operation	t _{sdsdv}		40	ns
Time from SCCLK rising to INTREQ rising (Note 15)	t _{scrh}		200	ns
Hold time for INTREQ from SCCLK rising (Note 16)	t _{scri}	0		ns
Rise time for INTREQ	t _{rr}		(Note 17)	ns
Setup time for stop condition	t _{susp}	4.7		μs

- Notes: 12. The specification f_{scl} indicates the maximum speed of the hardware. The system designer should be aware that the actual maximum speed of the communication port may be limited by the software. The relevant application code user's manual should be consulted for the software speed limitations.
13. Data must be held for sufficient time to bridge the 300-ns transition time of SCCLK. This hold time is by design and not tested.
14. This rise time is shorter than that recommended by the I²C specifications. For more information, see the section on SCP communications.
15. INTREQ goes high only if there is no data to be read from the DSP at the rising edge of SCCLK for the last data bit of the last byte of data during a read operation as shown.
16. If INTREQ goes high as indicated in Note 8, then INTREQ is guaranteed to remain high until the next rising edge of SCCLK. If there is more data to be read at this time, INTREQ goes active low again. Treat this condition as a new read transaction. Send a new start condition followed by the 7-bit address and the R/W bit (set to 1 for a read). This time is by design and is not tested.
17. With a 4.7k Ohm pull-up resistor this value is typically 215ns. As this pin is open drain adjusting the pull up value will affect the rise time.
18. This time is by design and not tested.

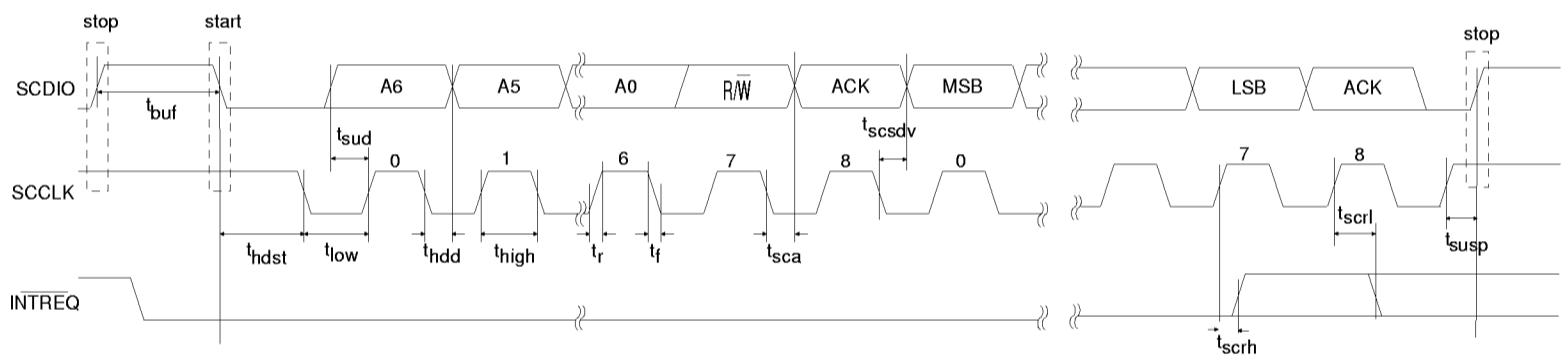
 Figure 10. I²C Control Port Timing

**SWITCHING CHARACTERISTICS—DIGITAL AUDIO INPUT**(T_A = 25 °C; V_A, V_D = 3.3 V ±5%; Inputs: Logic 0 = DGND, Logic 1 = V_D, C_L = 20 pF)

Parameter	Symbol	Min	Max	Unit
SCLKN1(2) period for both Master and Slave mode (Note 19)	T _{sclki}	40	-	ns
SCLKN1(2) duty cycle for Master and Slave mode (Note 19)		45	55	%
Master Mode (Note 19,20)				
LRCLKN1(2) delay after SCLKN1(2) transition (Note 21)	T _{lrds}	-	10	ns
SDATAN1(2) setup to SCLKN1(2) transition (Note 22)	T _{sdsu}	10	-	ns
SDATAN1(2) hold time after SCLKN1(2) transition (Note 22)	T _{sdhm}	5	-	ns
Slave Mode (Note 23)				
Time from active edge of SCLKN1(2) to LRCLKN1(2) transition	T _{stlr}	10	-	ns
Time from LRCLKN1(2) transition to SCLKN1(2) active edge	T _{lrts}	10	-	ns
SDATAN1(2) setup to SCLKN1(2) transition (Note 22)	T _{sdsus}	5	-	ns
SDATAN1(2) hold time after SCLKN1(2) transition (Note 22)	T _{sdhs}	5	-	ns

Notes: 19. Master mode timing specifications are characterized, not production tested.

20. Master mode is defined as the CS4923 driving LRCLKN1(2) and SCLKN1(2). Master or Slave mode can be programmed.

21. This timing parameter is defined from the non-active edge of SCLKN1(2). The active edge of SCLKN1(2) is the point at which the data is valid.

22. This timing parameter is defined from the active edge of SCLKN1(2). The active edge of SCLKN1(2) is the point at which the data is valid.

23. Slave mode is defined as SCLKN1(2) and LRCLKN1(2) being driven by an external source.

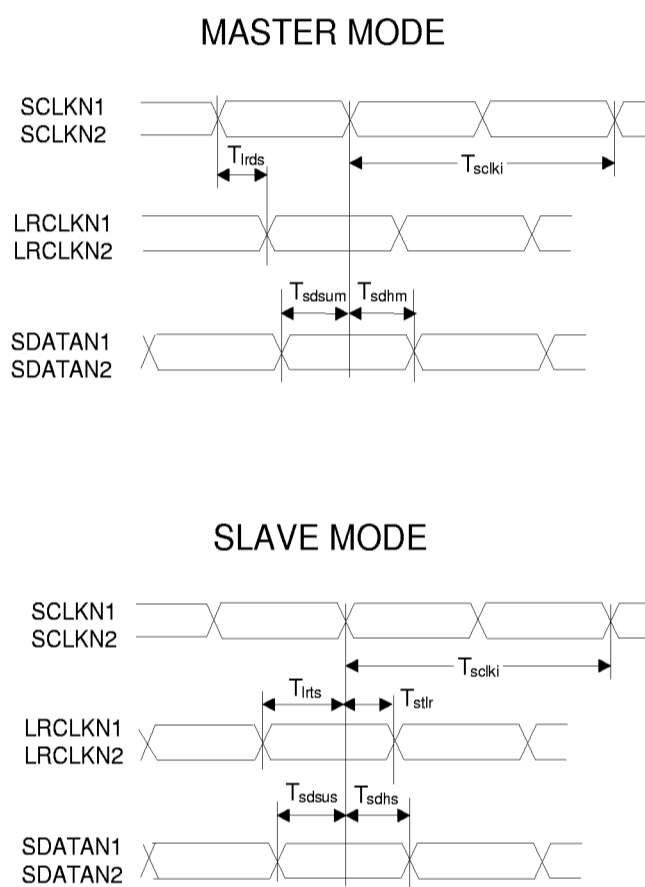

Figure 11. Digital Audio Input, Data and Clock Timing

**SWITCHING CHARACTERISTICS—DIGITAL AUDIO OUTPUT**(T_A = 25 °C; V_A, V_D = 3.3 V ±5%; measurements performed under static conditions.)

Parameter	Symbol	Min	Max	Unit
MCLK period (Note 24)	T _{mclk}	40	-	ns
MCLK duty cycle (Note 24)		40	60	%
SCLK period for Master or Slave mode (Note 25)	T _{sclk}	40	-	ns
SCLK duty cycle for Master or Slave mode (Note 25)		45	55	%
Master Mode (Note 25,26)				
SCLK delay from MCLK rising edge, MCLK as an input	T _{sdmi}		15	ns
SCLK delay from MCLK rising edge, MCLK as an output	T _{sdmo}	-5	10	ns
LRCLK delay from SCLK transition (Note 27)	T _{lrds}		10	ns
AUDATA2-0 delay from SCLK transition (Note 27)	T _{adsm}		10	ns
Slave Mode (Note 28)				
Time from active edge of SCLKN1(2) to LRCLKN1(2) transition	T _{stlr}	10	-	ns
Time from LRCLKN1(2) transition to SCLKN1(2) active edge	T _{lrts}	10	-	ns
AUDATA2-0 delay from SCLK transition (Note 27,29)	T _{adss}		15	ns

Notes: 24. MCLK can be an input or an output. These specifications apply for both cases.

25. Master mode timing specifications are characterized, not production tested.

26. Master mode is defined as the CS4923 driving both SCLK and LRCLK. When MCLK is an input, it is divided to produce SCLK and LRCLK.

27. This timing parameter is defined from the non-active edge of SCLK. The active edge of SCLK is the point at which the data is valid.

28. Slave mode is defined as SCLK and LRCLK being driven by an external source.

29. This specification is characterized, not production tested.

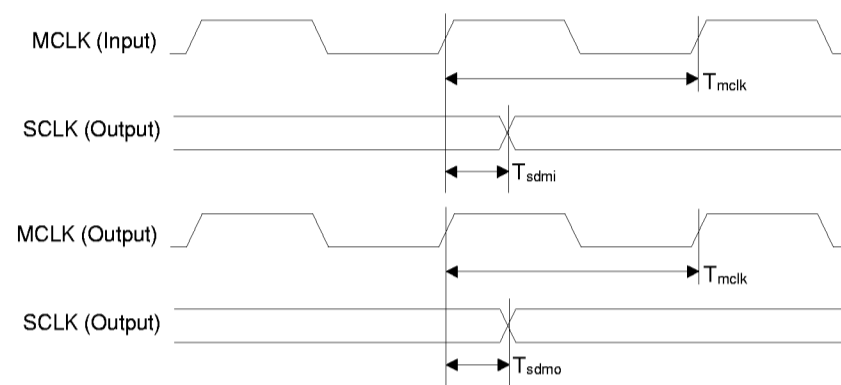

MASTER MODE

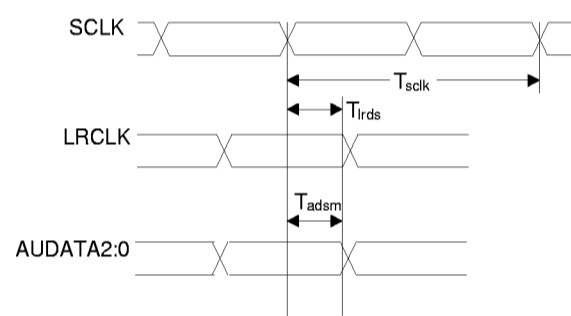

SLAVE MODE

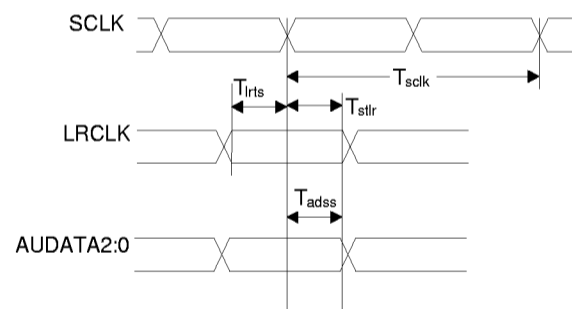

Figure 12. Digital Audio Output, Data and Clock Timing

2. FAMILY OVERVIEW

The CS4923, CS4924, CS4925, CS4926, CS4927, CS4928 and the CS4929 are system on a chip solutions for multi-channel (or stereo in the case of the CS4929) audio decompression and digital signal processing. Because the parts are primarily RAM-based, a download of application software is required each time the CS4923/4/5/6/7/8/9 is powered up. This document uses “download” and “code load” interchangeably. These terms should be interpreted as meaning the transfer of application code into the internal CS4923/4/5/6/7/8/9 memory from either an external microcontroller or through the autoboot procedure.

This document focuses on the electrical features and characteristics of these parts. The different features are described from a hardware design perspective. It should be understood that not all of the features portrayed in this document are supported by all of the versions of application code available. The application user’s guides (see section 2.2.2) should be consulted to confirm which hardware features are supported by the software. This document will be valuable to both the hardware designer and the system programmer.

This data sheet covers the CS4923, CS4924, CS4925, CS4926, CS4927, CS4928 and CS4929. These parts are identical from an external electrical perspective. Internally each device has been tailored for supporting different decoding standards. For this document CS4923/4/5/6/7/8/9 has been replaced in certain places with CS492X for readability. Unless otherwise specified CS492X should be interpreted as applying to the CS4923, CS4924, CS4925, CS4926, CS4927, CS4928 and CS4929.

There are two revisions of silicon commercially available. The features available on Revision D are a super-set of those features available on Revision B. Differences between the revisions are pointed

out when features are discussed within this document. The silicon revision for any chip can be determined by referencing Table 1 below.

Revision B	Revision D
CS492301	CS492305
CS492401	CS492405
CS492501	CS492505
CS492603	CS492604
	CS492705
	CS492804
	CS492906

Table 1. Silicon Revisions

These parts are generally targeted at two different market segments. The broadcast market where audio/video (A/V) synchronization is required, and the outboard decoder markets where audio/video synchronization is not required. The important differentiation is the format in which the data will be received by the CS4923/4/5/6/7/8/9. In systems where A/V synchronization is required from the CS4923/4/5/6/7/8/9, the incoming data is typically PES encoded. In an outboard decoder application the data typically comes in the IEC61937 format (as specified by the DVD consortium). An important point to remember is that the CS4923/4/5/6/7/8/9 will support both environments, but different downloads are required depending on the input data type.

Broadcast applications include (but are not limited to) set top box applications, DVDs and digital TVs. Outboard decoder applications include standalone decoders and audio/video receivers. Often times a system may be a hybrid between an outboard decoder and a broadcast system depending on its functionality.

As discussed above, compressed audio can be packed in IEC61937, PES, or elementary formats depending on the decoder environment. Each format is supported by a separate download of application code. Consult the relevant Application Code

User's Guide to determine which formats are supported by a particular application. A brief description of each format is presented below.

Elementary - an elementary bitstream consists only of compressed audio data (e.g., strictly the Dolby Digital bitstream); used primarily in broadcast environments.

PES - a Packetized Elementary Stream (PES) bitstream contains the elementary compressed audio stream and additional header information which can be used for A/V synchronization; used primarily in broadcast environments.

IEC61937 - a method of packing compressed audio such that it can be delivered using a bi-phase encoded signal (e.g., S/PDIF output signal from DVD player); used primarily for outboard decoders where A/V synchronization is not required.

2.1 Multi-channel Decoder Family of Parts

CS4923 - Dolby Digital™ Audio Decoder. The CS4923 is the original member of the family and is intended to be used if only Dolby Digital decoding is required. For Dolby Digital, post processing includes bass management, delays and Dolby Pro Logic decoding. Separate downloads can also be used to support stereo to 5.1 channel effects processing and stereo MPEG decoding.

CS4924 - Dolby Digital™ Source Product Decoder. The CS4924 is the stereo version of the CS4923 designed for source products such as DVD, HDTV, and set-top boxes. Separate downloads are available for stereo decode of Dolby Digital and MPEG audio.

CS4925 - International Multi-Channel DVD Audio Decoder. The CS4925 supports both Dolby Digital and MPEG-2 multi-channel formats. For both Dolby Digital and MPEG-2 multi-channel, post processing includes bass management and Dolby Pro Logic decoding. Separate downloads are available for decode of Dolby Digital and MPEG

audio. Another code load can be used to support stereo to 5.1 channel effects processing.

CS4926 - DTS/Dolby® Multi-Channel Audio Decoder. The CS4926 supports both Dolby Digital and DTS, or Digital Theater Surround. For Dolby Digital, post processing includes bass management and Dolby Pro Logic. The Dolby Digital code and DTS code take separate code downloads. Separate downloads can also be used to support stereo to 5.1 channel effects processing and stereo MPEG decoding.

CS4927 - MPEG-2 Multi-Channel Decoder. The CS4927 supports MPEG-2 multi-channel decoding and should be used in applications where Dolby Digital decoding is not necessary. For MPEG-2 multi-channel decoding, post processing includes bass management and Dolby Pro Logic decoding. Another code load can be used to support stereo to 5.1 channel effects processing.

CS4928 - DTS Multi-Channel Decoder. The CS4928 supports DTS multi-channel decoding and should be used in applications where Dolby Digital decoding is not necessary. For DTS multi-channel decoding, post processing includes bass management. Separate downloads can also be used to support stereo to 5.1 channel effects processing and stereo MPEG decoding.

CS4929 - AAC 2-Channel, (Low Complexity) and MPEG-2 Stereo Decoder. The CS4929 is capable of decoding both 2-channel AAC and MPEG-2 audio. The CS4929 supports elementary and PES formats.

2.2 Document Strategy

Multiple documents are needed to fully define, understand and implement the functionality of the CS4923/4/5/6/7/8/9. They can be split up into two basic groups: hardware and application code documentation. It should be noted that hardware and application code are co-dependent and one can not successfully use the device without an

understanding of both. The 'ANXXX' notation denotes the application note number under which the respective user's guide was released.

2.2.1 Hardware Documentation

CS4923/4/5/6/7/8/9 Family Data Sheet - This document describes the electrical characteristics of the device from timing to base functionality. This is the hardware designers tool to learn the part's electrical and systems requirements.

AN115 - CS4923/4/5/6/7/8/9 Hardware User's Guide - describes the functional aspects of the device. An in depth description of communication, boot procedure, external memory and hardware configuration are given in this document. This document will be valuable to both the hardware designer and the system programmer.

2.2.2 CS4923/4/5/6/7/8/9 Application Code User's Guides

The following application notes describe the application codes used with the CS4923/4/5/6/7/8/9. Whenever an application code user's guide is referred to, it should be assumed that one or more of the below documents are being referenced. The following list covers currently released application notes. This list will grow with each new application released. For a current list of released user's guides please see www.crystal.com and search for the part number.

AN120 - Dolby Digital User's Guide for the CS4923/4/5/6. This document covers the features available in the Dolby Digital code including delays, pink noise, bass management, Pro Logic, PCM pass through and Dolby Digital processing features. Optional appendices are available that document code for Dolby Virtual, Q-Surround and VMaX.

AN121 - MPEG User's Guide for the CS4925. This document covers the features available in the

MPEG Multi-Channel code including delays, bass management, Pro Logic, and MPEG processing features.

AN122 - DTS User's Guide for the CS4926, CS4928. This document covers the features available in the DTS code including bass management and DTS processing features.

AN123 - Surround User's Guide for the CS4923/4/5/6/7/8. This code covers the different Stereo PCM to surround effects processing code. Optional appendices are available that document Crystal Original Surround, Circle Surround and Logic 7.

AN140 - Broadcast Systems Guide for the CS4923/4/5/6/7/8/9. This guide describes all application code (e.g. Dolby Digital, MPEG, AAC) designed for broadcast systems such as HDTV and set-top box receivers. This document also provides a discussion of broadcast system considerations and dependencies such as A/V synchronization and channel change procedures.

2.3 Using the CS4923/4/5/6/7/8/9

No matter what application is being used on the chip, the following four steps are always followed to use the CS4923/4/5/6/7/8/9 in system.

- 1) Reset and/or Download Code - Detailed information in AN115
- 2) Hardware Configuration - Detailed information in AN115
- 3) Application configuration - Detailed information in the appropriate Application Code User's guide
- 4) Kickstart - This is the "Go" command to the CS492X once the system is properly configured. Information can be found in the appropriate Application Code User's guide.

3. TYPICAL CONNECTION DIAGRAMS

Six typical connection diagrams have been presented to illustrate using the device with the different communication modes available. They are as follows:

Figure 13: I²C Control

Figure 14: I²C Control with External Memory

Figure 15: SPI Control

Figure 16: SPI Control with External Memory

Figure 17: Intel Parallel Control Mode

Figure 18: Motorola Parallel Control Mode

The following should be noted when viewing the typical connection diagrams:

The pins are grouped functionally in each of the typical connection diagrams. Please be aware that the CS4923/4/5/6/7/8/9 symbol may appear differently in each diagram.

The external memory interface is only supported when a serial communication mode has been chosen.

The typical connection diagrams demonstrate the PLL being used (CLKSEL is pulled low). To enable external CLKIN, CLKSEL should be pulled high. The system designer must be aware that certain software features may not be available if external CLKIN is used as the DSP must run slower when external CLKIN is used. The system designer should also be aware of additional duty cycle requirements when using external CLKIN mode. It is highly suggested that the system designer take advantage of the PLL and pull CLKSEL low.

3.1 Multiplexed Pins

The CS4923/4/5/6/7/8/9 family of digital signal processors (DSPs) incorporate a large amount of flexibility into a 44 pin package. Because of the high degree of integration, many of these pins are internally multiplexed to serve multiple purposes.

Some pins are designed to operate in one mode at power up, and serve a different purpose when the DSP is running. Other pins have functionality which can be controlled by the application running on the DSP. In order to better explain the behavior of the part, the pins which are multiplexed have been given multiple names. Each name is specific to the pin's operation in a particular mode.

An example of this would be the use of pin 20 in one of the serial control modes. During the boot period of the CS492X, pin 20 is called ABOOT. ABOOT is sampled on the rising edge of RESET. If ABOOT is high the host must download code to the DSP. If ABOOT is low when sampled, the CS492X goes into autoboot mode and loads itself with code by generating addresses and reading data on EMAD[7:0]. When the device has been loaded with code and is running an application, however, pin 20 is called INTREQ. INTREQ is an open drain output used to inform the host that the DSP has an outgoing message which should be read.

In this document, pins will be referred to by their functionality. The section "Pin Descriptions" on page 49 describes each pin of the CS492X and lists all of its names. Please refer to the Pin Descriptions section when exact pin numbers are in question.

The device has 12 general purpose input and output (GPIO[11:0]) pins that all have multiple functionality. While in one of the parallel communication modes (see section 6.2), these pins are used to implement the parallel host communication interface. While in one of the serial host modes these pins are used to implement an external memory interface. Alternatively while in one of the serial host modes these pins could be used for another general purpose if the application code has been programmed to support the special purpose. In this document the pins are referenced by the name corresponding to their particular use. Sometimes GPIO[11:0], or some subset thereof, is used when referring to the pins in a general sense.

3.2 Termination Requirements

The CS4923/4/5/6/7/8/9 incorporates open drain pins which must be pulled high for proper operation. $\overline{\text{INTREQ}}$ (pin 20) is always an open drain pin which requires a pull-up for proper operation. When in the I²C serial communication mode, the SCDIO signal (pin 19) is open drain and thus requires a pull-up for proper operation.

Due to the internal, multiplexed design of the pins, certain signals may or may not require termination depending on the mode being used. If a parallel host communication mode is not being used, GPIO[11:0] must be terminated or driven as these pins will come up as high impedance inputs and will be prone to oscillation if they are left floating. The specific termination requirements may vary since the state of some of the GPIO pins will determine the communication mode at the rising edge of reset (please see section 6 for more

information). For the explicit termination requirements of each communication mode please see the typical connection diagrams.

Generally a 4.7k Ohm resistor is recommended for open drain pins while a 10k Ohm resistor is sufficient for the GPIO pins and unused inputs.

3.3 Phase Locked Loop Filter

The internal phase locked loop (PLL) of the CS4923/4/5/6/7/8/9 requires an external filter for successful operation. The topology of this filter and component values are shown in the typical connection diagrams. Care should be taken when laying out the filter circuitry to minimize trace lengths and to avoid any close routing of high frequency signals. Any noise coupled on to the filter circuit will be directly coupled into the PLL, which could affect performance.

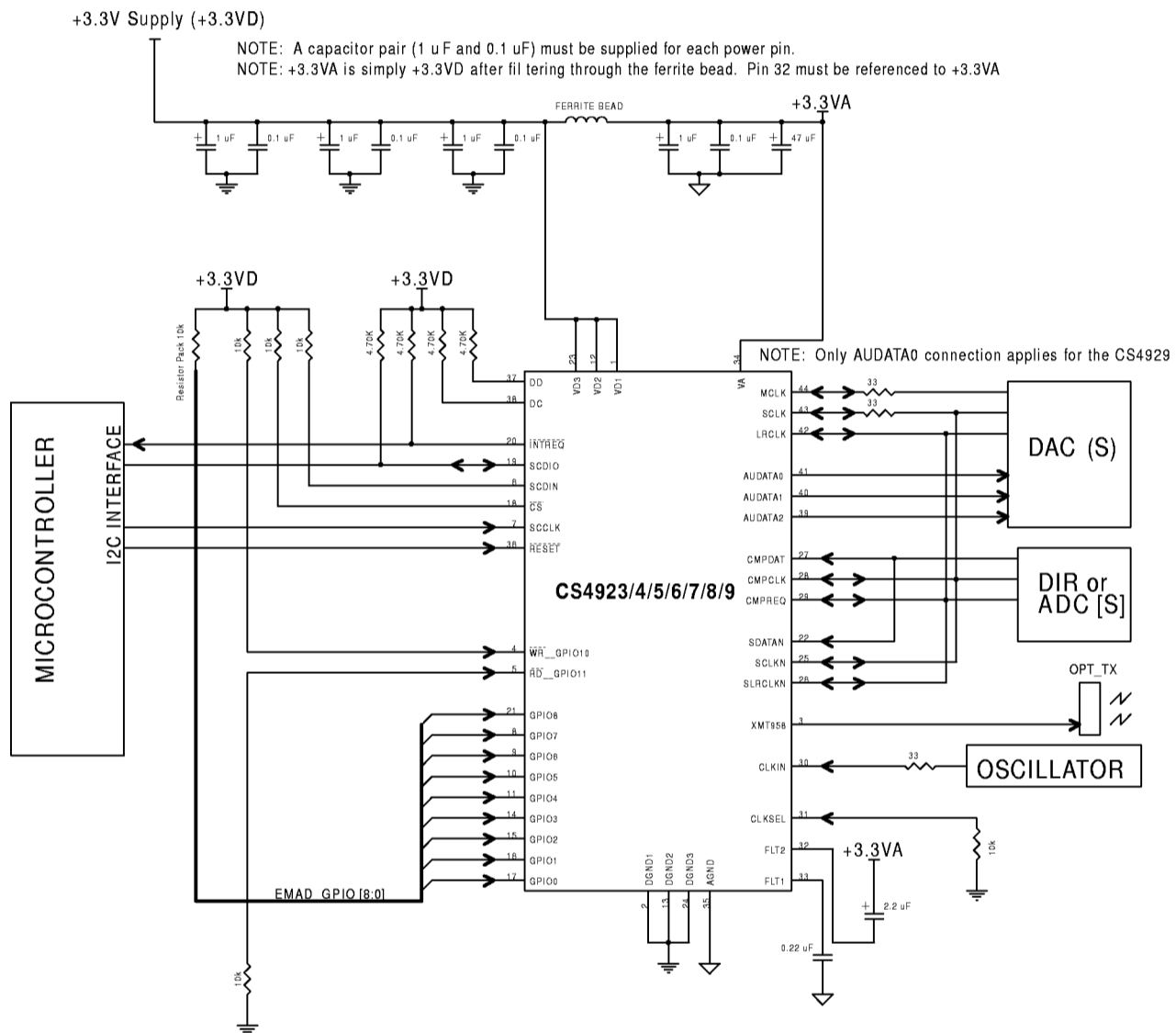

Figure 13. I²C Control

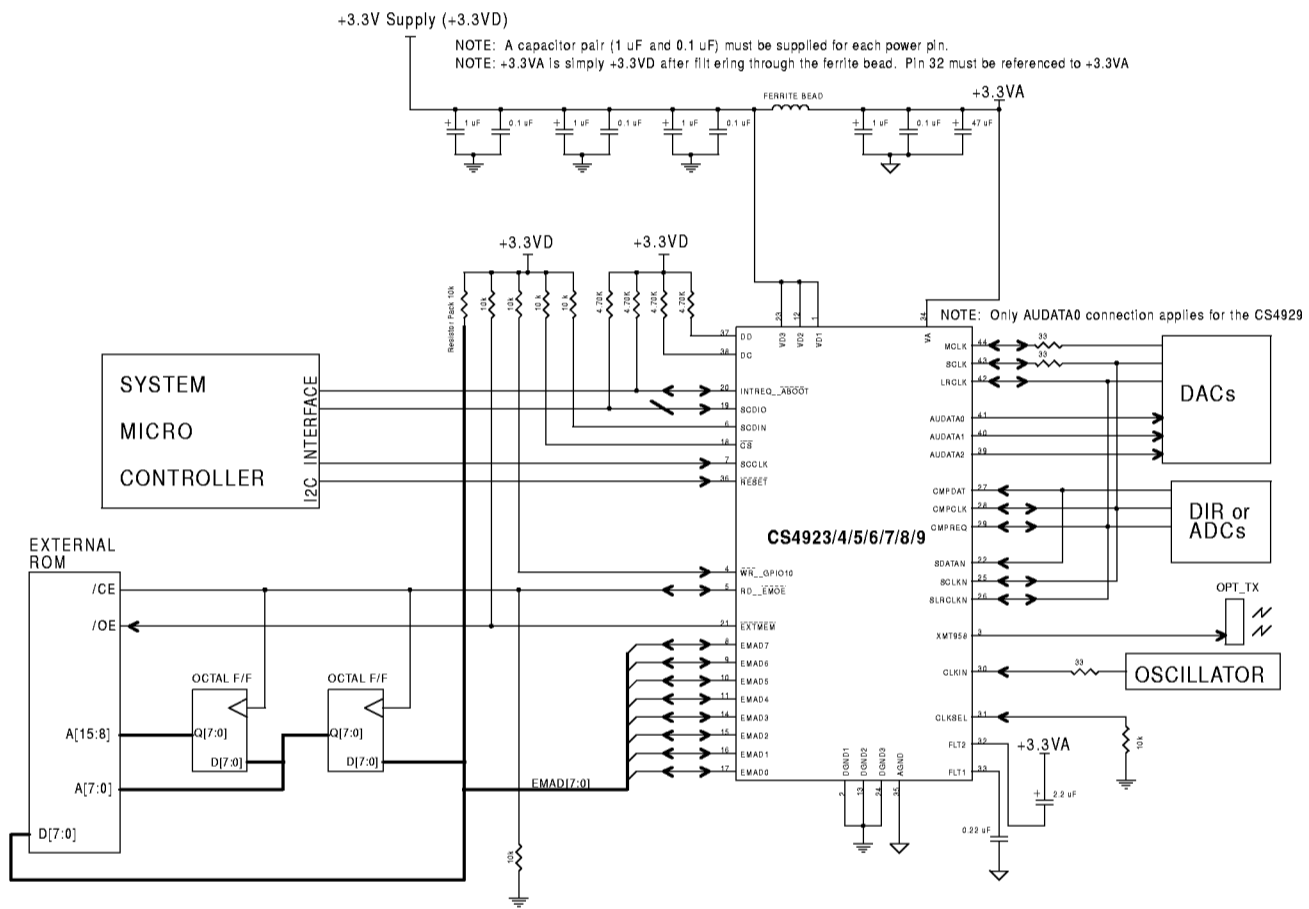

Figure 14. I²C Control with External Memory

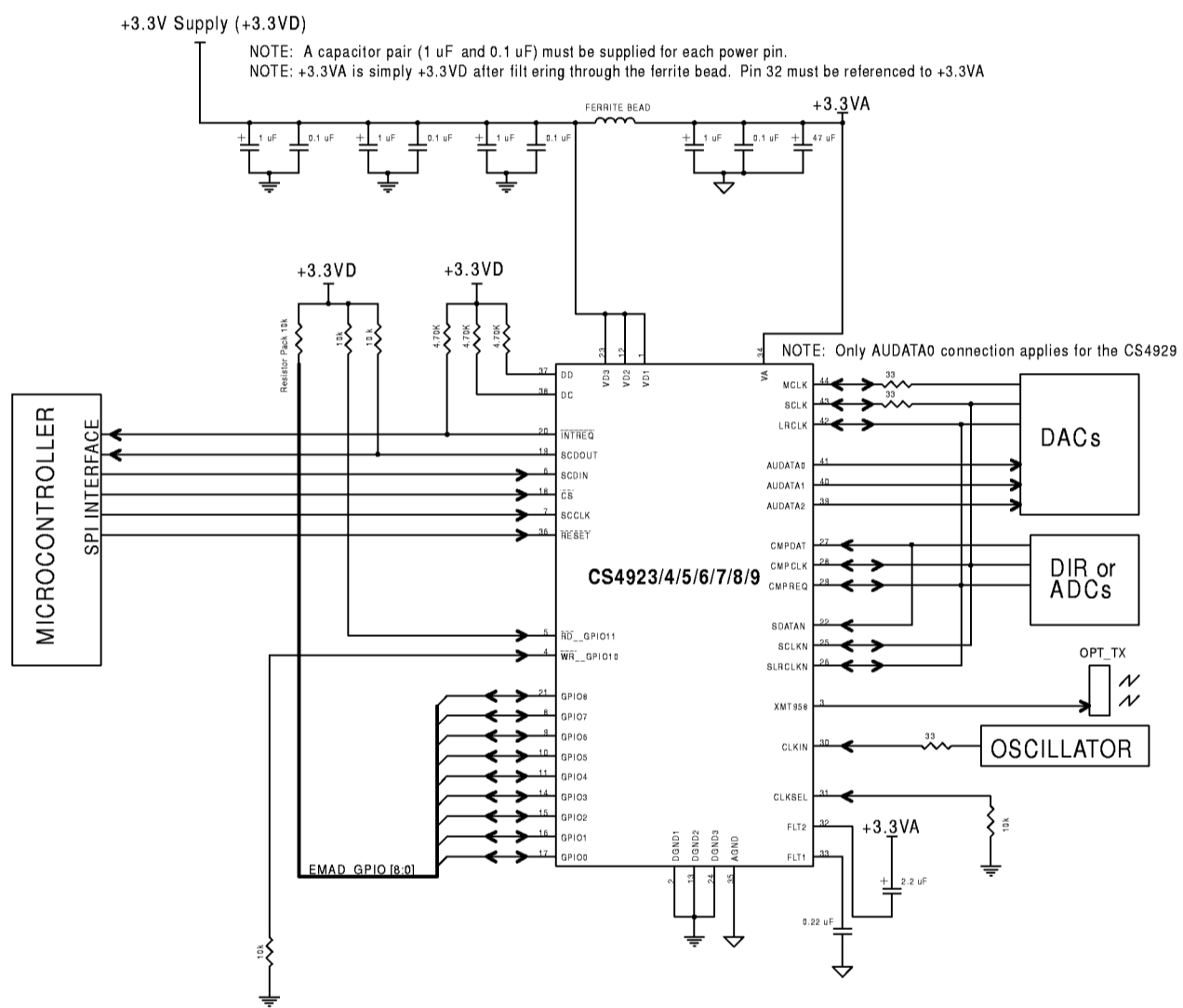

Figure 15. SPI Control

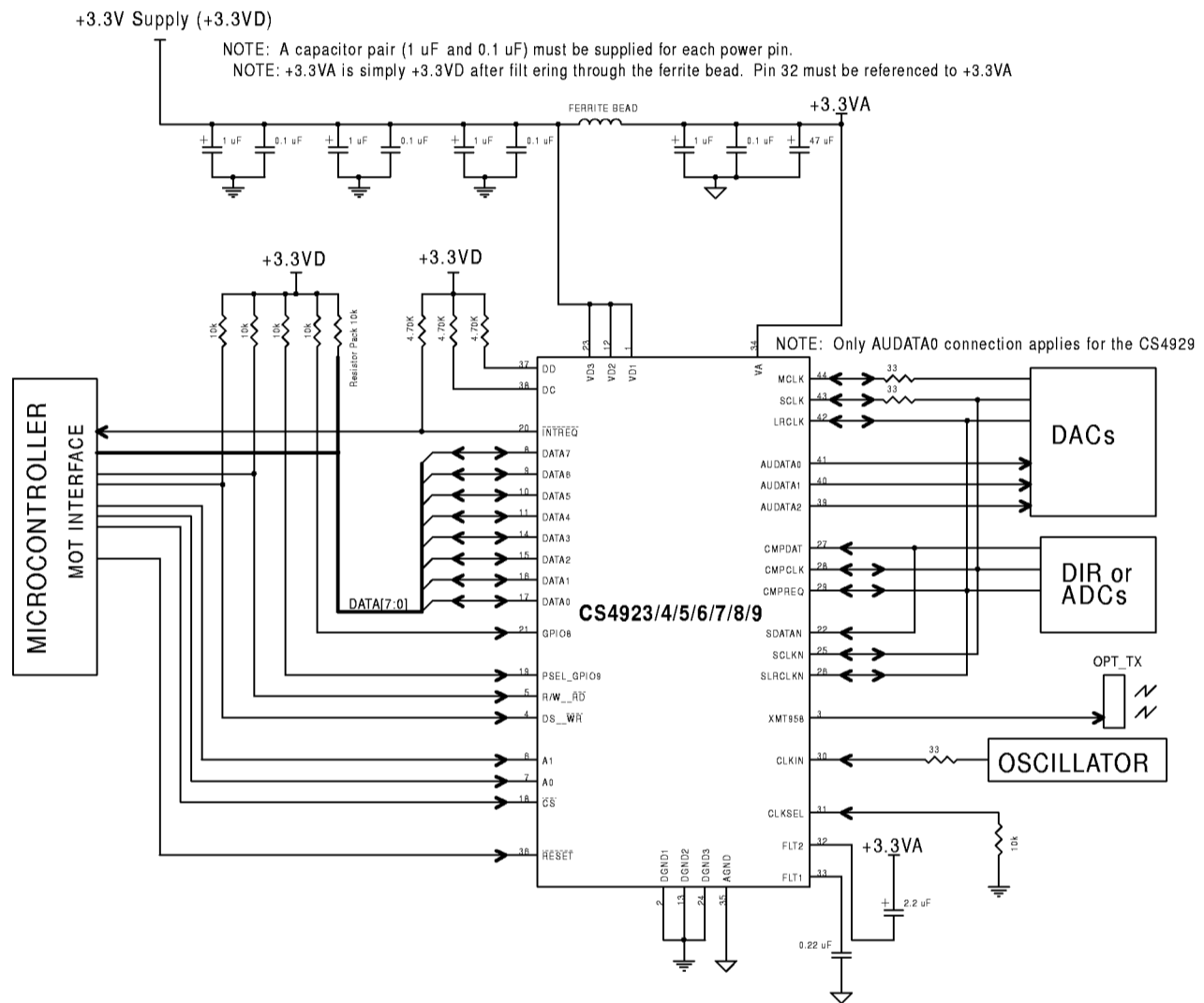

Figure 18. Motorola Parallel Control Mode

4. POWER

The CS492X requires a 3.3V digital power supply for the digital logic within the DSP and a 3.3V analog power supply for the internal PLL. There are three digital power pins, VD1, VD2 and VD3, along with three digital grounds, DGND1, DGND2 and DGND3. There is one analog power pin, VA and one analog ground, AGND. The DSP will perform at its best when noise has been eliminated from the power supply. The recommendations given below for decoupling and power conditioning of the CS492X will help to ensure reliable performance.

4.1 Decoupling

It is good practice to decouple noise from the power supply by placing capacitors directly between the power and ground of the CS492X. Each pair of power pins (VD1/DGND, VD2/DGND, VD3/DGND, VA/AGND) should have its own decoupling capacitors. The recommended procedure is to place both a 0.1uF

and a 1uF capacitor as close as physically possible to each power pin. The 0.1uF capacitor should be closest to the device (typically 5mm or closer).

4.2 Analog Power Conditioning

In order to obtain the best performance from the CS4923/4/5/6/7/8/9's internal PLL, the analog power supply (VA) must be as clean as possible. A ferrite bead should be used to filter the 3.3V power supply for the analog portion of the CS492X. This power scheme is shown in the typical connection diagrams.

4.3 Pads

Revision D and all subsequent revisions incorporate 5V tolerant pads. This means that while the CS492X power supplies require 3.3 volts, 5 volt signals can be applied to the inputs without damaging the part.

The I/O pads for Revision B of the CS4923/4/5/6 are not 5 volt tolerant. Input levels for revision B of the CS4923/4/5/6 should be no greater than 3.3

5. CLOCKING

Revision D of the CS4923/4/5/6/7/8/9 also incorporates a programmable phase locked loop (PLL) clock synthesizer. The PLL takes an input reference clock and produces all the internal clocks required to run the internal DSP and to provide master mode timing to the audio input/output peripherals. The clock manager also includes a 33-bit system time clock (STC) to support audio and video synchronization in broadcast applications.

The PLL can be internally bypassed by connecting the CLKSEL pin to VD. This connection multiplexes the CLKIN pin directly to the DSP clock. Care should be taken to note the minimum CLKIN requirements when bypassing the PLL.

The PLL reference clock has three possible sources that are routed through a multiplexer controlled by the DSP: SCLKN2, SCLKN1, and CLKIN. Typically, in audio/video environments like set-top boxes, the CLKIN pin is connected to 27 MHz. In other scenarios such as an A/V receiver design, the PLL can be clocked through the CLKIN pin with even multiples of the desired sampling rate or with an already available clock source. CLKIN is typically a multiple of a standard sampling frequency in this scenario (e.g. 11.2896 MHz).

The clock manager is controlled by the DSP application software. Please refer to the Hardware User's Guide for the CS4923/4/5/6/7/8/9 (AN115) and all relevant application code user's guides for information on supported CLKIN frequencies and how to set up and control the internal PLL.

6. CONTROL

Control of the CS4923/4/5/6/7/8/9 can be accomplished through one of four methods. The CS492X supports I²C and SPI serial communication. In addition the CS492X supports both a Motorola and Intel byte wide parallel host control mode. Only one of the four communication modes can be selected for control. The states of the \overline{RD} , \overline{WR} , and PSEL pins at the rising edge of \overline{RESET} determine the interface type as shown in table 2.

\overline{RD} (Pin 5)	\overline{WR} (Pin 4)	PSEL (Pin 19)	Host Interface Mode
1	1	1	8-bit Motorola
1	1	0	8-bit Intel
0	1	X	Serial I ² C
1	0	X	Serial SPI

Table 2. Host Modes

Whichever host communication mode is used, host control of the CS4923/4/5/6/7/8/9 is handled through the application software running on the DSP. Configuration and control of the CS492X decoder and its peripherals are indirectly executed through a messaging protocol supported by the downloaded application code. In other words successful communication can only be accomplished by following the low level hardware communication format and high level messaging protocol. The specifications of the messaging protocol can be found in any of the application code user's guides.

It should be noted that when using the CS4926 or CS4928 for DTS decoding, an external memory interface must be used for DTS tables that are required for decoding. (see section 6.5 for information on external memory). The external memory interface and the parallel interface modes can not be used together. For this reason the system designer must use one of the serial communication modes with external memory if designing with the

CS4926 or CS4928 for DTS decode. An image of the DTS tables is available from the factory.

Below is a brief discussion of each of the communication modes available for the CS4923/4/5/6/7/8/9. For a complete description of these communication modes along with flow charts, pseudocode and restrictions, please consult the CS4923/4/5/6/7/8/9 Hardware User's Guide. A complete understanding of the decoder and its operation can not be accomplished without consulting the CS4923/4/5/6/7/8/9 Hardware User's Guide and the application code user's guides.

6.1 Boot and Control Mode Overview

Regardless of which communication mode is used, the CS4923/4/5/6/7/8/9 must be booted and loaded with code at run time. The general sequence from a hardware perspective is as follows:

- 5) \overline{RESET} Low
- 6) Set Communication Configuration Pins
- 7) \overline{RESET} High
- 8) Download Code
- 9) Configure Hardware
- 10) Configure Application Code
- 11) Kickstart the Decoder

The host has three options for code download:

- Parallel Download through the parallel host interface
- Serial download through either the SPI or I²C interface
- Autoboot with external memory when using a serial communication mode.

Once again the CS4923/4/5/6/7/8/9 Hardware User's Guide should be consulted for a complete description of the boot and download procedure including the necessary communication handshaking. Hardware configuration is also

covered in the CS4923/4/5/6/7/8/9 Hardware User's Guide. Application configuration is described in the application code user's guide for the code being used.

6.2 Parallel Host Interface

The byte wide parallel host interface of the CS492X supports application code download, communication for hardware and application configuration, compressed data input, and PCM data input. When using either Intel or Motorola modes, the parallel interface is implemented using four 8-bit internal registers which are selectable using inputs A1 and A0 as shown in table 3. Table 5 shows the individual registers and their bit mapping.

In either the Intel or Motorola mode the $\overline{\text{INTREQ}}$ pin can be used to interrupt the host when the DSP has unsolicited outgoing messages to be read. For specific details on the behavior of $\overline{\text{INTREQ}}$ in one of the parallel modes, please see the CS4923/4/5/6/7/8/9 Hardware User's Guide.

A1 (Pin 6)	A0 (Pin 7)	Register Name	Register Function
1	1	CMPDATA	8-bit compressed data to input unit (write only)
1	0	PCMDATA	8-bit linear PCM data to input unit (write only)
0	1	CONTROL	Multi-bit control register for setup and handshaking (R/W)
0	0	HOSTMSG	8-bit control pipe message register (R/W)

Table 3. Host Memory Map

6.2.1 Intel Parallel Host Mode

Intel parallel host mode is accomplished with $\overline{\text{CS}}$, $\overline{\text{RD}}$, $\overline{\text{WR}}$, A[1:0], and DATA[7:0]. Table 4 shows the pin name, pin description and pin number of

each signal on the CS4923/4/5/6/7/8/9. $\overline{\text{RD}}$ and $\overline{\text{WR}}$ have no effect when $\overline{\text{CS}}$ is held high.

When the DSP writes a byte to the HOSTMSG register, the HOUTRDY bit in the CONTROL register is set to indicate that there is data to be read. To initiate a read cycle the host should drive $\overline{\text{CS}}$ low. When $\overline{\text{CS}}$ is low, $\overline{\text{RD}}$ becomes the output enable for DATA[7:0]. When $\overline{\text{CS}}$ and $\overline{\text{RD}}$ are low, the contents of register address A[1:0] are driven on the DATA[7:0] bus. The address A[1:0] must be valid a minimum time before either $\overline{\text{CS}}$ or $\overline{\text{RD}}$ goes low. The HOUTRDY bit of the CONTROL register is cleared after the host reads from the HOSTMSG register.

Driving both $\overline{\text{CS}}$ and $\overline{\text{WR}}$ low begins an 8-bit write cycle. The address A[1:0] must be valid a minimum time before either $\overline{\text{CS}}$ or $\overline{\text{WR}}$ goes low. On the first rising edge of $\overline{\text{CS}}$ or $\overline{\text{WR}}$, the write cycle ends and DATA[7:0] are latched internally by the CS492X. Data must be held sufficiently to satisfy the hold time as given in the timing section. The HINBSY bit is set when the host writes the HOSTMSG register. This bit is cleared when the byte in the HOSTMSG register is read by the DSP.

During $\overline{\text{RESET}}$ low, all control signals have no effect and DATA[7:0] are high impedance.

Pin Name	Pin Description	Pin Number
CS	Chip Select	18
RD	Output Enable	5
WR	Write Enable	4
A1	Register Address 1	6
A0	Register Address 0	7
INTREQ	Interrupt Request	20
DATA7	Data Bit 7	8
DATA6	Data Bit 6	9
DATA5	Data Bit 5	10
DATA4	Data Bit 4	11
DATA3	Data Bit 3	14
DATA2	Data Bit 2	15
DATA1	Data Bit 1	16
DATA0	Data Bit 0	17

Table 4. Intel Parallel Host Mode Pin Assignments

Host Message (HOSTMSG) Register, A[1:0] = 00b

7	6	5	4	3	2	1	0
HOSTMSG7	HOSTMSG6	HOSTMSG5	HOSTMSG4	HOSTMSG3	HOSTMSG2	HOSTMSG1	HOSTMSG0

HOSTMSG7–0 Host data to and from the DSP. A read or write of this register operates handshake bits between the internal DSP and the external host. This register typically passes multibyte messages carrying microcode, control, and configuration data. HOSTMSG is physically implemented as two independent registers for input and output. (Read and write)

Host Control (CONTROL) Register, A[1:0] = 01b

7	6	5	4	3	2	1	0
Reserved	CMPRST	PCMRST	MFC	MFB	HINBSY	HOUTRDY	Reserved

Reserved Always write a 0 for future compatibility.

CMPRST When set, initializes the CMPDATA compressed data input channel. Writing a one to this bit holds the port in reset. Writing zero enables the port. This bit must be low for normal operation. (Write only)

PCMRST When set, initializes the linear PCM input channel. This bit is toggled to indicate the first sample of the left channel for a PCM stream. Writing a one to this bit holds the port in reset. Writing zero enables the port. This bit must be low for normal operation. (Write only)

MFC When high, indicates that the PCMDATA input buffer is almost full. The input buffer threshold level is application code dependent. (Read only)

MFB When high, indicates that the CMPDATA input buffer is almost full. The input buffer threshold level is application code dependent. (Read only)

HINBSY Set when the host writes to HOSTMSG. Cleared when the DSP reads data from the HOSTMSG register. The host reads this bit to determine if the last host byte written has been read by the DSP. (Read only)

HOUTRDY Set when the DSP writes to the HOSTMSG register. Cleared when the host reads data from the HOSTMSG register. The DSP reads this bit to determine if the last DSP output byte has been read by the host. (Read only)

Reserved Always write a 0 for future compatibility.

PCM Data Input (PCMDATA) Register, A[1:0] = 10b

7	6	5	4	3	2	1	0
PCMDATA7	PCMDATA6	PCMDATA5	PCMDATA4	PCMDATA3	PCMDATA2	PCMDATA1	PCMDATA0

PCMDATA7–0 The host writes PCM data to the DSP input buffer at this address. (Write only)

Compressed Data Input (CMPDATA) Register, A[1:0] = 11b

7	6	5	4	3	2	1	0
CMPDATA7	CMPDATA6	CMPDATA5	CMPDATA4	CMPDATA3	CMPDATA2	CMPDATA1	CMPDATA0

CMPDATA7–0 The host writes compressed data to the DSP input buffer at this address. (Write only)

Table 5. Parallel Input/Output Registers

6.2.2 Motorola Parallel Host Mode

Motorola parallel host mode is accomplished with \overline{CS} , \overline{DS} , R/\overline{W} , $A[1:0]$, and $DATA[7:0]$. Table 6 shows the pin name, pin description and pin number of each signal on the CS4923/4/5/6/7/8/9. In Motorola host interface mode, the host interface pins act as an active-low chip select, \overline{CS} , an active-low data strobe, \overline{DS} , and a R/\overline{W} control signal. Internally to the CS492X, \overline{DS} and \overline{CS} are logically ANDED. Therefore, in some cases, \overline{DS} and \overline{CS} can be externally tied together with a common active-low strobe. Otherwise, in long decoder delay scenarios, read or write cycles can be terminated earlier by connecting the microprocessor active-low data-strobe signal to the CS492X \overline{DS} and a delayed final active-low chip select independently to the \overline{CS} pin.

When the DSP writes a byte to the HOSTMSG register, the HOUTRDY bit in the CONTROL register is set to indicate that there is data to be read. During read cycles, $DATA[7:0]$ are driven when R/\overline{W} is high and \overline{DS} and \overline{CS} are both low. $DATA[7:0]$ are released with the earliest of \overline{CS} or \overline{DS} going high. The HOUTRDY bit of the CONTROL register is cleared after the host reads from the HOSTMSG register.

Write cycles occur with R/\overline{W} low followed by \overline{DS} and \overline{CS} both going low. The $A[1:0]$ address pins select the specific address of the register to be written and $DATA[7:0]$ carry the data to be written. For write cycles, the first of \overline{CS} and \overline{DS} going high latches data. Data must be held sufficiently to satisfy the hold time as given in the timing section. The HINBSY is set when the host writes the HOSTMSG register. This bit is cleared when the byte in the HOSTMSG is internally read by the DSP.

Pin Name	Pin Description	Pin Number
CS	Chip Select	18
DS	Data Strobe	4
R/W	Read or Write Enable	5
A1	Register Address 1	6
A0	Register Address 0	7
INTREQ	Interrupt Request	20
DATA7	Data Bit 7	8
DATA6	Data Bit 6	9
DATA5	Data Bit 5	10
DATA4	Data Bit 4	11
DATA3	Data Bit 3	14
DATA2	Data Bit 2	15
DATA1	Data Bit 1	16
DATA0	Data Bit 0	17

Table 6. Motorola Parallel Host Mode Pin Assignments

6.3 SPI Serial Host Interface

For SPI communications, the CS4923/4/5/6/7/8/9 always acts as a slave. Serial SPI communication with the CS4923/4/5/6/7/8/9 is accomplished with 5 communication lines: \overline{CS} , SCCLK, SCDIN, SCDOOUT and \overline{INTREQ} . Table 7 shows the pin name, pin description and pin number of each signal on the CS4923/4/5/6/7/8/9. \overline{CS} is an active low chip select and must be held low for writes to and reads from the part. SCCLK is an input to the CS492X that clocks data in and out of the device on its rising edge. SCDIN is the data input and should be valid on the rising edge of SCCLK. SCDOOUT is the data output and will be valid on the rising edge of SCCLK. \overline{INTREQ} is an open drain, active-low interrupt request signal that is driven low by the CS492X when there is data to be read out.

Pin Name	Pin Description	Pin Number
CS	Chip Select	18
SCDIN	Serial Data Input	6
SCCLK	Serial Control Clock	7
SCDOOUT	Serial Data Output	19
INTREQ	Interrupt Request	20

Table 7. SPI Serial Mode Pin Assignments

6.3.1 SPI Write

When writing to the device in SPI, the same protocol can be used for sending a byte, a word or an entire download image as long as transfers occur on byte boundaries. Figure 19 illustrates the relative timing necessary for a three byte transfer to the CS492X. The host initiates an SPI write by driving CS low, followed by a 7-bit address and the read/write bit set low to indicate a write. The CS4923/4/5/6/7/8/9 internal 7-bit address is initially assigned to 000 0000b following a reset. The 7-bit address sent to the CS492X must match its internal address or the incoming data will be ignored. Address checking can be changed (either disabled or an actual address change) if desired. Address checking configuration is documented in the hardware configuration section of the CS4923/4/5/6/7/8/9 Hardware User's guide.

Data should be shifted into the CS492X most significant bit first with data being valid at the rising edge of SCCLK. It should be noted that data is internally transferred to the DSP on the falling edge of the eighth SCCLK after the eighth data bit of a byte. For this reason SCCLK must transition from high to low on the last bit of each byte or a loss of data will occur. If this final transfer of SCCLK does not occur the final byte will be lost and successful communication will not be possible.

6.3.2 SPI Read

The CS4923/4/5/6/7/8/9 will always indicate that it has data to be read by asserting the $\overline{\text{INTREQ}}$ line low. The host must recognize the request and start a read transaction with the CS492X. The same protocol will be used whether reading a byte or multiple bytes. Figure 19 also illustrates the relative timing of a three byte SPI read.

The host initiates an SPI read by driving $\overline{\text{CS}}$ low, followed by a 7-bit address and the read/write bit set high to indicate a read. The CS492X internal 7-bit address is initially assigned to 000 0000b following a reset. The 7-bit address sent to the CS492X must match its internal address or the incoming data will be ignored. Address checking can be disabled or the actual address can be changed if desired. Address checking configuration is documented in the hardware configuration section of the CS4923/4/5/6/7/8/9 Hardware User's guide.

After the address byte the host should clock data out of the device one byte at a time until $\overline{\text{INTREQ}}$ is no longer low. The host shifts data using the rising edge of SCCLK. The data is valid on the rising edge of SCCLK and transitions occur on the falling edge. In SPI mode, the $\overline{\text{INTREQ}}$ pin is deasserted immediately following the rising edge of the second-to-last data bit of the current byte being transferred if there is no more data to be read. The $\overline{\text{INTREQ}}$ pin is guaranteed to stay deasserted (high) until the rising edge of SCCLK for the last data bit.

If there is more data to be read from the DSP before the rising edge of SCCLK for the second-to-last data bit, then $\overline{\text{INTREQ}}$ remains asserted low. Immediately following the falling edge of SCCLK for the last data bit of the current byte, the next data byte loads into the internal serial shift register. The host should continue to read this new byte. It is important to note that once the data is in the shift register, clocks on the SCCLK line shift the data bits out of the shift register as long as $\overline{\text{CS}}$ is low.

For a thorough look at SPI communication and critical additional comments on $\overline{\text{INTREQ}}$ behavior reference the CS4923/4/5/6/7/8/9 Hardware User's Guide.

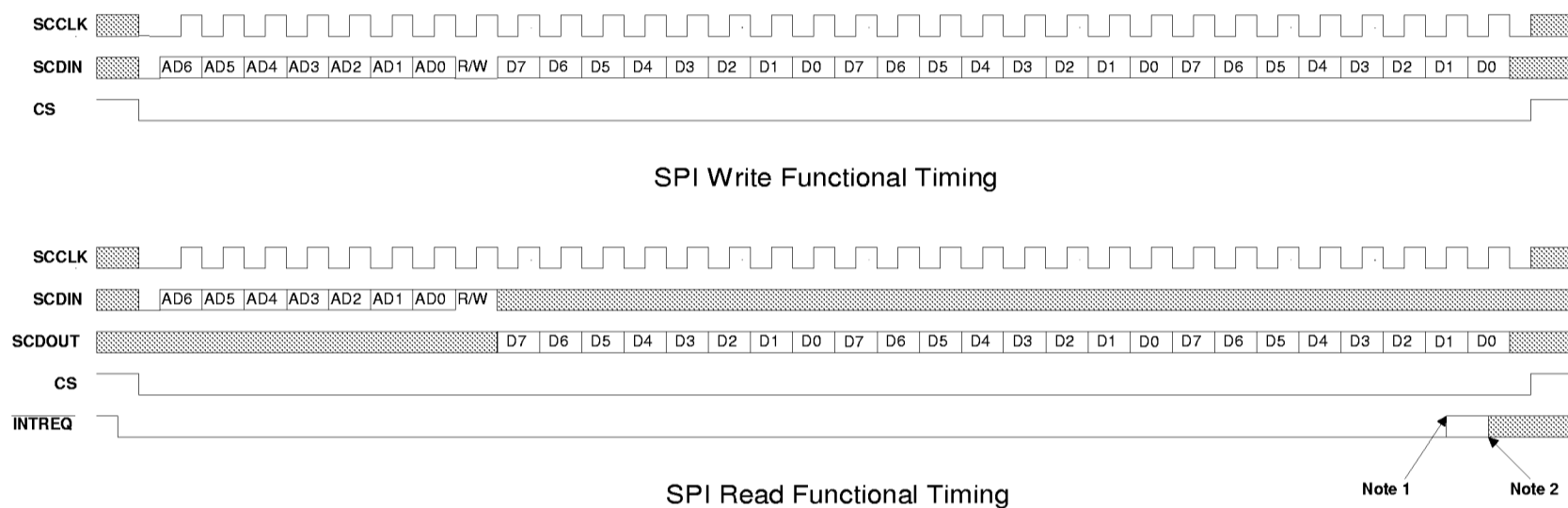

- Notes: 1. $\overline{\text{INTREQ}}$ is guaranteed to stay low until the rising edge of SCCLK for the second to last bit of the last byte to be transferred out of the CS4923/4/5/6/7/8/9
2. $\overline{\text{INTREQ}}$ is guaranteed to stay high until the next rising edge of SCCLK at which point it may go low again if there is new data to be read. The condition of $\overline{\text{INTREQ}}$ going low at this point should be treated as a new read condition and a new start condition followed by an address byte should be sent

Figure 19. SPI Timing

6.4 I²C Serial Host Interface

For I²C communications the CS4923/4/5/6/7/8/9 always acts as a slave. Serial I²C communication with the CS4923/4/5/6/7/8/9 is accomplished with 3 communication lines: SCCLK, SCDIO and $\overline{\text{INTREQ}}$. Table 8 shows the mnemonic, pin name, and pin number of each signal on the CS4923/4/5/6/7/8/9. SCCLK is an input to the CS492X that clocks data in and out of the device on its rising edge. It should be noted that the timing specifications for SCCLK are more stringent than certain I²C requirements so care should be taken that the rise and fall specifications for SCCLK are met as stated in the timing portion of this data sheet. SCDIO is a bidirectional data line whose data must be valid on the rising edge of SCCLK. $\overline{\text{INTREQ}}$ is an open drain, active-low request signal that is driven low by the CS492X when there is data to be read out.

Pin Name	Pin Description	Pin Number
SCCLK	Serial Control Clock	7
SCDIO	Serial Data Input and Output	19
INTREQ	Interrupt Request	20

Table 8. I²C Serial Mode Pin Assignments

6.4.1 I²C Write

When writing to the device in I²C, the same protocol can be used for sending a byte, a word or an entire download image as long as transfers occur on byte boundaries. Figure 20 illustrates the relative timing necessary for a three byte transfer to the CS492X. The host initiates a transfer with an I²C start condition followed by a 7-bit address and the read/write bit set low to indicate a write. The start condition is defined as the SCDIO falling with SCCLK held high. The CS492X internal 7-bit address is initially assigned to 000 0000b following a reset. The 7-bit address sent to the CS492X must match its internal address or the incoming data will be ignored. Address checking can be disabled or

the actual address can be changed if desired. Address checking configuration is documented in the hardware configuration section of the CS4923/4/5/6/7/8/9 Hardware User's guide. After the address byte the host should then clock an acknowledge ($\overline{\text{ACK}}$) from the part. During a write, an $\overline{\text{ACK}}$ is defined as SCDIO being driven low by the CS492X for one SCCLK period after each byte.

Data should be shifted into the CS492X most significant byte first with data being valid at the rising edge of SCCLK. The host should then clock out the acknowledge ($\overline{\text{ACK}}$ bit) bit from the CS492X. After the last byte to be sent is acknowledged, the host should send an I²C stop condition, which is defined as the rising edge of SCDIO while SCCLK is held high.

If the CS492X fails to acknowledge a byte, the host should re-transmit the same byte. If the CS492X does not acknowledge back to back bytes, then the host should reset the part.

6.4.2 I²C Read

The CS4923/4/5/6/7/8/9 will always indicate that it has data to be read by asserting the $\overline{\text{INTREQ}}$ line low. The host must recognize the request and start a read transaction with the CS492X. The same protocol will be used whether reading a byte or multiple bytes. Figure 20 also illustrates the relative timing of a three byte I²C read.

The host initiates a read with an I²C start condition followed by a 7-bit address and the read/write bit set high for a read. The start condition is defined as the SCDIO falling with SCCLK held high. The CS492X internal 7-bit address is initially assigned to 000 0000b following a reset. The 7-bit address sent to the CS492X must match its internal address or the incoming data will be ignored. Address checking can be disabled or the actual address can be changed if desired. Address checking configuration is documented in the hardware configuration section of the CS4923/4/5/6/7/8/9 Hardware User's guide.

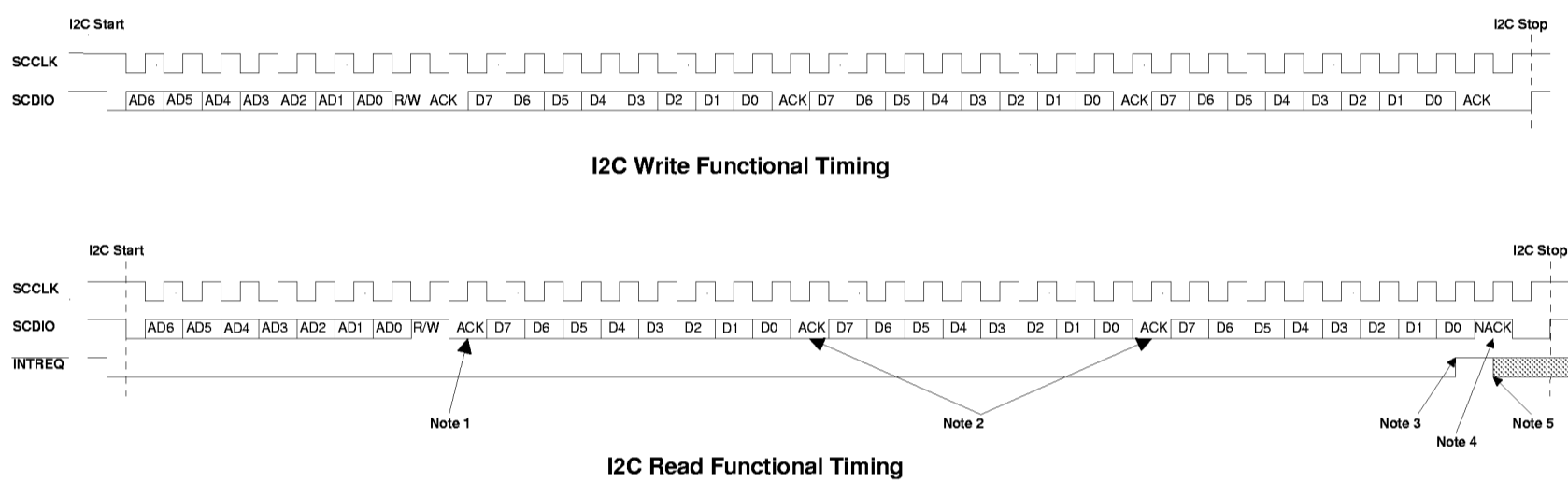

- Notes:
1. The $\overline{\text{ACK}}$ for the address byte is driven by the CS4923/4/5/6/7/8/9.
 2. The $\overline{\text{ACK}}$ s for the data bytes being read from the CS4923/4/5/6/7/8/9 should be driven by the host.
 3. $\overline{\text{INTREQ}}$ is guaranteed to stay low until the rising edge of SCCLK for last bit of the last byte to be transferred out of the CS4923/4/5/6/7/8/9
 4. A NOACK should be sent by the host after the last byte read to indicate the end of the read cycle.
 5. $\overline{\text{INTREQ}}$ is guaranteed to stay high until the next rising edge of SCCLK (for the $\overline{\text{ACK/NACK}}$ bit) at which point it may go low again if there is new data to be read. The condition of $\overline{\text{INTREQ}}$ going low at this point should be treated as a new read condition and a new start condition followed by an address byte should be sent.

Figure 20. I²C Timing

Following the address byte the host must clock out an acknowledge from the part.

After the address byte, the host should clock out data from the device one byte at a time until $\overline{\text{INTREQ}}$ is no longer low. The host shifts data using the rising edge of SCCLK. The data is valid on the rising edge of SCCLK and transitions on the falling edge. After each byte the host must send an acknowledge ($\overline{\text{ACK}}$) to the CS492X. While reading from the CS492X, an acknowledge is defined as SCDIO being driven low by the host for one SCCLK period after each byte. In I²C mode, the $\overline{\text{INTREQ}}$ pin is deasserted immediately following the rising edge of the last data bit of the current byte being transferred if there is no more data to be read. The $\overline{\text{INTREQ}}$ pin is guaranteed to stay deasserted (high) until the rising edge of SCCLK for the acknowledge bit.

For a more thorough look at I²C communication and critical additional information on $\overline{\text{INTREQ}}$ behavior reference the CS4923/4/5/6/7/8/9 Hardware User's Guide.

6.5 External Memory

If using one of the serial modes, i.e. SPI or I²C, the system designer has the option of using external memory. The external memory interface is not compatible with the parallel modes since there are shared pins that are needed by each mode. If using the CS4926 or CS4928 for DTS decode, external memory is required for external DTS tables.

The external memory interface was designed primarily for two purposes: 1) Autoboot and/or 2) real time external data access. The hardware implementation for either mode can be the same but the ROM access time requirements may differ. The CS4923/4/5/6/7/8/9 Hardware User's Guide should be referenced for more information including memory paging options to support both autoboot and real time access as well as ROM speed requirements.

The external memory interface is implemented on the CS4923/4/5/6/7/8/9 with the following signals: EMAD[7:0], $\overline{\text{EXTMEM}}$ and $\overline{\text{EMOE}}$. Table 9 shows the pin name, pin description and pin number of each signal on the CS4923/4/5/6/7/8/9. EMAD[7:0] serve as a multiplexed address and data bus. $\overline{\text{EMOE}}$ is an active-low external-memory data output enable as well as the address latch strobe. $\overline{\text{EXTMEM}}$ serves as the active low chip select output. Figure 21 illustrates one possible external memory architecture for the CS4923/4/5/6/7/8/9. Figure 22 shows the functional timing of a run-time memory access .

Pin Name	Pin Description	Pin Number
$\overline{\text{EMOE}}$	* External Memory Output Enable & Address Latch Strobe	5
$\overline{\text{EMWR}}$	* External Memory Write Strobe	4
$\overline{\text{EXTMEM}}$	External Memory Select	21
EMAD7	Address and Data Bit 7	8
EMAD6	Address and Data Bit 6	9
EMAD5	Address and Data Bit 5	10
EMAD4	Address and Data Bit 4	11
EMAD3	Address and Data Bit 3	14
EMAD2	Address and Data Bit 2	15
EMAD1	Address and Data Bit 1	16
EMAD0	Address and Data Bit 0	17

* - These pins must be configured appropriately to select a serial host communication mode for the CS4923/4/5/6/7/8/9 at the rising edge of $\overline{\text{RESET}}$

Table 9. Memory Interface Pins

The external memory address is capable of addressing between 64 kilobytes and 16 megabytes through a 16 to 24 bit addressing scheme. The address comes from the DSP writing two or three initial bytes of address consecutively on EMAD[7:0]. Each byte of address is externally latched with the rising edge of $\overline{\text{EMOE}}$ while $\overline{\text{EXTMEM}}$ is high. After the 2 or 3-byte address is latched externally, the CS4923/4/5/6/7/8/9 then drives $\overline{\text{EXTMEM}}$ and $\overline{\text{EMOE}}$ low simultaneously to select the external memory. During this time the data is read by the CS492X.

Although the memory can use more address bits, typically only 16 bits of address space are used. For this reason the memory example shown incorporates a 2 latch memory architecture.

The two latch external memory architecture is required for the CS4926 or CS4928 when using DTS. A three latch architecture can not be used with the CS4926 or CS4928 running DTS since the run time memory access uses only 2 address cycles.

6.5.1 External Memory and Autboot

To configure the CS4923/4/5/6/7/8/9 to automatically load its code from external memory, the $\overline{\text{ABOOT}}$ signal should be driven low at the rising edge of $\overline{\text{RESET}}$. Once again this mode can only be chosen if either SPI or I²C serial communication is being used. In serial control port mode, holding the $\overline{\text{ABOOT}}$ pin low as the CS492X leaves the reset state enables an automatic boot.

$\overline{\text{ABOOT}}$ can be released following the rising edge of $\overline{\text{RESET}}$. During the automatic boot cycle, the serial control port should remain idle. Figure 23 shows an autboot functional timing example.

The autboot cycle actually is a 24 bit, or three address byte cycle. It should be noted that for autboot, the most significant byte is always zero. For this reason a two latch external memory configuration can be used for autboot. The higher order address byte simply shifts out of the memory latch and is discarded. If desired, a three latch interface could also be used with the CS4923/4/5/7/9 but it is not necessary.

For more information about autboot and for a thorough description of different external memory architectures, reference the CS4923/4/5/6/7/8/9 Hardware User's Guide.

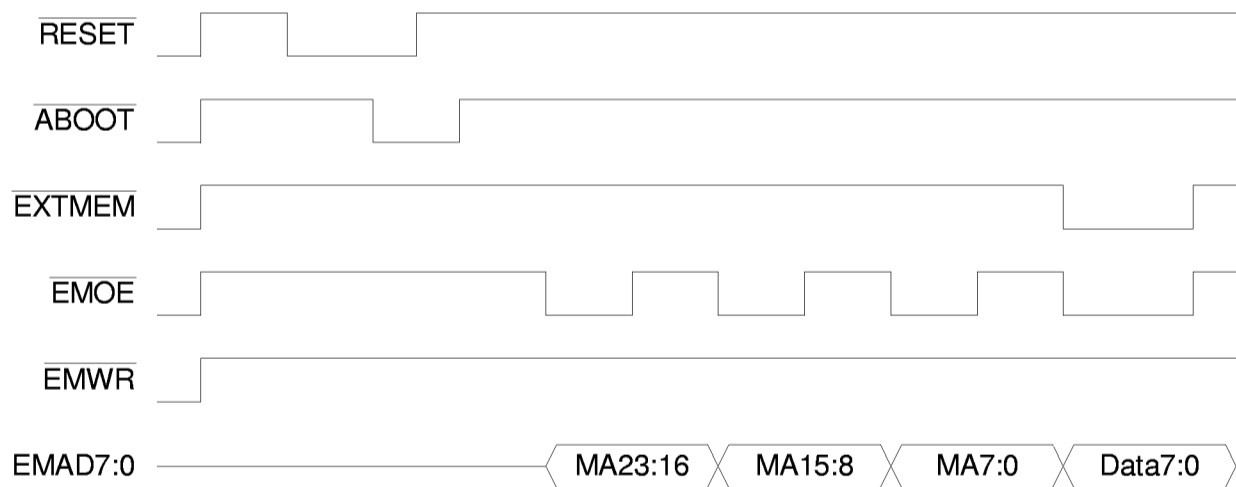

Figure 23. Autboot Timing Diagram

7. DIGITAL INPUT & OUTPUT

The CS4923/4/5/6/7/8/9 supports a wide variety of data input and output mechanisms through various input and output ports. Hardware availability is entirely dependent on whether the software application code being used supports the required mode. This data sheet presents most of the modes available with the CS4923/4/5/6/7/8/9 hardware. This does not mean that all of the modes are available with any particular piece of application code. Both the CS4923/4/5/6/7/8/9 Hardware User's Guide and the application code user's guide for the particular code being used should be referenced to determine if a particular mode is supported.

7.1 Digital Audio Formats

This subsection will describe some common audio formats that the CS4923/4/5/6/7/8/9 supports. It should be noted that the input ports use up to 24-bit PCM resolution and 16-bit compressed data word lengths. The output port of the CS492X provides up to 20-bit PCM resolution.

I²S: Figure 24 shows the I²S format. For I²S, data is presented most significant bit first, one SCLK delay after the transition of LRCLK and is valid on the rising edge of SCLK. For the I²S format, the left subframe is presented when LRCLK is low and the right subframe is presented when LRCLK is high. SCLK is required to run at a frequency of 48Fs or greater on the input ports.

Left Justified: Figure 25 shows the left justified format with a rising edge SCCLK. Data is

presented most significant bit first on the first SCLK after an LRCLK transition and is valid on the rising edge of SCLK. For the left justified format, the left subframe is presented when LRCLK is high and the right subframe is presented when LRCLK is low. The left justified format can also be programmed for data to be valid on the falling edge of SCLK. SCLK is required to run at a frequency of 48Fs or greater on the input ports.

Right Justified: Figure 26 shows the right justified format. The right justified format is similar to the left justified format except the least significant bit is right justified to be valid on the last transition of SCLK before an LRCLK transition. Data is still presented most significant bit first. For the right justified format, the left subframe is presented when LRCLK is high and the right subframe is presented when LRCLK is low. The right justified format can also be programmed for data being valid on the falling edge of SCLK. SCLK is required to run at a frequency of 48Fs or greater on the input ports.

Multi-Channel: Figure 27 shows the multi-channel format. In this format up to 6 channels of audio are presented on one data line with 20 bits per channel. Channels 0, 2, and 4 are presented while the LR-CLK is high and channels 1, 3, 5 are presented while the LRCLK is low. Data is valid on the rising edge of SCLK and is presented most significant bit first.

Because each of the ports is fully configurable, there may be modes that can be supported which are not presented.

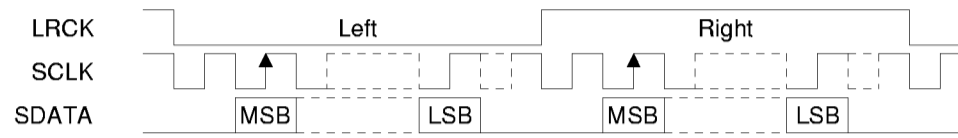

Figure 24. I²S Format

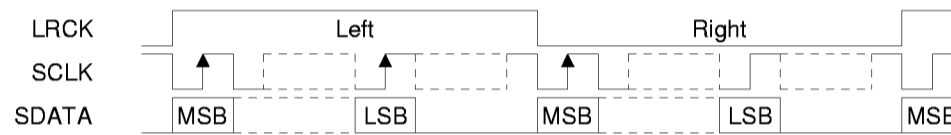

Figure 25. Left Justified Format

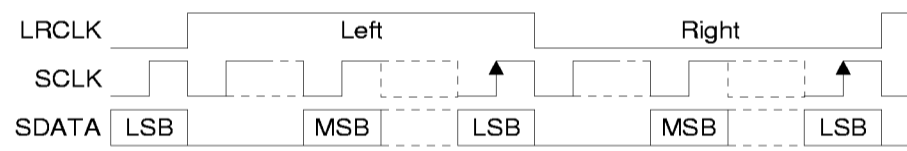

Figure 26. Right Justified

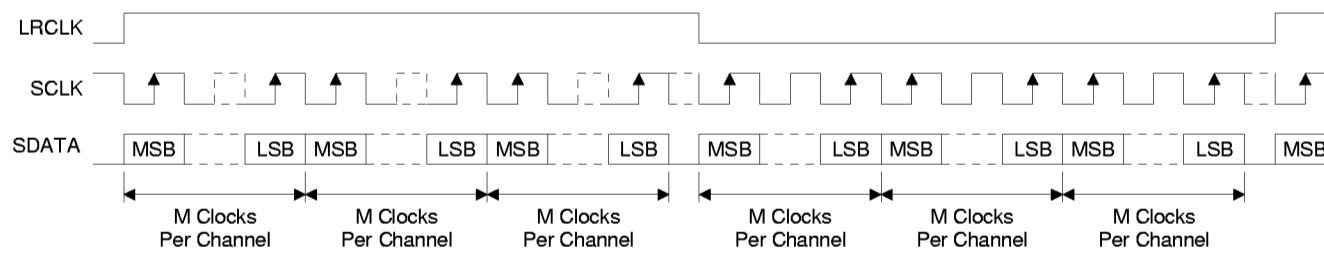

Figure 27. Multi-Channel Format (M == 20)

7.2 Digital Audio Input Port

The digital audio input port, or DAI, is used for both compressed and PCM digital audio data input. In addition this port supports a special clocking mode in which a clock can be input to directly drive the internal 33 bit counter. Table 10 shows the pin names, mnemonics and pin numbers associated with the DAI.

Pin Name	Pin Description	Pin Number
SDATAN1	Serial Data In	22
SCLKN1	Serial Bit Clock	25
LRCLKN1	Frame Clock	26

Table 10. Digital Audio Input Port

The DAI can be programmed to support I²S, left justified and right justified data input. In addition the DAI can be programmed for slave clocks, where LRCLKN1 and SCLKN1 are inputs, or master clocks, where LRCLKN1 and SCLKN1 are outputs. In order for clocks to be master, the internal PLL must be used.

STCCLK2 can also be programmed to drive the internal 33 bit counter. This counter would typically be driven by a 90kHz clock. The internal counter is used by certain application code for audio/video synchronization purposes.

7.3 Compressed Data Input Port

The compressed data input port, or CDI, can be used for both compressed and PCM data input. Table 11 shows the mnemonic, pin name and pin number of the pins associated with the CDI port on the CS4923/4/5/6/7/8/9.

Pin Name	Pin Description	Pin Number
SDATAN2	Serial Data In	27
CMPDATA	Compressed Data In	
SCLKN2	Serial Bit Clock	28
CMPCLK		
LRCLKN2	Frame Clock	29
CMPREQ	Data Request Out	

Table 11. Compressed Data Input Port

The CDI can be configured to support I²S, left justified and right justified formats. The CDI can also be programmed for slave clocks, where LRCLKN2 and SCLKN2 are inputs, or master clocks, where LRCLKN2 and SCLKN2 are outputs. In order for clocks to be mastered, the internal PLL must be used.

In addition the CDI can be configured for bursty compressed data input. Bursty audio delivery is a special format in which only clock (CMPCLK) and data (CMPDAT) are used to deliver compressed data to the CS4923/4/5/6/7/8/9 (i.e. no frame clock or LRCLK). A third line, $\overline{\text{CMPREQ}}$, is used to request more data from the host. It is an indicator that the CS492X internal FIFO is low on data and can accept another burst. Typically this mode is used for compressed data delivery where asynchronous data transfer occurs in the system, i.e. in a system such as a set-top box or HDTV. PCM data can not be presented in this mode since data is interpreted as a continuous stream with no word boundaries.

7.4 Parallel Digital Audio Data Input

If using the Intel or Motorola Parallel host interface mode, the system designer can also choose to deliver data through the byte wide parallel port. The compressed data input register receives bytes of data when the host interface writes to address 11b (A1 and A0 are both high). The host interface port also utilizes the $\overline{\text{CMPREQ}}$ pin and the MFB and MFC flags in the CONTROL register, which are configurable to supply a data request flag at different input buffer thresholds. $\overline{\text{CMPREQ}}$ acts as an almost full flag. The CS4923/4/5/6/7/8/9 can safely receive different size blocks of data depending on the level of the input buffer threshold. The threshold level is programmable and the default level may differ between applications. This mode reduces the polling burden associated with hand-feeding the compressed data.

In parallel host mode, the CS4923/4/5/6/7/8/9 can accept PCM data written through the byte-wide host interface to address 10b (A1 high, A0 low). In this mode, there is a close connection between the CS4923/4/5/6/7/8/9 application code and the host processor that is delivering the PCM data. The PCMRST bit of the CONTROL register provides absolute software/hardware synchronization by initializing the input channel to uniquely recognize the first write to the byte-wide PCMDATA port. Toggling PCMRST high and low informs the DSP that the next sample read from the PCMDATA port is the first sample of the left channel. In this fashion, the CS492X can translate successive byte writes into a variable number of channels with a variable PCM sample size. In the most simple case, the CS492X can receive stereo 8-bit PCM one byte at a time with the internal DSP assigning the first 8-bit write (after PCMRST) to the left channel and the second 8-bit write to the right channel. For 16-bit PCM, it assigns the first two 8-bit writes (after PCMRST) to the left channel and the next two writes to the right channel.

7.5 Digital Audio Output Port

The Digital Audio Output port, or DAO, is the port used for digital output from the DSP. Table 12 shows the signals associated with the DAO. As there are many modes that are firmware configurable on the DAO, please consult the Hardware User's Guide and the application code user's guides to determine which modes are supported by the download code being used.

Pin Name	Pin Description	Pin Number
AUDAT2	Serial Data In	39
AUDAT1	Serial Data In	40
AUDAT0	Serial Data In	41
LRCLK	Frame Clock	42
SCLK	Serial Bit Clock	43
MCLK	Master Clock	44
XMT958	IEC60958 Transmitter	3

Table 12. Digital Audio Output Port

MCLK is the master clock and is firmware configurable to be either an input or an output. If MCLK is to be used as an output, the internal PLL must be used. As an output MCLK can be configured to provide a 128Fs, 256Fs or 512Fs clock, where Fs is the output sample rate.

SCLK is the bit clock used to clock data out on AUDATA0, AUDATA1 and AUDATA2. LRCLK is the data framing clock whose frequency is typically equal to the sampling frequency. Both LRCLK and SCLK can be configured as either inputs (Slave mode) or outputs (Master mode). When LRCLK and SCLK are configured as inputs, MCLK is a don't care as an input. When LRCLK and SCLK are configured as outputs, they are derived from MCLK. Whether MCLK is configured as an input or an output, an internal divider from the MCLK signal is used to produce LRCLK and SCLK. The ratios shown in table 13 give the possible SCLK values for different MCLK frequencies (all values in terms of the sampling frequency, Fs).

MCLK (Fs)	SCLK (Fs)					
	32	48	64	128	256	512
128	X		X			
384**	X	X	X			
256	X		X	X	X	
512	X		X	X	X	X

** For MCLK as an input only

Table 13. MCLK/SCLK Master Mode Ratios

AUDAT0 is configurable to provide six, four, or two channels. AUDAT1 and AUDAT2 can both output two channels of data. Typically all three AUDAT outputs are used in left justified, I2S or right justified modes. In this way all six channels of surround (Left, Center, Right, Left Surround, Right Surround and Subwoofer) are provided. Alternatively the multi-channel mode can be configured to provide single data line multi-channel support. Please consult the Hardware User's Guide and the application code user's



guides to determine which modes are supported by the download code being used.

Serial digital audio data bit placement and sample alignment is fully configurable in the CS4923/4/5/6/7/8/9 including left justified, right justified, delay bits or no delay bits, variable sample word sizes, variable output channel count, and programmable output channel pin assignments and clock edge polarity to integrate with most digital audio interfaces. If a mode is needed which is not supported, please consult your Crystal Representative as to its availability.

7.5.1 IEC60958 Output

The XMT958 output provides a CMOS level bi phase encoded output. The XMT958 function can be internally clocked from the PLL or from an MCLK input if MCLK is 256Fs or 512Fs. All channel status information can be used when using software which supports this functionality. This output can be used for either 2 channel PCM output or compressed data output in accordance with IEC61937. To be fully IEC60958 compliant this output would need to be buffered through an RS422 device or an optocoupler as its outputs are only CMOS. Please consult the CS4923/4/5/6/7/8/9 Hardware User's Guide and an application code user's guide to determine if this pin is supported by the download code being used.

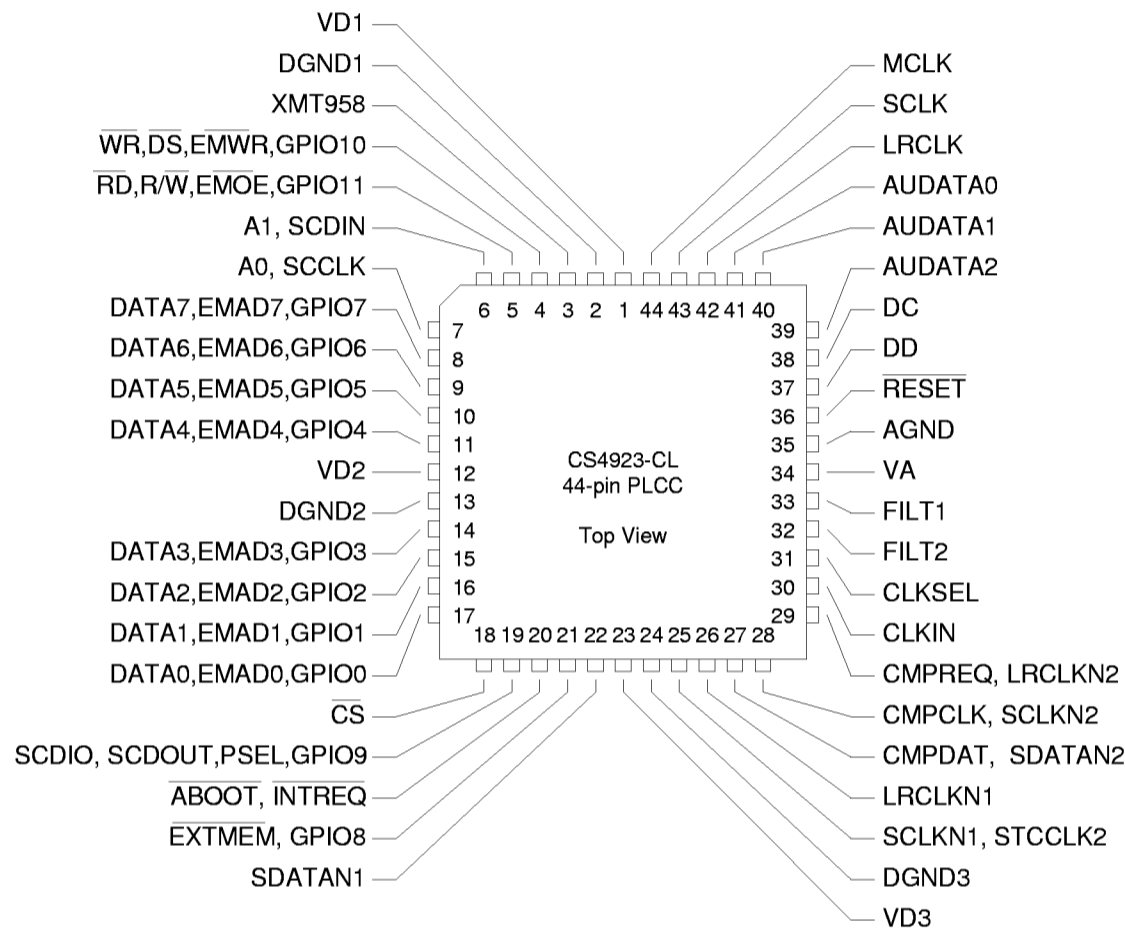
8. PIN DESCRIPTIONS

VA—Analog Positive Supply: Pin 34

Analog positive supply for clock generator. Nominally +3.3 V.

AGND—Analog Supply Ground: Pin 35

Analog ground for clock generator PLL.

VD1, VD2, VD3—Digital Positive Supply: Pins 1, 12, 23

Digital positive supplies. Nominally +3.3 V.

DGND1, DGND2, DGND3—Digital Supply Ground: Pins 2, 13, 24

Digital ground.

FILT1—Phase-Locked Loop Filter: Pin 33

Connects to an external filter for the on-chip phase-locked loop. This pin does not meet Cirrus Logic's ESD tolerance of 2000 V using the human body model. This pin will tolerate ESD of 1000 V using the human body model.

**FILT2—Phase Locked Loop Filter: Pin 32**

Connects to an external filter for the on-chip phase-locked loop. This pin does not meet Cirrus Logic's ESD tolerance of 2000 V using the human body model. This pin will tolerate ESD of 1000 V using the human body model.

CLKIN—Master Clock Input: Pin 30

CS4923/4/5/6/7/8/9 clock input. When in internal clock mode (CLKSEL == DGND), this input is connected to the internal PLL from which all internal clocks are derived. When in external clock mode (CLKSEL == VD), this input is connected to the DSP clock. *INPUT*

CLKSEL—DSP Clock Select: Pin 31

This pin selects the clock mode of the CS4923/4/5/6/7/8/9. When CLKSEL is low, CLKIN is connected to the internal PLL from which all internal clocks are derived. When CLKSEL is high CLKIN is connected to the DSP clock. *INPUT*

DATA7, EMAD7, GPIO7—Pin 8**DATA6, EMAD6, GPIO6—Pin 9****DATA5, EMAD5, GPIO5—Pin 10****DATA4, EMAD4, GPIO4—Pin 11****DATA3, EMAD3, GPIO3—Pin 14****DATA2, EMAD2, GPIO2—Pin 15****DATA1, EMAD1, GPIO1—Pin 16****DATA0, EMAD0, GPIO0—Pin 17**

In parallel host mode, these pins provide a bidirectional data bus. If a serial host mode is selected, these pins can provide a multiplexed address and data bus for connecting an 8-bit external memory. Otherwise, in serial host mode, these pins can act as general-purpose input or output pins that can be individually configured and controlled by the DSP.

BIDIRECTIONAL - Default: INPUT

A0, SCCLK—Host Parallel Address Bit Zero or Serial Control Port Clock: Pin 7

In parallel host mode, this pin serves as one of two address input pins used to select one of four parallel registers. In serial host mode, this pin serves as the serial control clock signal, specifically as the SPI clock input or the I²C clock input. *INPUT*

A1, SCDIN—Host Parallel Address Bit One or SPI Serial Control Data Input: Pin 6

In parallel host mode, this pin serves as one of two address input pins used to select one of four parallel registers. In SPI serial host mode, this pin serves as the data input. *INPUT*

 $\overline{\text{RD}}$, $\overline{\text{R/W}}$, $\overline{\text{EMOE}}$, GPIO11—Host Parallel Output Enable or Host Parallel $\overline{\text{R/W}}$ or External Memory Output Enable or General Purpose Input & Output Number 11: Pin 5

In Intel parallel host mode, this pin serves as the active-low data bus enable input. In Motorola parallel host mode, this pin serves as the read-high/write-low control input signal. In serial host mode, this pin can serve as the external memory active-low data-enable output signal. Also in serial host mode, this pin can serve as a general purpose input or output bit.

BIDIRECTIONAL - Default: INPUT

 $\overline{\text{WR}}$, $\overline{\text{DS}}$, $\overline{\text{EMWR}}$, $\overline{\text{GPIO10}}$ —Host Write Strobe or Host Data Strobe or External Memory Write Enable or General Purpose Input & Output Number 10: Pin 4

In Intel parallel host mode, this pin serves as the active-low data-write-input strobe. In Motorola parallel host mode, this pin serves as the active-low data-strobe-input signal. In serial host mode, this pin can serve as the external-memory active-low write-enable output signal. Also in serial host mode, this pin can serve as a general purpose input or output bit. *BIDIRECTIONAL - Default: INPUT*

 $\overline{\text{CS}}$ —Host Parallel Chip Select, Host Serial SPI Chip Select: Pin 18

In parallel host mode, this pin serves as the active-low chip-select input signal. In serial host SPI mode, this pin is used as the active-low chip-select input signal. *INPUT*

 $\overline{\text{RESET}}$ —Master Reset Input: Pin 36

Asynchronous active-low master reset input. Reset should be low at power-up to initialize the CS4923/4/5/6/7/8/9 and to guarantee that the device is not active during initial power-on stabilization periods. At the rising edge of reset the host interface mode is selected contingent on the state of the $\overline{\text{RD}}$, $\overline{\text{WR}}$ and $\overline{\text{PSEL}}$ pins. Additionally, an autoboot sequence can be initiated if a serial control mode is selected and $\overline{\text{ABOOT}}$ is held low. If reset is low all bidirectional pins are high impedance inputs. *INPUT*

 $\overline{\text{SCDIO}}$, $\overline{\text{SCDOUT}}$, $\overline{\text{PSEL}}$, $\overline{\text{GPIO9}}$ —Serial Control Port Data Input and Output, Parallel Port Type Select: Pin 19

In $\overline{\text{I}^2\text{C}}$ mode, this pin serves as the open-drain bidirectional data pin. In SPI mode this pin serves as the data output pin. In parallel host mode, this pin is sampled at the rising edge of $\overline{\text{RESET}}$ to configure the parallel host mode as an Intel type bus or as a Motorola type bus. In parallel host mode, after the bus mode has been selected, the pin can function as a general-purpose input or output pin. *BIDIRECTIONAL - Default: INPUT*
In $\overline{\text{I}^2\text{C}}$ mode this pin is an OPEN.DRAIN.I/O and requires a 4.7k Pull-Up

 $\overline{\text{EXTMEM}}$, $\overline{\text{GPIO8}}$ —External Memory Chip Select or General Purpose Input & Output Number 8: Pin 21

In serial control port mode, this pin can serve as an output to provide the chip-select for an external byte-wide ROM. In parallel and serial host mode, this pin can also function as a general-purpose input or output pin. *BIDIRECTIONAL - Default: INPUT*

 $\overline{\text{INTREQ}}$, $\overline{\text{ABOOT}}$ —Control Port Interrupt Request, Automatic Boot Enable: Pin 20

Open-drain interrupt-request output. This pin is driven low to indicate that the DSP has outgoing control data and should be serviced by the host. Also in serial host mode, this signal initiates an automatic boot cycle from external memory if it is held low through the rising edge of reset. *OPEN.DRAIN.I/O - Requires 4.7k Ohm Pull-Up*

 $\overline{\text{AUDATA2}}$ —Digital Audio Output 2: Pin 39

PCM multi-format digital-audio data output, capable of two-channel 20-bit output. This PCM output defaults to DGND as output until enabled by the DSP software. *OUTPUT*

**AUDATA1—Digital Audio Output 1: Pin 40**

PCM multi-format digital-audio data output, capable of two-channel 20-bit output. This PCM output defaults to DGND as output until enabled by the DSP software. *OUTPUT.*

AUDATA0—Digital Audio Output 0: Pin 41

PCM multi-format digital-audio data output, capable of two-, four-, or six-channel 20-bit output. This PCM output defaults to DGND as output until enabled by the DSP software. *OUTPUT.*

MCLK—Audio Master Clock: Pin 44

Bidirectional master audio clock. MCLK can be an output from the CS4923/4/5/6/7/8/9 that provides an oversampled audio-output clock at either 128 Fs, 256 Fs, or 512 Fs. MCLK can be an input at 128 Fs, 256 Fs, 384 Fs, or 512 Fs. MCLK is used to derive SCLK and LRCLK when SCLK and LRCLK are driven by the CS492X. *BIDIRECTIONAL - Default: INPUT.*

SCLK—Audio Output Bit Clock: Pin 43

Bidirectional digital-audio output bit clock. SCLK can be an output that is derived from MCLK to provide 32 Fs, 64 Fs, 128 Fs, 256 Fs, or 512 Fs, depending on the MCLK rate and the digital-output configuration. SCLK can also be an input and must be at least 48Fs or greater. As an input, SCLK is independent of MCLK. *BIDIRECTIONAL - Default: INPUT.*

LRCLK—Audio Output Sample Rate Clock: Pin 42

Bidirectional digital-audio output-sample-rate clock. LRCLK can be an output that is divided from MCLK to provide the output sample rate depending on the output configuration. LRCLK can also be an input. As an input LRCLK is independent of MCLK. *BIDIRECTIONAL - Default: INPUT.*

XMT958—SPDIF Transmitter Output: Pin 3

CMOS level output that contains a biphase-encoded clock for synchronously providing two channels of PCM digital audio or a IEC61937 compressed-data interface or both. This output typically connects to the input of an RS-422 transmitter or to the input of an optical transmitter. *OUTPUT.*

SCLKN1, STCCLK2—PCM Audio Input Bit Clock: Pin 25

Bidirectional digital-audio bit clock that is an output in master mode and an input in slave mode. In slave mode, SCLKN1 operates asynchronously from all other CS492X clocks. In master mode, SCLKN1 is derived from the CS492X internal clock generator. In either master or slave mode, the active edge of SCLKN1 can be programmed by the DSP. For applications supporting PES layer synchronization this pin can be used as STCCLK2, which provides a path to the internal STC 33 bit counter. *BIDIRECTIONAL - Default: INPUT.*

LRCLKN1—PCM Audio Input Sample Rate Clock: Pin 26

Bidirectional digital-audio frame clock that is an output in master mode and an input in slave mode. LRCLKN1 typically is run at the sampling frequency. In slave mode, LRCLKN1 operates asynchronously from all other CS492X clocks. In master mode, LRCLKN1 is derived from the CS492X internal clock generator. In either master or slave mode, the polarity of LRCLKN1 for a particular subframe can be programmed by the DSP.

BIDIRECTIONAL - Default: INPUT

SDATAN1—PCM Audio Data Input Number One: Pin 22

Digital-audio data input that can accept from one to six channels of compressed or PCM data. SDATAN1 can be sampled with either edge of SCLKN1, depending on how SCLKN1 has been configured. *INPUT*

CMPCLK, SCLKN2—PCM Audio Input Bit Clock: Pin 28

Bidirectional digital-audio bit clock that is an output in master mode and an input in slave mode. In slave mode, SCLKN2 operates asynchronously from all other CS492X clocks. In master mode, SCLKN2 is derived from the CS492X internal clock generator. In either master or slave mode, the active edge of SCLKN2 can be programmed by the DSP. If the CDI is configured for bursty delivery, CMPCLK is an input used to sample CMPDAT.

BIDIRECTIONAL - Default: INPUT

CMPREQ, LRCLKN2—PCM Audio Input Sample Rate Clock: Pin 29

When the CDI is configured as a digital audio input, this pin serves as a bidirectional digital-audio frame clock that is an output in master mode and an input in slave mode. LRCLKN2 typically is run at the sampling frequency. In slave mode, LRCLKN2 operates asynchronously from all other CS492X clocks. In master mode, LRCLKN2 is derived from the CS492X internal clock generator. In either master or slave mode, the polarity of LRCLKN2 for a particular subframe can be programmed by the DSP. When the CDI is configured for bursty delivery, or parallel audio data delivery is being used, CMPREQ is an output which serves as an internal FIFO monitor. CMPREQ is an active low signal that indicates when another block of data can be accepted. *BIDIRECTIONAL - Default: INPUT*

CMPDAT, SDATAN2—PCM Audio Data Input Number Two: Pin 27

Digital-audio data input that can accept from one to six channels of compressed or PCM data. SDATAN2 can be sampled with either edge of SCLKN2, depending on how SCLKN2 has been configured. Similarly CMPDAT is the compressed data input pin when the CDI is configured for bursty delivery. When in this mode, the CS4923/4/5/6/7/8/9 internal PLL is driven by the clock recovered from the incoming data stream. *INPUT*

DC—Reserved: Pin 38

This pin is reserved and should be pulled up with an external 4.7k resistor.

DD—Reserved: Pin 37

This pin is reserved and should be pulled up with an external 4.7k resistor.

9. PACKAGE DIMENSIONS

44L PLCC PACKAGE DRAWING

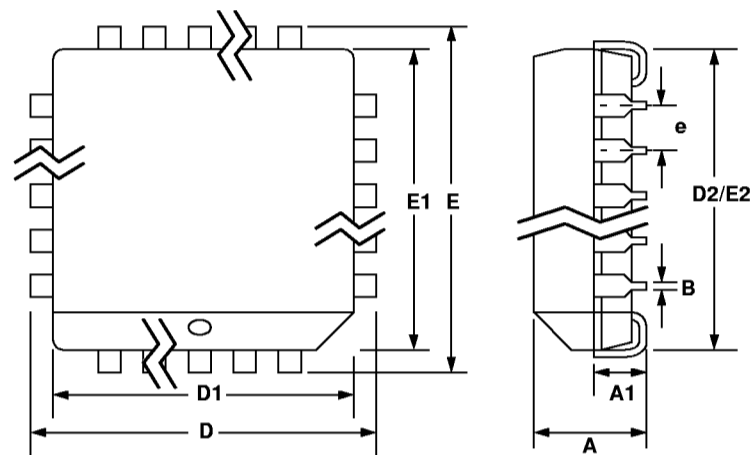

DIM	INCHES		MILLIMETERS	
	MIN	MAX	MIN	MAX
A	0.165	0.180	4.043	4.572
A1	0.090	0.120	2.205	3.048
B	0.013	0.021	0.319	0.533
D	0.685	0.695	16.783	17.653
D1	0.650	0.656	15.925	16.662
D2	0.590	0.630	14.455	16.002
E	0.685	0.695	16.783	17.653
E1	0.650	0.656	15.925	16.662
E2	0.590	0.630	14.455	16.002
e	0.040	0.060	0.980	1.524