

# Improved Triple 75MHz CRT Driver



Not recommended for new design. See CVA2400A.

## CVA2415T

### FEATURES

- Bandwidth ..... 75MHz
- Fall Time ..... 4.2ns
- Rise Time ..... 5.0ns
- Swing ..... 50 V<sub>P-P</sub>
- Excellent Gray Scale Linearity
- Supply Voltage ..... 80V
- Pin to Pin Compatible with LM2406

### APPLICATIONS

- CRT Driver for 1280 x 1024 and 1024 x 768 Color Monitors

### DESCRIPTION

The CVA2415T is an improved version that features excellent gray scale linearity with no crossover distortion and less EMI. Designed especially to drive high resolution monitor for resolution up to 1280 x 1024 (non-interlaced).

The part is housed in the industry standard 11-lead TO-220 molded power package. The heat sink is floating and may be grounded for ease of manufacturing and RFI shielding.

### ORDERING INFORMATION

Part	Package	Temperature
CVA2415T	T11A	-20°C to +100°C

### CONNECTION DIAGRAM AND SIMPLIFIED SCHEMATIC

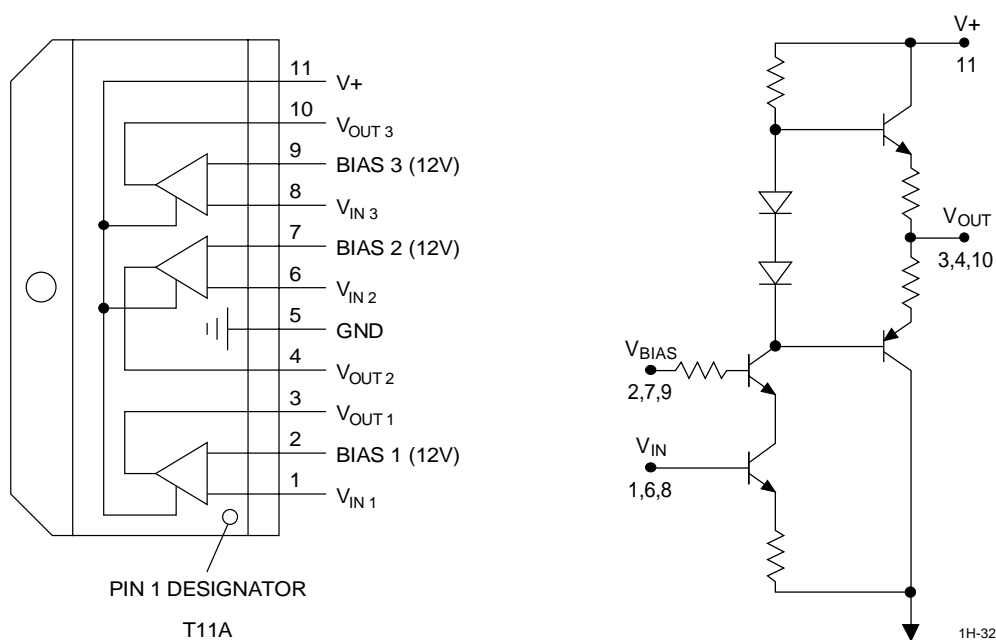

**ABSOLUTE MAXIMUM RATINGS**

Supply Voltage . . . . . 90V      Operating Temperature . . . . . -20°C to +100°C  
 Storage Temperature . . . . . -25°C to +100°C      Lead Temperature . . . . . +300°C

**DC ELECTRICAL CHARACTERISTICS**  $V_S = 80V, C_L = 12pF, V_{bias} = 12V, V_{in} = 3.4V, T_{case} = +25^\circ C$ . See Figure 1.

SYMBOL	CHARACTERISTICS	MIN	TYP	MAX	UNITS
I <sub>cc</sub>	Supply Current @ 1MHz	22	26	30	mA
I <sub>cc</sub>	Supply Current @ 50MHz		48		mA
V <sub>outDC</sub>	Output DC Level	38	42	46	V
A <sub>v</sub>	Voltage Gain	11	13	15	V
	Gain Matching		0.2		dB

**AC ELECTRICAL CHARACTERISTICS**  $V_S = 80V, C_L = 12pF, V_{bias} = 12V, T_{case} = +25^\circ C$ . See Figure 1.

SYMBOL	CHARACTERISTICS	MIN	TYP	MAX	UNITS
t <sub>r</sub>	Rise Time		5.0	7.0	ns
t <sub>f</sub>	Fall Time		4.2	6.0	ns
BW	Bandwidth		75		MHz
Le	Linearity		8.0		%
OS	Overshoot		0		%

**FIGURE 1. TEST CIRCUIT**

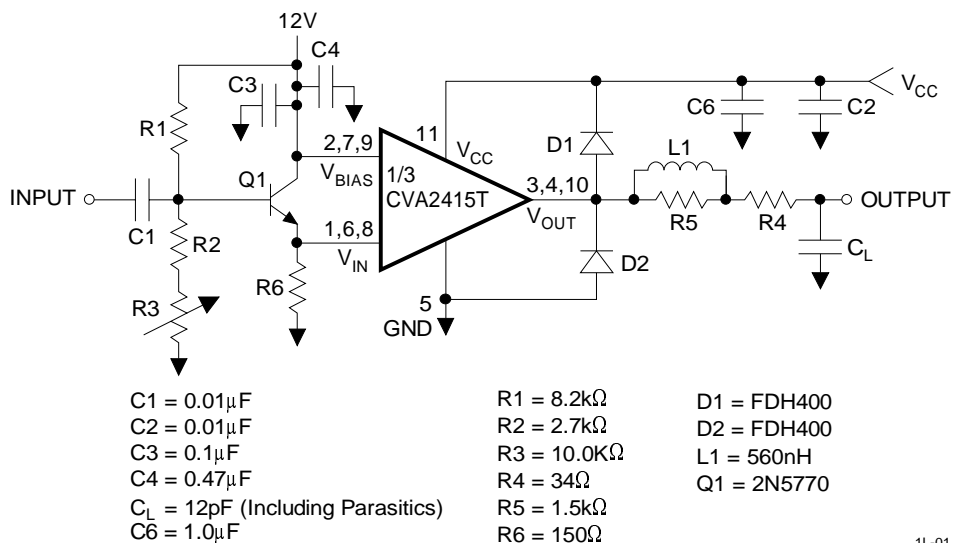

1L-01

## APPLICATION INFORMATION

The CVA2415T is a high voltage triple CRT driver suitable for VGA, Super VGA, IBM® 8514, 1280 x 1024 and 1024 x 768 non-interlaced display applications. The CVA2415T features 80V operation and low power dissipation. The part is housed in the industry standard 11 lead TO-220 molded power package. The heat sink is floating and may be grounded for ease of manufacturing and RFI shielding.

### Thermal Considerations

The transfer characteristics of the amplifier are shown in *Figure 2*. Since this is a class A input stage, power supply current increases as the input signal increases and consequently power dissipation also increases. Average power dissipation per stage is 2.8W, increasing to 4.8W at minimum output voltage.

The CVA2415T cannot be used without heat sinking. *Figure 2* shows the power dissipated in each channel over the operating voltage range of the device, typical "average" power dissipation with the device output voltage at one half the supply voltage is 2.2W per channel for a total dissipation of 6.6W package dissipation. Under white screen conditions, i.e. 20V output, dissipation increases to 3.4W per channel or 10.3W total. The CVA2415T case temperature must be maintained below +100°C. If the maximum expected ambient temperature is +50°C, then a heat sink is needed with thermal resistance equal to or less than:

$$R_{th} = \frac{(100 - 50^{\circ}\text{C})}{14.4\text{W}} = 4.8^{\circ}\text{C/W}$$

**FIGURE 2. CVA2415T DC Characteristics**

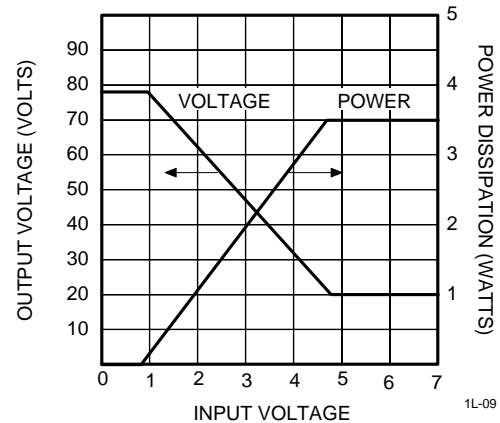

The CVA2415T maximum load is 600Ω to ground or V<sup>+</sup>.

The output of CVA2415T is not short circuit proof. Any resistance to V<sup>+</sup> or Ground should be > 600Ω.

**FIGURE 3.**

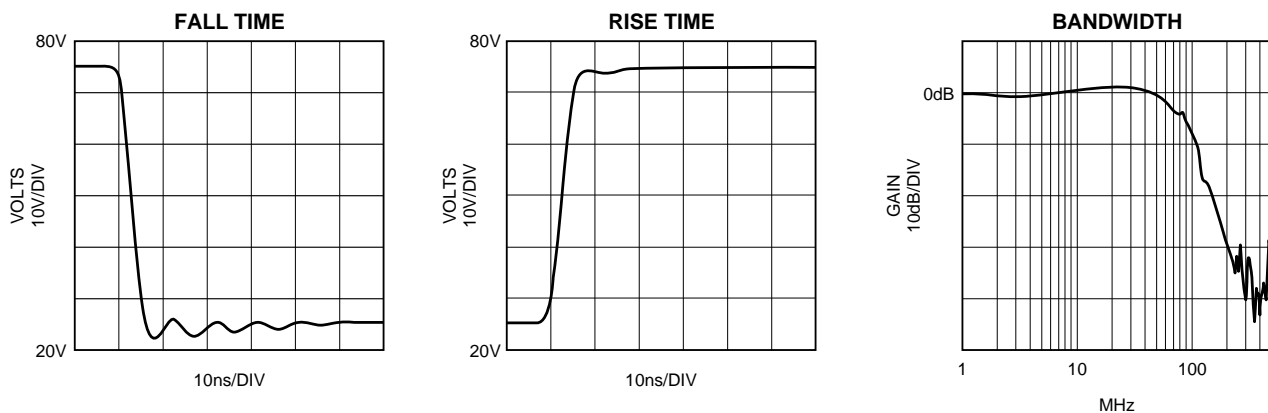

**TYPICAL APPLICATION**

A typical application of the CVA2415T is shown in *Figure 4*.

**FIGURE 4. TYPICAL APPLICATION**

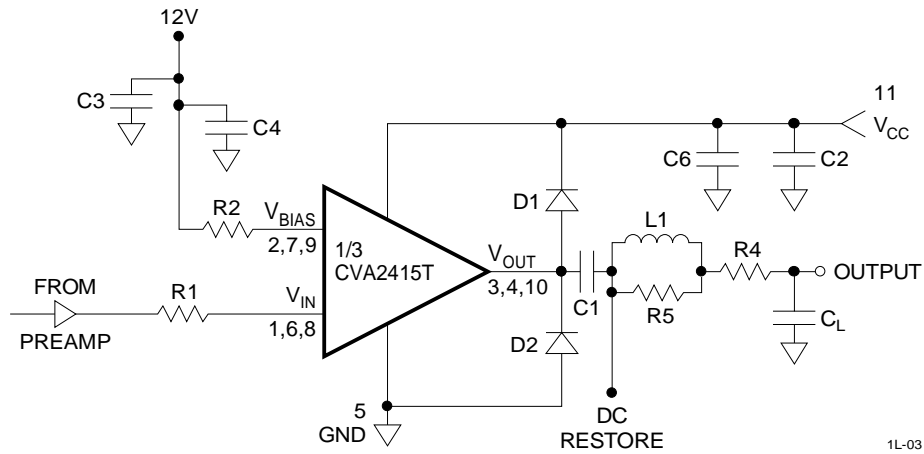

1L-03

	C1 $\mu\text{F}$	C2 $\mu\text{F}$	C3 $\mu\text{F}$	C4 $\mu\text{F}$	CL* pF	C6 $\mu\text{F}$	R1 $\Omega$	R2 $\Omega$	R4 $\Omega$	R5 K $\Omega$	D1	D2	L1 nH
<b>CVA2415T</b>	1.0	0.01	0.1	0.47	12	1.0	22	47	34	1.5	FDH400	FDH400	560