

CXM3519ER

Description

The CXM3519ER is a SP9T/SP10T antenna switch module for GSM and UMTS/CDMA dual-mode handset. This IC has a built-in dual low pass filter and a +1.8V CMOS compatible decoder. The Sony GaAs junction gate pHEMT (JPHEMT) MMIC process is used for low insertion loss and high linearity. The device has low BOM and small mount Area with no DC blocking capacitor.

Features

- ◆ Low insertion loss (SP10T): 0.85dB (Typ.) Tx1 (GSM Low Band Tx)
0.88dB (Typ.) Tx2 (GSM High Band Tx)
0.50dB (Typ.) TRx1 (UMTS Band I)
- ◆ Low insertion loss (SP9T): 0.85dB (Typ.) Tx1 (GSM Low Band Tx)
0.85dB (Typ.) Tx2 (GSM High Band Tx)
0.47dB (Typ.) TRx1 (UMTS Band I)
- ◆ High attenuation: 35dB (Typ.) On Tx1 path @1648 – 1830MHz
33dB (Typ.) On Tx2 path @3420 – 3820MHz
- ◆ Low voltage operation: $V_{DD} = +2.5V$
- ◆ No DC blocking capacitors
- ◆ Small package: VQFN-26P (3.0mm × 3.8mm × 0.8mm Typ.)
- ◆ Lead-Free and RoHS compliant

Structure

GaAs Junction-gate PHEMT MMIC Switch, CMOS Decoder and Dual-LPF.

Note on Handling

- GaAs MMIC's are ESD sensitive devices. Special handling precautions are required.

Sony reserves the right to change products and specifications without prior notice. This information does not convey any license by any implication or otherwise under any patents or other right. Application circuits shown, if any, are typical examples illustrating the operation of the devices. Sony cannot assume responsibility for any problems arising out of the use of these circuits.

Block Diagram (SP9T/SP10T)

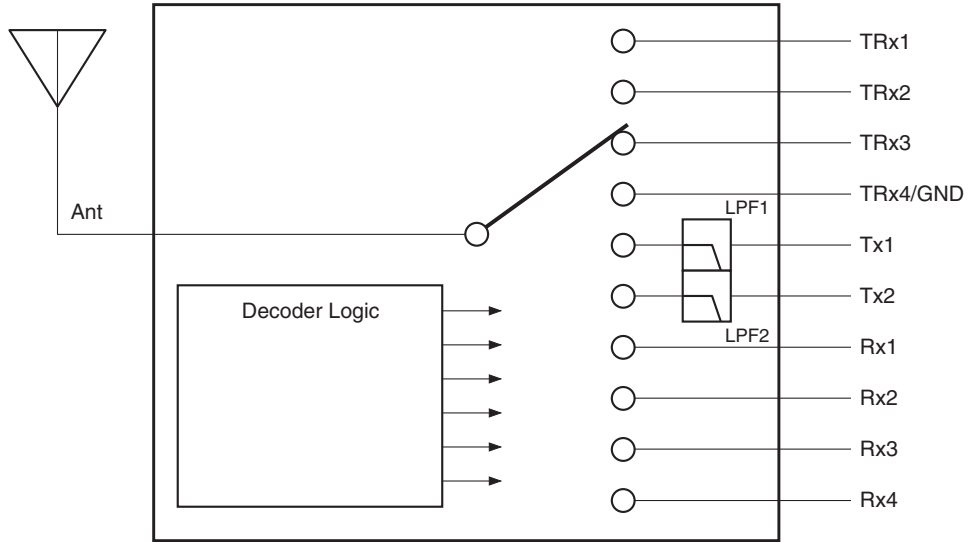

Pin Configuration

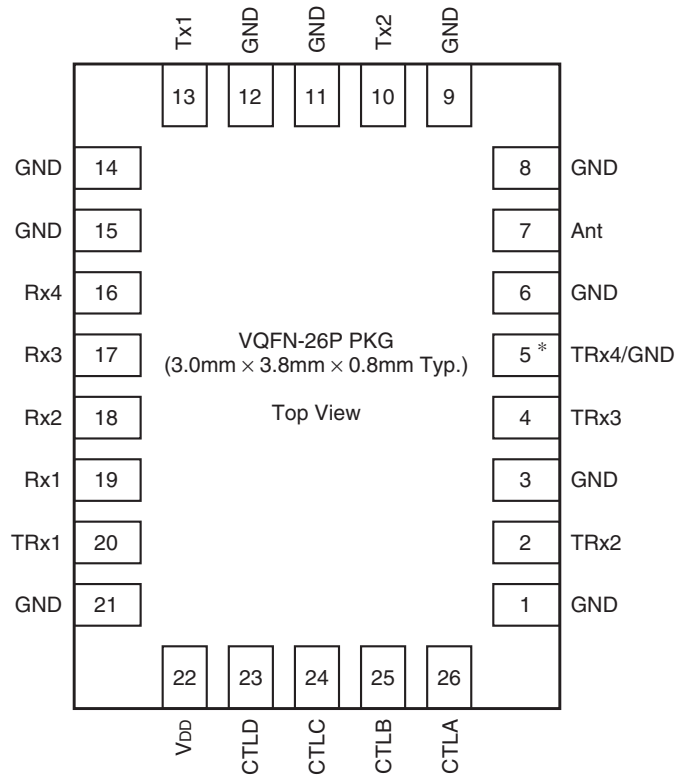

* Pin 5
 SP9T : Connect to GND directly
 SP10T : TRx4

 **Pin Description**

Pin No.	Symbol	Pin No.	Symbol
1	GND	14	GND
2	TRx2	15	GND
3	GND	16	Rx4
4	TRx3	17	Rx3
5	TRx4/GND	18	Rx2
6	GND	19	Rx1
7	Ant	20	TRx1
8	GND	21	GND
9	GND	22	V _{DD}
10	Tx2 (DCS/PCS)	23	CTLD
11	GND	24	CTLG
12	GND	25	CTLB
13	Tx1 (GSM850/900M)	26	CTLA

RF Switch (SP9T/SP10T)

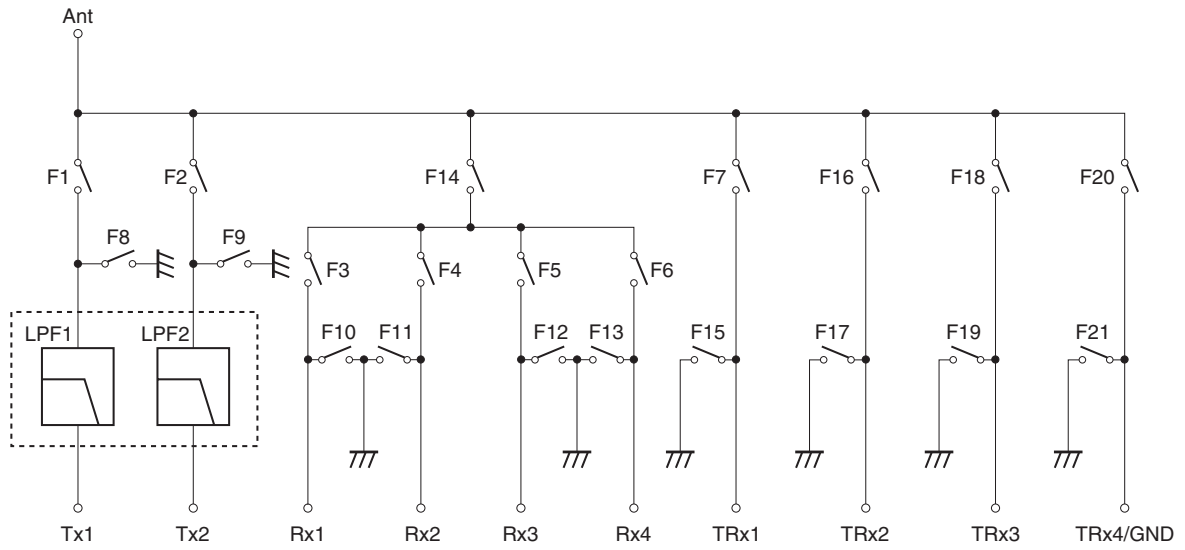

Truth Table

State	Active path	Vctl state				Switch state*2																						
		A	B	C	D	F1	F2	F3	F4	F5	F6	F7	F8	F9	F10	F11	F12	F13	F14	F15	F16	F17	F18	F19	F20	F21		
1	Tx1	H	H	L	L	H	L	L	L	L	L	L	L	H	H	H	H	H	L	H	L	H	L	H	L	H		
2	Tx2	H	L	L	L	L	H	L	L	L	L	L	H	L	H	H	H	H	L	H	L	H	L	H	L	H		
3	Rx1*1	L	L	L	L	L	L	H	L	L	L	L	H	H	L	H	H	H	H	L	H	L	H	L	H	L	H	
4	Rx2*1	L	L	H	L	L	L	L	H	L	L	L	H	H	H	L	H	H	H	H	L	H	L	H	L	H	L	H
5	Rx3*1	L	H	H	L	L	L	L	L	H	L	L	H	H	H	H	L	H	H	H	L	H	L	H	L	H	L	H
6	Rx4*1	L	H	L	L	L	L	L	L	L	H	L	H	H	H	H	H	L	H	H	L	H	L	H	L	H	L	H
7	TRx1	H	L	H	L	L	L	L	L	L	L	L	H	H	H	H	H	H	L	L	L	H	L	H	L	H	L	H
8	TRx2	H	H	H	L	L	L	L	L	L	L	L	H	H	H	H	H	H	L	H	H	L	L	H	L	H	L	H
9	TRx3	H	L	H	H	L	L	L	L	L	L	L	H	H	H	H	H	H	L	H	L	H	H	L	L	H	L	H
10	TRx4	H	H	H	H	L	L	L	L	L	L	L	H	H	H	H	H	H	L	H	L	H	L	H	H	H	L	L

*1 Each Rx path can be used from 869MHz to 1990MHz frequency, user can select these Rx paths changeably.

*2 State "L" means a switch "OFF", state "H" means a switch "ON".

Electrical Characteristics

Supply Voltage

(Ta = 25°C)

Item	Min.	Typ.	Max.	Unit
Bias voltage (V _{DD})	2.5	2.65	3.3	V

Logic Value

(Ta = 25°C)

Item	State	Min.	Typ.	Max.	Unit
Control voltage (CTL-A/B/C/D)	High	1.5	1.80	3.3	V
	Low	0	—	0.3	

Absolute Maximum Ratings

Item	Ratings
Bias voltage (V _{DD})	4V (Ta: +25°C)
Control voltage (CTL-A/B/C/D)	4V (Ta: +25°C)
Maximum input power (Tx1)	+36dBm (Duty cycle = 12.5%) (Ta: +25°C)
Maximum input power (Tx2)	+34dBm (Duty cycle = 12.5%) (Ta: +25°C)
Maximum input power (TRx1, 2, 3, 4)	+32dBm (Ta: +25°C)
Maximum input power (Rx1, 2, 3, 4)	+13dBm (Ta: +25°C)
Operating temperature	-20 to +90°C
Storage temperature	-65 to +150°C

Recommended Circuit 1 (SP9T)

Ex.) GSM (4 bands) / UMTS (3 bands)

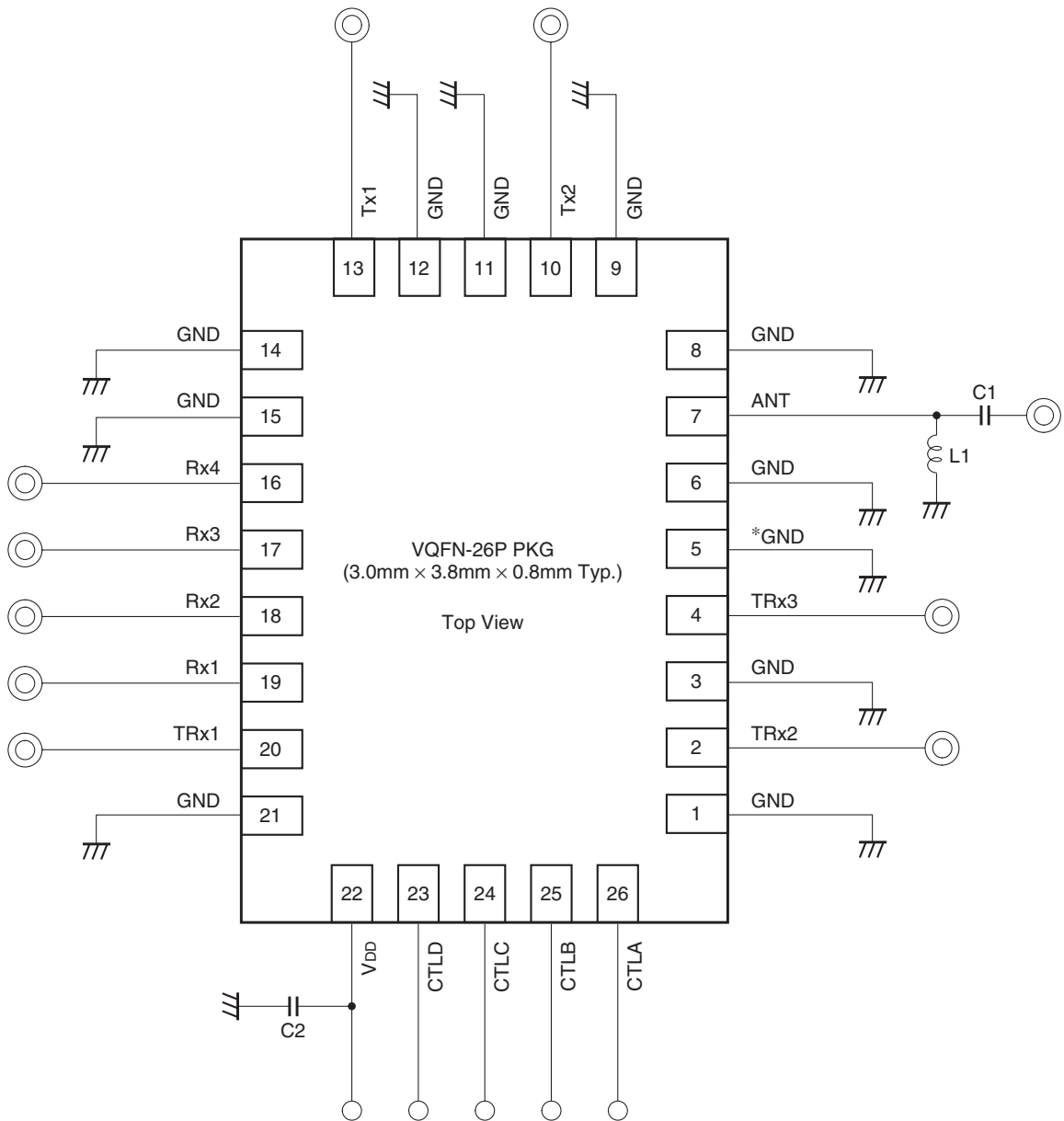

- Note) 1. No DC blocking capacitors are required on all RF ports.
- 2. The DC levels of all RF ports are GND.
- 3. L1 inductor (22nH) and C1 capacitor (22pF) are recommended on Ant port for ESD protection.
- 4. C2 capacitor (100pF) is recommended.
- 5. Connect Pin 5 to GND directly.

Electrical Characteristics (Recommended Circuit 1 (SP9T))

(V_{DD} = 2.65V, V_{ctl} = 1.80V, T_a = 25°C)

Item	Symbol	Path	Conditions	Min.	Typ.	Max.	Unit
Insertion loss	I.L	Ant-Tx1	*1	—	0.85	1.00	dB
		Ant-Tx2	*2	—	0.85	1.05	
		Ant-TRx1 (Tx)	*3	—	0.47	0.62	
		Ant-TRx1 (Rx)	*4	—	0.48	0.63	
		Ant-TRx2 (Tx)	*5	—	0.51	0.61	
		Ant-TRx2 (Rx)	*6	—	0.57	0.72	
		Ant-TRx3 (Tx)	*5	—	0.48	0.58	
		Ant-TRx3 (Rx)	*6	—	0.56	0.71	
		Ant-Rx1	*7	—	0.66	0.76	
			*8		1.02	1.17	
		Ant-Rx2	*7	—	0.65	0.75	
			*8		1.01	1.16	
		Ant-Rx3	*7	—	0.65	0.75	
			*8		0.98	1.13	
		Ant-Rx4	*7	—	0.65	0.75	
			*8		0.94	1.09	

Electrical characteristics are measured with all RF ports terminated in 50Ω and recommended circuit 1 (SP9T).

- *1 Frequency = 824 to 915MHz, Pin on Tx1: +34dBm C.W.
- *2 Frequency = 1710 to 1910MHz, Pin on Tx2: +32dBm C.W.
- *3 Frequency = 1920 to 1980MHz, Pin on TRx1: +26dBm C.W.
- *4 Frequency = 2110 to 2170MHz, Pin on TRx1: +26dBm C.W.
- *5 Frequency = 824 to 894MHz, Pin on TRx2 or 3: +26dBm C.W.
- *6 Frequency = 1710 to 1990MHz, Pin on TRx2 or 3: +26dBm C.W.
- *7 Frequency = 869 to 960MHz, Pin on Ant: +10dBm C.W.
- *8 Frequency = 1805 to 1990MHz, Pin on Ant: +10dBm C.W.

Item	Symbol	Path	Conditions	Min.	Typ.	Max.	Unit	
Isolation	ISO.	Active path: Tx1-Ant (State1)						dB
		Tx1-Rx1	824 to 915MHz	35	42	—		
		Tx1-Rx2		35	42	—		
		Tx1-Rx3		35	42	—		
		Tx1-Rx4		35	42	—		
		Tx1-TRx1		35	39	—		
		Tx1-TRx2		45	54	—		
		Tx1-TRx3		45	57	—		
		Tx1-Tx2		20	23	—		
		Tx2-Ant		20	22	—		
		Active path: Tx2-Ant (State2)						
		Tx2-Rx1	1710 to 1910MHz	32	37	—		
		Tx2-Rx2		32	37	—		
		Tx2-Rx3		32	37	—		
		Tx2-Rx4		32	38	—		
		Tx2-TRx1		30	33	—		
		Tx2-TRx2		40	49	—		
		Tx2-TRx3		40	44	—		
		Tx2-Tx1		20	26	—		

Electrical Characteristics (Recommended Circuit 1 (SP9T))

(V_{DD} = 2.65V, V_{ctl} = 1.80V, Ta = 25°C)

Item	Symbol	Path	Conditions	Min.	Typ.	Max.	Unit	
Isolation	ISO.	Active path: TRx1-Ant (State7)						dB
		TRx1-Rx1	1920 to 1980MHz	17	19	—		
		TRx1-Rx2		20	27	—		
		TRx1-Rx3		30	34	—		
		TRx1-Rx4		35	41	—		
		TRx1-Tx1		35	42	—		
		TRx1-Tx2		25	30	—		
		TRx1-TRx2		40	45	—		
		TRx1-TRx3		35	42	—		
		Active path: TRx2-Ant (State8)						
		TRx2-Rx1	824 to 849MHz	35	40	—		
		TRx2-Rx2		35	41	—		
		TRx2-Rx3		35	43	—		
		TRx2-Rx4		40	45	—		
		TRx2-Tx1		35	40	—		
		TRx2-Tx2		35	42	—		
		TRx2-TRx1		30	37	—		
		TRx2-TRx3		30	36	—		
		TRx2-Rx1		1710 to 1910MHz	25	32	—	
		TRx2-Rx2	25		33	—		
		TRx2-Rx3	30		35	—		
		TRx2-Rx4	30		38	—		
		TRx2-Tx1	45		56	—		
		TRx2-Tx2	25		32	—		
		TRx2-TRx1	25		29	—		
		TRx2-TRx3	25		31	—		
		Active path: TRx3-Ant (State9)						
		TRx3-Rx1	824 to 849MHz	35	41	—		
		TRx3-Rx2		35	42	—		
		TRx3-Rx3		35	43	—		
		TRx3-Rx4		40	46	—		
		TRx3-Tx1		35	40	—		
		TRx3-Tx2		40	43	—		
		TRx3-TRx1		30	37	—		
		TRx3-TRx2		30	37	—		
		TRx3-Rx1		1710 to 1910MHz	25	33	—	
		TRx3-Rx2	25		33	—		
		TRx3-Rx3	30		35	—		
		TRx3-Rx4	30		38	—		
		TRx3-Tx1	45		52	—		
		TRx3-Tx2	25		33	—		
		TRx3-TRx1	25		30	—		
		TRx3-TRx2	25		30	—		

Electrical Characteristics (Recommended Circuit 1 (SP9T))

(V_{DD} = 2.65V, V_{ctl} = 1.80V, T_a = 25°C)

Item	Symbol	Path	Conditions		Min.	Typ.	Max.	Unit
Intermodulation distortion level in Rx band	IMD2	TRx1-Ant	TRx: 835MHz State7	Ant: 45MHz *1	—	-119	-105	dBm
				Ant: 1715MHz *2	—	-118	-105	
			TRx: 1880MHz State7	Ant: 80MHz *3	—	-108	-103	
				Ant: 3840MHz *4	—	-110	-105	
			TRx: 1950MHz State7	Ant: 190MHz *5	—	-108	-103	
				Ant: 4090MHz *6	—	-117	-105	
		TRx2-Ant	TRx: 835MHz State8	Ant: 45MHz *1	—	-119	-105	
				Ant: 1715MHz *2	—	-117	-105	
			TRx: 1880MHz State8	Ant: 80MHz *3	—	-107	-102	
				Ant: 3840MHz *4	—	-107	-102	
			TRx: 1950MHz State8	Ant: 190MHz *5	—	-109	-104	
				Ant: 4090MHz *6	—	-116	-105	
		TRx3-Ant	TRx: 835MHz State9	Ant: 45MHz *1	—	-118	-105	
				Ant: 1715MHz *2	—	-117	-105	
			TRx: 1880MHz State9	Ant: 80MHz *3	—	-106	-101	
				Ant: 3840MHz *4	—	-110	-105	
			TRx: 1950MHz State9	Ant: 190MHz *5	—	-107	-102	
				Ant: 4090MHz *6	—	-118	-105	
	IMD3	TRx1-Ant	TRx: 835MHz State7	Ant: 790MHz *7	—	-108	-103	
				Ant: 2550MHz *8	—	-110	-105	
			TRx: 1880MHz State7	Ant: 1800MHz *9	—	-107	-102	
				Ant: 5720MHz *10	—	-112	-105	
			TRx: 1950MHz State7	Ant: 1760MHz *11	—	-107	-102	
				Ant: 6040MHz *12	—	-115	-105	
		TRx2-Ant	TRx: 835MHz State8	Ant: 790MHz *7	—	-106	-101	
				Ant: 2550MHz *8	—	-110	-105	
			TRx: 1880MHz State8	Ant: 1800MHz *9	—	-105	-100	
				Ant: 5720MHz *10	—	-110	-105	
			TRx: 1950MHz State8	Ant: 1760MHz *11	—	-105	-100	
				Ant: 6040MHz *12	—	-112	-105	
		TRx3-Ant	TRx: 835MHz State9	Ant: 790MHz *7	—	-108	-103	
				Ant: 2550MHz *8	—	-110	-105	
			TRx: 1880MHz State9	Ant: 1800MHz *9	—	-105	-100	
				Ant: 5720MHz *10	—	-106	-101	
			TRx: 1950MHz State9	Ant: 1760MHz *11	—	-105	-100	
				Ant: 6040MHz *12	—	-110	-105	

Electrical characteristics are measured with all RF ports terminated in 50Ω and recommended circuit 1 (SP9T).

- *1 TRx port: +20dBm, 835MHz, Ant port: -15dBm, 45MHz
- *2 TRx port: +20dBm, 835MHz, Ant port: -15dBm, 1715MHz
- *3 TRx port: +20dBm, 1880MHz, Ant port: -15dBm, 80MHz
- *4 TRx port: +20dBm, 1880MHz, Ant port: -15dBm, 3840MHz
- *5 TRx port: +20dBm, 1950MHz, Ant port: -15dBm, 190MHz
- *6 TRx port: +20dBm, 1950MHz, Ant port: -15dBm, 4090MHz
- *7 TRx port: +20dBm, 835MHz, Ant port: -15dBm, 790MHz
- *8 TRx port: +20dBm, 835MHz, Ant port: -15dBm, 2550MHz
- *9 TRx port: +20dBm, 1880MHz, Ant port: -15dBm, 1800MHz
- *10 TRx port: +20dBm, 1880MHz, Ant port: -15dBm, 5720MHz
- *11 TRx port: +20dBm, 1950MHz, Ant port: -15dBm, 1760MHz
- *12 TRx port: +20dBm, 1950MHz, Ant port: -15dBm, 6040MHz

Electrical Characteristics (Recommended Circuit 1 (SP9T))

(V_{DD} = 2.65V, V_{ctl} = 1.80V, T_a = 25°C)

Item	Symbol	Path	Conditions	Min.	Typ.	Max.	Unit	
Harmonics	Harm	Tx1-Ant *1	2nd harmonic 1648 to 1698MHz 1780 to 1830MHz	C.W. Pin = +34dBm	—	-49	-36	dBm
			3rd harmonic 2472 to 2547MHz 2670 to 2745MHz		—	-44	-36	
		Tx2-Ant *2	2nd harmonic 3420 to 3570MHz 3700 to 3820MHz	C.W. Pin = +32dBm	—	-53	-36	
			3rd harmonic 5130 to 5355MHz 5550 to 5730MHz		—	-45	-36	
		TRx1-Ant *3	2nd harmonic 3840 to 3960MHz	C.W. Pin = +26dBm	—	-65	-36	
			3rd harmonic 5760 to 5940MHz		—	-63	-36	
		TRx2-Ant *3	2nd harmonic 3840 to 3960MHz	C.W. Pin = +26dBm	—	-63	-36	
			3rd harmonic 5760 to 5940MHz		—	-61	-36	
		TRx3-Ant *3	2nd harmonic 3840 to 3960MHz	C.W. Pin = +26dBm	—	-65	-36	
			3rd harmonic 5760 to 5940MHz		—	-58	-36	

Electrical characteristics are measured with all RF ports terminated in 50Ω and recommended circuit 1 (SP9T).

*1 Frequency = 824 to 915MHz, Pin on Tx1: +34dBm C.W.

*2 Frequency = 1710 to 1910MHz, Pin on Tx2: +32dBm C.W.

*3 Frequency = 1920 to 1980MHz, Pin on TRx1 or TRx2 or TRx3: +26dBm C.W.

Item	Symbol	Path	Conditions	Min.	Typ.	Max.	Unit	
Attenuation	ATT	Tx1-Ant	1648 to 1830MHz	2fo	25	35	—	dB
			2472 to 2745MHz	3fo	25	35	—	
			3296 to 3660MHz	4fo	20	24	—	
		Tx2-Ant	3420 to 3820MHz	2fo	25	33	—	
			5130 to 5730MHz	3fo	25	32	—	

Item	Symbol	Path	Conditions	Min.	Typ.	Max.	Unit
Switching time	T _s		90% OFF to 90% ON		2	5	μs
Control current	I _{ctl}				—	10	μA
Supply current	I _{DD}		Active mode		0.22	0.4	mA
V.S.W.R.	V.S.W.R.	All ports in active paths	824 to 2170MHz		1.2		—

Recommended Circuit 2 (SP10T)

Ex.) GSM (4 bands) / UMTS (4 bands)

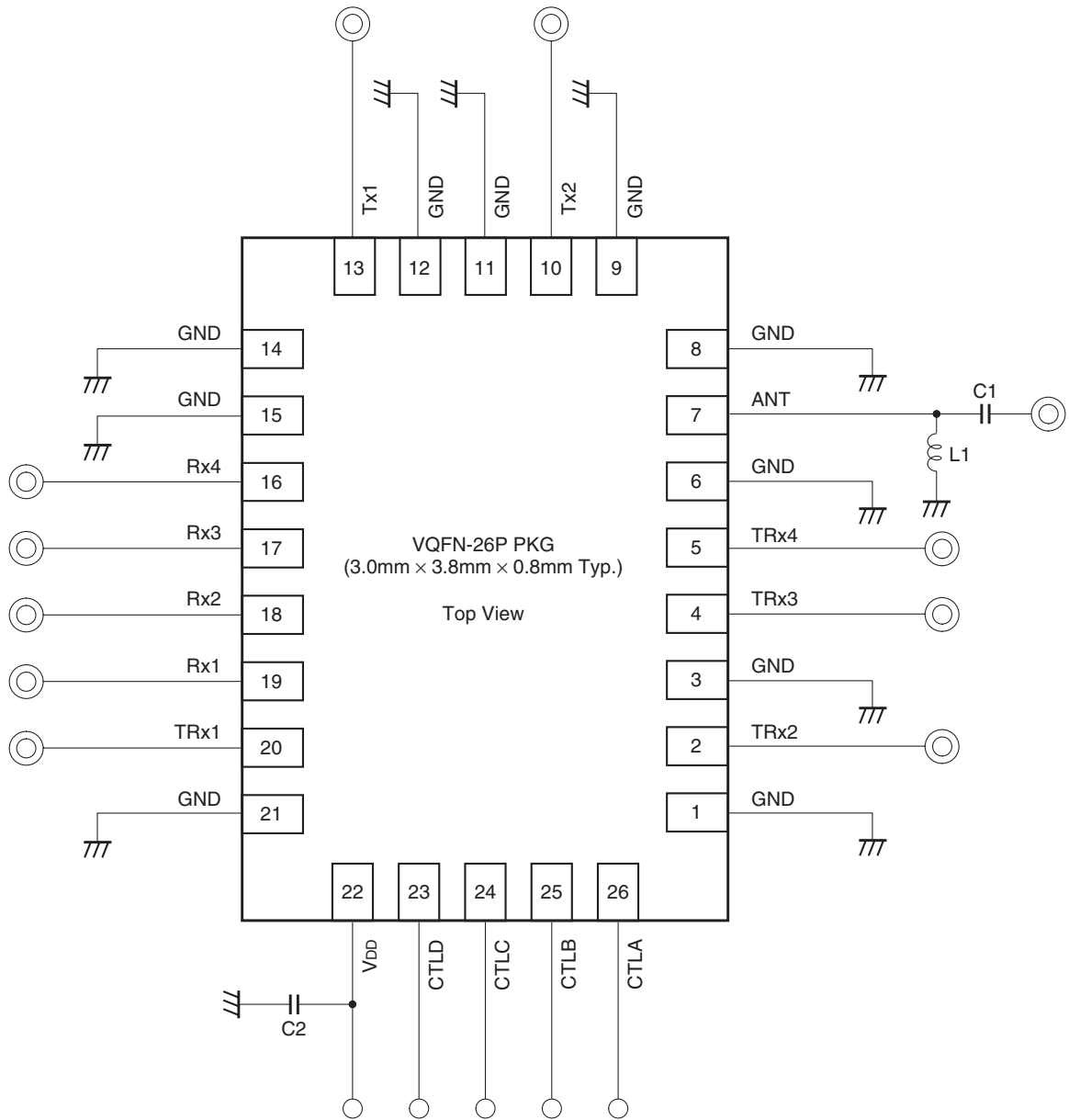

- Note) 1. No DC blocking capacitors are required on all RF ports.
 2. DC levels of all RF ports are GND.
 3. L1 inductor (22nH) and C1 capacitor (22pF) are recommended on Ant port for ESD protection.
 4. C2 capacitor (100pF) is recommended.

Electrical Characteristics (Recommended Circuit 2 (SP10T))

(V_{DD} = 2.65V, V_{ctl} = 1.80V, T_a = 25°C)

Item	Symbol	Path	Conditions	Min.	Typ.	Max.	Unit
Insertion loss	I.L	Ant-Tx1	*1	—	0.85	1.00	dB
		Ant-Tx2	*2	—	0.88	1.08	
		Ant-TRx1 (Tx)	*3	—	0.50	0.65	
		Ant-TRx1 (Rx)	*4	—	0.52	0.67	
		Ant-TRx2 (Tx)	*5	—	0.53	0.63	
		Ant-TRx2 (Rx)	*6	—	0.59	0.74	
		Ant-TRx3 (Tx)	*5	—	0.49	0.59	
		Ant-TRx3 (Rx)	*6	—	0.61	0.76	
		Ant-TRx4 (Tx)	*7	—	0.40	0.50	
		Ant-TRx4 (Rx)	*8	—	0.40	0.50	
		Ant-Rx1	*9	—	0.67	0.77	
			*10	—	1.04	1.19	
		Ant-Rx2	*9	—	0.64	0.74	
			*10	—	1.03	1.18	
		Ant-Rx3	*9	—	0.65	0.75	
			*10	—	0.98	1.13	
		Ant-Rx4	*9	—	0.65	0.75	
			*10	—	0.95	1.10	

Electrical characteristics are measured with all RF ports terminated in 50Ω and recommended circuit 2 (SP10T).

- *1 Frequency = 824 to 915MHz, Pin on Tx1: +34dBm C.W.
- *2 Frequency = 1710 to 1910MHz, Pin on Tx2: +32dBm C.W.
- *3 Frequency = 1920 to 1980MHz, Pin on TRx1: +26dBm C.W.
- *4 Frequency = 2110 to 2170MHz, Pin on TRx1: +26dBm C.W.
- *5 Frequency = 824 to 894MHz, Pin on TRx2 or 3: +26dBm C.W.
- *6 Frequency = 1710 to 1990MHz, Pin on TRx2 or 3: +26dBm C.W.
- *7 Frequency = 824 to 849MHz, Pin on TRx4: +26dBm C.W.
- *8 Frequency = 869 to 894MHz, Pin on TRx4: +26dBm C.W.
- *9 Frequency = 869 to 960MHz, Pin on Ant: +10dBm C.W.
- *10 Frequency = 1805 to 1990MHz, Pin on Ant: +10dBm C.W.

Item	Symbol	Path	Conditions	Min.	Typ.	Max.	Unit				
Isolation	ISO.	Active path: Tx1-Ant (State1)			824 to 915MHz			dB			
		Tx1-Rx1	35	42					—		
		Tx1-Rx2	35	42					—		
		Tx1-Rx3	35	42					—		
		Tx1-Rx4	35	42					—		
		Tx1-TRx1	35	39					—		
		Tx1-TRx2	45	54					—		
		Tx1-TRx3	45	57					—		
		Tx1-TRx4	30	36					—		
		Tx1-Tx2	20	23					—		
		Tx2-Ant	20	23					—		
			25	28					—		
		Active path: Tx2-Ant (State2)							1710 to 1910MHz		
		Tx2-Rx1	32	37							
		Tx2-Rx2	32	37	—						
		Tx2-Rx3	32	37	—						
		Tx2-Rx4	32	38	—						
		Tx2-TRx1	30	33	—						
		Tx2-TRx2	40	49	—						
		Tx2-TRx3	40	44	—						
Tx2-TRx4	20	26	—								
Tx2-Tx1	20	26	—								

Electrical Characteristics (Recommended Circuit 2 (SP10T))

(V_{DD} = 2.65V, V_{ctl} = 1.80V, Ta = 25°C)

Item	Symbol	Path	Conditions	Min.	Typ.	Max.	Unit		
Isolation	ISO.	Active path: TRx1-Ant (State7)					dB		
		TRx1-Rx1	1920 to 1980MHz	17	19	—			
		TRx1-Rx2		20	27	—			
		TRx1-Rx3		30	34	—			
		TRx1-Rx4		35	41	—			
		TRx1-Tx1		35	42	—			
		TRx1-Tx2		25	30	—			
		TRx1-TRx2		40	45	—			
		TRx1-TRx3		35	42	—			
		TRx1-TRx4		20	25	—			
		Active path: TRx2-Ant (State8)							
		TRx2-Rx1	824 to 849MHz	35	41	—			
		TRx2-Rx2		35	41	—			
		TRx2-Rx3		35	43	—			
		TRx2-Rx4		40	45	—			
		TRx2-Tx1		35	40	—			
		TRx2-Tx2		35	42	—			
		TRx2-TRx1		30	37	—			
		TRx2-TRx3		30	36	—			
		TRx2-TRx4		30	36	—			
		TRx2-Rx1		1710 to 1910MHz	25	32		—	
		TRx2-Rx2			25	33		—	
		TRx2-Rx3			30	35		—	
		TRx2-Rx4			30	38		—	
		TRx2-Tx1			45	56		—	
		TRx2-Tx2			25	32		—	
		TRx2-TRx1	25		29	—			
		TRx2-TRx3	25		31	—			
		TRx2-TRx4	20		25	—			
		Active path: TRx3-Ant (State9)							
		TRx3-Rx1	824 to 849MHz	35	41	—			
		TRx3-Rx2		35	42	—			
		TRx3-Rx3		35	43	—			
		TRx3-Rx4		40	46	—			
		TRx3-Tx1		35	40	—			
		TRx3-Tx2		40	44	—			
		TRx3-TRx1		30	37	—			
		TRx3-TRx2		30	37	—			
		TRx3-TRx4		30	34	—			
		TRx3-Rx1	1710 to 1910MHz	25	33	—			
		TRx3-Rx2		25	33	—			
		TRx3-Rx3		30	35	—			
		TRx3-Rx4		30	38	—			
		TRx3-Tx1		45	52	—			
		TRx3-Tx2		25	34	—			
		TRx3-TRx1		25	30	—			
		TRx3-TRx2		25	30	—			
		TRx3-TRx4		17	21	—			
Active path: TRx4-Ant (State10)									
TRx4-Rx1	824 to 849MHz	35	41	—					
TRx4-Rx2		35	42	—					
TRx4-Rx3		35	43	—					
TRx4-Rx4		40	46	—					
TRx4-Tx1		35	40	—					
TRx4-Tx2		40	44	—					
TRx4-TRx1		30	37	—					
TRx4-TRx2		40	47	—					
TRx4-TRx3		30	34	—					

Electrical Characteristics (Recommended Circuit 2 (SP10T))

(V_{DD} = 2.65V, V_{ctl} = 1.80V, T_a = 25°C)

Item	Symbol	Path	Conditions		Min.	Typ.	Max.	Unit
Intermodulation distortion level in Rx band	IMD2	TRx1-Ant	TRx: 835MHz State7	Ant: 45MHz *1	—	-119	-105	dBm
				Ant: 1715MHz *2	—	-118	-105	
			TRx: 1880MHz State7	Ant: 80MHz *3	—	-108	-103	
				Ant: 3840MHz *4	—	-110	-105	
			TRx: 1950MHz State7	Ant: 190MHz *5	—	-108	-103	
				Ant: 4090MHz *6	—	-117	-105	
		TRx2-Ant	TRx: 835MHz State8	Ant: 45MHz *1	—	-119	-105	
				Ant: 1715MHz *2	—	-117	-105	
			TRx: 1880MHz State8	Ant: 80MHz *3	—	-107	-102	
				Ant: 3840MHz *4	—	-107	-102	
			TRx: 1950MHz State8	Ant: 190MHz *5	—	-109	-104	
				Ant: 4090MHz *6	—	-116	-105	
		TRx3-Ant	TRx: 835MHz State9	Ant: 45MHz *1	—	-118	-105	
				Ant: 1715MHz *2	—	-117	-105	
			TRx: 1880MHz State9	Ant: 80MHz *3	—	-106	-101	
				Ant: 3840MHz *4	—	-110	-105	
			TRx: 1950MHz State9	Ant: 190MHz *5	—	-107	-102	
				Ant: 4090MHz *6	—	-118	-105	
		TRx4-Ant	TRx: 835MHz State10	Ant: 45MHz *1	—	-117	-105	
				Ant: 1715MHz *2	—	-116	-105	
			TRx: 1880MHz State10	Ant: 80MHz *3	—	-105	-100	
				Ant: 3840MHz *4	—	-110	-105	
			TRx: 1950MHz State10	Ant: 190MHz *5	—	-106	-101	
				Ant: 4090MHz *6	—	-118	-105	
	IMD3	TRx1-Ant	TRx: 835MHz State7	Ant: 790MHz *7	—	-108	-103	
				Ant: 2550MHz *8	—	-110	-105	
			TRx: 1880MHz State7	Ant: 1800MHz *9	—	-107	-102	
				Ant: 5720MHz *10	—	-112	-105	
			TRx: 1950MHz State7	Ant: 1760MHz *11	—	-107	-102	
				Ant: 6040MHz *12	—	-115	-105	
		TRx2-Ant	TRx: 835MHz State8	Ant: 790MHz *7	—	-106	-101	
				Ant: 2550MHz *8	—	-110	-105	
			TRx: 1880MHz State8	Ant: 1800MHz *9	—	-105	-100	
				Ant: 5720MHz *10	—	-110	-105	
			TRx: 1950MHz State8	Ant: 1760MHz *11	—	-105	-100	
				Ant: 6040MHz *12	—	-112	-105	
		TRx3-Ant	TRx: 835MHz State9	Ant: 790MHz *7	—	-108	-103	
				Ant: 2550MHz *8	—	-110	-105	
			TRx: 1880MHz State9	Ant: 1800MHz *9	—	-105	-100	
				Ant: 5720MHz *10	—	-106	-101	
			TRx: 1950MHz State9	Ant: 1760MHz *11	—	-105	-100	
				Ant: 6040MHz *12	—	-110	-105	
		TRx4-Ant	TRx: 835MHz State10	Ant: 790MHz *7	—	-108	-103	
				Ant: 2550MHz *8	—	-110	-105	
			TRx: 1880MHz State10	Ant: 1800MHz *9	—	-105	-100	
				Ant: 5720MHz *10	—	-105	-100	
			TRx: 1950MHz State10	Ant: 1760MHz *11	—	-105	-100	
				Ant: 6040MHz *12	—	-110	-105	

Electrical characteristics are measured with all RF ports terminated in 50Ω and recommended circuit 2 (SP10T).

- *1 TRx port: +20dBm, 835MHz, Ant port: -15dBm, 45MHz
- *2 TRx port: +20dBm, 835MHz, Ant port: -15dBm, 1715MHz
- *3 TRx port: +20dBm, 1880MHz, Ant port: -15dBm, 80MHz
- *4 TRx port: +20dBm, 1880MHz, Ant port: -15dBm, 3840MHz
- *5 TRx port: +20dBm, 1950MHz, Ant port: -15dBm, 190MHz
- *6 TRx port: +20dBm, 1950MHz, Ant port: -15dBm, 4090MHz
- *7 TRx port: +20dBm, 835MHz, Ant port: -15dBm, 790MHz
- *8 TRx port: +20dBm, 835MHz, Ant port: -15dBm, 2550MHz
- *9 TRx port: +20dBm, 1880MHz, Ant port: -15dBm, 1800MHz
- *10 TRx port: +20dBm, 1880MHz, Ant port: -15dBm, 5720MHz
- *11 TRx port: +20dBm, 1950MHz, Ant port: -15dBm, 1760MHz
- *12 TRx port: +20dBm, 1950MHz, Ant port: -15dBm, 6040MHz

Electrical Characteristics (Recommended Circuit 2 (SP10T))

(V_{DD} = 2.65V, V_{ctl} = 1.80V, T_a = 25°C)

Item	Symbol	Path	Conditions	Min.	Typ.	Max	Unit		
Harmonics	Harm	Tx1-Ant *1	2nd harmonic	1648 to 1698MHz 1780 to 1830MHz	C.W. Pin = +34dBm	—	-49	-36	dBm
			3rd harmonic	2472 to 2547MHz 2670 to 2745MHz		—	-44	-36	
		Tx2-Ant *2	2nd harmonic	3420 to 3570MHz 3700 to 3820MHz	C.W. Pin = +32dBm	—	-53	-36	
			3rd harmonic	5130 to 5355MHz 5550 to 5730MHz		—	-45	-36	
		TRx1-Ant *3	2nd harmonic	3840 to 3960MHz	C.W. Pin = +26dBm	—	-65	-36	
			3rd harmonic	5760 to 5940MHz		—	-63	-36	
		TRx2-Ant *3	2nd harmonic	3840 to 3960MHz	C.W. Pin = +26dBm	—	-65	-36	
			3rd harmonic	5760 to 5940MHz		—	-62	-36	
		TRx3-Ant *3	2nd harmonic	3840 to 3960MHz	C.W. Pin = +26dBm	—	-65	-36	
			3rd harmonic	5760 to 5940MHz		—	-60	-36	
		TRx4-Ant *4	2nd harmonic	1648 to 1698MHz	C.W. Pin = +26dBm	—	-65	-36	
			3rd harmonic	2472 to 2547MHz		—	-65	-36	

Electrical characteristics are measured with all RF ports terminated in 50Ω and recommended circuit 2 (SP10T).

- *1 Frequency = 824 to 915MHz, Pin on Tx1: +34dBm C.W.
- *2 Frequency = 1710 to 1910MHz, Pin on Tx2: +32dBm C.W.
- *3 Frequency = 1920 to 1980MHz, Pin on TRx1 or TRx2 or TRx3: +26dBm C.W.
- *4 Frequency = 824 to 849MHz, Pin on TRx4: +26dBm C.W.



Item	Symbol	Path	Conditions	Min.	Typ.	Max.	Unit	
Attenuation	ATT	Tx1-Ant	1648 to 1830MHz	2fo	25	35	—	dB
			2472 to 2745MHz	3fo	25	35	—	
			3296 to 3660MHz	4fo	20	24	—	
		Tx2-Ant	3420 to 3820MHz	2fo	25	33	—	
			5130 to 5730MHz	3fo	25	32	—	

Item	Symbol	Path	Conditions	Min.	Typ.	Max.	Unit
Switching time	T _s		90% OFF to 90% ON		2	5	μs
Control current	I _{ctl}				—	10	μA
Supply current	I _{DD}		Active mode		0.22	0.4	mA
V.S.W.R.	V.S.W.R.	All ports in active paths	824 to 2170MHz		1.2		—

PCB Layout Template

VQFN-26P-01 Macro (Reference)

- PKG size : 3.8mm × 3.0mm
- Pin pitch : 0.4mm

-  : Land
-  : Mask (Open area)
-  : Resist (Open area)

* Metal mask thickness: 110µm

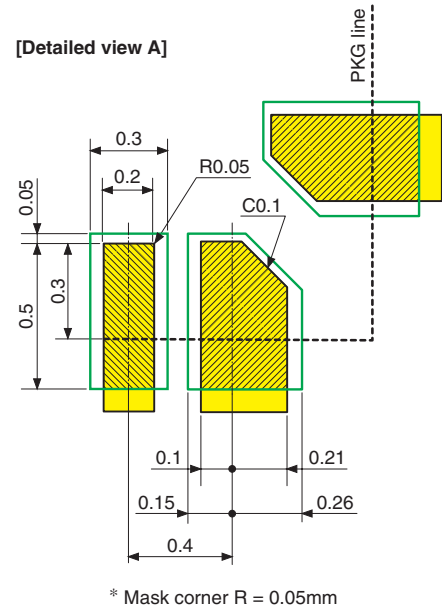
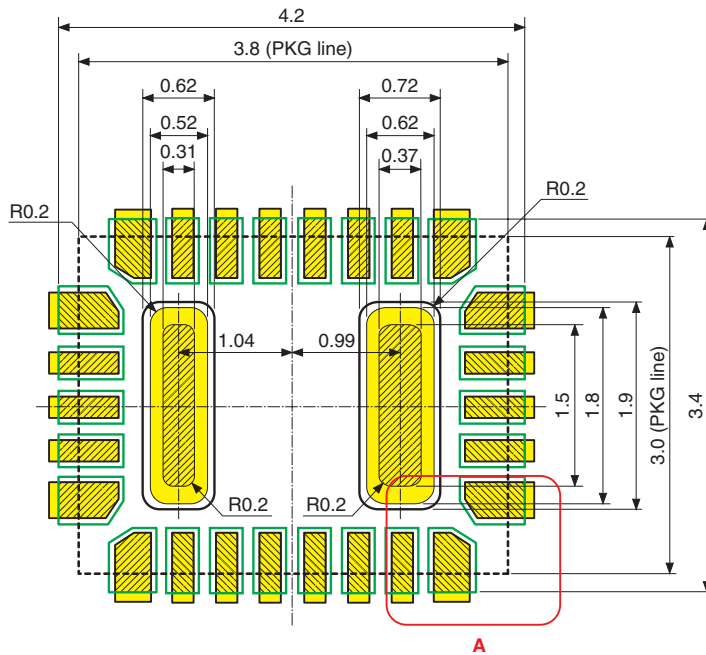

Recommended PCB Design 1 (SP9T)

Ex.) GSM (4 bands) / UMTS (3 bands)

The positions of the light blue via holes and relative GND patterns are strongly recommended for getting stable attenuation.

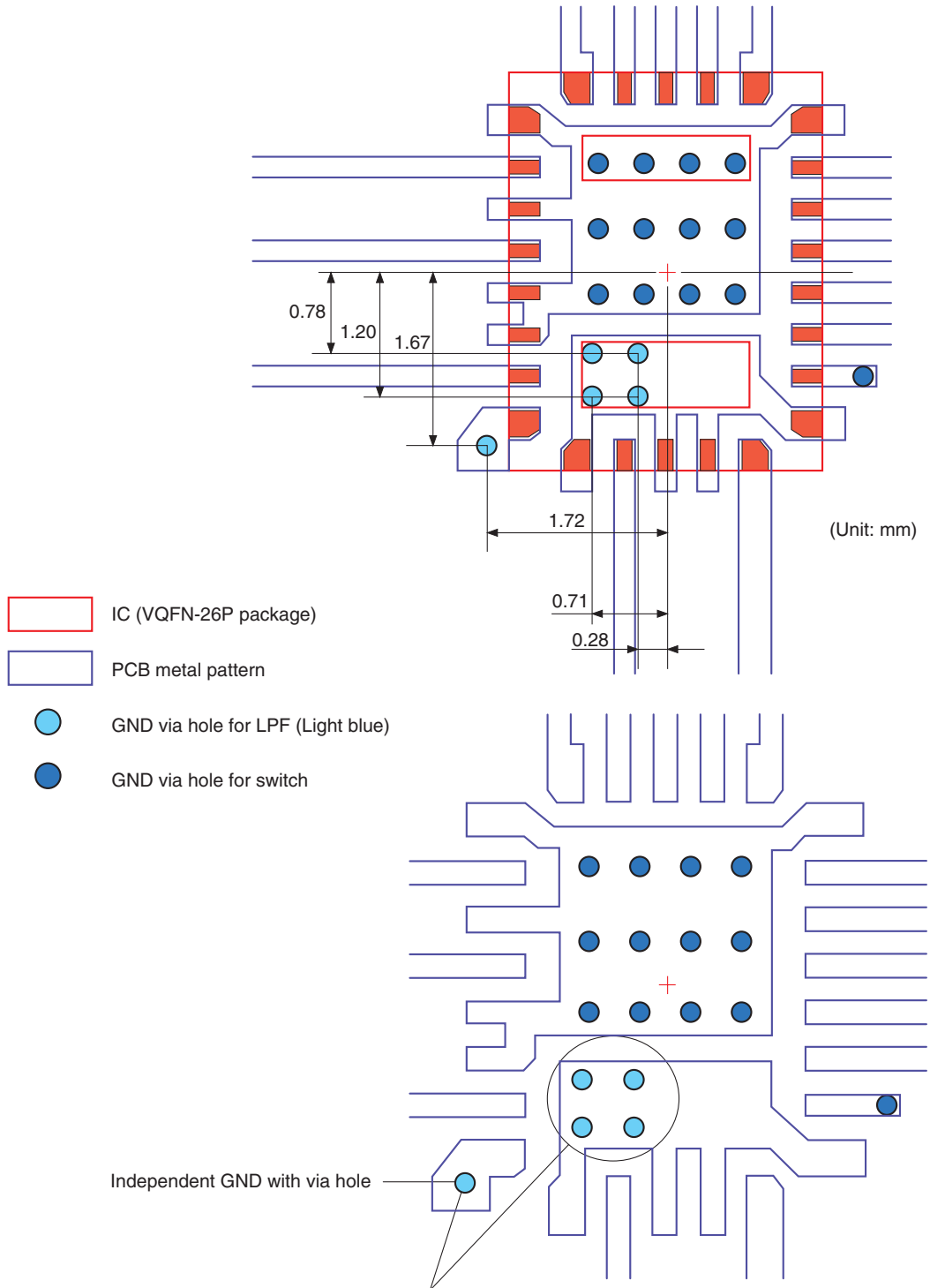

The positions of these via holes are recommended for stable attenuation.

Recommended PCB Design 2 (SP10T)

Ex.) GSM (4 bands) / UMTS (4 bands)

The positions of the light blue via holes and relative GND patterns are strongly recommended for getting stable attenuation.

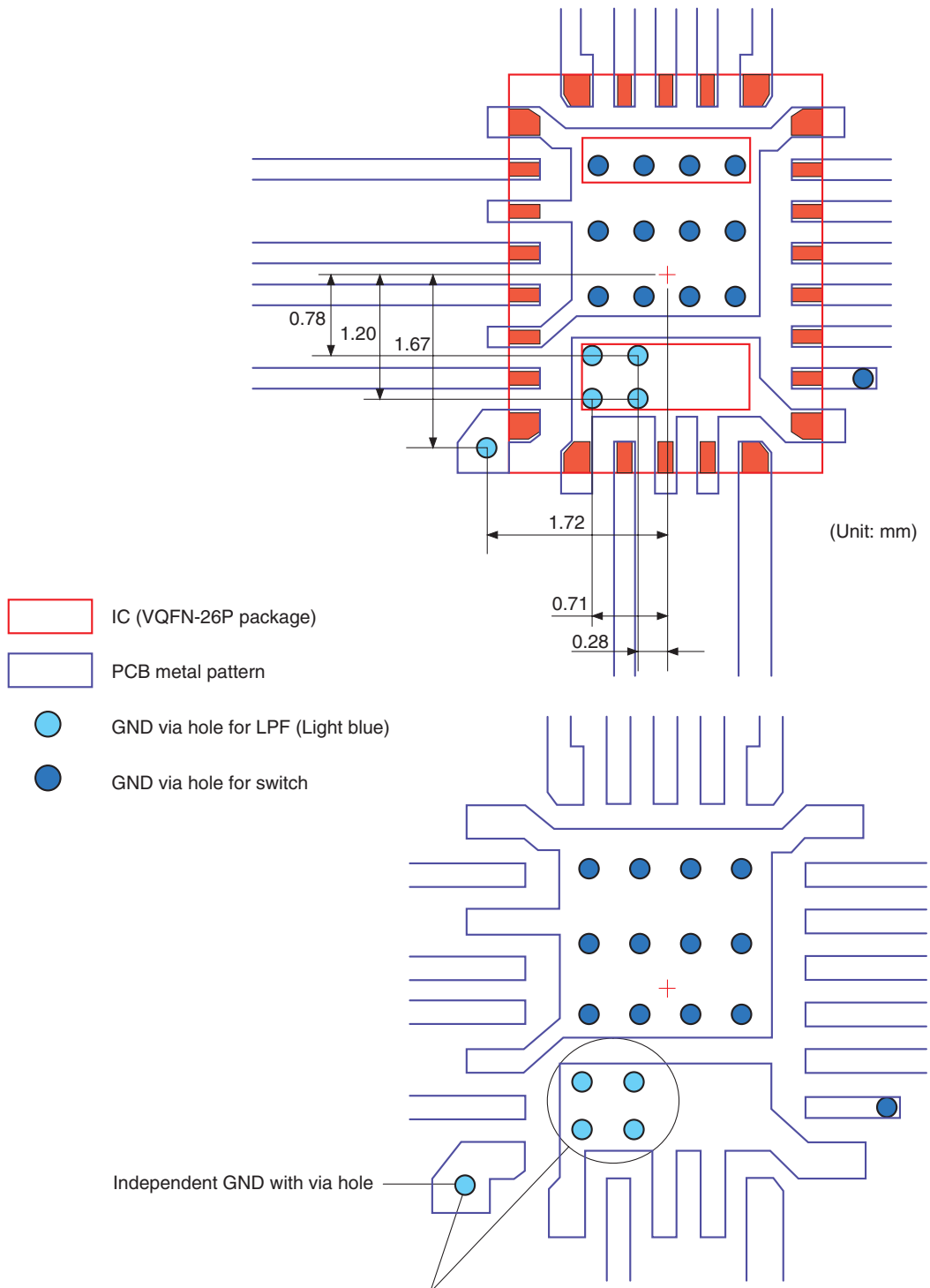

The positions of these via holes are recommended for stable attenuation.

Package Outline

(Unit: mm)

26PIN VQFN (PLASTIC)

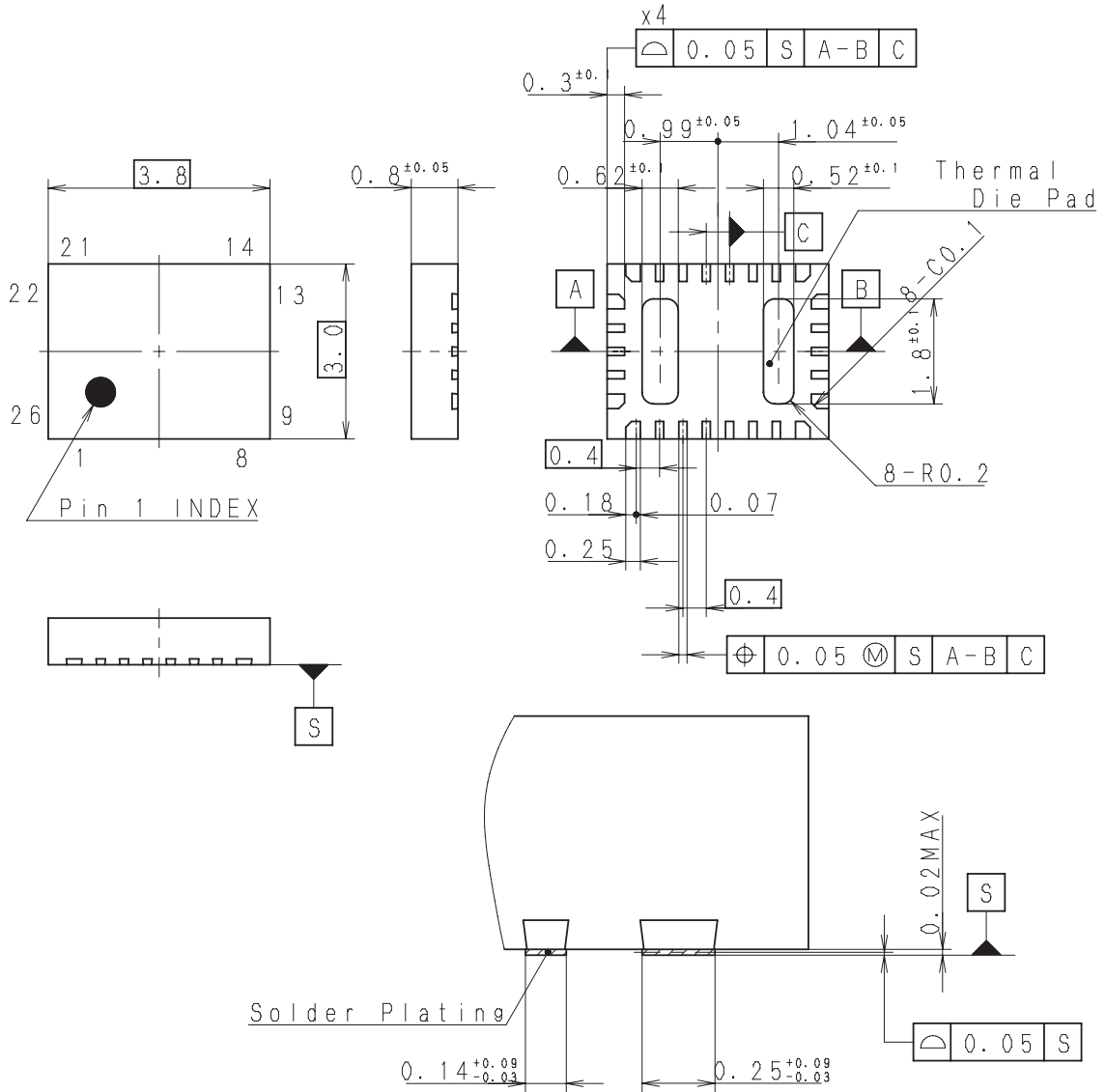

Note:Cutting burr of lead are 0.05mm MAX.

TERMINAL SECTION
PACKAGE STRUCTURE

SONY CODE	VQFN-26P-01
JEITA CODE	—
JEDEC CODE	—

PACKAGE MATERIAL	EPOXY RESIN
TERMINAL TREATMENT	SOLDER PLATING
TERMINAL MATERIAL	COPPER ALLOY
PACKAGE MASS	0.03g

AP-4000-26008S Rev. 0

LEAD PLATING SPECIFICATIONS

ITEM	SPEC.
LEAD MATERIAL	COPPER ALLOY
SOLDER COMPOSITION	Sn-Bi Bi:1-4wt%
PLATING THICKNESS	5-18µm