

CXM3525ER

Description

The CXM3525ER is a DP10T antenna switch module for GSM/UMTS dual mode handset. The CXM3525ER has a built-in dual low pass filter and a +1.8V CMOS compatible decoder. The Sony GaAs junction gate pHEMT (JPHEMT) MMIC process is used for low insertion loss and high linearity. (Applications: GSM /UMTS Dual Mode handsets)

Features

- ◆ Low insertion loss :
 - 1.10dB (Typ.) Tx1 (GSM Low band)
 - 1.05dB (Typ.) Tx2 (GSM High band)
 - 0.40dB (Typ.) UMTS 800M (UMTS Band V)
 - 0.80dB (Typ.) UMTS 2G (UMTS Band I)
- ◆ High attenuation:
 - 25dB (Min.) On Tx1 path @1648-1830MHz
 - 25dB (Min.) On Tx2 path @3420-3820MHz
- ◆ Low voltage operation: $V_{DD} = 2.5V$
- ◆ 1.8V control input
- ◆ No DC blocking capacitors required on RF ports
- ◆ Small package (Size): VQFN-30P (3.4mm × 4.0mm × 0.85mm Max.)
- ◆ Lead-free and RoHS compliant

Package

VQFN-30P (3.4mm × 4.0mm × 0.85mm Max.)

Structure

GaAs JPHEMT MMIC Switch, CMOS Decoder

Note on Handling

This IC is ESD sensitive devices. Special handling precautions are required.

Sony reserves the right to change products and specifications without prior notice. This information does not convey any license by any implication or otherwise under any patents or other right. Application circuits shown, if any, are typical examples illustrating the operation of the devices. Sony cannot assume responsibility for any problems arising out of the use of these circuits.



Absolute Maximum Ratings

◆ Bias voltage	V _{DD}	4	V	(T _a = 25°C)
◆ Control voltage	V _{ctl}	4	V	(T _a = 25°C)
◆ Maximum input	[Tx1]	36	dBm	(Duty cycle = 12.5 to 50%) (T _a = 25°C)
	[Tx2]	34	dBm	(Duty cycle = 12.5 to 50%) (T _a = 25°C)
	[TRx1, 2, 3, 4]	32	dBm	(T _a = 25°C)
	[Rx1, 2, 3, 4]	13	dBm	(T _a = 25°C)
◆ Operating temperature	T _{opr}	-30 to +85	°C	
◆ Storage temperature	T _{stg}	-65 to +150	°C	

Block Diagram

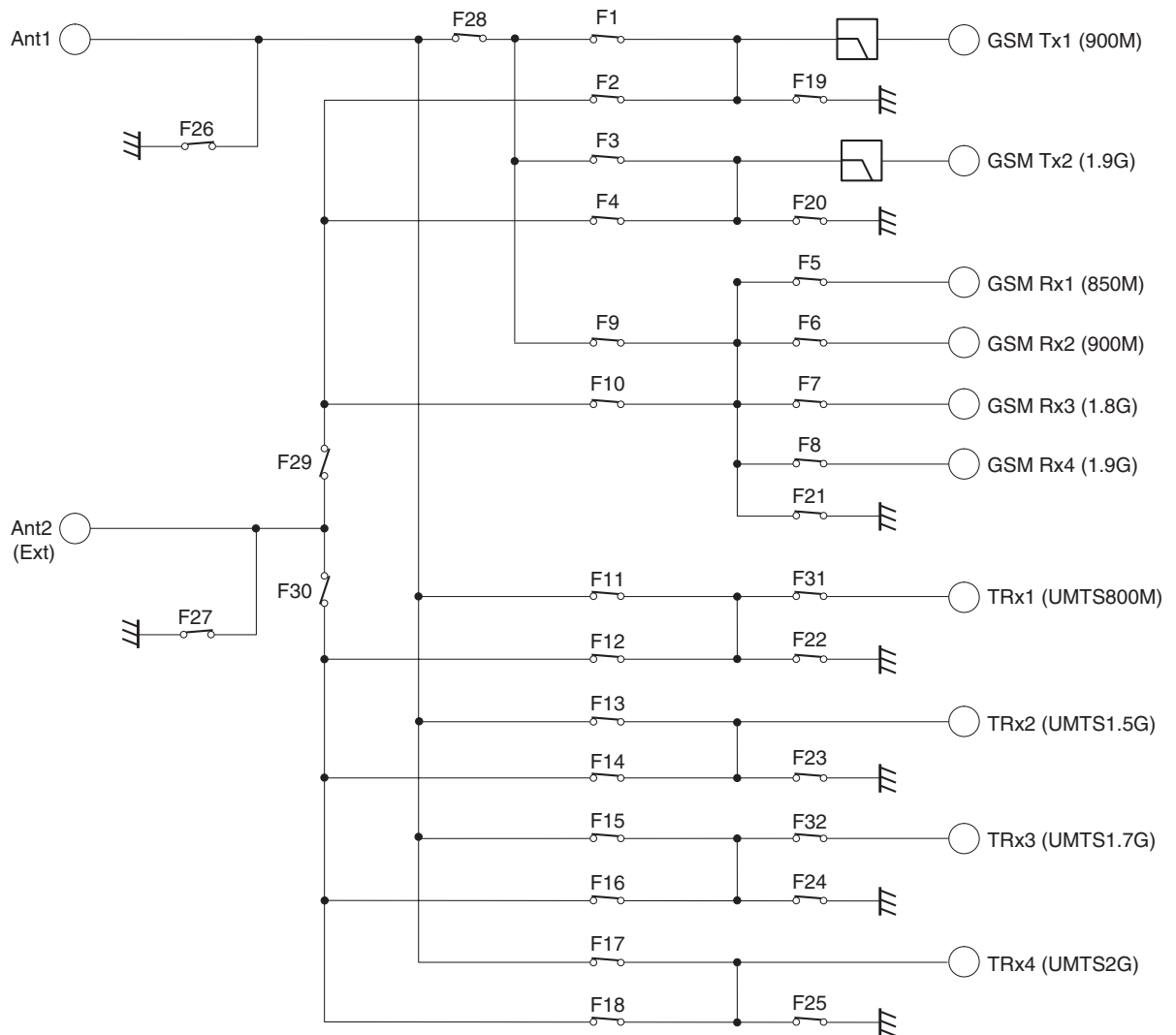

Pin Configuration

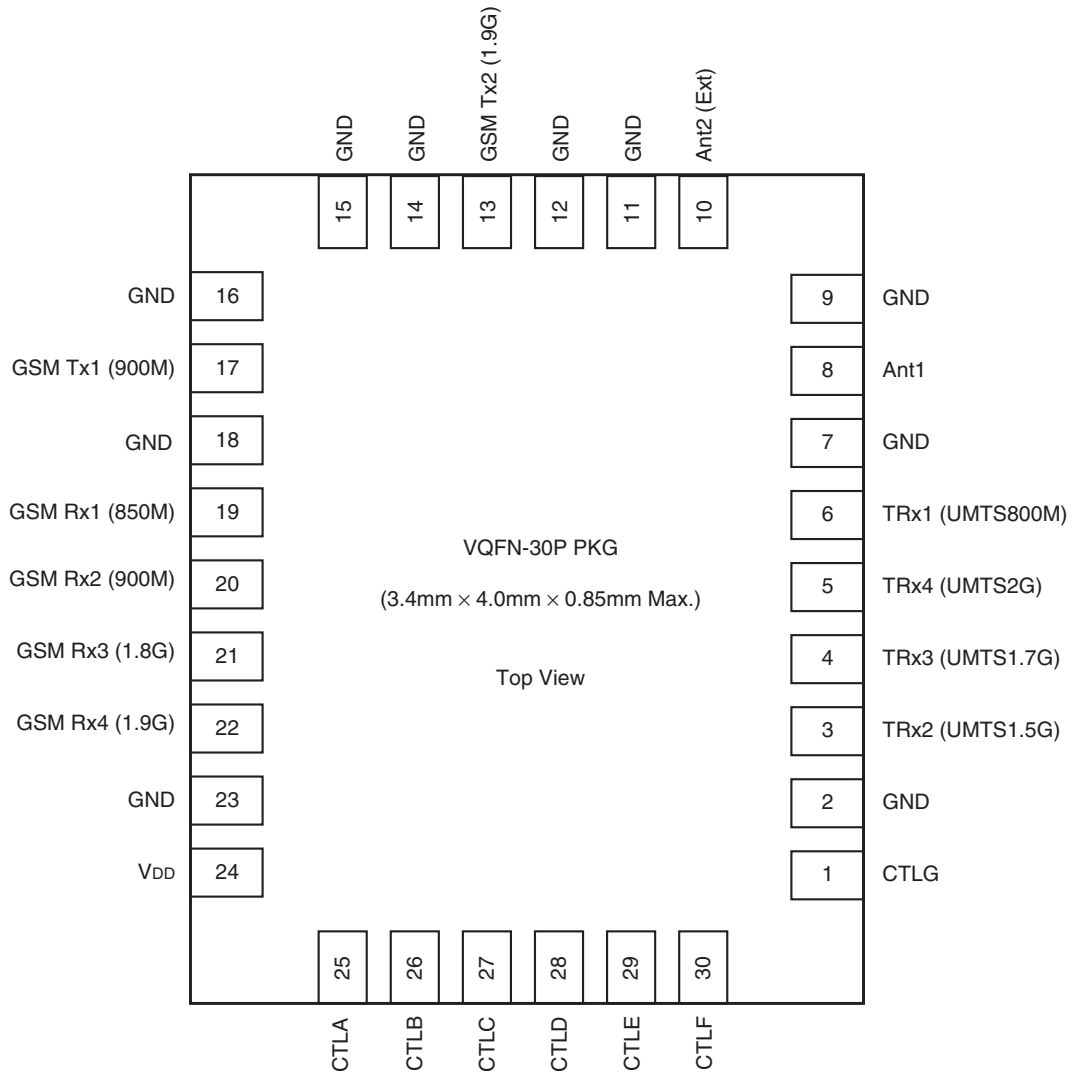

Truth Table

State	GSM/UMTS BAND1	GSM BAND2	GSM Tx/Rx	UMTS BAND1	UMTS BAND2	ANT/EXT	Active Port	Active Ant	F1	F2	F3	F4	F5	F6	F7	F8	F9	F10	F11	F12	F13	F14	F15	F16	F17	F18
1	H	L	L	L	—	—	H	GSM Rx1	ANT1	OFF	OFF	OFF	OFF	ON	OFF	OFF	OFF	ON	OFF	OFF	OFF	OFF	OFF	OFF	OFF	OFF
2	H	L	H	L	—	—	H	GSM Rx2	ANT1	OFF	OFF	OFF	OFF	ON	OFF	OFF	ON	OFF	OFF	OFF	OFF	OFF	OFF	OFF	OFF	OFF
3	H	H	L	L	—	—	H	GSM Rx3	ANT1	OFF	OFF	OFF	OFF	OFF	ON	OFF	ON	OFF	OFF	OFF	OFF	OFF	OFF	OFF	OFF	OFF
4	H	H	H	L	—	—	H	GSM Rx4	ANT1	OFF	OFF	OFF	OFF	OFF	OFF	ON	ON	OFF	OFF	OFF	OFF	OFF	OFF	OFF	OFF	OFF
5	H	L	—	H	—	—	H	GSM Tx1	ANT1	ON	OFF	OFF	OFF	OFF	OFF	OFF	OFF	OFF	OFF	OFF	OFF	OFF	OFF	OFF	OFF	OFF
6	H	H	—	H	—	—	H	GSM Tx2	ANT1	OFF	OFF	ON	OFF	OFF	OFF	OFF	OFF	OFF	OFF	OFF	OFF	OFF	OFF	OFF	OFF	OFF
7	L	—	—	—	L	H	H	TRx1 (UMTS800M)	ANT1	OFF	OFF	OFF	OFF	OFF	OFF	OFF	OFF	OFF	ON	OFF	OFF	OFF	OFF	OFF	OFF	OFF
8	L	—	—	—	H	L	H	TRx2 (UMTS1.5G)	ANT1	OFF	OFF	OFF	OFF	OFF	OFF	OFF	OFF	OFF	OFF	OFF	ON	OFF	OFF	OFF	OFF	OFF
9	L	—	—	—	H	H	H	TRx3 (UMTS1.7G)	ANT1	OFF	OFF	OFF	OFF	OFF	OFF	OFF	OFF	OFF	OFF	OFF	OFF	OFF	ON	OFF	OFF	OFF
10	L	—	—	—	L	L	H	TRx4 (UMTS2G)	ANT1	OFF	OFF	OFF	OFF	OFF	OFF	OFF	OFF	OFF	OFF	OFF	OFF	OFF	OFF	OFF	ON	OFF
11	H	L	L	L	—	—	L	GSM Rx1	ANT2 (EXT)	OFF	OFF	OFF	OFF	ON	OFF	OFF	OFF	ON	OFF	OFF	OFF	OFF	OFF	OFF	OFF	OFF
12	H	L	H	L	—	—	L	GSM Rx2	ANT2 (EXT)	OFF	OFF	OFF	OFF	OFF	ON	OFF	OFF	ON	OFF	OFF	OFF	OFF	OFF	OFF	OFF	OFF
13	H	H	L	L	—	—	L	GSM Rx3	ANT2 (EXT)	OFF	OFF	OFF	OFF	OFF	ON	OFF	OFF	ON	OFF	OFF	OFF	OFF	OFF	OFF	OFF	OFF
14	H	H	H	L	—	—	L	GSM Rx4	ANT2 (EXT)	OFF	OFF	OFF	OFF	OFF	OFF	ON	OFF	ON	OFF	OFF	OFF	OFF	OFF	OFF	OFF	OFF
15	H	L	—	H	—	—	L	GSM Tx1	ANT2 (EXT)	OFF	ON	OFF	OFF	OFF	OFF	OFF	OFF	OFF	OFF	OFF	OFF	OFF	OFF	OFF	OFF	OFF
16	H	H	—	H	—	—	L	GSM Tx2	ANT2 (EXT)	OFF	OFF	OFF	ON	OFF	OFF	OFF	OFF	OFF	OFF	OFF	OFF	OFF	OFF	OFF	OFF	OFF
17	L	—	—	—	L	H	L	TRx1 (UMTS800M)	ANT2 (EXT)	OFF	OFF	OFF	OFF	OFF	OFF	OFF	OFF	OFF	ON	OFF	OFF	OFF	OFF	OFF	OFF	OFF
18	L	—	—	—	H	L	L	TRx2 (UMTS1.5G)	ANT2 (EXT)	OFF	OFF	OFF	OFF	OFF	OFF	OFF	OFF	OFF	OFF	OFF	OFF	ON	OFF	OFF	OFF	OFF
19	L	—	—	—	H	H	L	TRx3 (UMTS1.7G)	ANT2 (EXT)	OFF	OFF	OFF	OFF	OFF	OFF	OFF	OFF	OFF	OFF	OFF	OFF	OFF	OFF	ON	OFF	OFF
20	L	—	—	—	L	L	L	TRx4 (UMTS2G)	ANT2 (EXT)	OFF	OFF	OFF	OFF	OFF	OFF	OFF	OFF	OFF	OFF	OFF	OFF	OFF	OFF	OFF	OFF	ON

State	GSM/UMTS BAND1	GSM BAND2	GSM Tx/Rx	UMTS BAND1	UMTS BAND2	ANT/EXT	Active Port	Active Ant	F19	F20	F21	F22	F23	F24	F25	F26	F27	F27	F29	F30	F31	F32		
1	H	L	L	L	—	—	H	GSM Rx1	ANT1	ON	ON	OFF	ON	ON	ON	ON	OFF	ON	ON	ON	OFF	ON	ON	
2	H	L	H	L	—	—	H	GSM Rx2	ANT1	ON	ON	OFF	ON	ON	ON	ON	OFF	ON	ON	ON	OFF	ON	ON	
3	H	H	L	L	—	—	H	GSM Rx3	ANT1	ON	ON	OFF	ON	ON	ON	ON	OFF	ON	ON	ON	OFF	ON	ON	
4	H	H	H	L	—	—	H	GSM Rx4	ANT1	ON	ON	OFF	ON	ON	ON	ON	OFF	ON	ON	ON	OFF	ON	ON	
5	H	L	—	H	—	—	H	GSM Tx1	ANT1	OFF	ON	ON	ON	ON	ON	ON	OFF	ON	ON	ON	OFF	OFF	ON	
6	H	H	—	H	—	—	H	GSM Tx2	ANT1	ON	OFF	ON	ON	ON	ON	ON	OFF	ON	ON	ON	OFF	ON	OFF	
7	L	—	—	—	L	H	H	TRx1 (UMTS800M)	ANT1	ON	ON	ON	OFF	ON	ON	ON	OFF	ON	OFF	OFF	OFF	ON	ON	ON
8	L	—	—	—	H	L	H	TRx2 (UMTS1.5G)	ANT1	ON	ON	ON	ON	OFF	ON	ON	OFF	ON	OFF	OFF	OFF	ON	ON	ON
9	L	—	—	—	H	H	H	TRx3 (UMTS1.7G)	ANT1	ON	ON	ON	ON	ON	OFF	ON	OFF	ON	OFF	OFF	OFF	ON	ON	ON
10	L	—	—	—	L	L	H	TRx4 (UMTS2G)	ANT1	ON	ON	ON	ON	ON	ON	OFF	OFF	ON	OFF	OFF	OFF	ON	ON	ON
11	H	L	L	L	—	—	L	GSM Rx1	ANT2 (EXT)	ON	ON	OFF	ON	ON	ON	ON	ON	OFF	ON	ON	OFF	ON	ON	ON
12	H	L	H	L	—	—	L	GSM Rx2	ANT2 (EXT)	ON	ON	OFF	ON	ON	ON	ON	ON	OFF	ON	ON	OFF	ON	ON	ON
13	H	H	L	L	—	—	L	GSM Rx3	ANT2 (EXT)	ON	ON	OFF	ON	ON	ON	ON	ON	OFF	ON	ON	OFF	ON	ON	ON
14	H	H	H	L	—	—	L	GSM Rx4	ANT2 (EXT)	ON	ON	OFF	ON	ON	ON	ON	ON	OFF	ON	ON	OFF	ON	ON	ON
15	H	L	—	H	—	—	L	GSM Tx1	ANT2 (EXT)	OFF	ON	ON	ON	ON	ON	ON	ON	OFF	ON	ON	OFF	OFF	ON	ON
16	H	H	—	H	—	—	L	GSM Tx2	ANT2 (EXT)	ON	OFF	ON	ON	ON	ON	ON	ON	OFF	ON	ON	OFF	ON	OFF	ON
17	L	—	—	—	L	H	L	TRx1 (UMTS800M)	ANT2 (EXT)	ON	ON	ON	OFF	ON	ON	ON	ON	OFF	OFF	OFF	OFF	ON	ON	ON
18	L	—	—	—	H	L	L	TRx2 (UMTS1.5G)	ANT2 (EXT)	ON	ON	ON	ON	OFF	ON	ON	ON	OFF	OFF	OFF	OFF	ON	ON	ON
19	L	—	—	—	H	H	L	TRx3 (UMTS1.7G)	ANT2 (EXT)	ON	ON	ON	ON	ON	OFF	ON	ON	OFF	OFF	OFF	OFF	ON	ON	ON
20	L	—	—	—	L	L	L	TRx4 (UMTS2G)	ANT2 (EXT)	ON	ON	ON	ON	ON	ON	OFF	ON	OFF	OFF	OFF	OFF	ON	ON	ON

Electrical Characteristics

DC Bias Conditions

(Ta = 25°C)

Symbol	Min.	Typ.	Max.	Unit
V _{DD}	2.5	2.8	3.3	V
V _{ctl} (H)	1.5	1.8	3.3	V
V _{ctl} (L)	0	—	0.3	V

(Ta = 25°C)

Item	Symbol	Conditions	Min.	Typ.	Max.	Unit
Switching time	T _{sw}		—	3	5	μs
Start up time	T _{st}	V _{DD} = 0 to 2.8V	—	6	50	μs
Control current	I _{ctl}		—	0.01	5	μA
Supply current	I _{DD}	Active mode (V _{DD} = 2.8V)	—	0.30	0.45	mA

(V_{DD} = 2.8V, V_{ctl} = 1.8V/0V)

Item	Symbol	Path	Condition	Ant Active			Ext Active			Unit
				Min.	Typ.	Max.	Min.	Typ.	Max.	
Insertion loss	IL	Ant/Ext-Tx1	*1	—	1.10	1.25	—	1.10	1.25	dB
		Ant/Ext-Tx2	*2	—	1.05	1.20	—	1.05	1.20	
		Ant/Ext-Rx1	*3	—	1.07	1.22	—	1.03	1.18	
		Ant/Ext-Rx2	*3	—	1.10	1.25	—	1.05	1.20	
		Ant/Ext-Rx3	*4	—	1.35	1.50	—	1.25	1.40	
		Ant/Ext-Rx4	*4	—	1.40	1.55	—	1.20	1.35	
		Ant/Ext-TRx1	*5	—	0.40	0.55	—	0.50	0.65	
		Ant/Ext-TRx2	*6	—	0.45	0.60	—	0.60	0.75	
		Ant/Ext-TRx3	*7	—	0.65	0.80	—	0.83	0.98	
Ant/Ext-TRx4	*8	—	0.80	0.95	—	0.90	1.05			
VSWR	VSWR	All ports in active paths	824 to 2170MHz	—	1.2	—	—	1.2	—	
Rx band spurious	SPR	Ant/Ext-Rx1, 2, 3, 4	*3, *4		—	-125		—	-125	dBm
Attenuation	ATT	Tx1-Ant/Ext	1648 to 1830MHz	25	32	—	25	30	—	dB
			2472 to 2745MHz	25	36	—	25	33	—	
			3296 to 3660MHz	20	28	—	20	28	—	
		Tx2-Ant/Ext	3420 to 3820MHz	25	33	—	24	30	—	
			5130 to 5730MHz	25	31	—	24	29	—	

Electrical characteristics are measured with all RF ports terminated in 50Ω.

Item	Symbol	Path	Condition	Ant Active			Ext Active			Unit
				Min.	Typ.	Max.	Min.	Typ.	Max.	
Harmonics***	2fo	Tx1-Ant/Ext	*1	—	-46	-36	—	-43	-36	dBm
	3fo			—	-44	-36	—	-44	-36	
	2fo	Tx2-Ant/Ext	*2	—	-52	-36	—	-50	-36	
	3fo			—	-47	-36	—	-47	-36	
	2fo	TRx1-Ant/Ext	*5	—	-68	-36	—	-63	-36	
	3fo			—	-65	-36	—	-65	-36	
	2fo	TRx2-Ant/Ext	*6	—	-63	-36	—	-63	-36	
	3fo			—	-65	-36	—	-65	-36	
	2fo	TRx3-Ant/Ext	*7	—	-68	-36	—	-63	-36	
	3fo			—	-65	-36	—	-65	-36	
2fo	TRx4-Ant/Ext	*8	—	-67	-36	—	-63	-36		
3fo			—	-65	-36	—	-65	-36		
ACLR***	±5MHz	TRx1-Ant/Ext	*5	—	—	-50	—	—	-50	dBc
	±10MHz			—	—	-55	—	—	-55	
	±5MHz	TRx2-Ant/Ext	*6	—	—	-50	—	—	-50	
	±10MHz			—	—	-55	—	—	-55	
	±5MHz	TRx3-Ant/Ext	*7	—	—	-50	—	—	-50	
	±10MHz			—	—	-55	—	—	-55	
	±5MHz	TRx4-Ant/Ext	*8	—	—	-50	—	—	-50	
	±10MHz			—	—	-55	—	—	-55	

Electrical characteristics are measured with all RF ports terminated in 50Ω.

- *1 Pin on Tx1: 35dBm, 824 to 915MHz, V_{DD} = 2.8V, Tx1 enabled
- *2 Pin on Tx2: 32dBm, 1710 to 1910MHz, V_{DD} = 2.8V, Tx2 enabled
- *3 Pin on Ant: 10dBm, 869 to 960MHz, V_{DD} = 2.8V, Rx1 or Rx2 enabled
- *4 Pin on Ant: 10dBm, 1805 to 1990MHz, V_{DD} = 2.8V, Rx3 or Rx4 enabled
- *5 Pin on TRx1: 26dBm, 824 to 894MHz, V_{DD} = 2.8V, TRx1 enabled
- *6 Pin on TRx2: 26dBm, 1428 to 1496MHz, V_{DD} = 2.8V, TRx2 enabled
- *7 Pin on TRx3: 26dBm, 1750 to 1880MHz, V_{DD} = 2.8V, TRx3 enabled
- *8 Pin on TRx4: 26dBm, 1920 to 2170MHz, V_{DD} = 2.8V, TRx4 enabled

Item	Symbol	Path	Condition	Min.	Typ.	Max.	Unit
Isolation	ISO1	Tx1-Rx1, 2, 3, 4	Tx1-Ant/Ext Active Freq. = Tx1_Band	30	54	—	dB
		Tx1-TRx2, 3, 4	Tx1-Ant/Ext Active Freq. = Tx1_Band	25	33	—	
		Tx1-TRx1	Tx1-Ant/Ext Active Freq. = Tx1_Band	30	49	—	
		Tx2-Rx1, 2, 3, 4	Tx2-Ant/Ext Active Freq. = Tx2_Band	30	54	—	
		Tx2-TRx1, 2, 4	Tx2-Ant/Ext Active Freq. = Tx2_Band	17	21	—	
		Tx2-TRx3	Tx2-Ant/Ext Active Freq. = Tx2_Band	25	32	—	
	ISO2	Tx1-Ant	Rx1, 2 Active Freq. = Tx1_Band	25	31	—	
		Tx1-Ext	Rx1, 2 Active Freq. = Tx1_Band	25	33	—	
		Tx2-Ant	Rx3, 4 Active Freq. = Tx2_Band	20	24	—	
		Tx2-Ext	Rx3, 4 Active Freq. = Tx2_Band	20.5	24.5	—	
ISO3	Tx1-Tx2	Tx1 Active Freq. = Tx1_Band	17	20	—		
		Tx2 Active Freq. = Tx2_Band	20	24	—		

Item	Symbol	Path	Condition	Ant Active			Ext Active			Unit
				Min.	Typ.	Max.	Min.	Typ.	Max.	
Intermodulation distortion level in Rx band	IMD2	TRx1-Ant/Ext	*9, *25	—	-124	-110	—	-124	-110	dBm
			*10, *25	—	-120	-110	—	-116	-106	
		TRx2-Ant/Ext	*11, *25	—	-119	-109	—	-120	-110	
			*12, *25	—	-111	-105	—	-111	-105	
		TRx3-Ant/Ext	*13, *25	—	-111	-105	—	-111	-105	
			*14, *25	—	-118	-108	—	-107	-102	
		TRx4-Ant/Ext	*15, *25	—	-106	-102	—	-106	-102	
			*16, *25	—	-110	-105	—	-113	-105	
	IMD3	TRx1-Ant/Ext	*17, *25	—	-111	-105	—	-109	-105	
			*18, *25	—	-114	-105	—	-111	-105	
		TRx2-Ant/Ext	*19, *25	—	-110	-105	—	-108	-104	
			*20, *25	—	-112	-105	—	-108	-103	
		TRx3-Ant/Ext	*21, *25	—	-108	-104	—	-109	-105	
			*22, *25	—	-115	-105	—	-108	-103	
		TRx4-Ant/Ext	*23, *25	—	-110	-105	—	-109	-105	
			*24, *25	—	-116	-106	—	-114	-105	

Electrical characteristics are measured with all RF ports terminated in 50Ω.

- *9 TRx port: 21.5dBm, 835MHz, Ant port: -15dBm, 45MHz, V_{DD} = 2.8V
- *10 TRx port: 21.5dBm, 835MHz, Ant port: -15dBm, 1715MHz, V_{DD} = 2.8V
- *11 TRx port: 21.5dBm, 1438MHz, Ant port: -15dBm, 48MHz, V_{DD} = 2.8V
- *12 TRx port: 21.5dBm, 1438MHz, Ant port: -15dBm, 2924MHz, V_{DD} = 2.8V
- *13 TRx port: 21.5dBm, 1765MHz, Ant port: -15dBm, 95MHz, V_{DD} = 2.8V
- *14 TRx port: 21.5dBm, 1765MHz, Ant port: -15dBm, 3625MHz, V_{DD} = 2.8V
- *15 TRx port: 21.5dBm, 1950MHz, Ant port: -15dBm, 190MHz, V_{DD} = 2.8V
- *16 TRx port: 21.5dBm, 1950MHz, Ant port: -15dBm, 4090MHz, V_{DD} = 2.8V
- *17 TRx port: 21.5dBm, 835MHz, Ant port: -15dBm, 790MHz, V_{DD} = 2.8V
- *18 TRx port: 21.5dBm, 835MHz, Ant port: -15dBm, 2550MHz, V_{DD} = 2.8V
- *19 TRx port: 21.5dBm, 1438MHz, Ant port: -15dBm, 1390MHz, V_{DD} = 2.8V
- *20 TRx port: 21.5dBm, 1438MHz, Ant port: -15dBm, 4362MHz, V_{DD} = 2.8V
- *21 TRx port: 21.5dBm, 1765MHz, Ant port: -15dBm, 1670MHz, V_{DD} = 2.8V
- *22 TRx port: 21.5dBm, 1765MHz, Ant port: -15dBm, 5390MHz, V_{DD} = 2.8V
- *23 TRx port: 21.5dBm, 1950MHz, Ant port: -15dBm, 1760MHz, V_{DD} = 2.8V
- *24 TRx port: 21.5dBm, 1950MHz, Ant port: -15dBm, 6040MHz, V_{DD} = 2.8V
- *25 Measured with recommended circuit

DC Bias Conditions

(Ta = -30 to +85°C)

Symbol	Min.	Typ.	Max.	Unit
V _{DD}	2.5	2.8	3.3	V
V _{ctl} (H)	1.5	1.8	3.3	V
V _{ctl} (L)	0	—	0.3	V

(Ta = -30 to +85°C)

Item	Symbol	Conditions	Min.	Typ.	Max.	Unit
Switching time	T _{sw}		—	3	5	μs
Start up time	T _{st}	V _{DD} = 0 to 2.8V	—	6	50	μs
Control current	I _{ctl}		—	0.01	5	μA
Supply current	I _{DD}	Active mode (V _{DD} = 2.8V)	—	0.30	0.60	mA

(V_{DD} = 2.8V, V_{ctl} = 1.8V/0V)

Item	Symbol	Path	Condition	Ant Active			Ext Active			Unit
				Min.	Typ.	Max.	Min.	Typ.	Max.	
Insertion loss	IL	Ant/Ext-Tx1	*1	—	—	1.35	—	—	1.35	dB
		Ant/Ext-Tx2	*2	—	—	1.30	—	—	1.30	
		Ant/Ext-Rx1	*3	—	—	1.32	—	—	1.28	
		Ant/Ext-Rx2	*3	—	—	1.35	—	—	1.30	
		Ant/Ext-Rx3	*4	—	—	1.60	—	—	1.50	
		Ant/Ext-Rx4	*4	—	—	1.65	—	—	1.45	
		Ant/Ext-TRx1	*5	—	—	0.65	—	—	0.75	
		Ant/Ext-TRx2	*6	—	—	0.70	—	—	0.85	
		Ant/Ext-TRx3	*7	—	—	0.90	—	—	1.08	
		Ant/Ext-TRx4	*8	—	—	1.05	—	—	1.15	
VSWR	VSWR	All ports in active paths	824 to 2170MHz	—	1.2	—	—	1.2	—	—
Rx band spurious	SPR	Ant/Ext-Rx1, 2, 3, 4	*3, *4		—	-125		—	-125	dBm
Attenuation	ATT	Tx1-Ant/Ext	1648 to 1830MHz	25	—	—	25	—	—	dB
			2472 to 2745MHz	25	—	—	25	—	—	
			3296 to 3660MHz	20	—	—	20	—	—	
		Tx2-Ant/Ext	3420 to 3820MHz	25	—	—	24	—	—	
			5130 to 5730MHz	25	—	—	24	—	—	

Electrical characteristics are measured with all RF ports terminated in 50Ω.

Item	Symbol	Path	Condition	Ant Active			Ext Active			Unit
				Min.	Typ.	Max.	Min.	Typ.	Max.	
Harmonics***	2fo	Tx1-Ant/Ext	*1	—	—	-33	—	—	-33	dBm
	3fo			—	—	-33	—	—	-33	
	2fo	Tx2-Ant/Ext	*2	—	—	-33	—	—	-33	
	3fo			—	—	-33	—	—	-33	
	2fo	TRx1-Ant/Ext	*5	—	—	-36	—	—	-36	
	3fo			—	—	-36	—	—	-36	
	2fo	TRx2-Ant/Ext	*6	—	—	-36	—	—	-36	
	3fo			—	—	-36	—	—	-36	
	2fo	TRx3-Ant/Ext	*7	—	—	-36	—	—	-36	
	3fo			—	—	-36	—	—	-36	
2fo	TRx4-Ant/Ext	*8	—	—	-36	—	—	-36		
3fo			—	—	-36	—	—	-36		
ACLR***	±5MHz	TRx1-Ant/Ext	*5	—	—	-50	—	—	-50	dBc
	±10MHz			—	—	-55	—	—	-55	
	±5MHz	TRx2-Ant/Ext	*6	—	—	-50	—	—	-50	
	±10MHz			—	—	-55	—	—	-55	
	±5MHz	TRx3-Ant/Ext	*7	—	—	-50	—	—	-50	
	±10MHz			—	—	-55	—	—	-55	
	±5MHz	TRx4-Ant/Ext	*8	—	—	-50	—	—	-50	
	±10MHz			—	—	-55	—	—	-55	

Electrical characteristics are measured with all RF ports terminated in 50Ω.

- *1 Pin on Tx1: 35dBm, 824 to 915MHz, V_{DD} = 2.8V, Tx1 enabled
- *2 Pin on Tx2: 32dBm, 1710 to 1910MHz, V_{DD} = 2.8V, Tx2 enabled
- *3 Pin on Ant: 10dBm, 869 to 960MHz, V_{DD} = 2.8V, Rx1 or Rx2 enabled
- *4 Pin on Ant: 10dBm, 1805 to 1990MHz, V_{DD} = 2.8V, Rx3 or Rx4 enabled
- *5 Pin on TRx1: 26dBm, 824 to 894MHz, V_{DD} = 2.8V, TRx1 enabled
- *6 Pin on TRx2: 26dBm, 1428 to 1496MHz, V_{DD} = 2.8V, TRx2 enabled
- *7 Pin on TRx3: 26dBm, 1750 to 1880MHz, V_{DD} = 2.8V, TRx3 enabled
- *8 Pin on TRx4: 26dBm, 1920 to 2170MHz, V_{DD} = 2.8V, TRx4 enabled

Item	Symbol	Path	Condition	Min.	Typ.	Max.	Unit
Isolation	ISO1	Tx1-Rx1, 2, 3, 4	Tx1-Ant/Ext Active Freq. = Tx1_Band	30	—	—	dB
		Tx1-TRx2, 3, 4	Tx1-Ant/Ext Active Freq. = Tx1_Band	25	—	—	
		Tx1-TRx1	Tx1-Ant/Ext Active Freq. = Tx1_Band	30	—	—	
		Tx2-Rx1, 2, 3, 4	Tx2-Ant/Ext Active Freq. = Tx2_Band	30	—	—	
		Tx2-TRx1, 2, 4	Tx2-Ant/Ext Active Freq. = Tx2_Band	14	—	—	
		Tx2-TRx3	Tx2-Ant/Ext Active Freq. = Tx2_Band	25	—	—	
	ISO2	Tx1-Ant	Rx1, 2 Active Freq. = Tx1_Band	25	—	—	
		Tx1-Ext	Rx1, 2 Active Freq. = Tx1_Band	25	—	—	
		Tx2-Ant	Rx3, 4 Active Freq. = Tx2_Band	17	—	—	
		Tx2-Ext	Rx3, 4 Active Freq. = Tx2_Band	17.5	—	—	
ISO3	Tx1-Tx2	Tx1 Active Freq. = Tx1_Band	16	—	—		
		Tx2 Active Freq. = Tx2_Band	19	—	—		

Item	Symbol	Path	Condition	Ant Active			Ext Active			Unit
				Min.	Typ.	Max.	Min.	Typ.	Max.	
Intermodulation distortion level in Rx band	IMD2	TRx1-Ant/Ext	*9, *25	—	—	-107	—	—	-107	dBm
			*10, *25	—	—	-107	—	—	-103	
		TRx2-Ant/Ext	*11, *25	—	—	-106	—	—	-107	
			*12, *25	—	—	-102	—	—	-102	
		TRx3-Ant/Ext	*13, *25	—	—	-102	—	—	-102	
			*14, *25	—	—	-105	—	—	-99	
	TRx4-Ant/Ext	*15, *25	—	—	-99	—	—	-99		
		*16, *25	—	—	-102	—	—	-102		
	IMD3	TRx1-Ant/Ext	*17, *25	—	—	-102	—	—	-102	
			*18, *25	—	—	-102	—	—	-102	
		TRx2-Ant/Ext	*19, *25	—	—	-102	—	—	-101	
			*20, *25	—	—	-102	—	—	-100	
		TRx3-Ant/Ext	*21, *25	—	—	-101	—	—	-102	
			*22, *25	—	—	-102	—	—	-100	
		TRx4-Ant/Ext	*23, *25	—	—	-102	—	—	-102	
			*24, *25	—	—	-103	—	—	-102	

Electrical characteristics are measured with all RF ports terminated in 50Ω.

- *9 TRx port: 21.5dBm, 835MHz, Ant port: -15dBm, 45MHz, V_{DD} = 2.8V
- *10 TRx port: 21.5dBm, 835MHz, Ant port: -15dBm, 1715MHz, V_{DD} = 2.8V
- *11 TRx port: 21.5dBm, 1438MHz, Ant port: -15dBm, 48MHz, V_{DD} = 2.8V
- *12 TRx port: 21.5dBm, 1438MHz, Ant port: -15dBm, 2924MHz, V_{DD} = 2.8V
- *13 TRx port: 21.5dBm, 1765MHz, Ant port: -15dBm, 95MHz, V_{DD} = 2.8V
- *14 TRx port: 21.5dBm, 1765MHz, Ant port: -15dBm, 3625MHz, V_{DD} = 2.8V
- *15 TRx port: 21.5dBm, 1950MHz, Ant port: -15dBm, 190MHz, V_{DD} = 2.8V
- *16 TRx port: 21.5dBm, 1950MHz, Ant port: -15dBm, 4090MHz, V_{DD} = 2.8V
- *17 TRx port: 21.5dBm, 835MHz, Ant port: -15dBm, 790MHz, V_{DD} = 2.8V
- *18 TRx port: 21.5dBm, 835MHz, Ant port: -15dBm, 2550MHz, V_{DD} = 2.8V
- *19 TRx port: 21.5dBm, 1438MHz, Ant port: -15dBm, 1390MHz, V_{DD} = 2.8V
- *20 TRx port: 21.5dBm, 1438MHz, Ant port: -15dBm, 4362MHz, V_{DD} = 2.8V
- *21 TRx port: 21.5dBm, 1765MHz, Ant port: -15dBm, 1670MHz, V_{DD} = 2.8V
- *22 TRx port: 21.5dBm, 1765MHz, Ant port: -15dBm, 5390MHz, V_{DD} = 2.8V
- *23 TRx port: 21.5dBm, 1950MHz, Ant port: -15dBm, 1760MHz, V_{DD} = 2.8V
- *24 TRx port: 21.5dBm, 1950MHz, Ant port: -15dBm, 6040MHz, V_{DD} = 2.8V
- *25 Measured with recommended circuit

Recommended Circuit

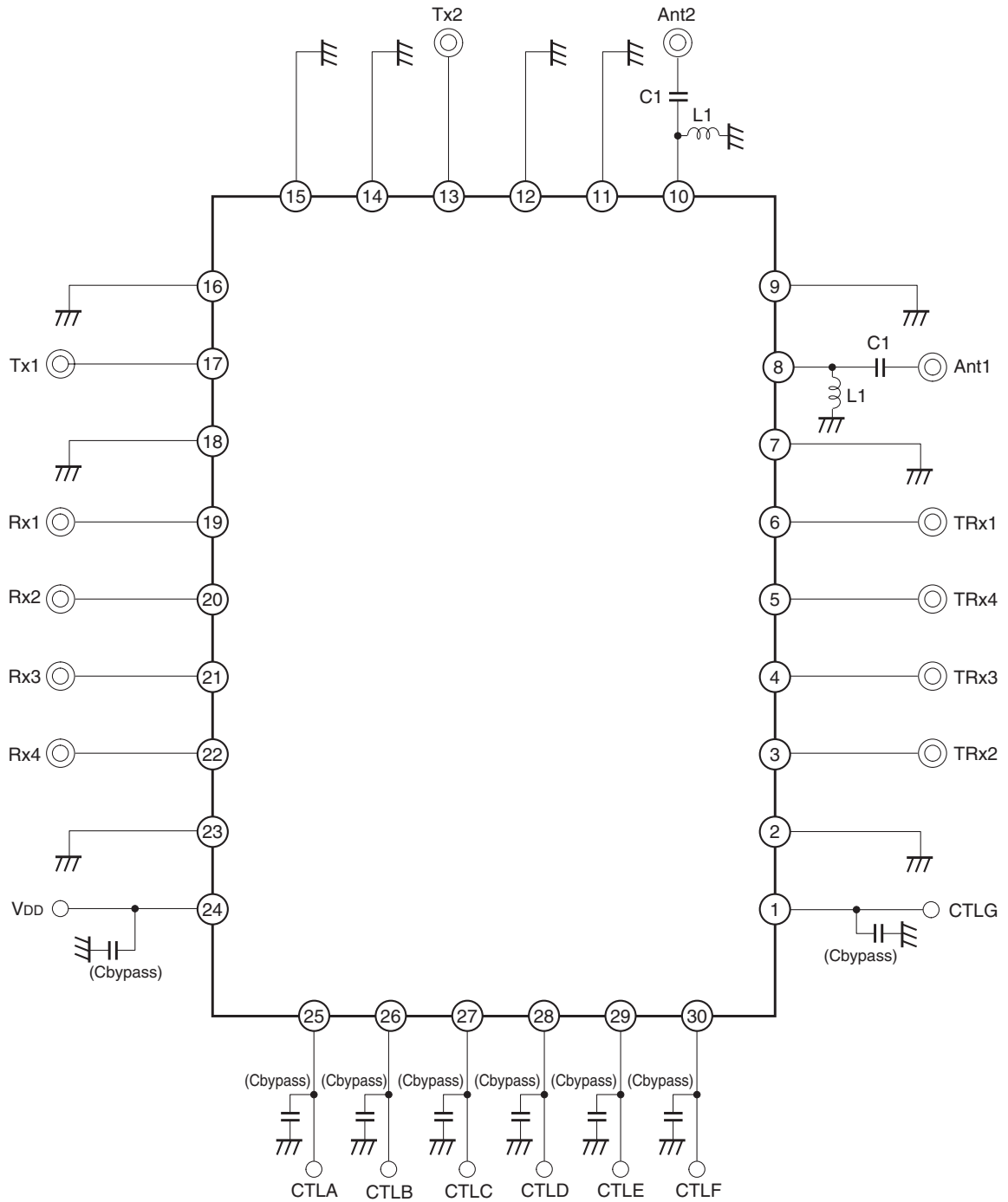

*1 No DC blocking capacitors are required on all RF ports.

*2 DC levels of all RF ports are GND.

*3 C1 (8.2pF) and L1 (22nH) are recommended on Ant ports for IMD2 (Rx-Tx) and ESD protection.

Recommended PCB Layout (Via Position)

(Unit: mm)

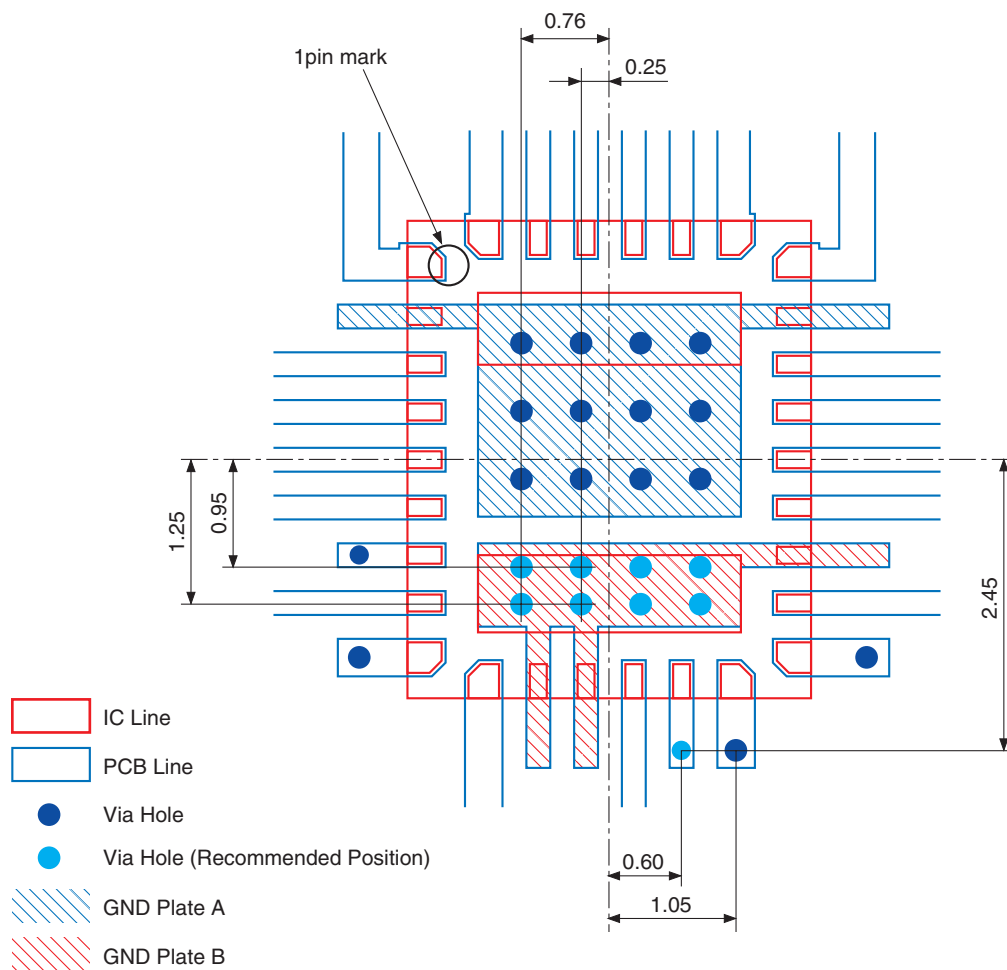

GND Plate A and GND Plate B must be separated each other.
 GND impedances of Plate A and Plate B should be as low as possible.
 GND Terminals of Pin7, 9, 14, 15 must be isolated. And besides not connect to GND Plate A or B.
 (Pin 7 and 9 need not be isolated.)
 GND Terminals of Pin 2 and 23 must be connected to GND Plate A.
 GND Terminals of Pin 11, 12 and 18 must be connected to GND Plate B.
 GND impedances of Pin 14 and 15 are sensitive to GSM Tx attenuation performance.
 It is recommended the GND inductance of Pin 14 is about 0.5nH.
 It is recommended the GND inductance of Pin 15 is about 0.69nH.

Package Outline

(Unit: mm)

30PIN VQFN (PLASTIC)

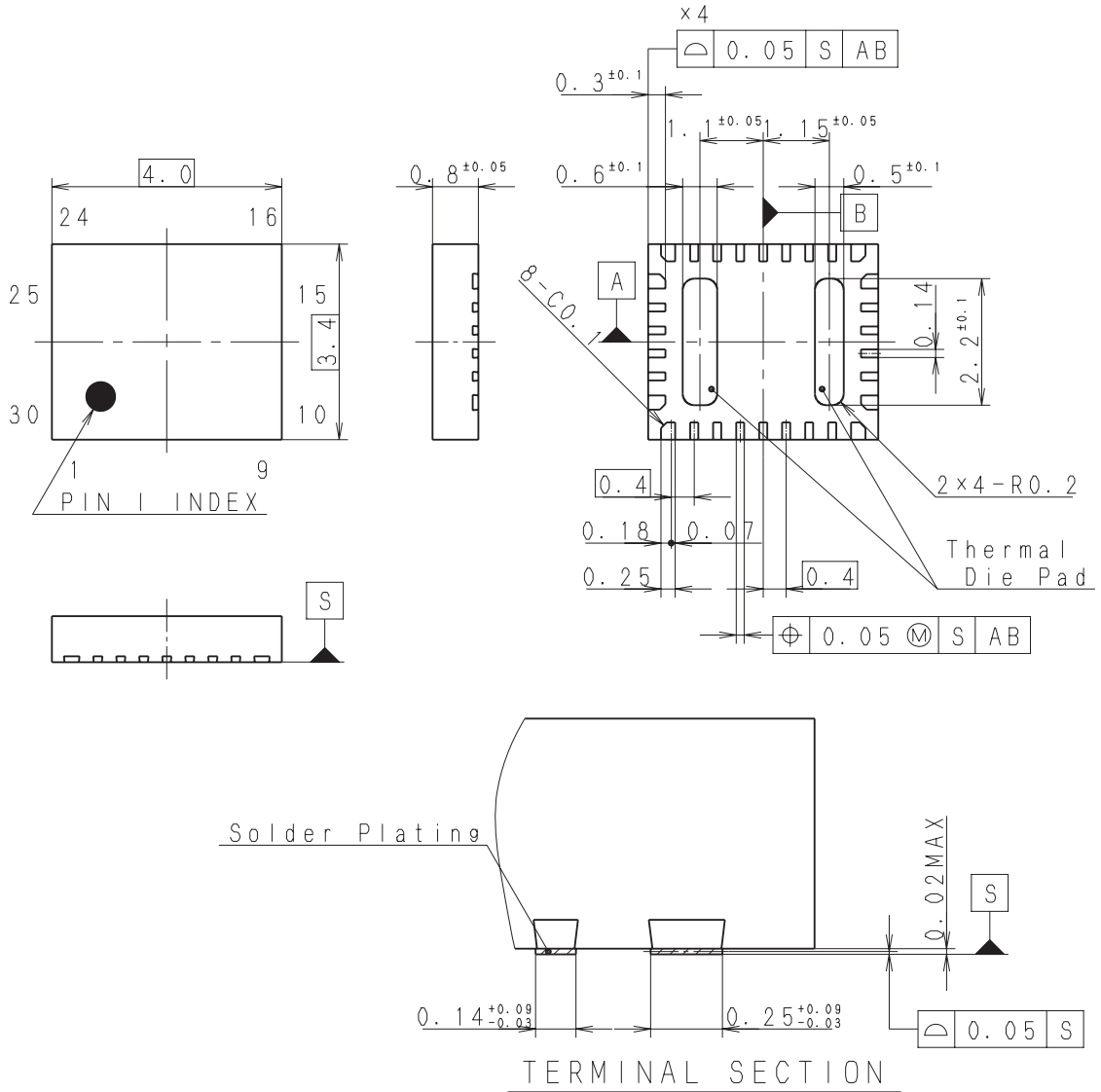

Note:Cutting burr of lead are 0.05mm MAX.

SONY CODE	VQFN-30P-02
JEITA CODE	_____
JEDEC CODE	_____

AP-4000-30014S

Rev. 0

PACKAGE STRUCTURE

PACKAGE MATERIAL	EPOXY RESIN
TERMINAL TREATMENT	SOLDER PLATING
TERMINAL MATERIAL	COPPER ALLOY
PACKAGE MASS	0.04g

LEAD PLATING SPECIFICATIONS

ITEM	SPEC.
LEAD MATERIAL	COPPER ALLOY
SOLDER COMPOSITION	Sn-Bi Bi:1-4wt%
PLATING THICKNESS	5-18µm