Description

The CXM3529XR is SP9T antenna switch for GSM/UMTS dual mode. This IC has a 1.8V CMOS decoder. The Sony GaAs junction gate pHEMT (JPHEMT) MMIC process is used for low insertion loss and high linearity. (Applications: Quad Bands GSM and Triple Bands UMTS)

Features

- ◆ Low Insertion Loss: 0.30dB (Typ.) Tx1 (GSM Low Band Tx)
0.45dB (Typ.) Tx2 (GSM High Band Tx)
0.60dB (Typ.) TRx1 (UMTS Band I)
- ◆ Low Voltage Operation: $V_{DD} = 2.5V$
- ◆ No DC Blocking Capacitors required on RF ports
- ◆ Lead-Free and RoHS Compliant

Package

Small package: 24pin XQFN (2.2mm × 2.9mm × 0.4mm Max.)

Structure

GaAs Junction Gate pHEMT (JPHEMT) MMIC Switch, CMOS Decoder



Absolute Maximum Ratings

(Ta = 25°C)

◆ Bias voltage	V _{DD}	4	V
◆ Control voltage	V _{ctl}	4	V
◆ Input power max. [Tx1]		36	dBm (Duty cycle = 12.5 to 50%)
◆ Input power max. [Tx2]		34	dBm (Duty cycle = 12.5 to 50%)
◆ Input power max. [TRx1, 2, 3]		32	dBm
◆ Input power max. [Rx1, 2, 3, 4]		13	dBm
◆ Operating temperature		-35 to +85	°C
◆ Storage temperature		-65 to +150	°C
◆ Maximum power dissipation*1	PD	500	mW

*1 Copper-clad lamination of glass board (4 layers): 35mm square, t = 0.8mm, FR-4.

Note) Use this product without exceeding the PD value specified in this specification.

If it is used with exceeding the PD value even for a moment, the heat generated by the operation may cause the degradation or breakdown of the product.

Block Diagram

SP9T Antenna Switch

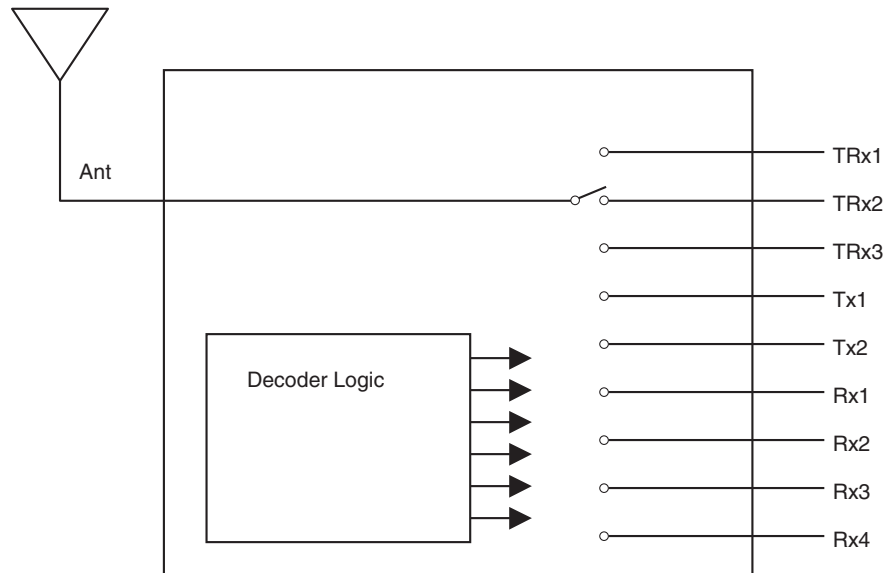

RF Switch

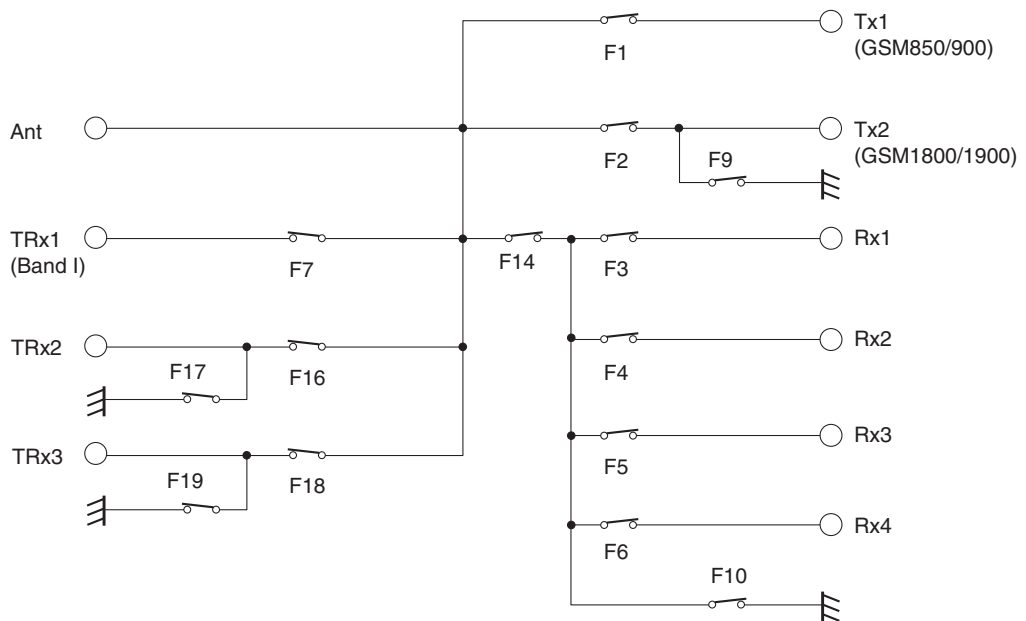

Pin Configuration

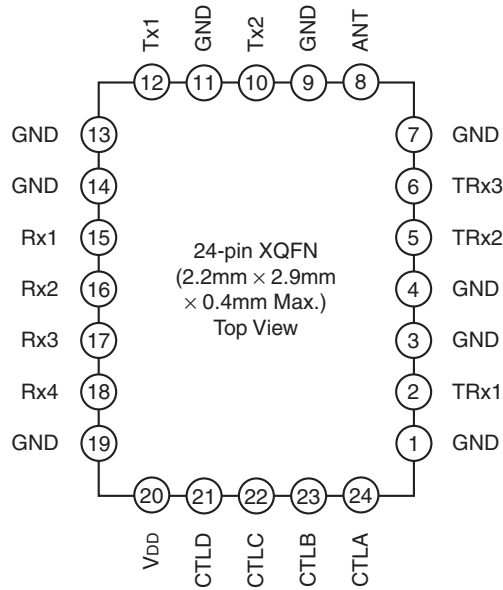

Truth Table

State	Vctl State				Active Path	Switch State													
	A	B	C	D		F1	F2	F3	F4	F5	F6	F7	F9	F10	F14	F16	F17	F18	F19
1	H	H	L	L	Tx1	ON	OFF	OFF	OFF	OFF	OFF	OFF	ON	ON	OFF	OFF	ON	OFF	ON
2	H	L	L	L	Tx2	OFF	ON	OFF	OFF	OFF	OFF	OFF	OFF	ON	OFF	OFF	ON	OFF	ON
3	L	L	L	L	Rx1	OFF	OFF	ON	OFF	OFF	OFF	OFF	ON	OFF	ON	OFF	ON	OFF	ON
4	L	L	H	L	Rx2	OFF	OFF	OFF	ON	OFF	OFF	OFF	ON	OFF	ON	OFF	ON	OFF	ON
5	L	H	H	L	Rx3	OFF	OFF	OFF	OFF	ON	OFF	OFF	ON	OFF	ON	OFF	ON	OFF	ON
6	L	H	L	L	Rx4	OFF	OFF	OFF	OFF	OFF	ON	OFF	ON	OFF	ON	OFF	ON	OFF	ON
7	H	L	H	L	TRx1	OFF	OFF	OFF	OFF	OFF	OFF	ON	ON	ON	OFF	OFF	ON	OFF	ON
8	H	H	H	L	TRx2	OFF	OFF	OFF	OFF	OFF	OFF	OFF	ON	ON	OFF	ON	OFF	OFF	ON
9	*	*	*	H	TRx3	OFF	OFF	OFF	OFF	OFF	OFF	OFF	ON	ON	OFF	OFF	ON	ON	OFF

* : Don't care

DC Bias Condition

(Ta = 25°C)

Item	Min.	Typ.	Max.	Unit
V _{DD}	2.5	2.8	3.3	V
V _{ctl} (H)	1.5	1.8	3.3	V
V _{ctl} (L)	0	—	0.3	V

Electrical Characteristics

Specification 1

(Ta = 25°C, VDD = 2.5V, Vctl = 1.5/0V)

Item	Symbol	Port	Condition	Min.	Typ.	Max.	Unit
Insertion loss	IL	Ant-Tx1	*1	—	0.30	0.45	dB
			*2	—	0.45	0.60	
		Ant-Rx1	*3	—	0.75	0.90	
			*4	—	1.00	1.15	
		Ant-Rx2	*3	—	0.75	0.90	
			*4	—	1.00	1.15	
		Ant-Rx3	*3	—	0.75	0.90	
			*4	—	1.00	1.15	
		Ant-Rx4	*3	—	0.75	0.90	
			*4	—	1.00	1.15	
		Ant-TRx1	*5	—	0.55	0.70	
			*6	—	0.60	0.75	
		Ant-TRx2	*7	—	0.45	0.60	
			*8	—	0.45	0.60	
			*9	—	0.57	0.72	
			*10	—	0.60	0.75	
Ant-TRx3	*7	—	0.45	0.60			
	*8	—	0.45	0.60			
	*9	—	0.60	0.75			
	*10	—	0.62	0.77			
VSWR	VSWR	All ports in Active Paths	824 to 2170MHz	—	1.20	1.50	—
Harmonics*	2fo	Tx1-Ant	*1	—	-52	-36	dBm
				3fo	—	-40	
	2fo	Tx2-Ant	*2	—	-52	-36	
				3fo	—	-38	
	2fo	TRx1-Ant	*5	—	-53	-39	
				3fo	—	-54	
	2fo	TRx2-Ant	*7,*9	—	-56	-39	
				3fo	—	-55	
2fo	TRx3-Ant	*7,*9	—	-56	-39		
			3fo	—	-53	-39	
Inter modulation product power in Rx band	IMD2	TRx1-Ant	*11, *19	—	-106	-97	dBm
			*12, *19	—	-108	-97	
		TRx2-Ant	*13, *19	—	-106	-97	
			*14, *19	—	-117	-97	
		TRx3-Ant	*12, *19	—	-106	-97	
			*13, *19	—	-105	-97	
	IMD3	TRx1-Ant	*14, *19	—	-116	-97	
			*15, *19	—	-105	-97	
		TRx2-Ant	*16, *19	—	-105	-97	
			*17, *19	—	-108	-97	
TRx3-Ant	*18, *19	—	-109	-97			
	*16, *19	—	-104	-97			
			*17, *19	—	-107	-97	
			*18, *19	—	-108	-97	

Item	Symbol	Port	Condition	Min.	Typ.	Max.	Unit
Switching time	Ts		50%Ctl to 90%RF	—	3	5	μS
Control current	Ictl		Vctl = 1.80V	—	1	5	μA
Supply current	Idd		VDD = 2.80V	—	0.20	0.40	mA

Electrical Characteristics are measured with all RF ports terminated in 50Ω.

- *1 Tx1 input power: 34dBm, 824 to 915MHz, Tx1 enabled
- *2 Tx2 input power: 32dBm, 1710 to 1910MHz, Tx2 enabled
- *3 Ant input power: 10dBm, 869 to 960MHz, Rx1, Rx2, Rx3 or Rx4 enabled
- *4 Ant input power: 10dBm, 1805 to 1990MHz, Rx1, Rx2, Rx3 or Rx4 enabled
- *5 TRx1 input power: 26dBm, 1920 to 1980MHz, TRx1 enabled
- *6 Ant input power: 10dBm, 2110 to 2170MHz, TRx1 enabled
- *7 TRx2 or TRx3 input power: 26dBm, 824 to 849MHz, TRx2 or TRx3 enabled
- *8 Ant input power: 10dBm, 869 to 894MHz, TRx2 or TRx3 enabled
- *9 TRx2 or TRx3 input power: 26dBm, 1710 to 1910MHz, TRx2 or TRx3 enabled
- *10 Ant input power: 10dBm, 1805 to 1990MHz, TRx2 or TRx3 enabled
- *11 TRx1 input power: 20dBm, 1950MHz, Ant input power: -15dBm, 190MHz, TRx1 enabled
- *12 TRx2 or TRx3 input power: 20dBm, 1745MHz, Ant input power: -15dBm, 95MHz, TRx2 or TRx3 enabled
- *13 TRx2 or TRx3 input power: 20dBm, 1880MHz, Ant input power: -15dBm, 80MHz, TRx2 or TRx3 enabled
- *14 TRx2 or TRx3 input power: 20dBm, 835MHz, Ant input power: -15dBm, 45MHz, TRx2 or TRx3 enabled
- *15 TRx1 input power: 20dBm, 1950MHz, Ant input power: -15dBm, 1760MHz, TRx1 enabled
- *16 TRx2 or TRx3 input power: 20dBm, 1745MHz, Ant input power: -15dBm, 1650MHz, TRx2 or TRx3 enabled
- *17 TRx2 or TRx3 input power: 20dBm, 1880MHz, Ant input power: -15dBm, 1800MHz, TRx2 or TRx3 enabled
- *18 TRx2 or TRx3 input power: 20dBm, 835MHz, Ant input power: -15dBm, 790MHz, TRx2 or TRx3 enabled
- *19 Measured with the recommended circuit

Specification 1-Isolation

(Ta = 25°C, VDD = 2.5V, Vctl = 1.5/0V)

Item	Symbol	Path		Condition	Min.	Typ.	Max.	Unit
		Active	Isolation					
Isolation	ISO	Tx1	Tx1-Rx1	824 to 915MHz	35	46	—	dB
			Tx1-Rx2		35	55	—	
			Tx1-Rx3		35	59	—	
			Tx1-Rx4		35	57	—	
			Tx1-TRx1		25	29	—	
			Tx1-TRx2		25	48	—	
			Tx1-TRx3		25	38	—	
			Tx1-Tx2		25	28	—	
			Tx1-Tx2		1648 to 1830MHz	18	22	
		Tx2	Tx2-Rx1	1710 to 1910MHz	35	51	—	
			Tx2-Rx2		35	55	—	
			Tx2-Rx3		35	58	—	
			Tx2-Rx4		35	55	—	
			Tx2-TRx1		20	23	—	
			Tx2-TRx2		20	38	—	
			Tx2-TRx3		20	31	—	
			Tx2-Tx1		16	19	—	
		TRx1	TRx1-Rx1	1920 to 1980MHz	30	52	—	
			TRx1-Rx2		30	57	—	
			TRx1-Rx3		30	57	—	
			TRx1-Rx4		30	54	—	
			TRx1-TRx2		27	34	—	
			TRx1-TRx3		23	26	—	
			TRx1-Tx1		17	19.5	—	
			TRx1-Tx2		20	28	—	
		TRx2	TRx2-Rx1	824 to 849MHz	30	59	—	
			TRx2-Rx2		30	60	—	
			TRx2-Rx3		30	62	—	
			TRx2-Rx4		30	60	—	
			TRx2-TRx1		20	28	—	
			TRx2-TRx3		20	28	—	
			TRx2-Tx1		20	26	—	
			TRx2-Tx2		20	43	—	
			TRx2-Rx1		1710 to 1910MHz	30	52	
			TRx2-Rx2	30		57	—	
			TRx2-Rx3	30		59	—	
			TRx2-Rx4	30		56	—	
			TRx2-TRx1	18		21	—	
			TRx2-TRx3	18		20.5	—	
			TRx2-Tx1	17		19.5	—	
			TRx2-Tx2	20		33	—	

Item	Symbol	Path		Condition	Min.	Typ.	Max.	Unit
		Active	Isolation					
Isolation	ISO	TRx3	TRx3-Rx1	824 to 849MHz	30	59	—	dB
			TRx3-Rx2		30	60	—	
			TRx3-Rx3		30	62	—	
			TRx3-Rx4		30	59	—	
			TRx3-TRx1		20	29	—	
			TRx3-TRx2		20	30	—	
			TRx3-Tx1		20	26	—	
			TRx3-Tx2		20	43	—	
			TRx3-Rx1		30	52	—	
			TRx3-Rx2	30	57	—		
			TRx3-Rx3	30	59	—		
			TRx3-Rx4	30	55	—		
			TRx3-TRx1	18	22	—		
			TRx3-TRx2	18	22	—		
			TRx3-Tx1	17	19.5	—		
			TRx3-Tx2	20	36	—		

Electrical Characteristics are measured with all RF ports terminated in 50Ω.

Recommended Circuit

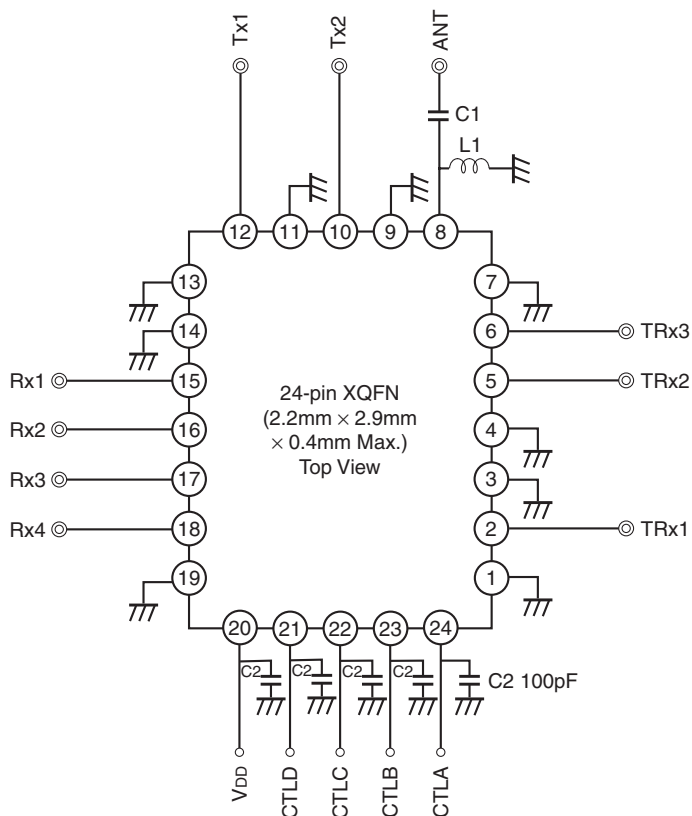

- *1: When the DC level of the connected device is GND or open, no DC block capacitors are required on the RF port.
- *2: DC levels of all RF ports are GND.
- *3: L1 (22nH) and C1 (22pF) are recommended on Ant port for ESD protection.

Package Outline

(Unit: mm)

24PIN XQFN (PLASTIC)

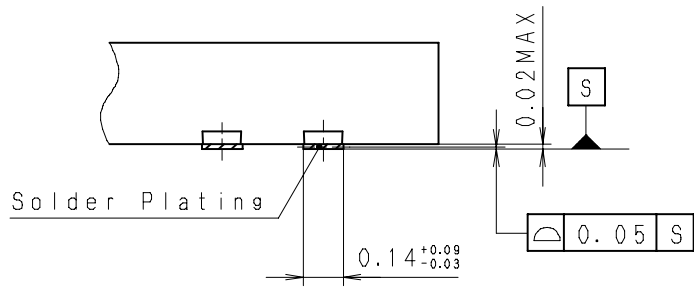
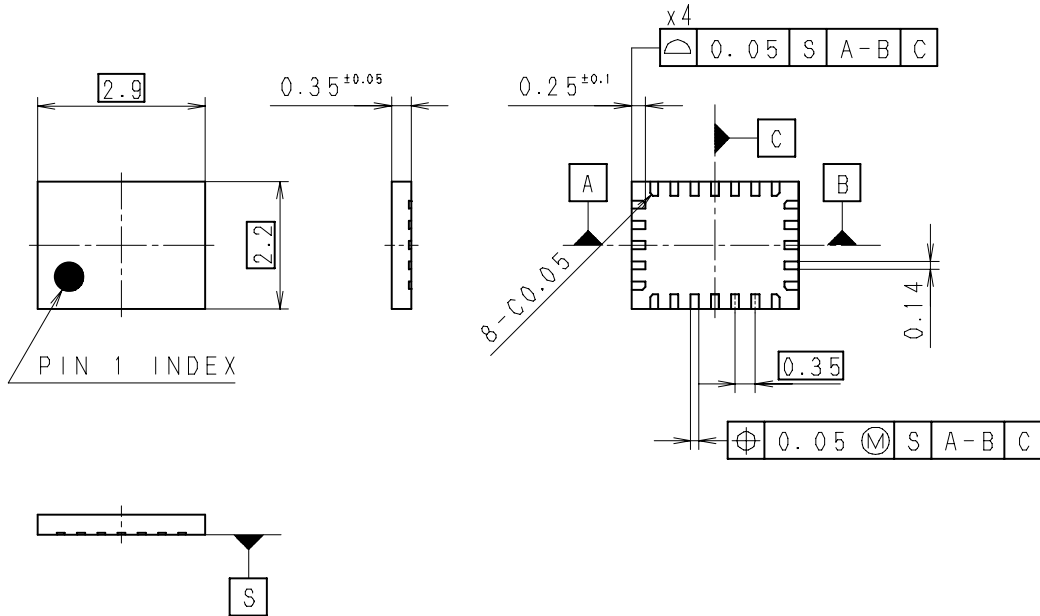

TERMINAL SECTION

Note:Cutting burr of lead are 0.05mm MAX.

SONY CODE	XQFN-24P-02
JEITA CODE	_____
JEDEC CODE	_____

AP-4000-24046S Rev. 0

PACKAGE STRUCTURE

PACKAGE MATERIAL	EPOXY RESIN
TERMINAL TREATMENT	SOLDER PLATING
TERMINAL MATERIAL	COPPER ALLOY
PACKAGE MASS	0.01g

LEAD PLATING SPECIFICATIONS

ITEM	SPEC.
LEAD MATERIAL	COPPER ALLOY
SOLDER COMPOSITION	Sn-Bi Bi:1-4wt%
PLATING THICKNESS	5-18µm