

1:4 Clock Fanout Buffer

Features

- Low-voltage operation
- $V_{DD} = 3.3V$
- 1:4 Fanout
- Single-input configurable for
 - LVDS, LVPECL, or LVTTTL
 - Four differential pairs of LVDS outputs
- Drives 50- or 100-ohm load (selectable)
- Low input capacitance
- Low output skew
- Does not exceed Bellcore 802.3 standards
- Operation at \Rightarrow 350 MHz – 700 Mbps
- Low propagation delay *Typical* ($t_{pd} < 4\text{ ns}$)
- Industrial versions available
- Packages available include TSSOP/SOIC

Description

The Cypress CY2 series of network circuits is produced using advanced 0.35-micron CMOS technology, achieving the industry's fastest logic.

The Cypress CY2DL814 fanout buffer features a single LVDS-, LVPECL-, or LVTTTL-compatible input and four LVDS output pairs.

Designed for data-communication clock management applications, the fanout from a single input reduces loading on the input clock.

The CY2DL814 is ideal for both level translations from single ended to LVDS and/or for the distribution of LVDS-based clock signals. The Cypress CY2DL814 has configurable input and output functions. The input can be selectable for LVPECL/LVTTTL or LVDS signals while the output driver's support standard and high drive LVDS. Drive either a 50-ohm or 100-ohm line with a single part number/device.

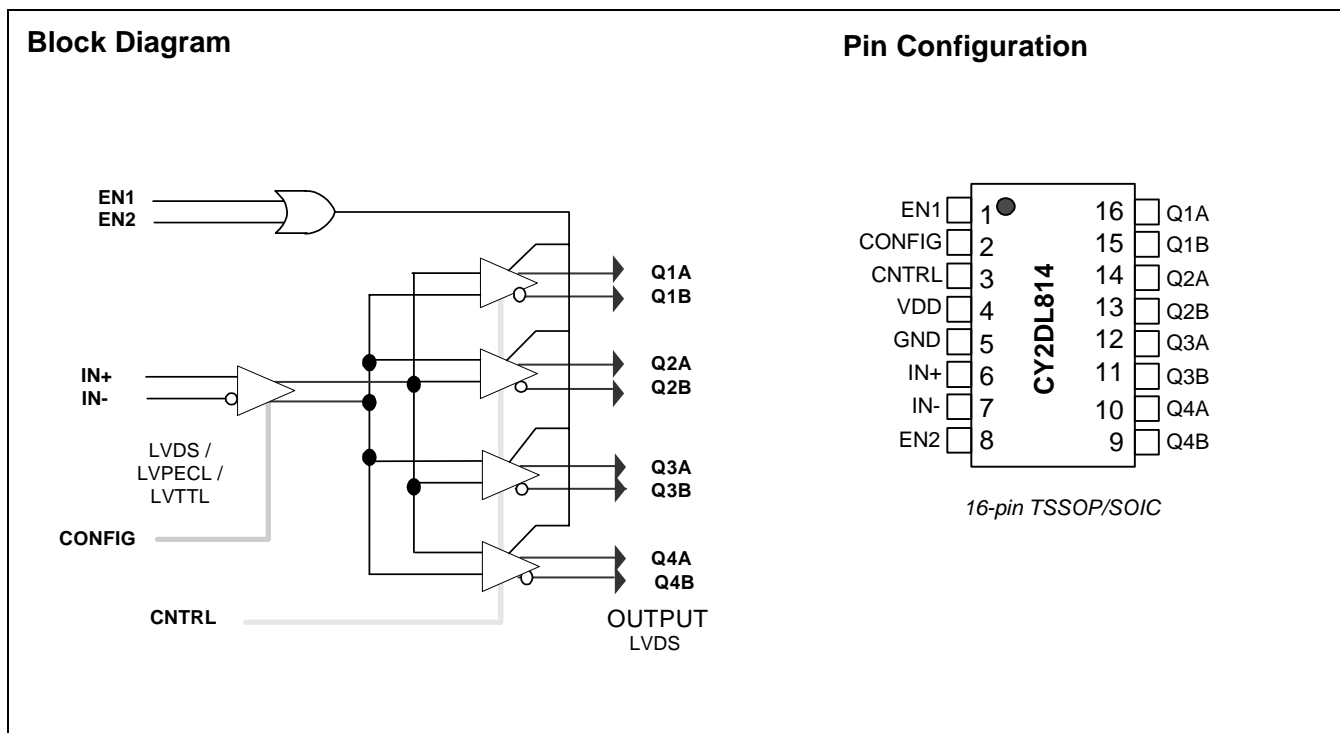



Pin Description

Pin Number	Pin Name	Pin Standard Interface	Description
6,7	IN+, IN-	Configurable	Differential input pair or single line. LVPECL default. See config below.
3	CNTRL	LVTTL/LVCMOS	Converts into a High drive driver from a standard LVDS. Standard drive (logic = 0) B/High drive/Bus (logic = 1)
2	CONFIG	LVTTL/LVCMOS	Converts inputs (IN ⁺ /IN ⁻), (EN, EN#) from the default LVPECL/LVDS (logic = 0) To LVTTL/LVCMOS (logic = 1)
1,8	EN1, EN2	LVTTL/LVCMOS	Enable/disable logic. See <i>Table 1</i> below for details.
16,15,14,13 12,11,10,9	Q1A, Q1B, Q2A, Q2B, Q3A, Q3B, Q4A, Q4B	LDVS	Differential outputs.
4	V _{DD}	POWER	Positive supply voltage
5	G _{ND}	POWER	Ground

Maximum Ratings^{[1][2]}

Storage Temperature:	-65°C to + 150°C	(Outputs only)	-0.3V to V _{DD} + 0.3V
Ambient Temperature:.....	-40°C to +85°C	DC Input Voltage	-0.3V to V _{DD} + 0.3V
Supply Voltage to Ground Potential		DC Output Voltage.....	-0.3V to V _{DD} + 0.9V
(Inputs and V _{CC} only).....	-0.3V to 4.6V	Power Dissipation.....	0.75W
Supply Voltage to Ground Potential			

Table 1. EN1 EN2 Function Table–Differential Input Mode

Enable Logic		Input		Outputs	
EN1	EN2	IN+	IN-	QnA	QnB
H	X	H	L	H	L
H	X	L	H	L	H
X	L	H	L	H	L
X	L	L	H	L	H
L	H	X	X	Z	Z

Table 2. Output Drive Control for Standard and Bus/B/High Drive B

CNTRL Pin 3 Binary Value	Drive STD	Impedance	Output Voltage Value
0	Standard	100 ohm	V _O = V _{output}
		50 ohm	V = 1/2 * V _O
1	High Drive/Bus/B	100 ohm	V = 2 * V _O
		50 ohm	V = V _O

Note:

- Stresses greater than those listed under absolute maximum ratings may cause permanent damage to the device. This is intended to be a stress rating only and functional operation of the device at these or any other conditions above those indicated in the operation sections of this specification is not implied. Exposure to absolute maximum rating conditions for extended periods may affect reliability.
- Multiple Supplies: The voltage on any input or I/O pin cannot exceed the power pin during power-up. Power supply sequencing is NOT required.

Table 3. Input Receiver Configuration for Differential or LVTTTL/LVCMOS

CONFIG Pin 2 Binary Value	Input Receiver Family	Input Receiver Type
1	LVTTTL in LVCMOS	Single-ended, Non-inverting, Inverting, Void of Bias Resistors
0	LVDS	Low-voltage Differential Signaling
	LVPECL	Low-voltage Pseudo (Positive) Emitter Coupled Logic

Table 4. Function Control of the TTL Input Logic Used to Accept or Invert the Input Signal

LVTTTL/LVCMOS Input Logic			
Input Condition		Input Logic	Output Logic Q Pins, Q1A or Q1
Ground	IN- Pin 7		
	IN+ Pin 6	Input	True
V _{CC}	IN- Pin 7		
	IN+ Pin 6	Input	Invert
Ground	IN+ Pin 6		
	IN- Pin 7	Input	True
V _{CC}	IN+ Pin 6		
	IN- Pin 7	Input	Invert

Table 5. Power Supply Characteristics

Parameter	Description	Test Conditions	Min.	Typ.	Max.	Unit
I _{CCD}	Dynamic Power Supply Current	V _{DD} = Max. Input toggling 50% Duty Cycle, Outputs Open		1.5	2.0	mA/MHz
I _C	Total Power Supply Current	V _{DD} = Max. Input toggling 50% Duty Cycle, Outputs Open f _L =100 MHz		90	100	mA

Table 6. D.C Electrical Characteristics: 3.3V–LVDS Input

Parameter	Description	Conditions		Min.	Typ.	Max.	Unit
V _{ID}	Magnitude of Differential Input Voltage			100		600	mV
V _{IC}	Common-mode of Differential Input Voltage V _{ID} (min. and max.)			V _{ID} /2	2.4–(V _{ID} /2)		V
V _{IH}	Input High Voltage	Guaranteed Logic High Level	Config/Cntrl Pins	2			V
V _{IL}	Input Low Voltage	Guaranteed Logic Low Level				0.8	V
I _{IH}	Input High Current	V _{DD} = Max.	V _{IN} = V _{DD}		±10	±20	μA
I _{IL}	Input Low Current	V _{DD} = Max.	V _{IN} = V _{SS}		±10	±20	μA
I _I	Input High Current	V _{DD} = Max., V _{IN} = V _{DD} (max.)				±20	μA

Table 7. D.C Electrical Characteristics: 3.3V–LVPECL Input

Parameter	Description	Conditions		Min.	Typ.	Max.	Unit
V _{ID}	Differential Input Voltage p-p	Guaranteed Logic High Level		400		2600	mV
V _{CM}	Common-mode Voltage			1.65		2.25	V
I _{IH}	Input High Current	V _{DD} = Max.	V _{IN} = V _{DD}		±10	±20	μA
I _{IL}	Input Low Current	V _{DD} = Max.	V _{IN} = V _{SS}		±10	±20	μA
I _I	Input High Current	V _{DD} = Max., V _{IN} = V _{DD} (Max.)				±20	μA

Table 8. D.C Electrical Characteristics: 3.3V–LVTTTL/LVCMOS Input

Parameter	Description	Conditions		Min.	Typ.	Max.	Unit
V _{IH}	Input High Voltage	Guaranteed Logic High Level		2			V
V _{IL}	Input Low Voltage	Guaranteed Logic Low Level				0.8	V
I _{IH}	Input High Current	V _{DD} = Max.	V _{IN} = 2.7V			1	μA
I _{IL}	Input Low Current	V _{DD} = Max.	V _{IN} = 0.5V			-1	μA
I _I	Input High Current	V _{DD} = Max., V _{IN} = V _{DD} (Max.)				20	μA
V _{IK}	Clamp Diode Voltage	V _{DD} = Min., I _{IN} = -18 mA			-0.7	-1.2	V
V _H	Input Hysteresis				80		mV

Table 9. D.C Electrical Characteristics: 3.3V–LVDS OUTPUT

Parameter	Description	Conditions		Min.	Typ.	Max.	Unit
I _{VOD}	Differential output voltage p-p	V _{DD} = 3.3V, V _{IN} = V _{IH} , or V _{IL}	RL = 100 ohm	0.25		0.45	V
VOC(SS)	Steady-state common-mode output voltage					226	mV
Delta VOC(SS)	Change in VOC(SS) between logic states			-50	3	50	mV
VOC(PP)	Peak to peak common mode output voltage					150	mV
I _{OS}	Output short circuit	QA = 0V or QB = 0V				-20	mA
V _{oh}	Output voltage high					1475	mV
V _{ol}	Output voltage low			925			mV

Table 10. AC Parameters

Parameter	Description	Conditions		Min.	Typ.	Max.	Unit
Rise Time	Pin control (pin 3) logic is "FALSE" defaulting to 100 ohm output drivers. Differential 20% to 80%	CL=10 pF RL and CL to GND 3 CL = C _{intrinsic} and C _{external}	RL = 100 ohm			1.4	ns
Fall Time						1.4	ns
Rise Time	Pin control (pin 3) logic is "True" defaulting to 50 ohm output drivers. Differential 20% to 80%	CL=10 pF RL and CL to GND 3 CL = C _{intrinsic} and C _{external}	RL = 50 ohm Output boost		350	600	ps
Fall Time					350	600	ps

Table 11. AC Switching Characteristics @ 3.3 V (V_{DD} = 3.3V ±5%, Temperature = -40°C to +85°C)

Parameter	Description	Conditions	Min.	Typ.	Max.	Unit
IN [+,-] to Q[A,B] Data and Clock Speed						
t _{PLH}	Propagation Delay – Low to High	V _{OD} = 100 mV	3	4	5	ns
t _{PHL}	Propagation Delay – High to Low		3	4	5	ns
T _{pd}	Propagation Delay		3	4	5	ns
IN [1,2] to Q[A,B] Control Speed						
T _{Pe}	Enable (EN) to functional operation				6	ns
T _{pd}	Functional operation to Disable				5	ns
Q[A,B] Output Skews						
t _{SK(0)}	Output Skew: Skew between outputs of the same package (in phase)				0.2	ns
t _{SK(p)}	Pulse Skew: Skew between opposite transitions of the same output (t _{PHL} -t _{PLH})			0.2		ns
t _{SK(t)}	Package Skew: Skew between outputs of different packages at the same power supply voltage, temperature and package type. Same input signal level and output load.	V _{ID} = 100 mV			1	ns

Table 12. High Frequency Parametrics

Parameter	Description	Conditions	Min.	Typ.	Max.	Unit
Fmax	Maximum frequency $V_{DD} = 3.3V$	50% duty cycle $tW(50-50)$ Standard Load Circuit.			400	MHz
Fmax(20)	Maximum frequency $V_{DD} = 3.3V$	20% duty cycle $tW(50-50)$ LVPECL Input $V_{IN} = V_{IH}(\text{Max.})/V_{IL}(\text{Min.})$ $V_{OUT} = V_{OH}(\text{Min.})/V_{OL}(\text{Max.})$ (Limit)			200	MHz
TW	Minimum pulse $V_{DD} = 3.3V$	LVPECL Input $V_{IN} = V_{IH}(\text{Max.})/V_{IL}(\text{Min.})$ $F = 100\text{ MHz}$ $V_{OUT} = V_{OH}(\text{Min.})/V_{OL}(\text{Max.})$ (Limit)	1			ns

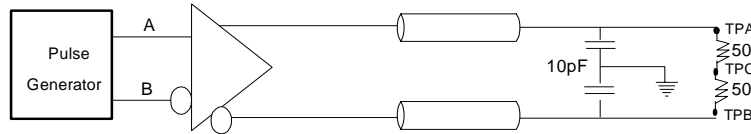
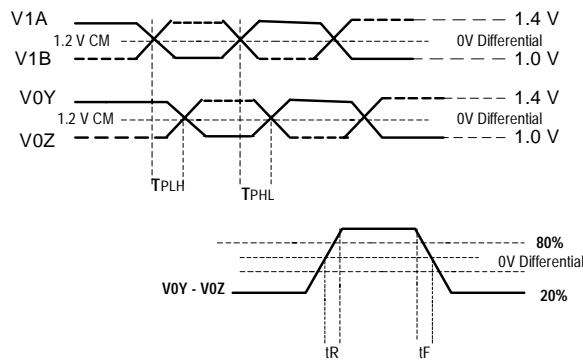
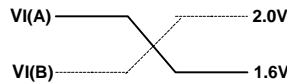
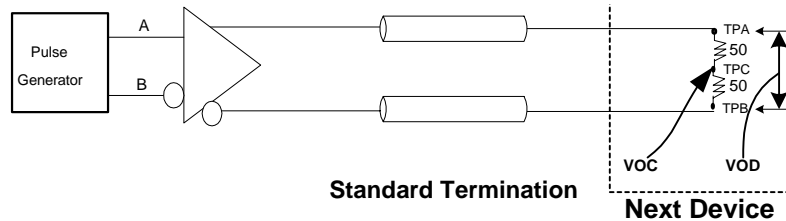
Standard Termination

Figure 1. Differential Receiver to Driver Propagation Delay and Driver Transition Time^[3,4,5,6]

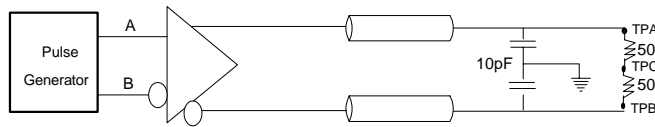
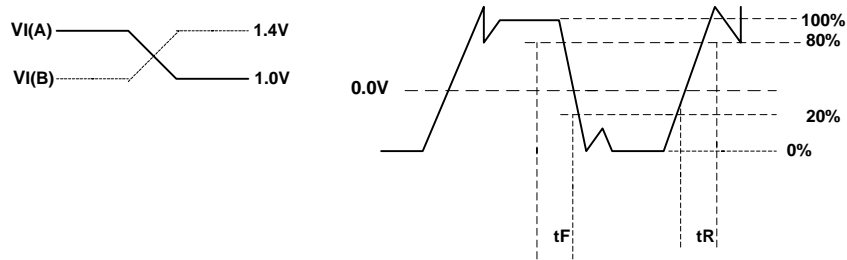
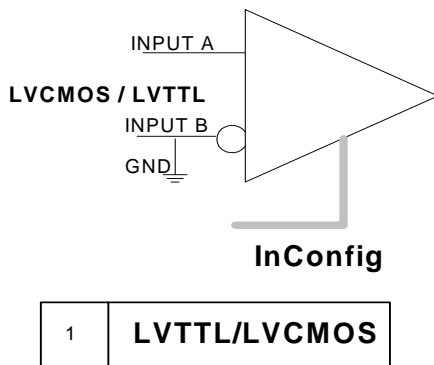
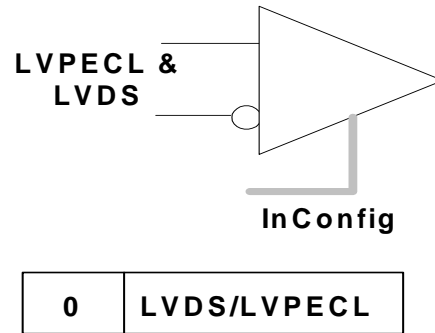
Figure 2. Test Circuit and Voltage Definitions for the Driver Common-mode Output Voltage^[3,4,5,6]
Notes:

- All input pulses are supplied by a frequency generator with the following characteristics: t_R and $t_F \leq 1\text{ ns}$; pulse rerate = 50 Mpps; pulse width = $10 \pm 0.2\text{ ns}$.
- $R_L = 50\text{ ohm} \pm 1\%$ $Z_{line} = 50\text{ ohm } 6''$.
- CL includes instrumentation and fixture capacitance within 6 mm of the UT.
- TPA and B are used for prop delay and Rise/Fall measurements. TPC is used for VOC measurements only and is otherwise connected to V_{DD-2} .

Standard Termination

Figure 3. Test Circuit and Voltage Definitions for the Differential Output Signal^[3,4,5,6]

Figure 4. LVC MOS/LVTTL Single-ended Input Value^[7]

Figure 5. LVPECL or LVDS Differential Input Value^[8]
Ordering Information

Part Number	Package Type	Product Flow
CY2DL814ZI	16-pin TSSOP	Industrial, -40°C to 85°C
CY2DL814ZIT	16-pin TSSOP–Tape and Reel	Industrial, -40°C to 85°C
CY2DL814SI	16-pin SOIC	Industrial, -40°C to 85°C
CY2DL814SIT	16-pin SOIC–Tape and Reel	Industrial, -40°C to 85°C
CY2DL814ZC	16-pin TSSOP	Commercial, 0°C to 70 °C
CY2DL814ZCT	16-pin TSSOP–Tape and Reel	Commercial, 0°C to 70 °C
CY2DL814SC	16-pin SOIC	Commercial, 0°C to 70 °C
CY2DL814SCT	16-pin SOIC–Tape and Reel	Commercial, 0°C to 70 °C

Notes:

7. LVC MOS/LVTTL single ended input value. Ground either input: when on the B side then non-inversion takes place. If A side is grounded, the signal becomes the complement of the input on B side. See *Table 4*.
8. LVPECL or LVDS differential input value.

Package Drawing and Dimensions

16-lead (150-mil) Molded SOIC S16

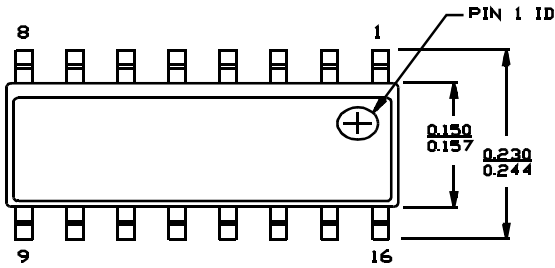

DIMENSIONS IN INCHES
MIN.
MAX.

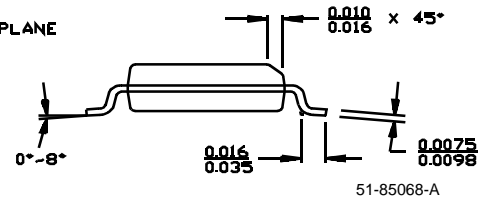
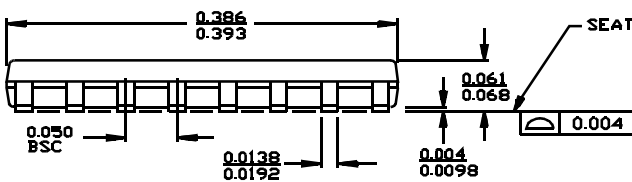

51-85068-A

16-lead Thin Shrunken Small Outline Package (4.40 MM Body) Z16

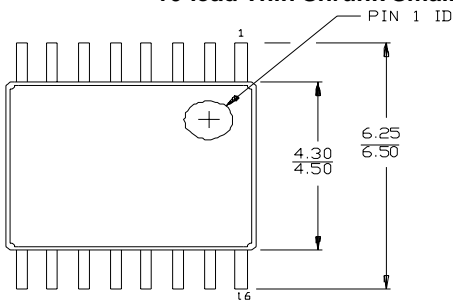

DIMENSIONS IN MILLIMETERS.

MIN.
MAX.

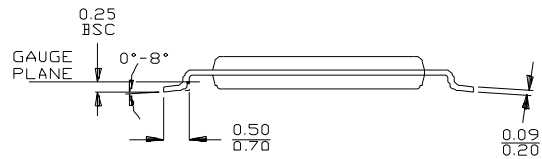
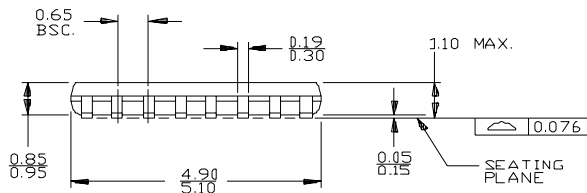

51-85091

ComLink is a trademark of Cypress Semiconductor Corporation. All product and company names mentioned in this document are the trademarks of their respective holders.



Document Title: ComLink™ Series CY2DL814 1:4 Clock Fanout Buffer
Document Number: 38-07057

REV.	ECN NO.	Issue Date	Orig. of Change	Description of Change
**	115362	07/10/02	EHX	New Data Sheet
*A	122744	12/14/02	RBI	Added power up requirements to maximum ratings information.