

DAC2814

DUAL 12-BIT DIGITAL-TO-ANALOG CONVERTER (Serial Interface)

FEATURES

- COMPLETE DUAL DAC — INCLUDES INTERNAL REFERENCES AND OUTPUT AMPLIFIERS
- GUARANTEED SPECIFICATIONS OVER TEMPERATURE
- GUARANTEED MONOTONIC OVER TEMPERATURE
- HIGH-SPEED SERIAL INTERFACE (10MHz CLOCK)
- LOW POWER: 300mW (150mW/DAC)
- LOW GAIN DRIFT: 5ppm/°C
- LOW NONLINEARITY: $\pm 1/2$ LSB max
- UNIPOLAR OR BIPOLAR OUTPUT
- CLEAR/RESET TO UNIPOLAR OR BIPOLAR ZERO

DESCRIPTION

The DAC2814 is one in a family of dual and quad 12-bit digital-to-analog converters. Serial, 8-bit, 12-bit interfaces are available.

The DAC2814 is complete. It contains CMOS logic, switches, a high-performance buried-zener reference, and low-noise bipolar output amplifiers. No external components are required for either unipolar 0 to 10V, 0 to -10V, or bipolar $\pm 10V$ output ranges.

The DAC2814 has a high-speed serial interface capable of being clocked at 10MHz. Serial data are clocked DAC B MSB first into a 24-bit shift register, then strobed into each DAC separately or simultaneously as required. The DAC has an asynchronous clear control for reset to unipolar or bipolar zero depending on the mode selected. This feature is useful for power-on reset or system calibration. The DAC2814 is packaged in a 24-pin plastic DIP rated for the -40°C to +85°C extended industrial temperature range.

High-stability laser-trimmed thin film resistors assure high reliability and true 12-bit integral and differential linearity over the full specified temperature range.

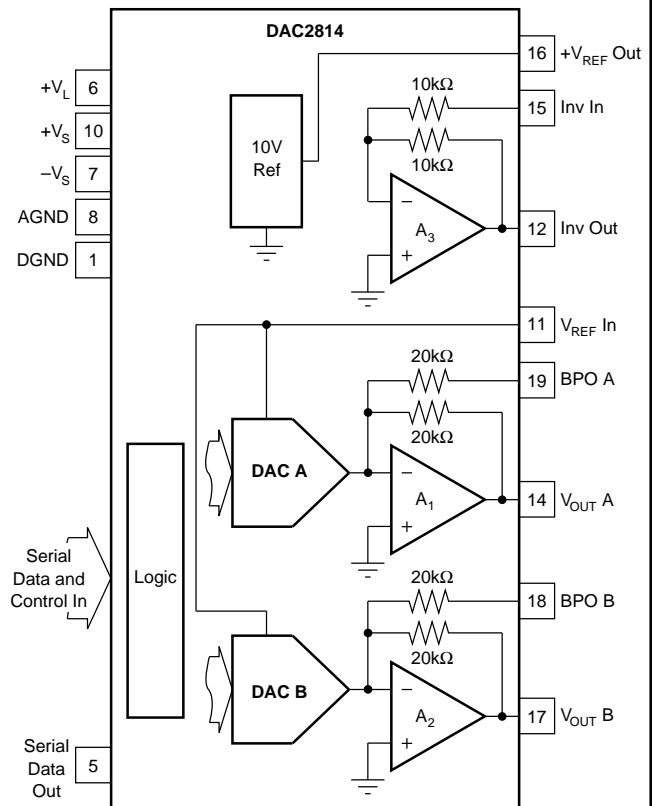

International Airport Industrial Park • Mailing Address: PO Box 11400 • Tucson, AZ 85734 • Street Address: 6730 S. Tucson Blvd. • Tucson, AZ 85706
 Tel: (520) 746-1111 • Twx: 910-952-1111 • Cable: BBRCORP • Telex: 066-6491 • FAX: (520) 889-1510 • Immediate Product Info: (800) 548-6132

SPECIFICATIONS, Guaranteed over $T_A = -40^{\circ}\text{C}$ to $+85^{\circ}\text{C}$ unless otherwise specified.

ELECTRICAL

Specifications as shown for $V_S = \pm 12\text{V}$ or $\pm 15\text{V}$, $V_L = +5\text{V}$, and $R_L = 2\text{k}\Omega$ unless otherwise noted.

PARAMETER	CONDITIONS	DAC2814AP			DAC2814BP			UNITS
		MIN	TYP	MAX	MIN	TYP	MAX	
DIGITAL INPUTS Resolution V_{IH} (Input High Voltage) V_{IL} (Input Low Voltage) I_{IN} (Input Current) C_{IN} (Input Capacitance)	$T_A = 25^{\circ}\text{C}$ $T_A = -40^{\circ}\text{C}$ to $+85^{\circ}\text{C}$	12 +2 0		+5 +0.8 ± 1 ± 10	*		*	Bits V V μA μA pF
DIGITAL OUTPUT Data Out V_{OL} V_{OH}	$I_{SINK} = 1.6\text{mA}$ $I_{SOURCE} = 500\mu\text{A}$	0 +2.4		+0.4 +5	*		*	V V
ACCURACY Integral, Relative Linearity ⁽¹⁾ Differential Nonlinearity ⁽²⁾ Unipolar Offset Error Bipolar Zero Error Gain Error Unipolar, Bipolar Power Supply Sensitivity ⁽³⁾	$T_A = 25^{\circ}\text{C}$ $T_A = -40^{\circ}\text{C}$ to $+85^{\circ}\text{C}$ $T_A = +25^{\circ}\text{C}$ $T_A = -40^{\circ}\text{C}$ TO $+85^{\circ}\text{C}$ With Internal or External 10.0V Ref $V_S = \pm 11.4\text{V}$ to $\pm 18\text{V}$ $V_L = +4.5\text{V}$ to $+5.5\text{V}$		+1.5/-1	± 1 ± 1 ± 1 ± 3 ± 20 ± 0.2 30			$\pm 1/2$ * ± 1 ± 0.5 * ± 10 ± 0.15 *	LSB LSB LSB mV mV mV % ppmFSR/V
TEMPERATURE DRIFT Gain Drift Unipolar, Bipolar Unipolar Offset Drift Bipolar Zero Drift			± 5 ± 0.1 ± 5	± 30 ± 5 ± 15		*	± 20 * ± 8	ppm/ $^{\circ}\text{C}$ ppmFSR/ $^{\circ}\text{C}$ ppmFSR/ $^{\circ}\text{C}$
REFERENCE OUTPUT Output Voltage Reference Drift Output Current Max Load Capacitance (For Stability) Short Circuit Current Load Regulation (ΔV_{OUT} vs ΔI_{LOAD}) Supply Regulation (ΔV_{OUT} vs ΔV_S) INVERTER -10V Reference ⁽⁴⁾ , Inverter Output -10V Reference Drift DC Output Impedance Output Current Max Load Capacitance (For Stability) Short Circuit Current	$T_A = 25^{\circ}\text{C}$ $T_A = -40^{\circ}\text{C}$ to $+85^{\circ}\text{C}$	+9.980 +10/-5 +6.5/-5	+10 ± 2 500 ± 20 40 ± 5	+10.020 ± 30 -9.980 ± 30	+9.985 * *	*	+10.015 ± 20 * -9.985 ± 20	V ppm/ $^{\circ}\text{C}$ mA mA pF mA ppm/mA ppm/V V ppm/ $^{\circ}\text{C}$ Ω mA pF mA
REFERENCE INPUT Reference Input Resistance Inverter Input Resistance BPO Input Resistance Reference Input Range		3.5 7 14	5 10 20	 ± 10	*	*	*	k Ω k Ω k Ω V
ANALOG SIGNAL OUTPUTS Voltage Range DC Output Impedance Output Current Max Load Capacitance (For Stability) Short Circuit Current	V_{OUT}	$-V_S + 1.4$ ± 5	0.1 500 ± 30	$+V_S - 1.4$	*	*	*	V Ω mA pF mA
DYNAMIC PERFORMANCE ⁽⁵⁾ Unipolar Mode Settling Time Bipolar Mode Settling Time Slew Rate Small-Signal Bandwidth	$C_L = 100\text{pF}$ To 1/2 LSB of Full Scale To 1/2 LSB of Full Scale		2.5 3.5 10 3	10 10	*	*	*	μs μs V/ μs MHz
ANALOG GROUND CURRENT (Code Dependent)			± 2			*		mA
DIGITAL CROSSTALK	Full Scale Transition $C_L = 100\text{pF}$		3			*		nV-s
D/A GLITCH IMPULSE			30			*		nV-s

SPECIFICATIONS (CONT), Guaranteed over $T_A = -40^{\circ}\text{C}$ to $+85^{\circ}\text{C}$ unless otherwise specified.

ELECTRICAL

Specifications as shown for $V_S = \pm 12\text{V}$ or $\pm 15\text{V}$, $V_L = +5\text{V}$, and $R_L = 2\text{k}\Omega$ unless otherwise noted.

PARAMETER	CONDITIONS	DAC2814AP			DAC2814BP			UNITS
		MIN	TYP	MAX	MIN	TYP	MAX	
POWER SUPPLY								
$+V_S$ and $-V_S$		± 11.4	± 15	± 18	*	*	*	V
$+V_L$		4.5	5	5.5	*	*	*	V
$+I_S$			+10	+13.5	*	*	*	mA
$-I_S$			-10	-13.5	*	*	*	mA
$+I_L$	Digital Inputs = 0V or $+V_L$		0.2	1	*	*	*	mA
$+I_L$	Digital Inputs = V_{IL} or V_{IH}			5	*	*	*	mA
Total Power, All DACs			300	410	*	*	*	mW
TEMPERATURE RANGE								
Specified		-40		+85	*		*	$^{\circ}\text{C}$
Operating		-40		+85	*		*	$^{\circ}\text{C}$
Thermal Resistance θ_{JA}			75			*		$^{\circ}\text{C}/\text{W}$

NOTES: (1) End point linearity. (2) Guaranteed monotonic. (3) Change in bipolar full scale output. Includes voltage output DAC, voltage reference, and reference inverter. (4) Inverter output with inverter input connected to $+V_{REF}$. (5) Guaranteed but not tested.

ABSOLUTE MAXIMUM RATINGS

$+V_L$ to AGND	0V, +7V
$+V_L$ to DGND	0V, +7V
$+V_S$ to AGND	0V, +18V
$-V_S$ to AGND	0V, -18V
AGND to DGND	$\pm 0.3\text{V}$
Any digital input to DGND	-0.3V, $+V_L + 0.3\text{V}$
Ref In to AGND	$\pm 25\text{V}$
Ref In to DGND	$\pm 25\text{V}$
Storage Temperature Range	-55°C to $+125^{\circ}\text{C}$
Operating Temperature Range	-40°C to $+85^{\circ}\text{C}$
Lead Temperature (soldering, 10s)	$+300^{\circ}\text{C}$
Junction Temperature	$+155^{\circ}\text{C}$
Output Short Circuit	Continuous to common or $\pm V_S$
Reference Short Circuit	Continuous to common or $+V_S$

PACKAGE INFORMATION

MODEL	PACKAGE	PACKAGE DRAWING NUMBER ⁽¹⁾
DAC2814AP	24-Pin Plastic DIP	167
DAC2814BP	24-Pin Plastic DIP	167

NOTE: (1) For detailed drawing and dimension table, please see end of data sheet, or Appendix D of Burr-Brown IC Data Book.



ELECTROSTATIC DISCHARGE SENSITIVITY

Electrostatic discharge can cause damage ranging from performance degradation to complete device failure. Burr-Brown Corporation recommends that all integrated circuits be handled and stored using appropriate ESD protection methods.

The information provided herein is believed to be reliable; however, BURR-BROWN assumes no responsibility for inaccuracies or omissions. BURR-BROWN assumes no responsibility for the use of this information, and all use of such information shall be entirely at the user's own risk. Prices and specifications are subject to change without notice. No patent rights or licenses to any of the circuits described herein are implied or granted to any third party. BURR-BROWN does not authorize or warrant any BURR-BROWN product for use in life support devices and/or systems.

PIN DESIGNATIONS

PIN	DESCRIPTOR	FUNCTION	PIN	DESCRIPTOR	FUNCTION
1	DGND	Digital common	24	$\overline{\text{CS}}$	Chip select enable, DAC A and DAC B
2	$\overline{\text{LATCH B}}$	Latch data update, logic input, DAC B	23	Data In	Serial data input
3	$\overline{\text{CLR}}$	Asynchronous input reset to zero	22	$\overline{\text{LATCH A}}$	Latch data update, logic input, DAC A
4	MODE	Selection input for unipolar or bipolar reset to zero	21	CLK	Clock input
5	Data Out	Serial data output	20	NC	No internal connection
6	$+V_L$	Positive logic power supply, +5V input	19	BPO A	Bipolar offset input, DAC A
7	$-V_S$	Negative analog power supply, -15V input	18	BPO B	Bipolar offset input, DAC B
8	AGND	Analog common	17	$V_{\text{OUT B}}$	Analog output voltage, DAC B
9	NC	No internal connection	16	$+V_{\text{REF Out}}$	Reference voltage, +10V output
10	$+V_S$	Positive analog power supply, +15V input	15	Inv In	Inverter (A3) input
11	$V_{\text{REF In}}$	\pm Reference voltage input	14	$V_{\text{OUT A}}$	Analog output voltage, DAC A
12	Inv Out	Inverter (A3) output	13	NC	No internal connection

PIN CONFIGURATIONS

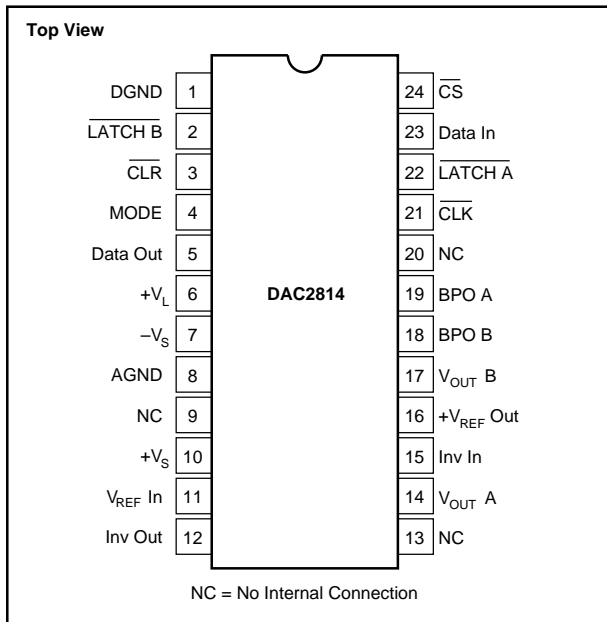

TYPICAL PERFORMANCE CURVES

$T_A = +25^\circ\text{C}$, $V_S = \pm 12\text{V}$ or $\pm 15\text{V}$, $V_L = +5\text{V}$ unless otherwise noted.

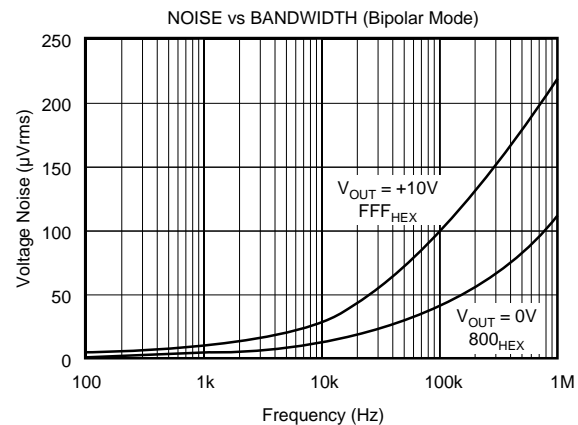
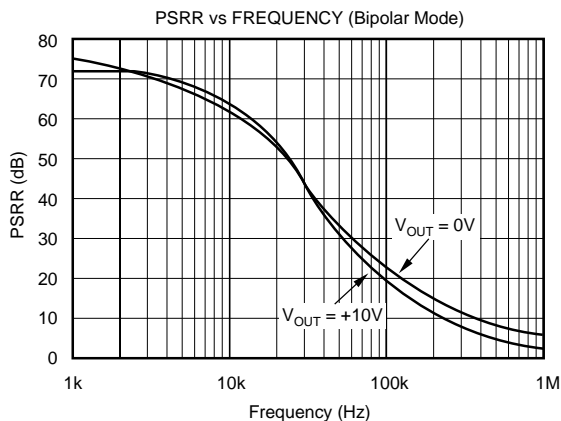

TYPICAL PERFORMANCE CURVES (CONT)

$T_A = +25^\circ\text{C}$, $V_S = \pm 12\text{V}$ or $\pm 15\text{V}$, $V_L = +5\text{V}$ unless otherwise noted.

CHANGE OF GAIN, BIPOLAR OFFSET AND ZERO ERROR vs TEMPERATURE

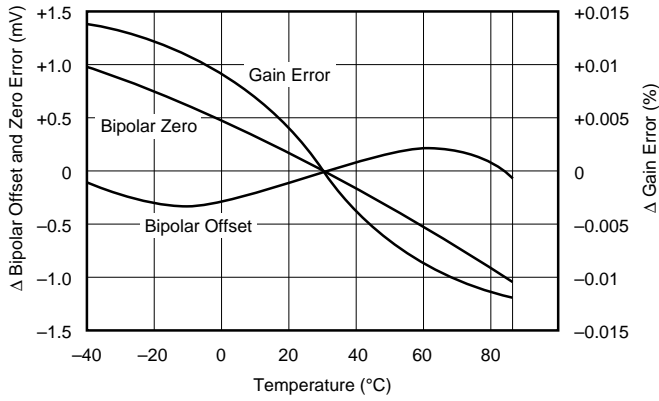

POWER SUPPLY CURRENT vs TEMPERATURE

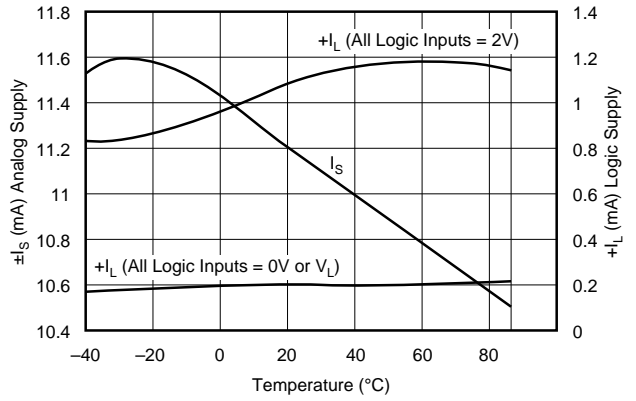

OUTPUT VOLTAGE SWING vs RESISTOR LOAD

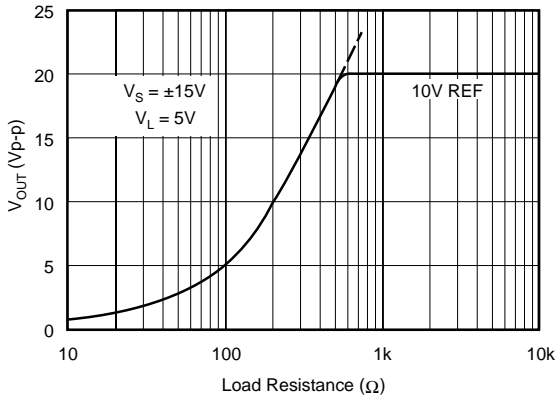

CROSSTALK (Bipolar Mode)

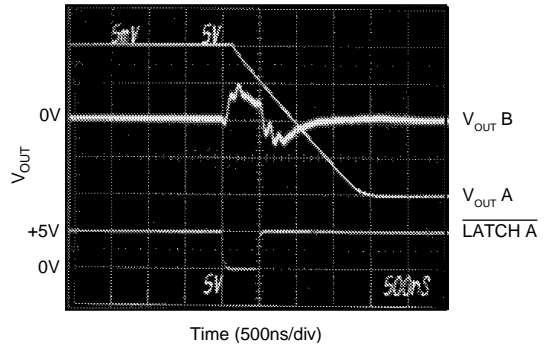

NOTE: Crosstalk is dominated by digital crosstalk/feedthrough of the LATCH signal.

FULL-SCALE OUTPUT SWING BIPOLAR (20V Step)

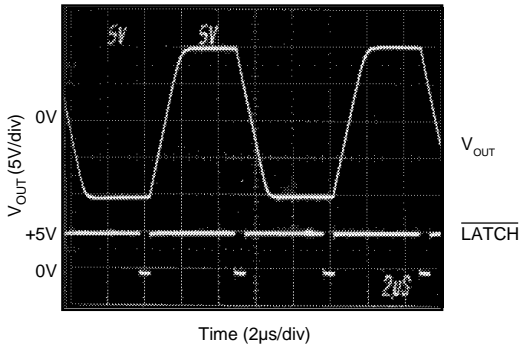

FULL-SCALE OUTPUT SWING UNIPOLAR (10V Step)

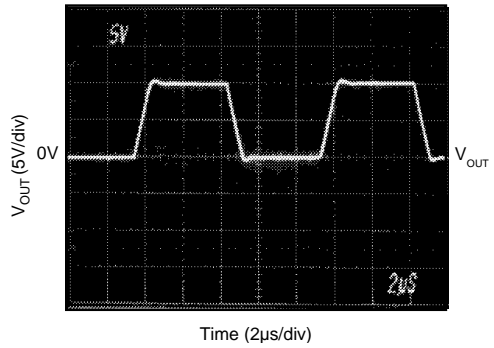

TYPICAL PERFORMANCE CURVES (CONT)

$T_A = +25^\circ\text{C}$, $V_S = \pm 12\text{V}$ or $\pm 15\text{V}$, $V_L = +5\text{V}$ unless otherwise noted.

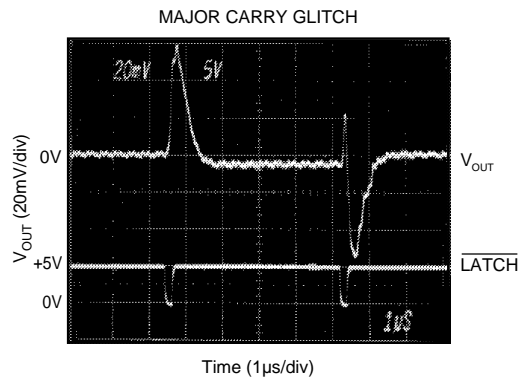
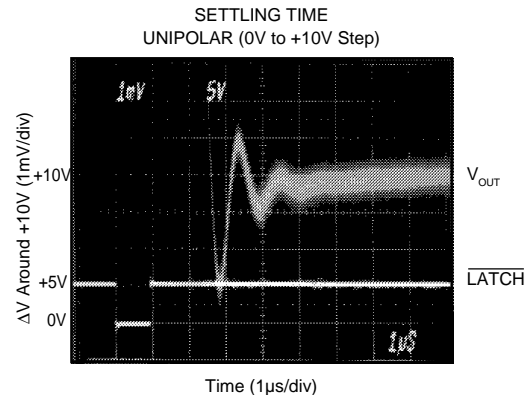
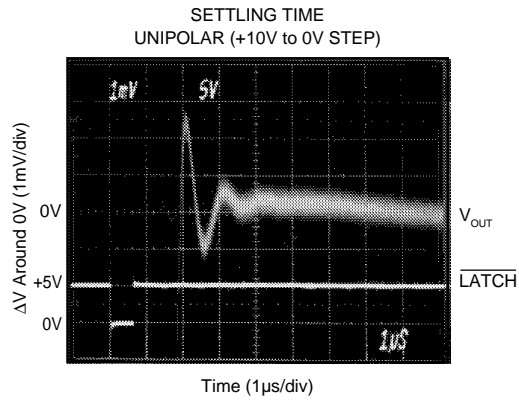
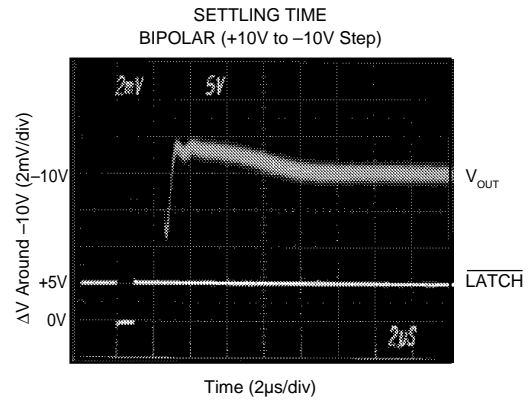
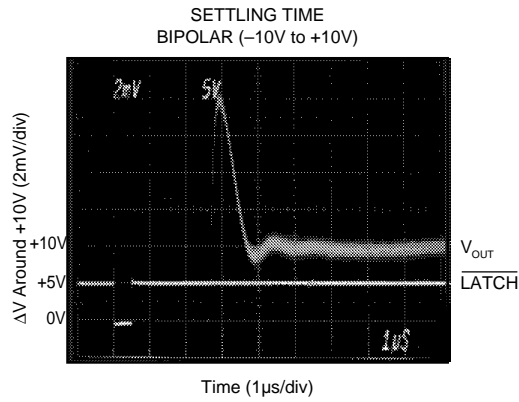

NOTE: Data transition 800_{HEX} to 7FF_{HEX}.

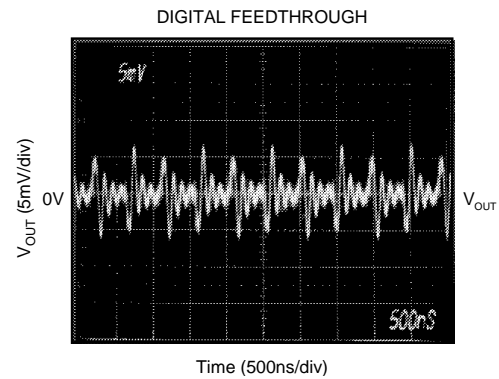

DAC output noise due to activity on digital inputs with latch disabled.

TIMING CHARACTERISTICS

$V_L = +5V$, $T_A = -40^\circ\text{C}$ to $+85^\circ\text{C}$.

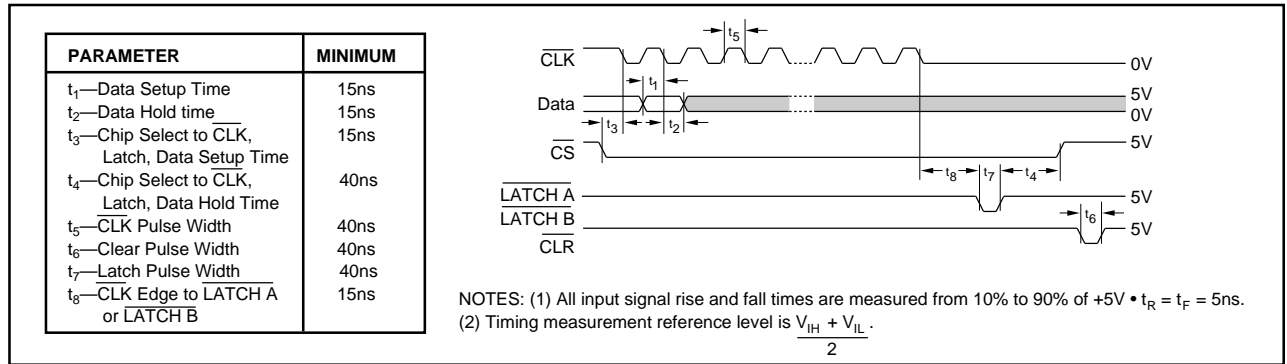

INTERFACE LOGIC TRUTH TABLE

MODE	$\overline{\text{CLR}}$	$\overline{\text{CLK}}$	$\overline{\text{CS}}$	LATCH A	LATCH B	FUNCTION
X	1	↓	0	X	X	Data Clocked In
X	1	X	1	X	X	No Data Transfer
X	1	X	0	0	1	DAC A Register Updated
X	1	X	0	1	0	DAC B Register Updated
X	1	X	0	0	0	DAC A and DAC B Updated Together
0	0	X	X	X	X	All Registers Cleared
1	0	X	X	X	X	Shift Registers Cleared = 000 _{HEX} , DAC Registers = 800 _{HEX}

NOTE: X = Don't care ↓ = Falling edge triggered.

FUNCTIONAL BLOCK DIAGRAM , DAC2814 — Dual, 12-bit DAC, Serial Port

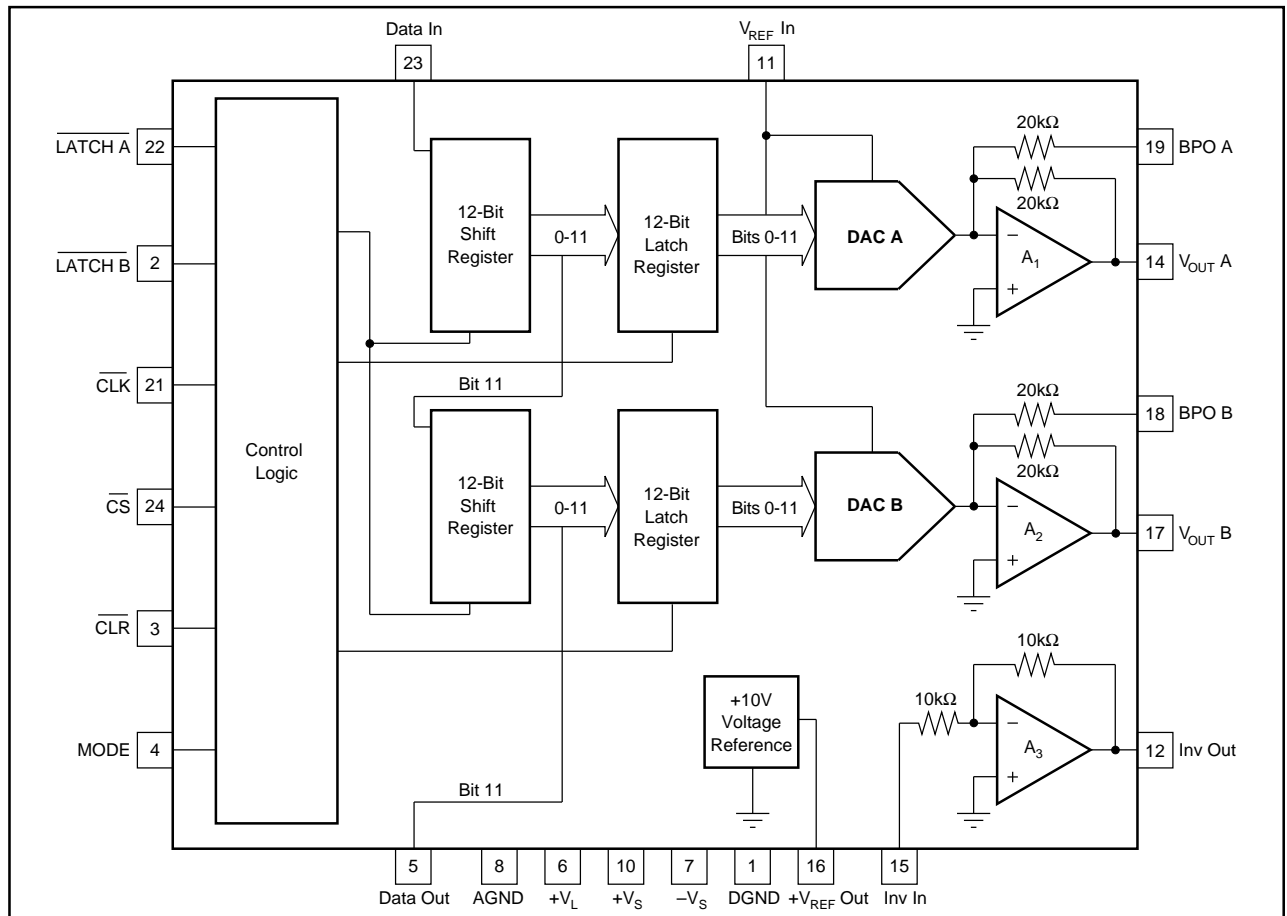

DISCUSSION OF SPECIFICATIONS

INPUT CODES

All digital inputs of the DAC2814 are TTL and 5V CMOS compatible. Input codes for the DAC2814 are either USB (Unipolar Straight Binary) or BOB (Bipolar Offset Binary) depending on the mode of operation. See Figure 3 for $\pm 10V$ bipolar connection. See Figures 4 and 5 for 0 to 10V and 0 to $-10V$ unipolar connections.

UNIPOLAR AND BIPOLAR OUTPUTS FOR SELECTED INPUT

DIGITAL INPUT	UNIPOLAR (USB)	BIPOLAR (BOB)
FFF _{HEX}	+Full scale	+Full scale
800 _{HEX}	+1/2 Full scale	Zero
7FF _{HEX}	+1/2 Full scale - 1 LSB	Zero - 1 LSB
000 _{HEX}	Zero	-Full scale

INTEGRAL OR RELATIVE LINEARITY

This term, also known as end point linearity, describes the transfer function of analog output to digital input code. Integral linearity error is the deviation of the analog output versus code transfer function from a straight line drawn through the end points.

DIFFERENTIAL NONLINEARITY

Differential nonlinearity is the deviation from an ideal 1 LSB change in the output voltage when the input code changes by 1 LSB. A differential nonlinearity specification of ± 1 LSB maximum guarantees monotonicity.

UNIPOLAR OFFSET ERROR

The output voltage for code 000_{HEX} when the DAC is in unipolar mode of operation.

BIPOLAR ZERO ERROR

The output voltage for code 800_{HEX} when the DAC is in the bipolar mode of operation.

GAIN ERROR

The deviation of the output voltage span ($V_{MAX} - V_{MIN}$) from the ideal span of $10V - 1$ LSB (unipolar mode) or $20V - 1$ LSB (bipolar mode). The gain error is specified with and without the internal $+10V$ reference error included.

OUTPUT SETTLING TIME

The time required for the output voltage to settle within a percentage-of-full-scale error band for a full scale transition. Settling to $\pm 0.012\%$ (1/2 LSB) is specified for the DAC2814.

DIGITAL-TO-ANALOG GLITCH

Ideally, the DAC output would make a clean step change in response to an input code change. In reality glitches occur during the transition. See Typical Performance Curves.

DIGITAL CROSSTALK

Digital crosstalk is the glitch impulse measured at the output of one DAC due to a full scale transition on the other DAC—see Typical Performance Curves. It is dominated by digital coupling. Also, the integrated area of the glitch pulse is specified in nV-s. See table of electrical specifications.

DIGITAL FEEDTHROUGH

Digital feedthrough is the noise at a DAC output due to activity on the digital inputs—see Typical Performance Curves.

OPERATION

DACs can be updated simultaneously or independently as required. Data are transferred on falling clock edges into a 24-bit shift register. DAC B MSB is loaded first. Data are transferred to the DAC registers when the \overline{LATCH} signals are brought low. The data are latched when the \overline{LATCH} signals are brought high. Both \overline{LATCH} signals may be tied together to allow simultaneous update of the DACs if required. The output of the DAC shift register is provided to allow cascading of several DACs on the same bit stream.

By using separate signals for $\overline{LATCH A}$ and $\overline{LATCH B}$, it is possible to update either one of the two DACs every 12 clock cycles.

When \overline{CLR} is brought low, the input shift registers are cleared to 000_{HEX}, while the DAC registers = 800_{HEX}. If \overline{LATCH} is brought low after \overline{CLR} , the DACs are updated with 000_{HEX} resulting in $-10V$ (Bipolar) or $0V$ (Unipolar) on the output.

CIRCUIT DESCRIPTION

Each of the two DACs in the DAC2814 consists of a CMOS logic section, a CMOS DAC cell, and an output amplifier. One buried-zener $+10.0V$ reference and a reference inverter (for a $-10.0V$ reference) are shared by both DACs.

Figure 1 is a simplified circuit for a DAC cell. An R, 2R ladder network is driven by a voltage reference at V_{REF} . Current from the ladder is switched either to I_{OUT} or AGND by 12 single-pole double-throw CMOS switches. This maintains constant current in each leg of the ladder regardless of digital input code. This makes the resistance at V_{REF} constant (it can be driven by either a voltage or current reference). The reference can be either positive or negative polarity with a range of up to $\pm 10V$.

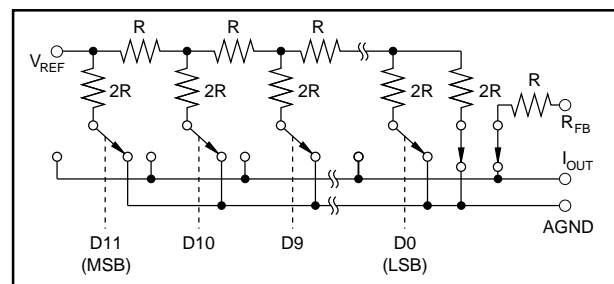

FIGURE 1. Simplified Circuit Diagram of DAC Cell.

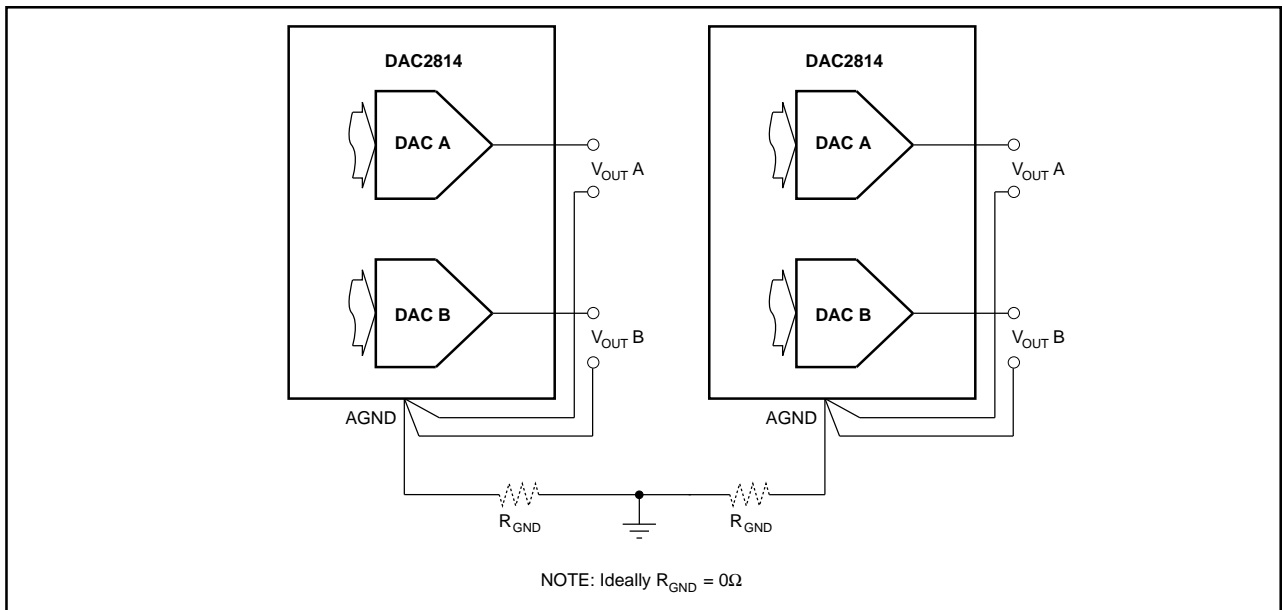

FIGURE 2. Recommended Ground Connections for Multiple DAC packages.

CMOS switches included in series with the ladder terminating resistor and the feedback resistor, R_{FB} , compensate for the temperature drift of the ladder switch ON resistance.

The output op amps are connected as transimpedance amplifiers to convert the DAC-cell output current into an output voltage. They have been specially designed and compensated for precision and fast settling in this application.

POWER SUPPLY CONNECTIONS

The DAC2814 is specified for operation with power supplies of $V_L = +5V$ and $V_S =$ either $\pm 12V$ or $\pm 15V$. Even with the V_S supplies at $\pm 11.4V$ the DACs can swing a full $\pm 10V$. Power supply decoupling capacitors ($1\mu F$ tantalum) should be located close to the DAC power supply connections.

Separate digital and analog ground pins are provided to permit separate current returns. They should be connected together at one point. Proper layout of the two current returns will prevent digital logic switching currents from degrading the analog output signal. The analog ground current is code dependent so the impedance to the system reference ground must be kept to a minimum. Connect DACs as shown in Figure 2 or use a ground plane to keep ground impedance less than 0.1Ω for less than 0.1LSB error.

-10V REFERENCE

An internal inverting amplifier (Gain = $-1.0V/V$) is provided to invert the $+10V$ reference. Connect $+V_{REF}$ Out to Inv In for a $-10V$ reference at Inv Out.

OUTPUT RANGE CONNECTIONS

$\pm 10V$ Output Range

For a $\pm 10V$ bipolar outputs connect the DAC2814 as shown in Figure 3. Connect the MODE to logic high ($+5V$) for reset to bipolar zero. With MODE connected low (GND) reset will be to $-Full-Scale$.

0 To $+10V$ Output Range

For 0 to $+10V$ unipolar outputs connect the DAC2814 as shown in Figure 4. Connect the MODE to logic low (GND) for reset to unipolar zero.

0 To $-10V$ Output Range

For 0 to $-10V$ unipolar outputs connect the DAC2814 as shown in Figure 5. Connect the MODE to logic low (GND) for reset to unipolar zero.

CONNECTION TO DIGITAL BUS

Cascaded Bus Connection

Multiple DAC2814s can be connected to the same \overline{CLK} and DATA input lines in two ways. Since the output of the DAC shift register is available, any number of DAC2814s can be cascaded on the same input bit stream as shown in Figure 6. This arrangement allows all DACs in the system to be updated simultaneously and requires a minimum number of control signal inputs. However, up to $24N$ CLK cycles may be required to update any given DAC, where $N =$ number of DAC2814s.

Parallel Bus Connection

Several DAC2814s can also have their DATA inputs connected in parallel as shown in Figure 7. This allows any DAC in the system to be updated in a maximum of 24 CLK cycles.

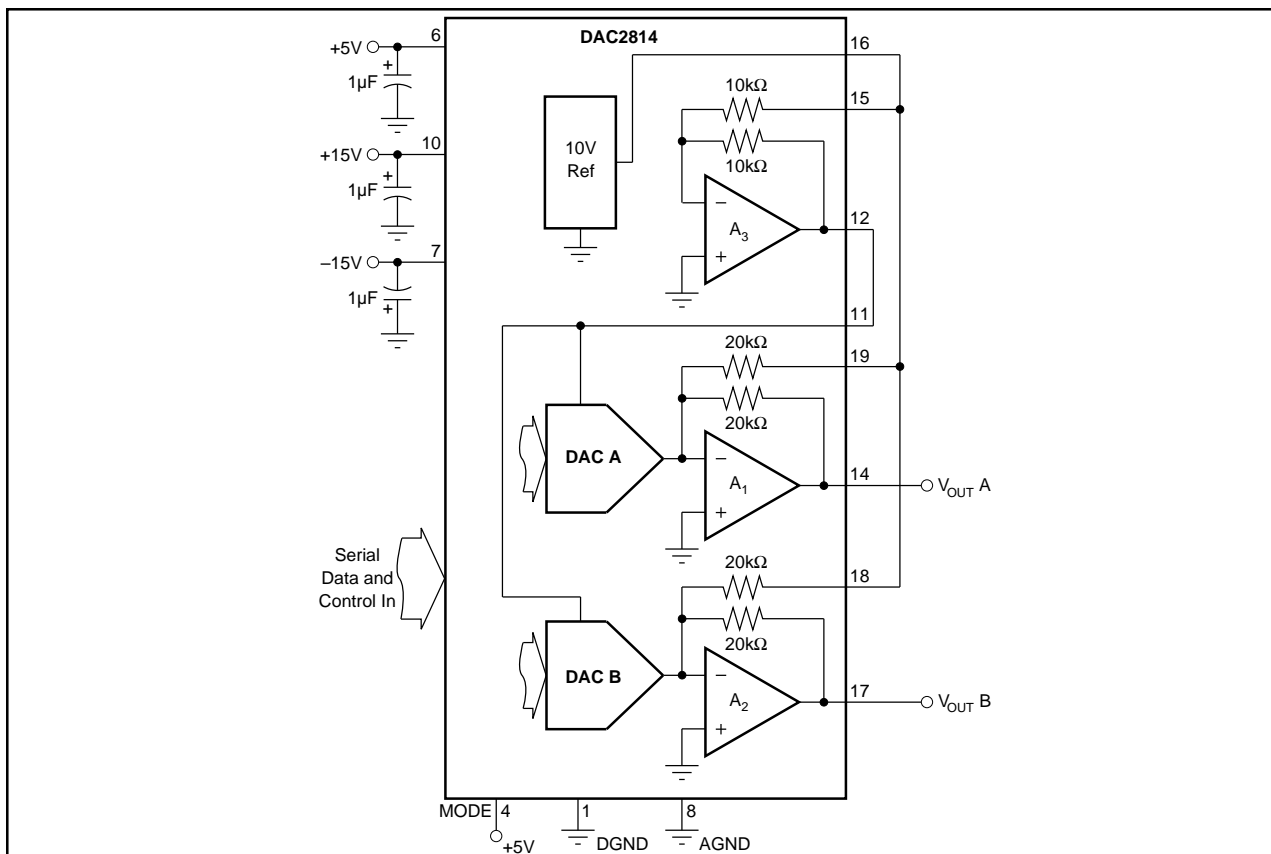

FIGURE 3. Analog Connections for $\pm 10\text{V}$ DAC Output.

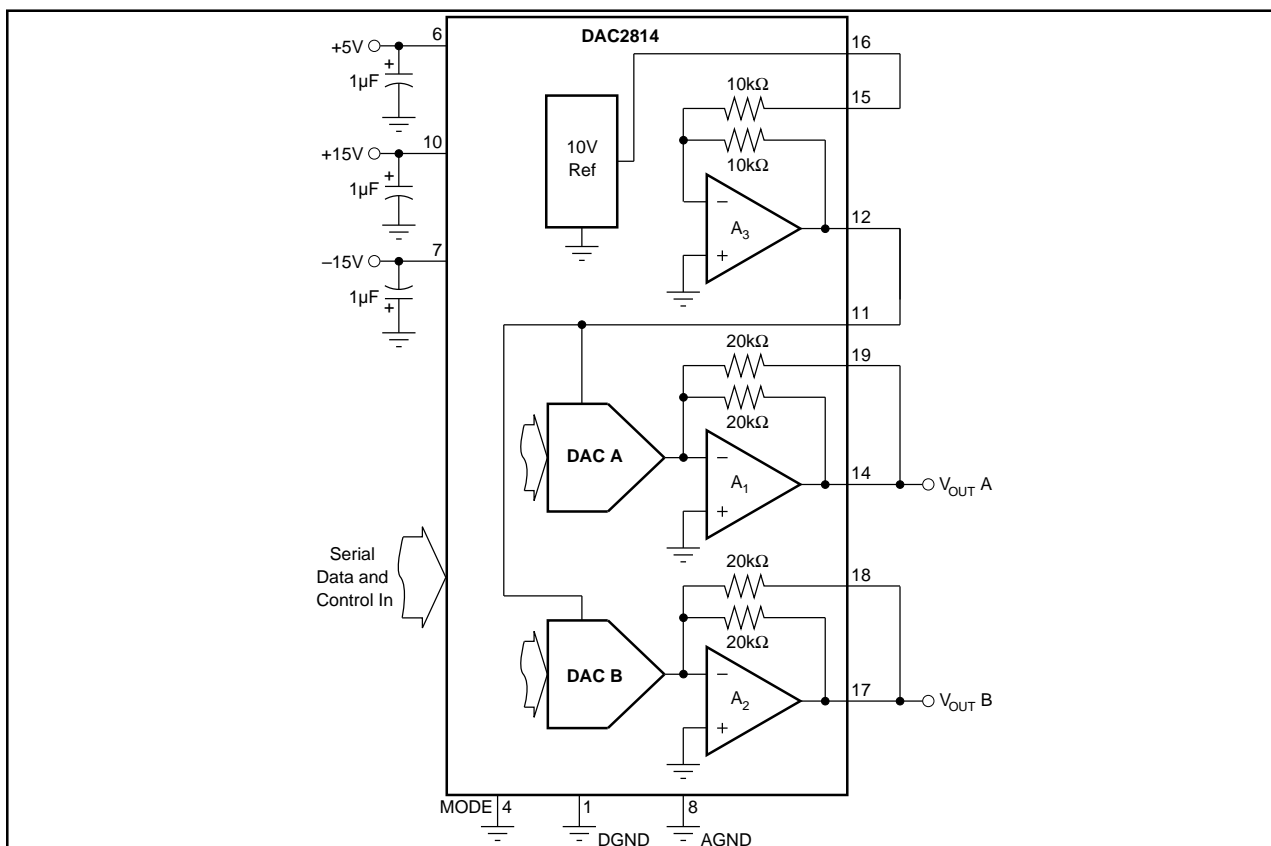

FIGURE 4. Analog Connections for 0 to $+10\text{V}$ DAC Output.

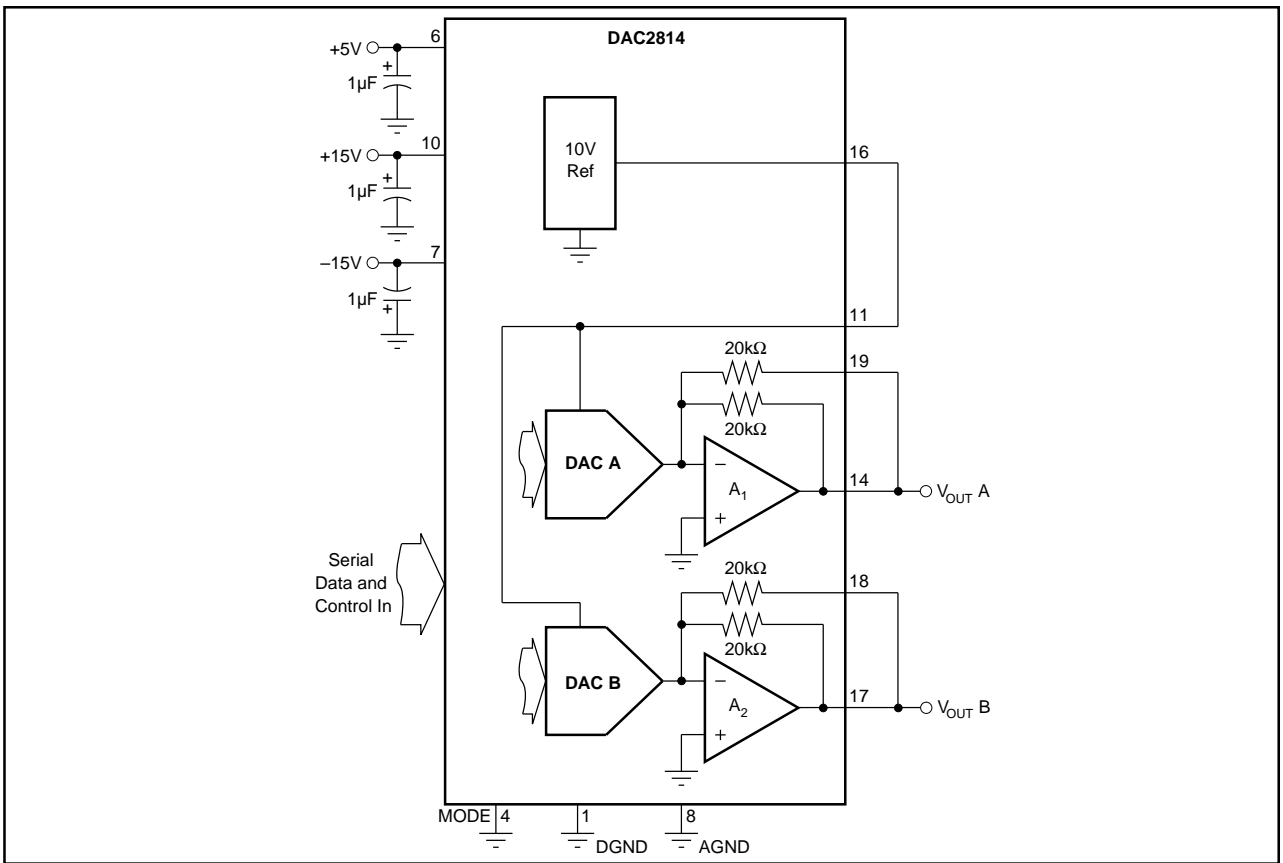

FIGURE 5. Analog Connections for 0 to -10V DAC Output.

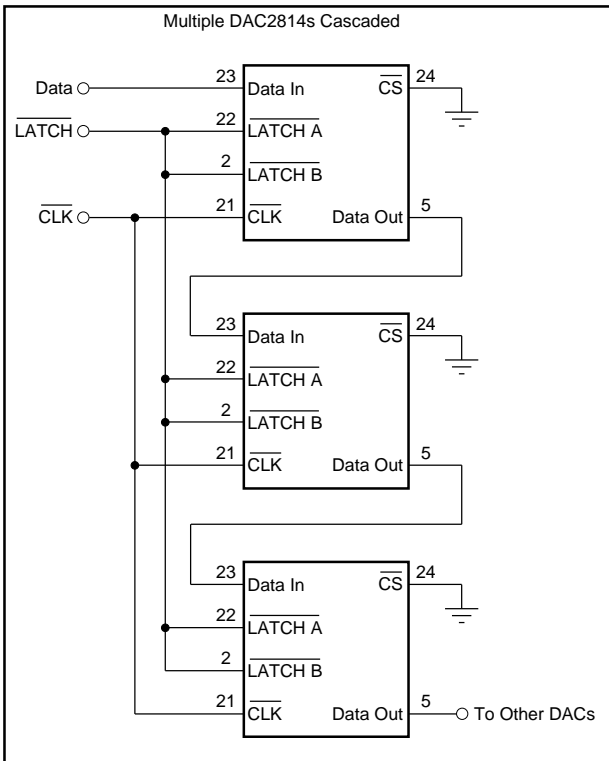

FIGURE 6. Cascaded Serial Bus Connection for Multiple DAC packages.

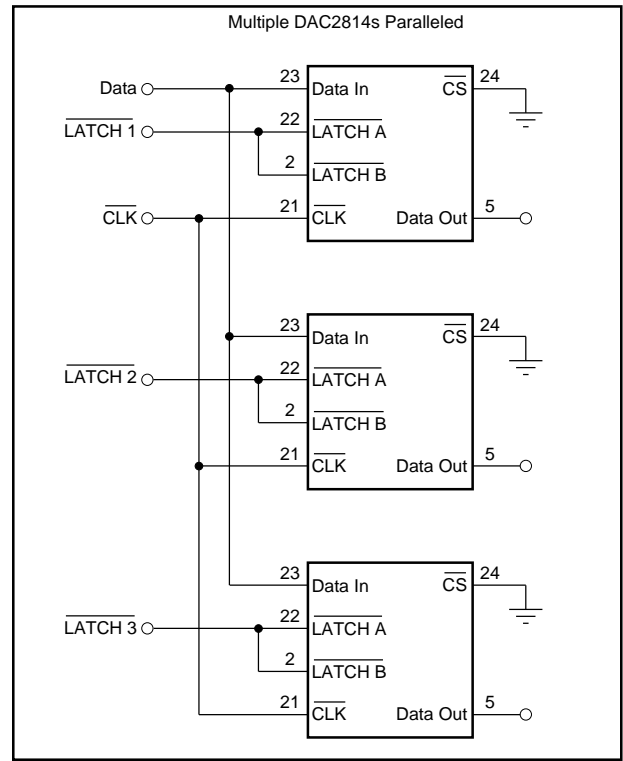

FIGURE 7. Parallel Bus Connection for Multiple DAC packages.

IMPORTANT NOTICE

Texas Instruments and its subsidiaries (TI) reserve the right to make changes to their products or to discontinue any product or service without notice, and advise customers to obtain the latest version of relevant information to verify, before placing orders, that information being relied on is current and complete. All products are sold subject to the terms and conditions of sale supplied at the time of order acknowledgment, including those pertaining to warranty, patent infringement, and limitation of liability.

TI warrants performance of its semiconductor products to the specifications applicable at the time of sale in accordance with TI's standard warranty. Testing and other quality control techniques are utilized to the extent TI deems necessary to support this warranty. Specific testing of all parameters of each device is not necessarily performed, except those mandated by government requirements.

Customers are responsible for their applications using TI components.

In order to minimize risks associated with the customer's applications, adequate design and operating safeguards must be provided by the customer to minimize inherent or procedural hazards.

TI assumes no liability for applications assistance or customer product design. TI does not warrant or represent that any license, either express or implied, is granted under any patent right, copyright, mask work right, or other intellectual property right of TI covering or relating to any combination, machine, or process in which such semiconductor products or services might be or are used. TI's publication of information regarding any third party's products or services does not constitute TI's approval, warranty or endorsement thereof.