



DS35F87/DS34F87 RS-422 Quad Line Driver with TRI-STATE® Outputs

General Description

The DS34F87/DS35F87 RS-422 Quad Line Driver features four independent driver chains which comply with EIA Standards for the electrical characteristics of balanced voltages digital interface circuits. The outputs are TRI-STATE structures which are forced to a high impedance state when the appropriate output control lead reaches a logic zero condition. All input leads are PNP buffered to minimize input loading for either logic one or logic zero inputs. In addition, internal circuitry assures a high impedance output state during the transition between power-up and power-down.

The DS34F87/DS35F87 offers improved performance due to the use of state-of-the-art L-FAST bipolar technology. The L-FAST technology allows for higher speeds and lower currents by utilizing extremely short gate delay times. Thus, the DS34F87/DS35F87 features lower power, extended temperature range, and improved specifications.

The DS34F87/DS35F87 offers optimum performance when used with the DS34F86/DS35F86 Quad Line Receiver.

Features

- Military temperature range
- Four independent driver chains
- TRI-STATE outputs
- PNP high impedance inputs
- Fast propagation time
- TTL compatible
- Single 5.0V supply voltage
- Output rise and falls times less than 20 ns
- Lead compatible and interchangeable with MC3487 and DS3487

Block and Connection Diagrams

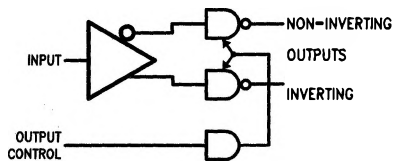
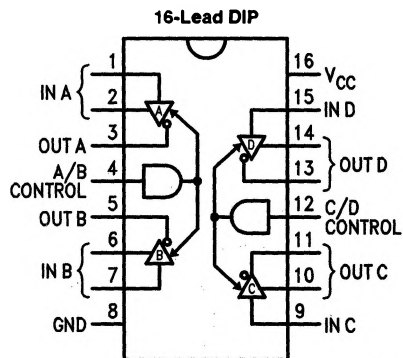

FIGURE 1

TL/F/9618-2



Top View

TL/F/9618-1

Function Table (Each Driver)

Input	Enable	Output	
		Y	Z
H	H	H	L
L	H	L	H
X	L	Z	Z

H = High Level
L = Low Level
X = Immaterial
Z = High Impedance (off)

Order Number DS34F87J or DS35F87J
See NS Package Number J16A