

## DEFLECTION PROCESSOR FOR CRT DISPLAY

The KA2138 is a monolithic integrated circuit encapsulated in a 20 dual-in-line package designed for vertical, horizontal deflection signal processing for a CRT display.

This IC can be connected to the KA2131 (for vertical output use) to form a deflection processing that uses every requirement for a CRT display.

## FUNCTIONS

### [Vertical Block]

- Vertical oscillator & Ramp generator
- Sampling type DC voltage control within retrace time

### [Horizontal Block]

- Horizontal oscillator & AFC
- X-ray protector
- AFC sawtooth wave generator
- Horizontal pulse duty setting
- Horizontal phase shifter

## FEATURES

- Vertical pull-in range 20Hz permits non-adjusting at vertical synchronizing 50Hz or 60Hz.
- Good vertical linearity because DC supplying at the vertical output stage is subjected to sampling type control during retrace time
- The horizontal oscillation frequency is stable from 15KHz to 100KHz.
- The horizontal display can be shifted right or left
- The horizontal/vertical synchronizing pulse input can be used intact regardless of the difference in pulse polarity and pulse width.
- The AFC feedback sawtooth wave can be obtained by simply applying a flyback pulse to the IC as a trigger pulse
- Any duty of horizontal pulse can be set

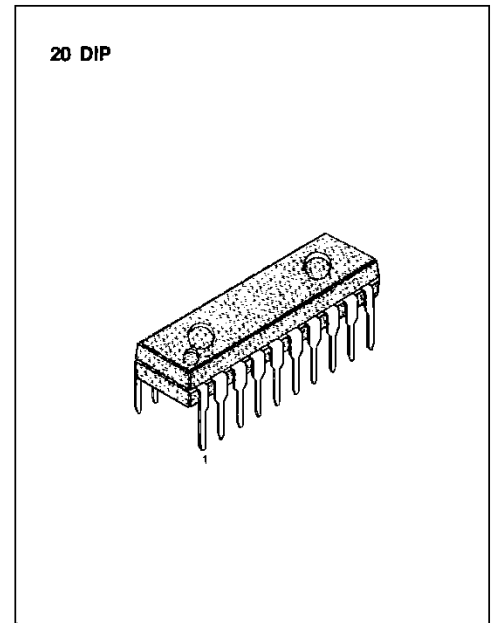

## ORDERING INFORMATION

Device	Package	Operating Temperature
KA2138N	20 DPI	-20 ~ +70°C

## BLOCK DIAGRAM

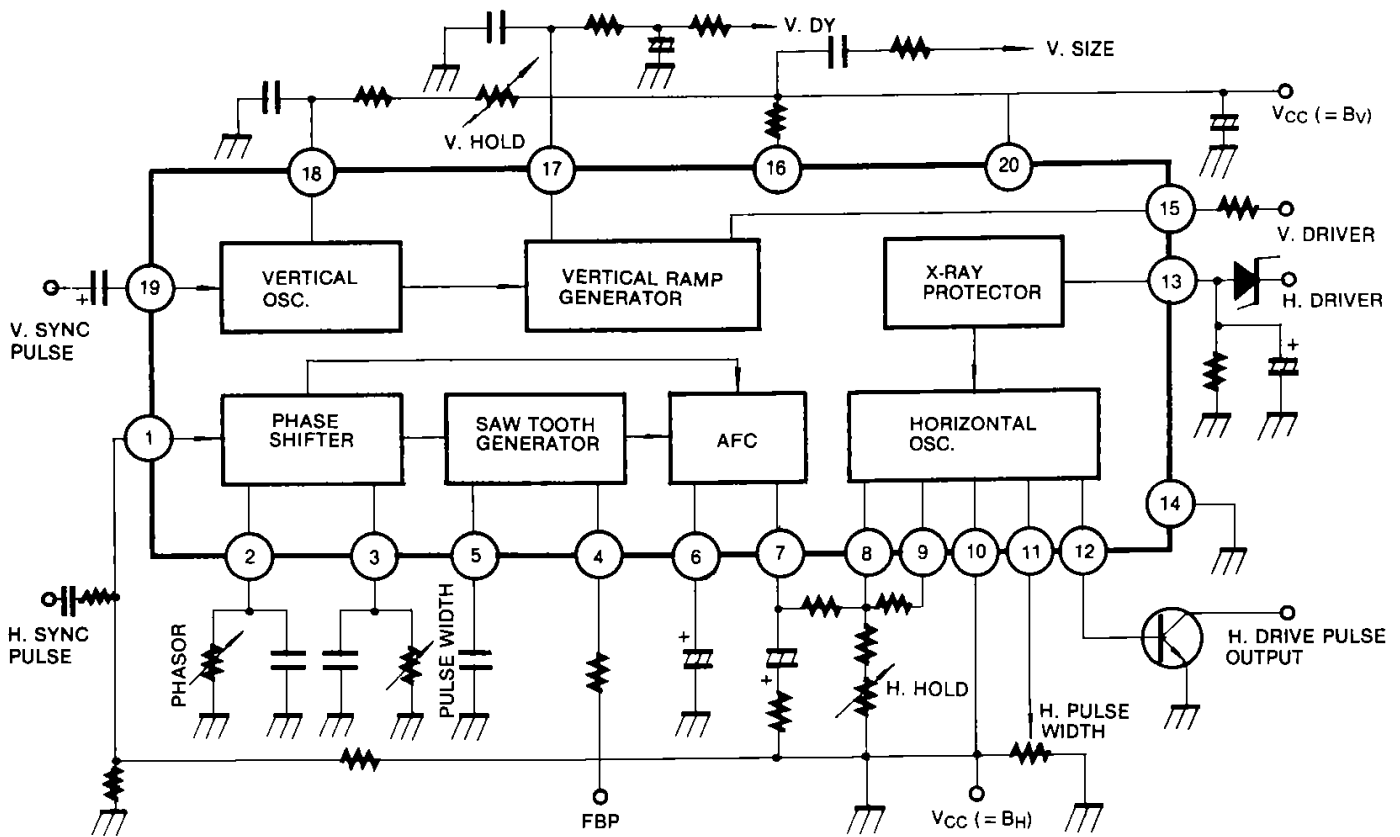

Fig. 1

## ABSOLUTE MAXIMUM RATINGS ( $T_a = 25^\circ\text{C}$ )

Characteristic	Symbol	Value	Unit
Supply Voltage	$V_{10(\max)}, V_{20(\max)}$	14	V
Power Dissipation	$P_D$	780	mW
Operating Temperature	$T_{\text{OPR}}$	-20 ~ +70	$^\circ\text{C}$
Storage Temperature	$T_{\text{STG}}$	-55 ~ +150	$^\circ\text{C}$

## RECOMMENDED OPERATING CONDITIONS ( $T_a = 25^\circ\text{C}$ )

Characteristic	Symbol	Min	Typ	Max	Unit
Supply Voltage	$V_{10}, V_{20}$	9	12	13.5	V
Vert. Pulse Voltage	$V_V$	2.0	5.0	6.0	$V_{\text{p-p}}$
Horiz. Pulse Voltage	$V_H$	2.0	5.0	6.0	$V_{\text{p-p}}$

**ELECTRICAL CHARACTERISTICS ( $V_{CC10} = V_{CC20} = 12V$ ,  $T_a = 25^\circ C$ )**

Characteristic	Symbol	Test Conditions	Min	Typ	Max	Unit
Quiescent Current	$I_{10}$	$V_{CC10} = 12V$	12		30	mA
	$I_{20}$	$V_{CC20} = 12V$	5		12	mA

**Vertical Part**

Pull-In Range	$f_{V(PULL)}$	Synchronizing pulse frequency 60Hz	21	23		Hz
Free-Running Frequency	$f_V$		55	60	65	Hz
Frequency Drift with Supply Voltage	$\Delta f_V/V_{CC}$	$V_{20} = 12 \pm 1V$ , 60Hz at 12V	-0.1		0.1	Hz
Center Voltage Control Threshold Level			3.8		4.4	V
Frequency Drift with Ambient Temperature	$\Delta f_{(V)}$	$T_a = -10$ to $+60^\circ C$	-0.028		0.028	Hz/ $^\circ C$
Oscillation Start Voltage	$V_{OSC(V)}$				4.0	V
Driver Amplification Factor	$\Delta A_V$		12		18	dB

**Horizontal Part**

Oscillation Start Voltage	$V_{OSC(H)}$				4.0	V
Free-Running Frequency	$f_H$	$f_H = 15.734KHz$	-750		750	Hz
AFC DC Loop Current	$I_{AFC}$		$\pm 0.85$		$\pm 1.6$	mA
Frequency Drift with Supply Voltage	$\Delta f_H/V_{CC}$	$V_{10} = 12 \pm 1V$ , 15.734KHz at 12V	-50		50	Hz
Frequency Drift with Ambient Temperature	$\Delta f_V/T_A$	$T_a = -10$ to $+60^\circ C$	-2.9		2.9	Hz/ $^\circ C$
Comparison Wave Shaping Input Voltage	$V_4$		0.6		0.9	V
X-Ray Protector Starting Voltage	$V_{13}$		0.5		0.8	V
Horizontal Drive Current	$I_{12}$		6.0		12.0	mA

# TYPICAL APPLICATION CIRCUIT

14" color monitor ( $f_v$ : 60Hz,  $f_H$  = 15.734KHz)

