

# KA22426B

# AM/FM 1 CHIP RADIO

## INTRODUCTION

The KA22426B is a monolithic integrated circuit designed for radio-cassette tape recorders, clock radios and headphone radios.

## FUNCTIONS

- AM/FM RF AMP
- Local OSC
- AM AGC Control
- FM AFC Control
- Audio Power AMP
- Tuning Indicator
- DC Volume
- AM/FM IF AMP
- FM Quadrature DET
- AM DET

## FEATURES

- Built-in AM/FM Switching Circuit
- Wide operating supply voltage:  $V_{CC} = 2 \sim 8.5 \text{ V}$
- Low current consumption ( $V_{CC} = 3\text{V}$ )
  - FM:  $I_{CCQ} = 7.0\text{mA (tvP)}$
  - AM:  $I_{CCQ} = 3.5\text{mA (typ)}$
- High Power Audio Amplifier:  $0.5\text{W(typ)}$  at  $V_{CC} = 6\text{V}$ ,  $R_L = 8\Omega$ , THD = 10%

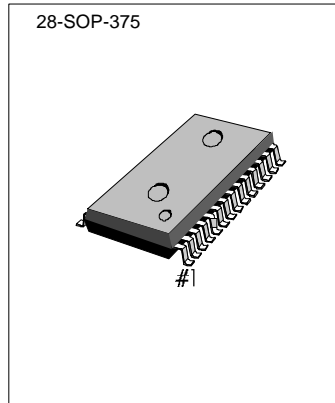

## ORDERING INFORMATION

Device	Package	Operating Temperature
KA22426BD	28-SOP-375	-20 ~ +70°C

## BLOCK DIAGRAM

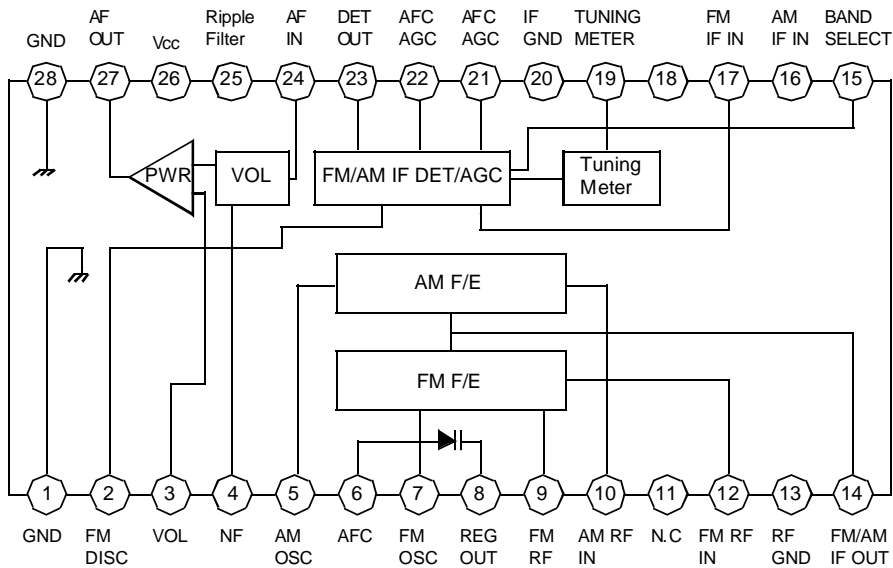

Fig. 1.

**ABSOLUTE MAXIMUM RATINGS (Ta 25°C)**

Characteristic	Symbol	Value	Unit
Supply Voltage	V <sub>CC</sub>	9	V
Power Dissipation	P <sub>D</sub>	1000	mW
Operating Temperature	T <sub>OPR</sub>	-20 ~ +70	°C
Storage Temperature	T <sub>STG</sub>	-40 ~ +125	°C

**ELECTRICAL CHARACTERISTICS**(V<sub>CC</sub> = 6V, Ta = 25°C, FM; Δf = 22.5KHz, fm = 1KHz, AM; 30% Mod unless otherwise specified)

	Characteristic	Symbol	Test Condition	Min	Typ	Max	Unit
FM	Quiescent Circuit Current	I <sub>CCQ</sub>	V <sub>i</sub> = 0		7.0	14.0	mA
	F/E Voltage Gain	G <sub>V1V</sub>	V <sub>i</sub> (1) = 40dBμ, f = 100MHz, Δf = 0	32	39	46	dB
	Detect Output Gain	V <sub>O</sub> (1)	V <sub>i</sub> (3) = 90dBμ, f = 10.7 MHz	-26	-20	-14	dBm
	IF-3dB Sensitivity	V <sub>I(LIM)</sub>	V <sub>O</sub> (V <sub>i</sub> 3) = 90dB-3dB, f = 10.7 MHz		24	32	dBμ
	Total Harmonic Distortion	THD <sub>1</sub>	V <sub>i</sub> (3) = 90dBμ, f = 10.7MHz (Δf = 75KHz)		0.3	2.0	%
	Meter Drive Current	I <sub>M</sub> (1)	V <sub>i</sub> (3) = 60dBμ, f = 10.7MHz	1.8	3.5	7.0	mA
AM	Quiescent Circuit Current	I <sub>CCQ</sub> (2)	V <sub>i</sub> = 0		3.5	10.0	mA
	F/E Voltage Gain	G <sub>V</sub> (2)	V <sub>i</sub> (2) = 60dBμ, f = 1660KHz, m=0%	15	22	29	dB
	IF Voltage Gain	G <sub>V</sub> (3)	V <sub>O</sub> (3) = -34dBm, f = 455kHz	14	20	27	dBμ
	AM Detect Output Voltage	V <sub>O</sub> (2)	V <sub>i</sub> (3) = 85dB, f = 455KHz	-26	-20	-14	dBm
	Total Harmonic Distortion	THD <sub>2</sub>	V <sub>i</sub> (2) = 95dBμ, f = 1660KHz, V <sub>CC</sub> =7.8V		0.6	2.0	%
	Meter Drive Current	I <sub>M</sub> (2)	V <sub>i</sub> (3) = 85dBμ, f = 455KHz	1.3	3.0	7.0	mA
AF	Closed Loop Voltage Gain	G <sub>V</sub> (4)	V <sub>O</sub> (4) = 0dBm, f = 1KHz	27	31.5	36	dB
	Total Harmonic Distortion	THD <sub>3</sub>	P <sub>O</sub> = 50mW, f = 1KHz		0.3	2.5	%
	Output Power	P <sub>O</sub>	R <sub>L</sub> = 8Ω, THD = 10%, f = 1KHz	0.4	0.5		W

APPLICATION CIRCUIT

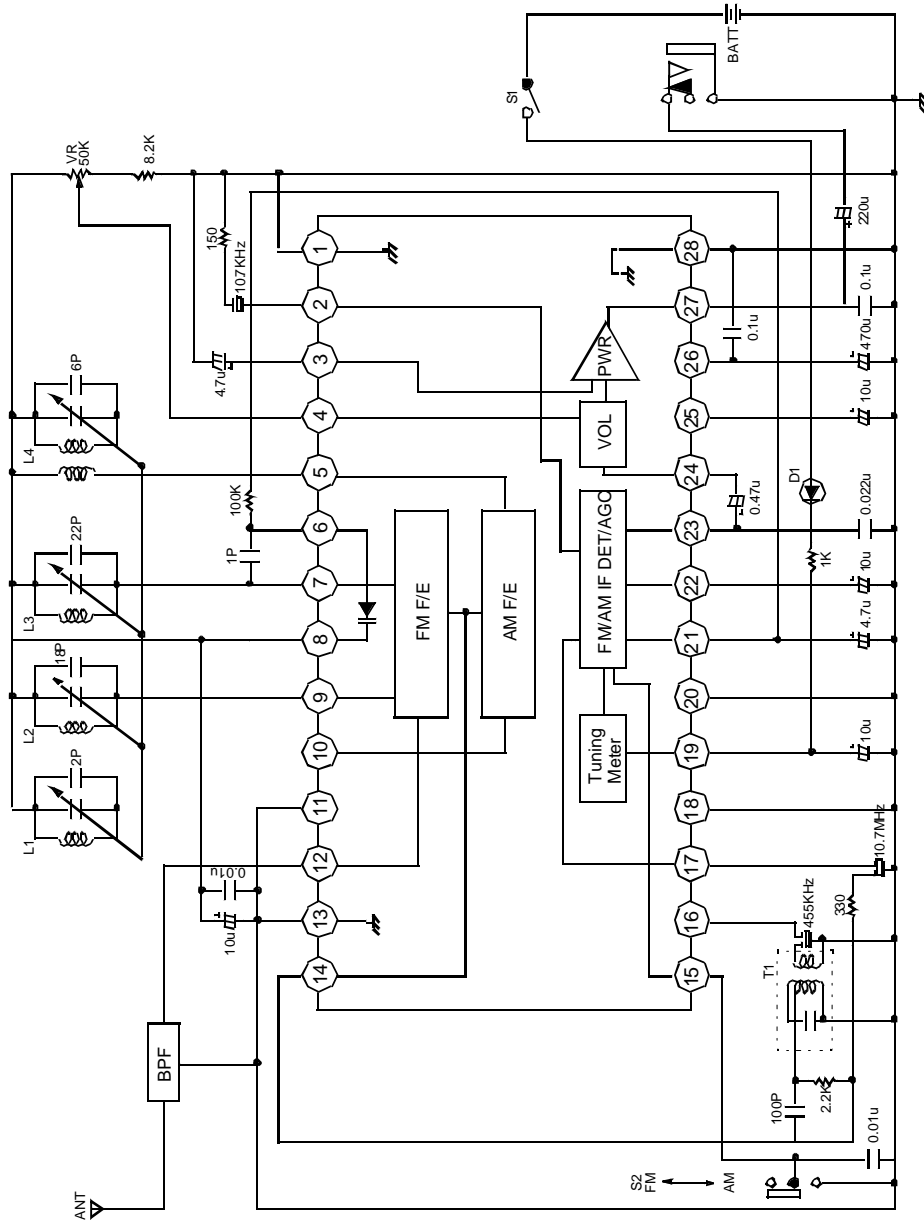

Fig. 3

