

3.5 INCH SPINDLE MOTOR DRIVER

The KA2822D is a monolithic integrated circuit, and suitable for the three-phase spindle motor driver of FDD system.

FEATURES

- 3-phase, full-wave, linear BLDC motor driver with 2 hall sensors
- Built-in soft switching drive circuit
- 300 or 360 RPM speed control
- Snubberless
- Built-in chip enable function
- Built-in digital speed control circuit
- Built-in current limit circuit
- Index sensorless
- Built-in TSD(Thermal Shutdown)
- Low saturation voltage
- Digital input : TTL,5V CMOS Compatible
- Built-in current-mode control circuit(I_{PEAK} : 1A)

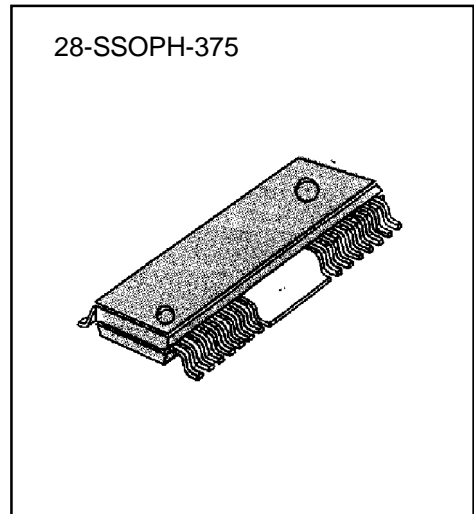

ORDERING INFORMATION

Device	Package	Operating Temperature
KA2822D	28-SSOPH-375	0 ~ 75 °C

BLOCK DIAGRAM

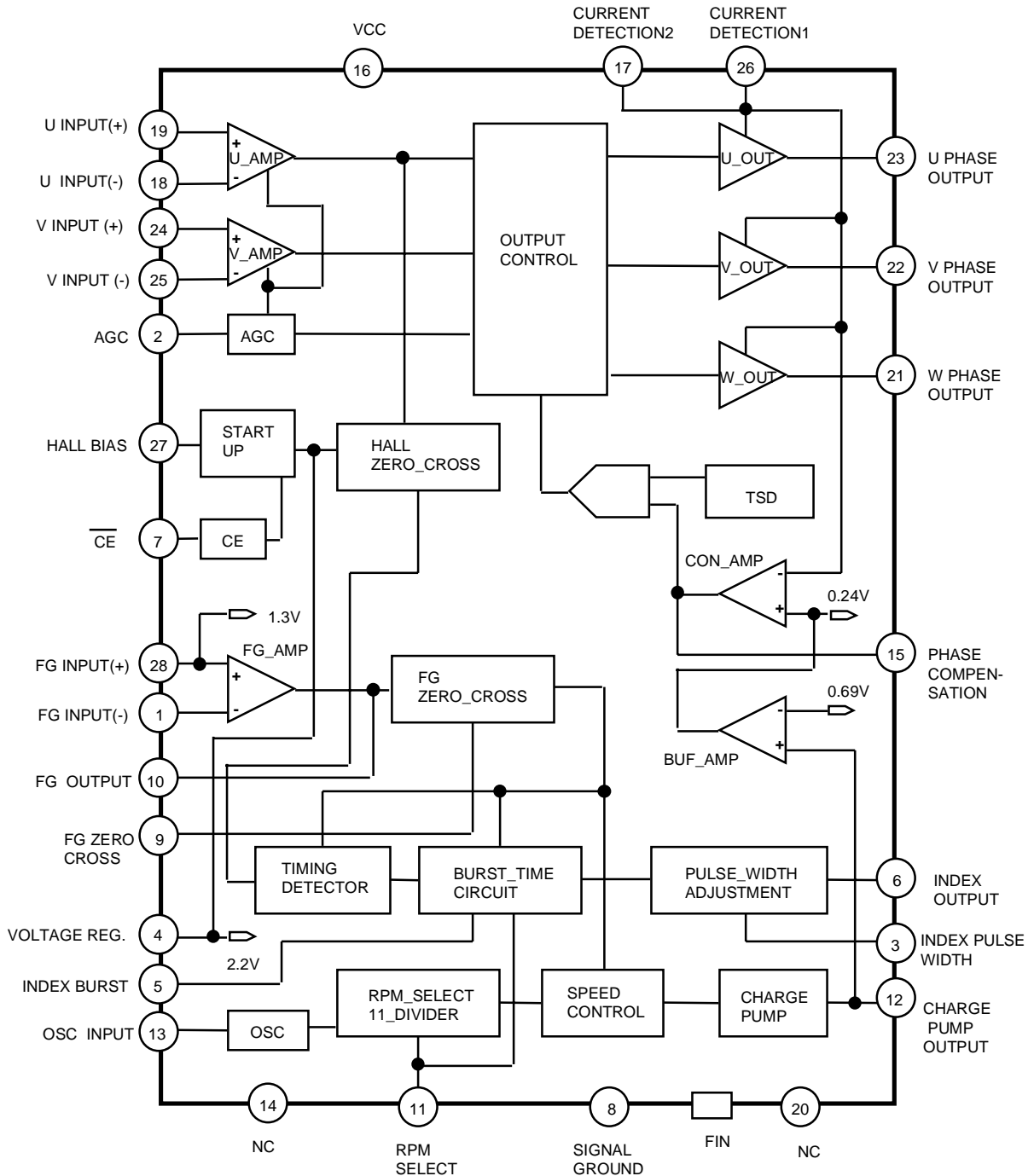

PIN CONFIGURATION

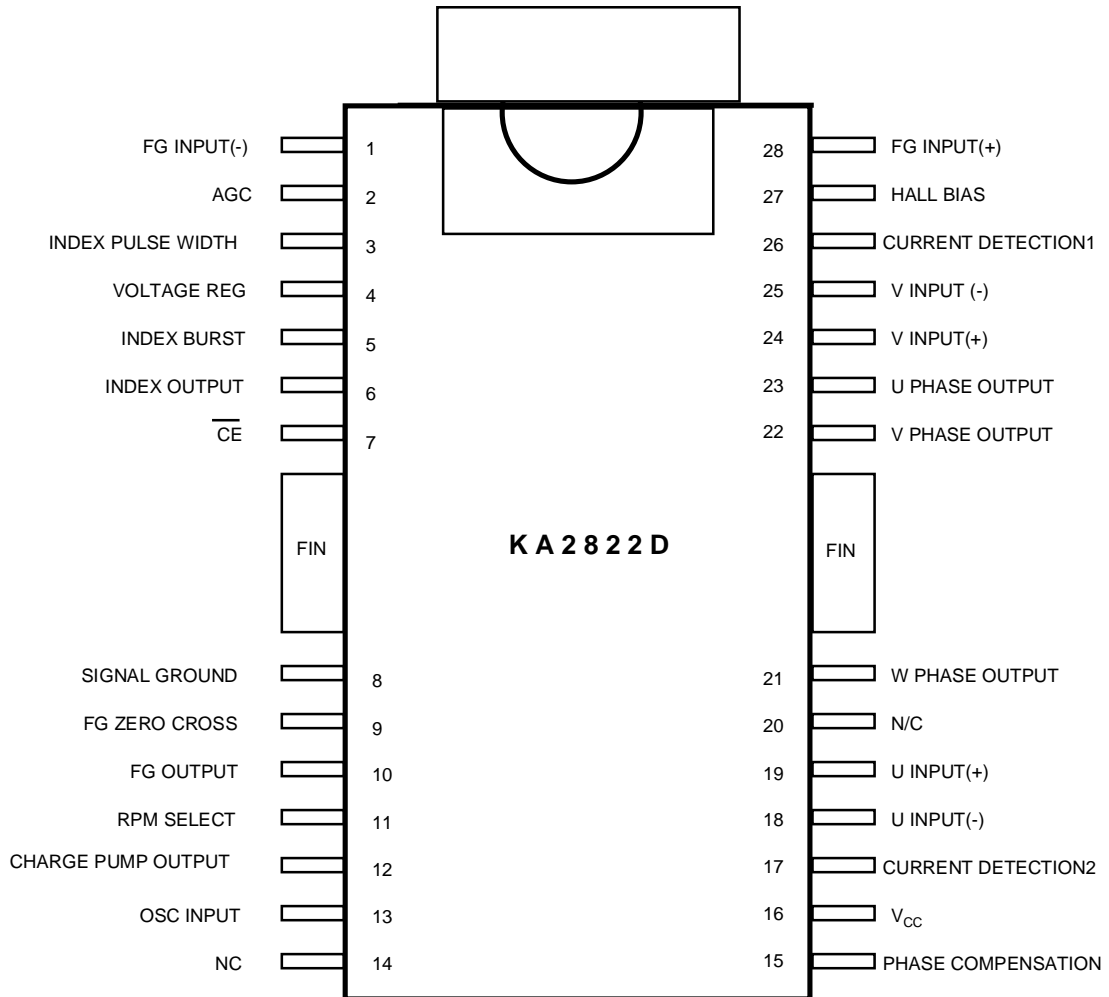

PIN DESCRIPTION

NO.	SYMBOL	I/O	DESCRIPTION
1	FG_INPUT	I	Negative Input Pin of FG Singal Amp.
2	AGC	I	Automatic Gain Control Input Pin
3	INDEX PULSE WIDTH	O	Index Pulse Width Detection(1.1V) Pin
4	VOLTAGE REGULATOR	O	Voltage (2.2V) Genrator Output Pin
5	INDEX BURST	O	Index Pulse Width Detection(1.4V) Pin
6	INDEX OUTPUT	O	Index Pulse Output Pin
7	\overline{CE}	I	Chip Enable (Active Low)
8	SIGNAL GROUND	-	Signal Ground
9	FG ZERO CROSS	O	FG Signal Zero Cross Detection Pin
10	FG OUTPUT	O	FG Signal Output Pin
11	RPM SELECT	I	RPM Selection Pin(L:300, H:360 rpm)
12	CHARGE PUMP OUTPUT	O	Charge Pump Output Pin
13	OSC INPUT	I	1MHz Oscillation Input Pin
14	NC	-	No Connection
15	PHASE COMPENSATION	I	Phase Compensation Cap. Connection Pin
16	V _{CC}	-	5V Power Supply Pin
17	CURRENT DETECTION 2	I	Over Current Detection Pin
18	U INPUT(-)	I	Negative Input Pin of U Phase Amp
19	U INPUT(+)	I	Positive Input Pin of U Phase Amp
20	NC	-	No Connection
21	W PHASE OUTPUT	O	W Phase Output Pin
22	V PHASE OUTPUT	O	V Phase Output Pin
23	U PHASE OUTPUT	O	U Phase Output Pin
24	U INPUT(+)	I	Positive Input Pin of V Phase Amp
25	V INPUT(-)	I	Negative Input Pin of V Phase Amp
26	CURRENT DETCETION 1	I	Over Current Detection Pin
27	HALL BIAS	I	Hall sensor Bias Input Pin
28	FG INPUT(+)	I	Positive Input Pin of FG Signal Amp
FIN	POWER GROUND	-	Power Ground

EQUIVALENT CIRCUITS

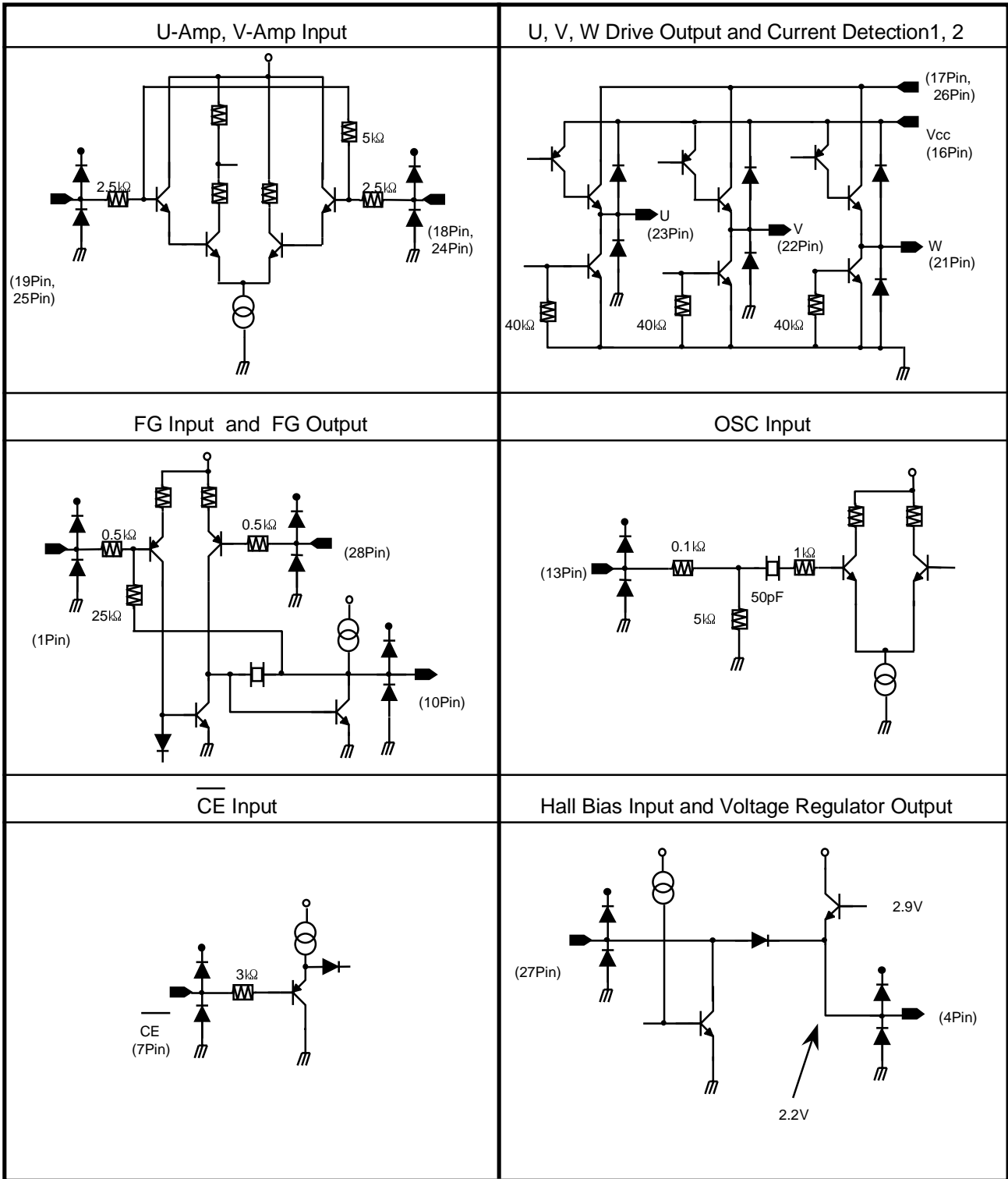

EQUIVALENT CIRCUITS(Continued)

<p style="text-align: center;">Index Pulse Width Detection Output</p>	<p style="text-align: center;">Phase Compensation and Current Detection1, 2 Pin</p>
<p style="text-align: center;">RPM Select Input</p>	<p style="text-align: center;">AGC Input</p>
<p style="text-align: center;">INDEX Output</p>	<p style="text-align: center;">INDEX BURST Output</p>

EQUIVALENT CIRCUITS(Continued)

FG ZERO CROSS Output

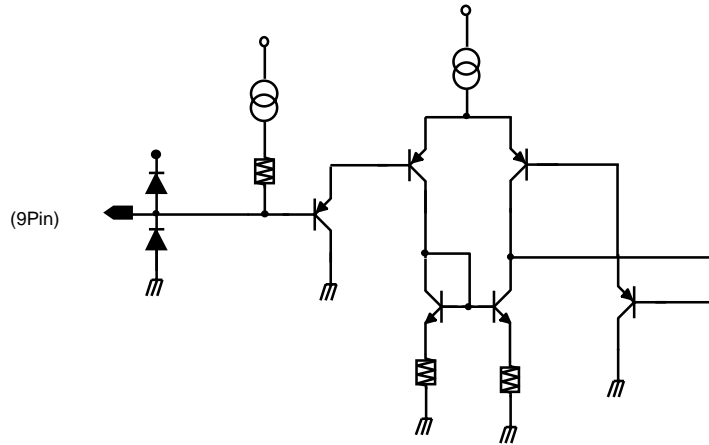

Charge Pump Output

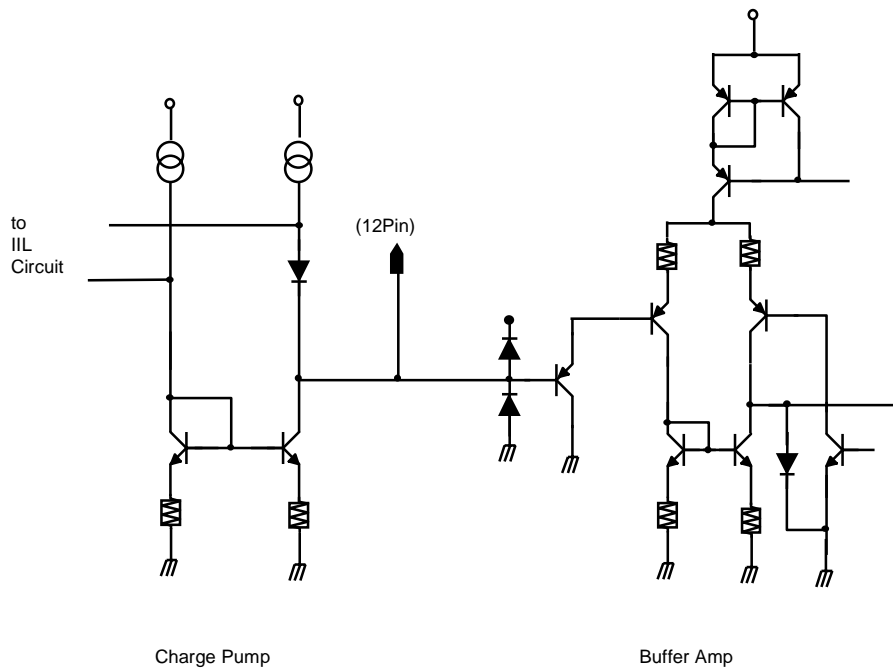

ABSOLUTE MAXIMUM RATING

Characteristics	Symbol	Value	Unit
Maximum Power Supply Voltage	V _{cc(max)}	7.0	V
Maximum Input Voltage	V _{in(max)}	0 ~ V _{cc}	V
Peak Output Current	I _{o(Peak)}	1	A
Normal Output Current	I _o	0.7	A
Power Dissipation	P _D	1.5	W
Operating Temperature	T _A	0 ~ +75	°C
Junction Temperature	T _J	150	°C
Storage Temperature	T _{STG}	-55 ~ +125	°C

RECOMMENDED OPERATING CONDITIONS

Characteristics	Symbol	Value			Unit
		Min	Typ	Max	
Power Supply Voltage	V _{cc}	4.25	5.0	6.5	V

TEMPERATURE CHARACTERISTIC

Characteristics	Symbol	Value			Unit
		Min	Typ	Max	
* Thermal Shutdown Temperature	TSD	125	150	-	°C

Note * : Reference value

ELECTRICAL CHARACTERISTICS

 $T_A = 25^\circ\text{C}, V_{CC} = 5\text{V}$

Characteristics	Symbol	Conditions	Value			Unit
			Min	Typ	Max	
Supply Current						
Supply Current1	I_{CCO}	$\overline{V_{CC}}=6.5\text{V}$ $\overline{CE}=H, RPM=L$	-	1.0	2.0	mA
Supply Current2	I_{CC}	$V_{CC}=6.5\text{V}, CE=L$	-	15	23	mA
Chip Enable						
Input Current	I_{CE}	$\overline{CE}=0 \sim 5\text{V}$	-	± 5	± 10	μA
Input Low Voltage	V_{CE1}	-	-	-	0.8	V
Input High Voltage	V_{CEH}	-	2.0	-	-	V
RPM Select						
Input Current	I_{RPM}	$\overline{CE}=0 \sim 5\text{V}$	-	± 5	± 10	μA
Input Low Voltage	V_{RPM1}	-	-	-	1.0	V
Input High Voltage	V_{RPMH}	-	3.5	-	-	V
Hall Amp						
* Input Resistance	R_{IN}	-		10	-	$k\Omega$
* Common Mode Input Voltage Range	V_{COM}	-	2.0	-	V_{CC}	V
* Differential Input Voltage Range	V_{DIF}	-	70	-	210	mVp-p
Start-up						
Hall Bias Voltage 1	V_{hb1}	$I_h=4\text{mA}, CE=L$	2.0	2.5	3.0	V
Hall Bias Voltage 2	V_{hb2}	$I_h=10\text{mA}, CE=L$	2.4	2.9	3.4	V
Reference Voltage	V_{ref}	$I_o=1\text{mA}, CE=L$	1.7	2.2	2.7	V
Bias Off Current	I_{hoff}	$V_h=7\text{V}, CE=H$	-	± 5	± 10	μA
Output Amp						
Leakage Current	I_{cer}	-	-	± 0.5	± 1	mA
Saturation Voltage 1	V_{sat1}	$I_o=0.35\text{A}$	-	1.0	1.2	V
Saturation Voltage 2	V_{sat2}	$I_o=0.7\text{A}$	-	1.3	1.8	V
Buffer & Control Amp						
Voltage Gain 1	G_{ct1}	-	-	-11	-	dB
Reference Voltage 1	V_{ref1}	Current Limiter Voltage	0.215	0.24	0.265	V
Reference Voltage 2	V_{ref2}	Control Begin Voltage	-	0.69	-	V

ELECTRICAL CHARACTERISTICS (Continued)

 $T_A = 25^\circ\text{C}, V_{CC} = 5\text{V}$

Characteristics	Symbol	Conditions	Value			Unit
			Min	Typ	Max	
Charge Pump						
Charge Current	I_{CP-}	RPM=L	-15	-20	-25	μA
discharge Current	I_{CP+}	RPM=L	15	20	25	μA
* Current Ratio	I_R	I_{CP+}/I_{CP-}	0.9	1.0	1.1	-
Off Current	I_{OFF}	$V_{CP}=0.63\text{V}$	-	-	± 50	nA
* Clamp Voltage	V_{CLP}	-	-	1.3	1.5	V
FG Amp						
* Output DC Voltage	V_{FG}	-	1.0	1.3	1.6	V
Voltage Gain 2	G_{FG}	-	24	34	44	dB
* Input Voltage Range	V_{IN}	-	2.0	-	20	mVp-p
* Noise Margin 1	N_D	Differential Noise	-	-	0.5	mVp-p
* Noise Margin 2	N_C	Common Mode Noise	-	-	0.5	Vp-p
Speed Control						
* Count Range 1	N1	RPM=L	-	1666.5	-	-
* Count Range 2	N2	RPM=H	-	1388.5	-	-
Operating Freq.	Fd	-	-	1.0	1.1	MHz
Burst Adjustment						
Input Current	Ibi	-	-	± 1	± 2	μA
Threshold Voltage 1	Vth1	RPM=L	1.2	1.45	1.7	V
Threshold Voltage 2	Vth2	RPM=H	1.05	1.3	1.55	V
pulse Width Adjustment						
Ct2 Charge Current	Ict2	-	-19	-25	-36	μA
Threshold Voltage 3	Vth3	-	0.9	1.1	1.3	V
Index Output						
* Output Leakage Current	Ioh	-	-	± 1	± 2	μA
Output Low Voltage	Vo1	$I_o=2\text{mA}$	-	0.2	0.4	V

Note * : Reference value

APPLICATION INFORMATION

1. Chip Enable

This function turns ON or OFF all blocks by Low or High signal.

2. U, V and W Phase Output Amp

This part drives the output as making U, V and W current waveform having 120 ° phase difference with using the current ratio of each Amp output after giving the signal occurred by 2 Hall sensors to U Amp and V Amp.

It gets U, V and W phase output as operating output power TR sequentially by the relative current comparison.

3. Speed Control Part

This function compares the real motor rotation frequency with the 300 or 360Hz pulse divided from 1MHz clock pulse for removing an speed error when motor is ON and speed error is detected by PLL.

The speed error sent to charge pump part which repeats charge and discharge controls the output current of the output amp to keep a stable rotation.

GRAPHS

Fig. 1 Vcc vs. Icc

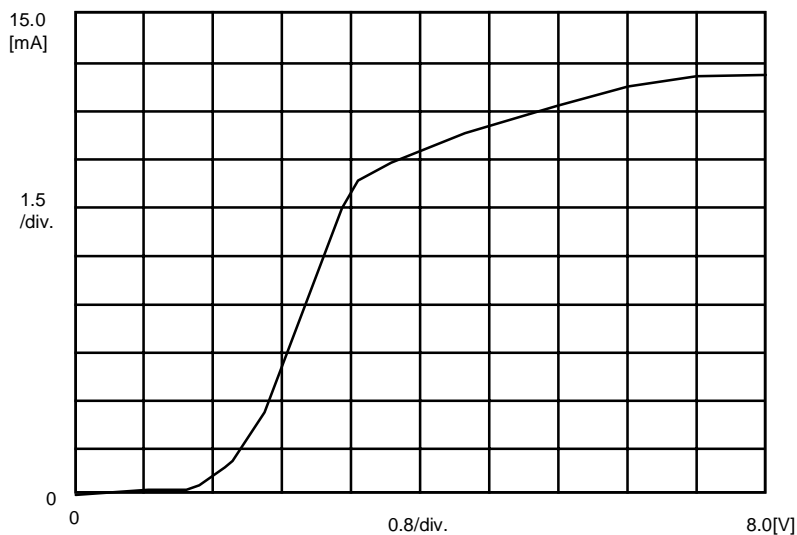

Fig. 2. Vcc vs. Vref(Pin4)

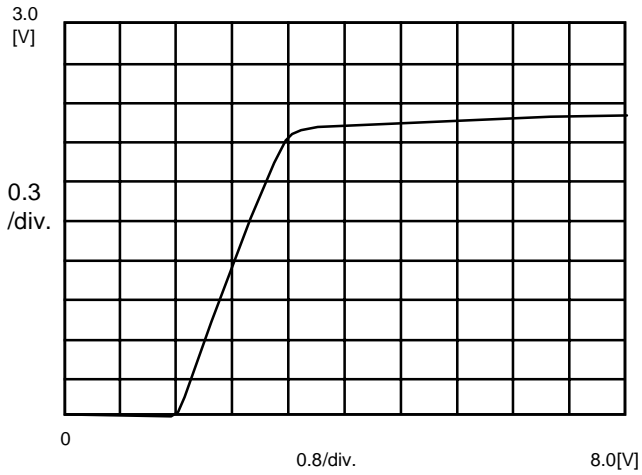

Fig. 3. Vcc vs. INDEX Pulse Width

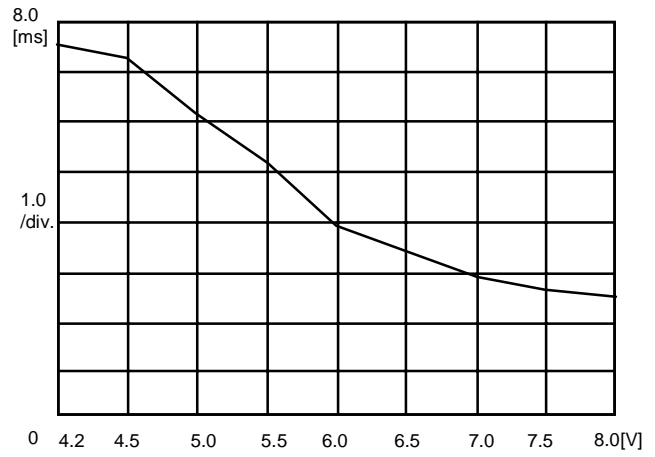
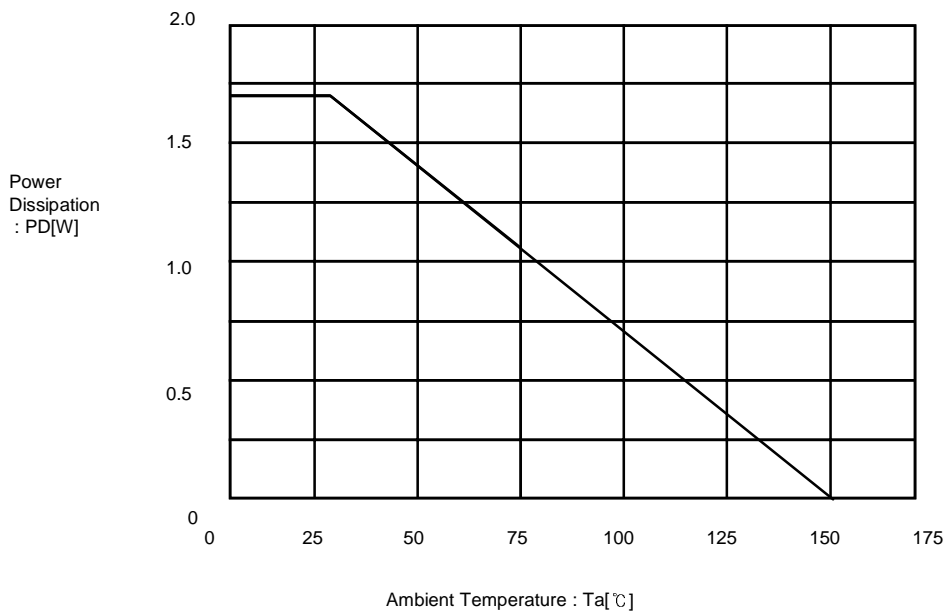
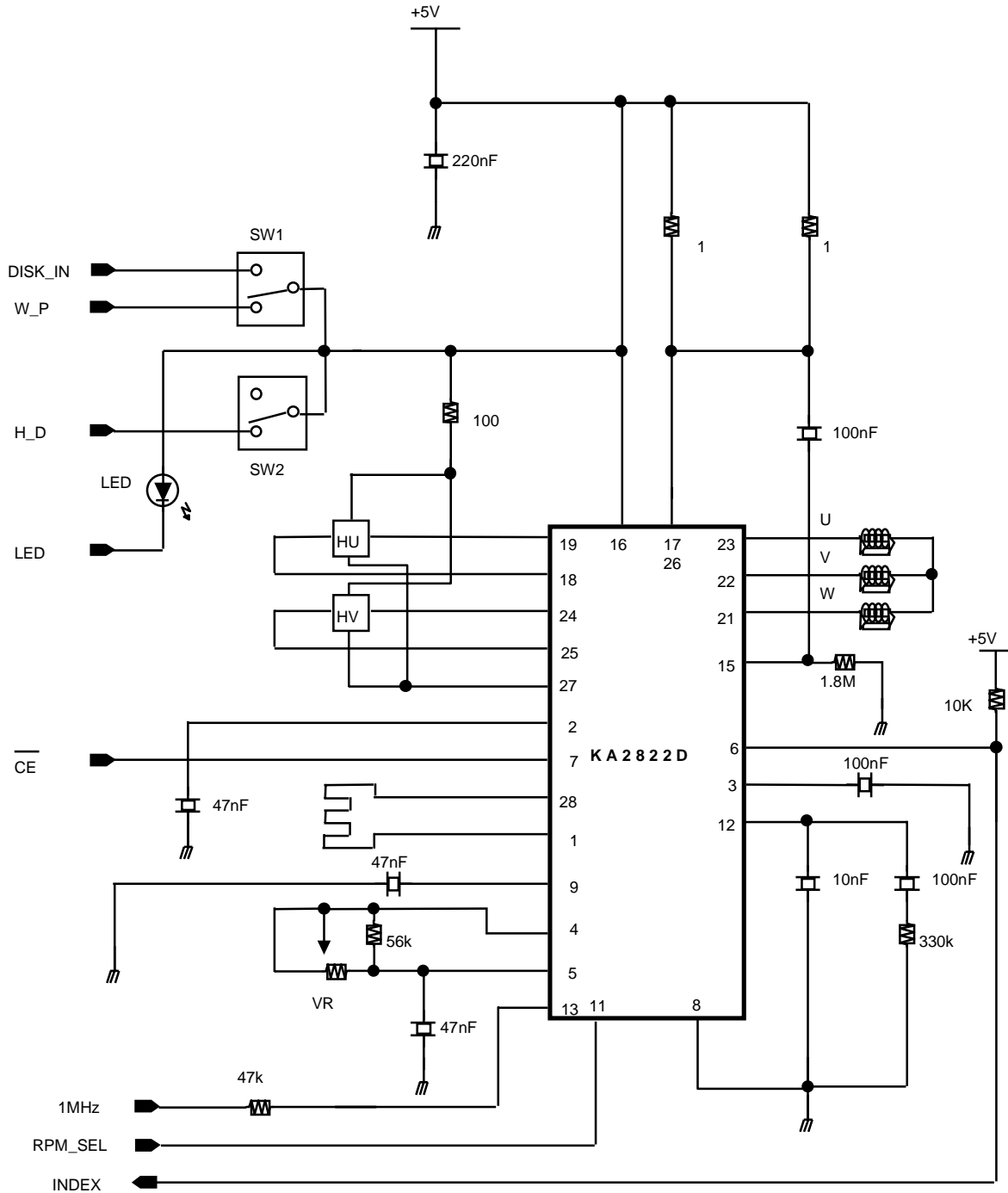

Fig. 4. Power Dissipation Curve



Power dissipation decreases in the rate of 13.6mW/°C when mounted on 50mm×50mm×1mm PCB (Phenolic resin material) and used above Ta=25°C.

APPLICATION CIRCUIT



PACKAGE DIMENSIONS (Unit : mm)

28-SSOPH-375

