

GENERAL DESCRIPTION

The KA7305 is a monolithic integrated circuit for B/W CCD camera 1 chip signal processor. It contains functional block from CDS to video driver and 2 comparators for EE mode. Also, it performs a low power onsumption and a small dimension of set implementation by decreasing external parts as a 1 chip.

FEATURES

- * 5 Steps sample & hold.
- * 4 dB ~ 32 dB AGC gain control.
- * Built in 2 comparators for EE mode control.
- * EE mode WND / BLK selectable.
- * Gamma $\gamma = 0.45$ / Linear output separation.
- * Built in OP-AMP for AGC loop.
- * 3 Mode set-up control.
- * 2 Mode white / clip control.
- * 75 Ohm video driver & sag compensation.

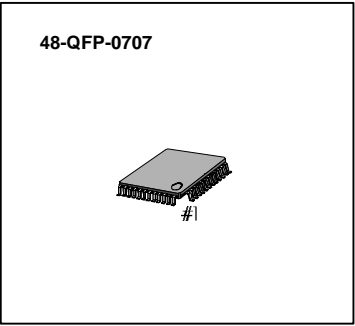

ORDERING INFORMATION

Device	Package	Operating Temperature
KA7305	48-QFP-0707	-20°C ~ +75°C

BLOCK DIAGRAM

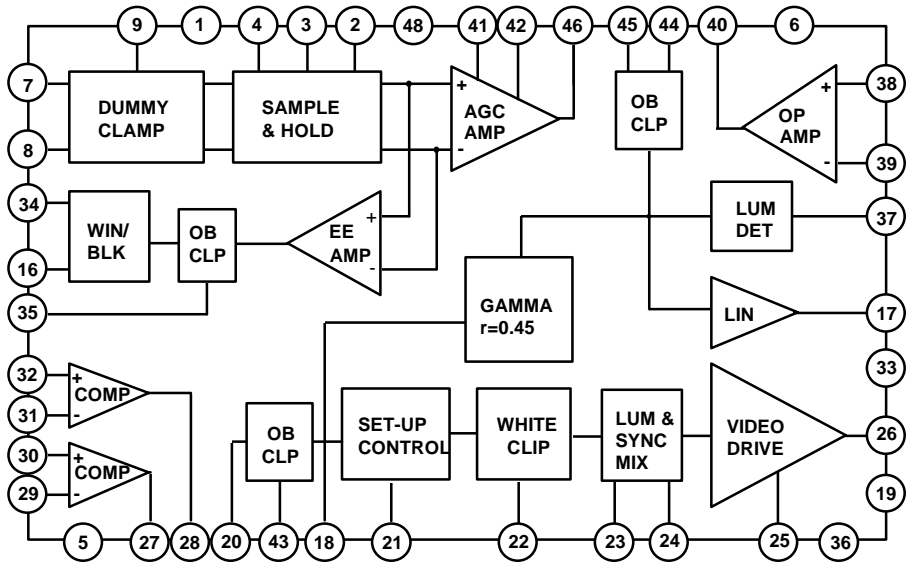

PIN CONFIGURATION

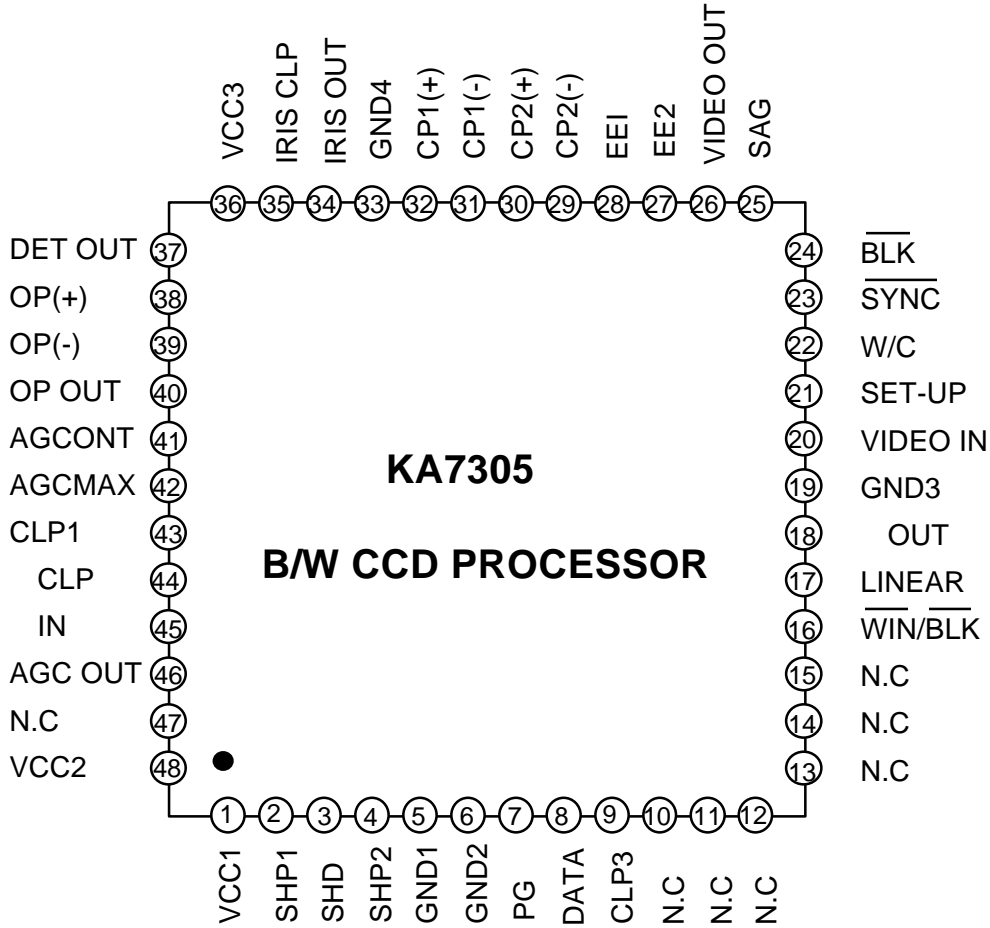

PIN DESCRIPTION

No	Symbol	I/O	Description	Remark
1	VCC1	-	Power supply	
2	SHP1	I	Precharge sample & hold pulse	Active high
3	SHD	I	Data sample & hold pulse	Active high
4	SHP2	I	Precharge sample & hold pulse	Active high
5	GND1	-	Ground	
6	GND2	-	Ground	
7	PG	I	CCD signal input	
8	DATA	I	CCD signal input	
9	CLP3	I	Dummy clamp pulse	Active high
10	N.C	-	No connection	
11	N.C	-	No connection	
12	N.C	-	No connection	
13	N.C	-	No connection	
14	N.C	-	No connection	
15	N.C	-	No connection	
16	WIN/BLK	I	Window/Blank pulse	Active high
17	LINEAR	O	Linear out	
18	Y OUT	O	Gamma out	
19	GND3	-	Ground	
20	VIDEO IN	I	Video driver input signal	
21	SET-UP	I	Set - up level control	
22	W/C	I	White - clip level control	
23	SYNC	I	Composite sync pulse	
24	BLK	I	Composite blank pulse	
25	SAG	I	Sag compensation	
26	VIDEO OUT	O	Composite video signal output	
27	EE2	O	EE more comparator output 2	
28	EE1	O	EE more comparator output 1	
29	CP2(-)	I	EE more comparator2 - input	
30	CP2(+)	I	EE more comparator2 + input	
31	CP1(-)	I	EE more comparator1 - input	
32	CP1(+)	I	EE more comparator1 + input	
33	GND4	-	Ground	
34	IRIS OUT	O	IRIS detect output	
35	IRIS CLP	-	IRIS clamp	
36	VCC3	-	Power supply	
37	DET OUT	O	AGC detect output	
38	OP(+)	I	AGC OP AMP input (+)	
39	OP(-)	I	AGC OP AMP input (-)	
40	OP OUT	O	AGC OP AMP output	
41	AGCONT	I	AGC gain control	
42	AGCMAX	I	AGC maximum gain control	
43	CLP1	I	Optical black level clamp pulse	Active high
44	Y CLP	-	Gamma clamp	
45	Y IN	I	Gamma input	
46	AGC OUT	O	AGC output signal	
47	N.C	-	No connection	
48	VCC2	-	Power supply	

ABSOLUTE MAXIMUM RATINGS (Ta = 25°C)

Characteristics	Symbol	Value	Unit
Power Supply Voltage	VCC	7	V
Power Dissipation	Pd	500	mW
Operating Temperature	Topr	-20 ~ +75	°C
Storage Temperature	Tstg	-65 ~ +150	°C

ELECTRICAL CHARACTERISTICS (VCC = 5V, Ta = 25°C)

Characteristics	Symbol	Test Condition	Min	Typ	Max	Unit
Operating Voltage	VCC	-	4.75	5.00	5.25	V
Supply Current	ICC	-	30	45	60	mA
AGC Max Min Gain	G46a	AGC Max = 4V, Data In = 100mA AGC Cont = 1.5V	-	18	20	dB
AGC Cont Min Gain	G46b	AGC Cont = 5V, Data In = 500mV	-	4	6	dB
AGC Cont Max Gain	G46c	AGC Max = 0V, Data In = 30mV AGC Cont = 1.5V	30	32	-	dB
AGC Cont 10dB	G46d	AGC Max = 0V, Data In = 320mV AGC Cont = 3.55v	8	10	12	dB
AGC Out D.C	V46		2.25	2.55	2.85	V
Detect Out D.C	V37		1.8	2.0	2.2	V
Iris Out D.C	V34		1.1	1.3	1.5	V
Iris Amp Gain	G34		8	10	12	dB
Linear Amp Gain	G17		1.6	2.6	3.6	dB
Gamma Output Level	V18	γ In = 500mV _{P-P}	510	610	710	mV _{P-P}

ELECTRICAL CHARACTERISTICS (VCC = 5V, Ta = 25°C)

Characteristics	Symbol	Test Condition	Min	Typ	Max	Unit
Video Amp Gain	G26		5.7	6.0	6.3	dB
Sync Level	Vsync		26.3	286	309	mV _{P-P}
Set - Up Level 1	Vset1	S/U Cont = 0V	-15	0	+15	mV _{P-P}
Set - Up Level 2	Vset2	S/U Cont = 5V	0	20	40	mV _{P-P}
Set - Up Level 3	Vset3	S/U Cont = 1.75V	-	-25	-3	mV _{P-P}
Set - Up Level 4	Vset4	S/U Cont = 3.3V	80	130	-	mV _{P-P}
White - Clip Level 1	Vwe1	S/U Cont = 0V	780	820	860	mV _{P-P}
White - Clip Level 2	Vwe2	S/U Cont = 2V	-	300	600	mV _{P-P}
White - Clip Level 3	Vwe3	S/U Cont = 5V	1000	1300	-	mV _{P-P}
OP - Amp Dynamic Range	Dop		3.3	-	-	V _{P-P}
EE Comparator & Level	Vch	Vin (+) = 2.6V, Vin (-) = 2.5V	4.5	-	-	V
EE Comparator & Level	Vcl	Vin (+) = 2.5V, Vin (-) = 2.6V	-	-	1.2	V

TEMPERATURE CHARACTERISTICS (VCC = 5V, Ta = -20°C ~ +75°C)

Characteristics	Symbol	Test Condition	Unit
AGC out D.C	V46	±5%	V
Detect out D.C	V37	±5%	V
EE AMP out D.C	V34	±5%	V
γ AMP out	V18	±5%	mV _{P-P}
Sync level	Vsy	±5%	mV _{P-P}

ELECTRICAL CHARACTERISTIC CURVE

AGC CONTROL vs AMP GAIN

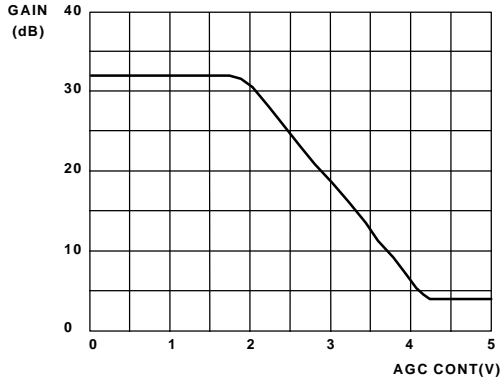

AGC MAX vs AMP GAIN

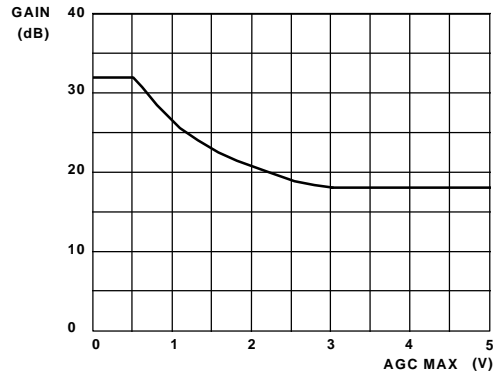

S/U CONT vs S/U LEVEL

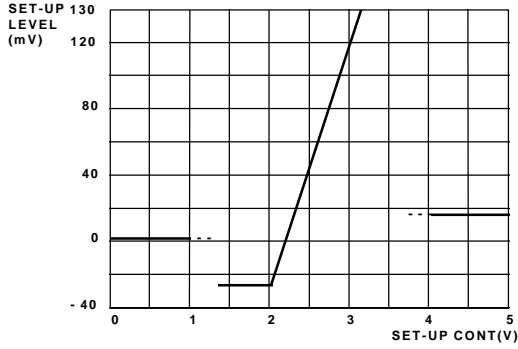

W/C CONT vs W/C LEVEL

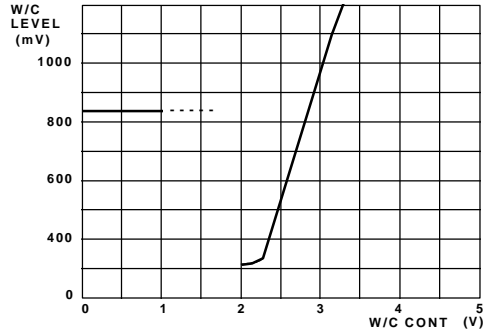

GAMMA INPUT vs OUTPUT

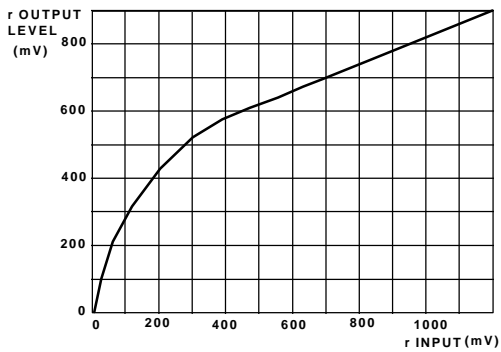

TEST INPUT/OUTPUT SIGNAL WAVEFORM

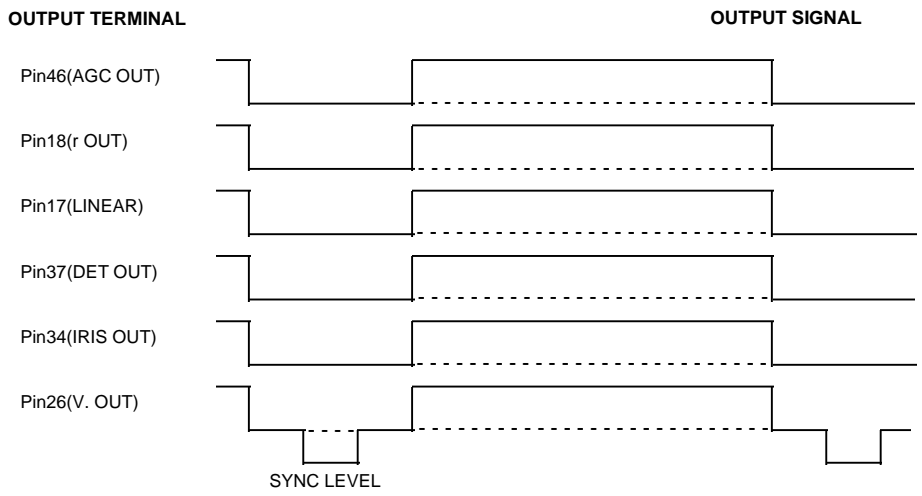
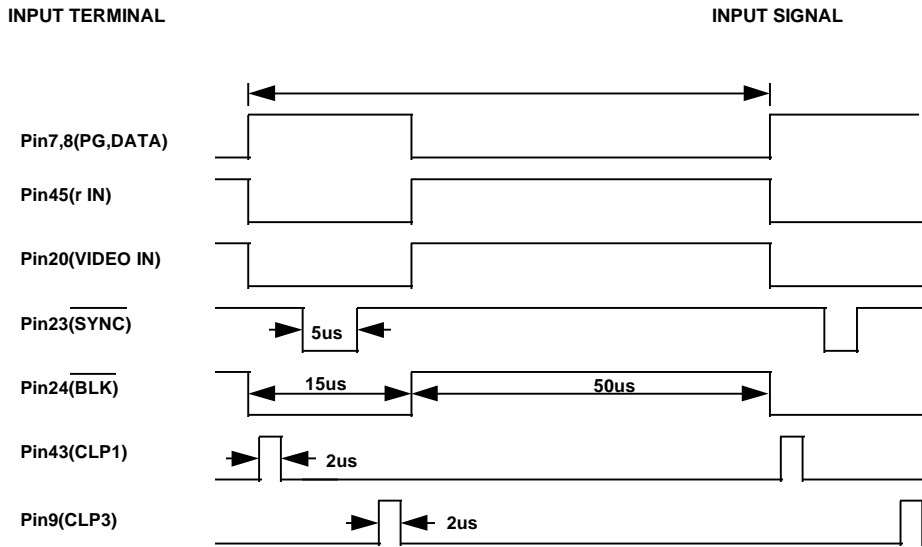

TEST CIRCUIT

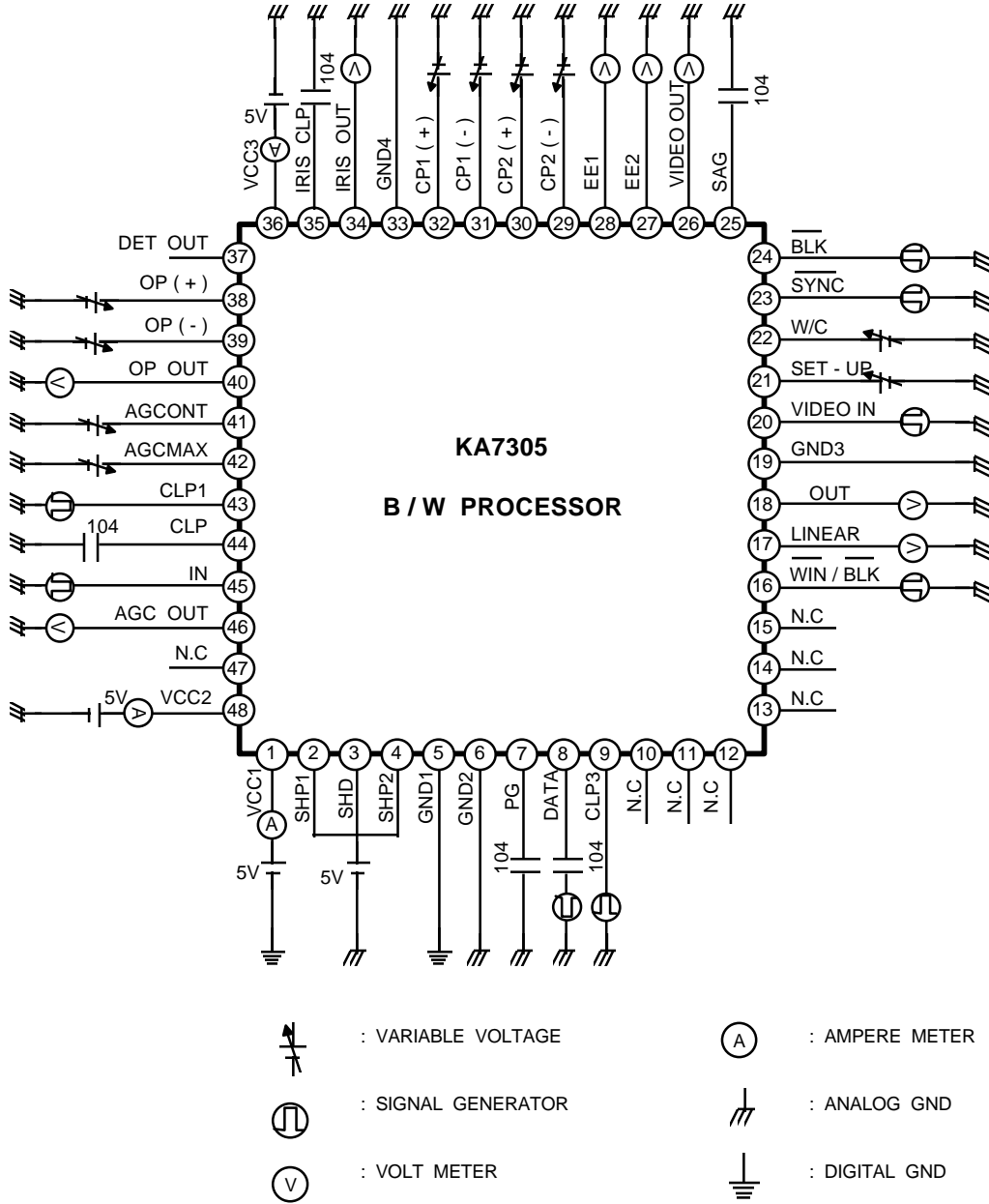

APPLICATION CIRCUIT

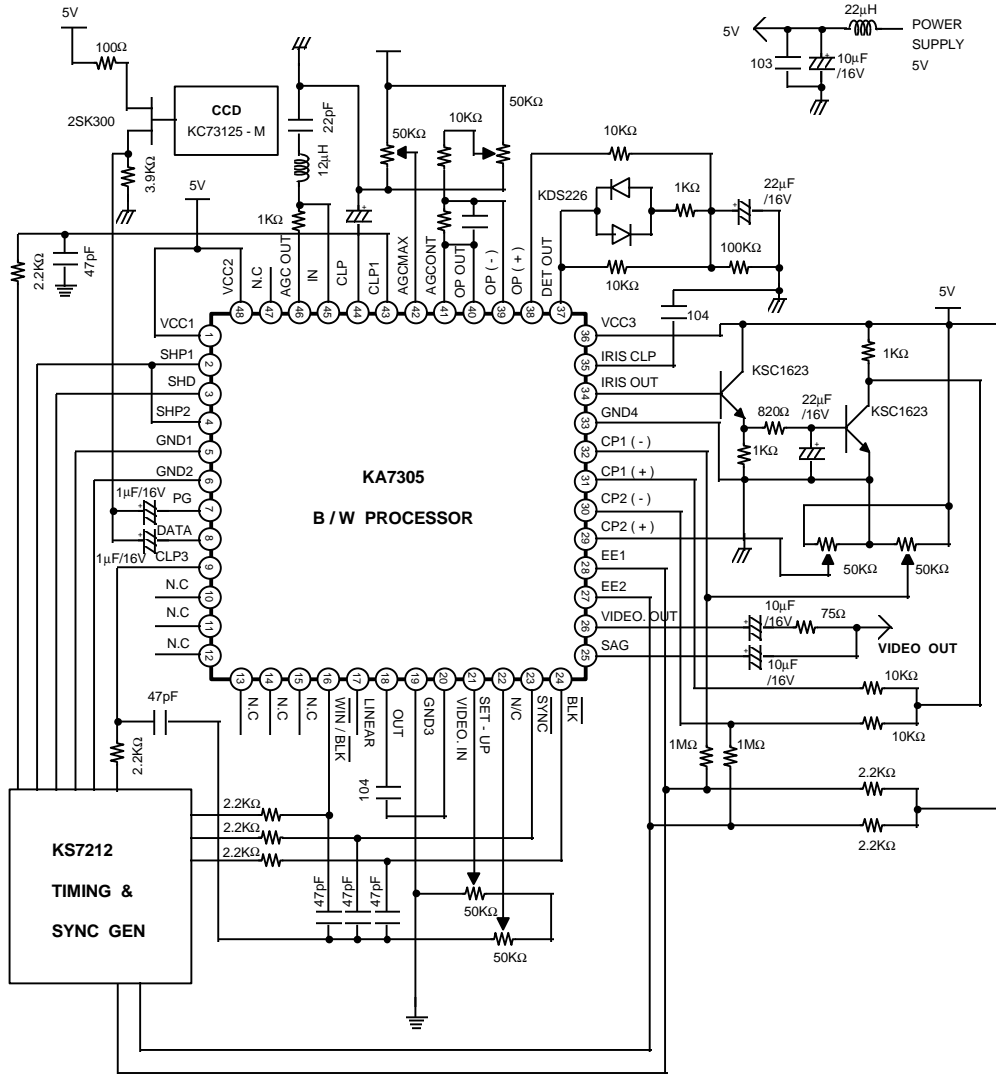

PACKAGE DIMENSION

48-QFP-0707

Unit : mm

