

1 PRODUCT OVERVIEW

Overview

The KD16902 Virtual Surround Processor enables an average customer to enjoy the surround effect of the Dolby Digital's (formally known as Dolby AC-3) 5.1 channel audio without the cost of implementing six speaker system. The chip implements Virtual Surround function, based on QSurround™ algorithm licensed from QSound Labs, Inc. The main part of the function converts the 5.1 channel output of Dolby Digital into 2 channel output without loss of the surround effect. Furthermore, the KD16902 provides an additional mode which produce the output with 3 to 5.1 channels. Therefore, the customer can enjoy the surround effect regardless of number of speakers using the KD16902.

The KD16902 has an extra pin designated for stereo output. The pin can be used for connection to VCR audio input. The Dolby Digital output is converted into two channel audio for this pin. This is an attractive feature because a DVDP's output can be recorded into VCR tape with the surround effect.

In addition to the Virtual Surround function, the KD16902 provides bass redirection function. The bass redirection function prevents small satellite speakers from reproducing deep bass signals which can be distorted. This feature enables the customer to implement Dolby Digital system without using expensive full range speakers for all 5.1 channels.

The KD16902 has additional flexibility of executing user defined function. The user written codes can be downloaded from the host and executed as an additional function.

Key Features

- Virtual Surround for systems with less than 6 speakers
- Bass Redirection
- Downmix
- User Defined Function
- 16 bit fixed point DSP core (SSP1605)
- Internal data RAM bank0 (256-word: dedicated; Three 256-word: Data/Program)
- Internal data RAM bank1 (256-word: dedicated; Three 256-word: Data/Program)
- 4K-word internal program ROM
- Default master clock: 33.8 MHz through built-in doubler using 16.934 MHz crystal when CKSEL=1
- CKI is external master clock when CKSEL=0
- 5.1 Channel Serial Audio Interface
- 32/44.1/48 KHz sampling frequency
- Serial Host Interface
- 64-pin QFP package
- 5 volt single power
- 0.6-μm double metal CMOS technology (CSP4HS)

Ordering Information

Table 1. Ordering Information

Device	Package	Temperature Range
KD16902	64 QFP	0°C - 70°C

Applications

- DVDP
- DVD-ROM
- Hi-Fi Audio Products

Typical Application

Figure 1. Typical Application of the KD16902 Virtual Surround Processor

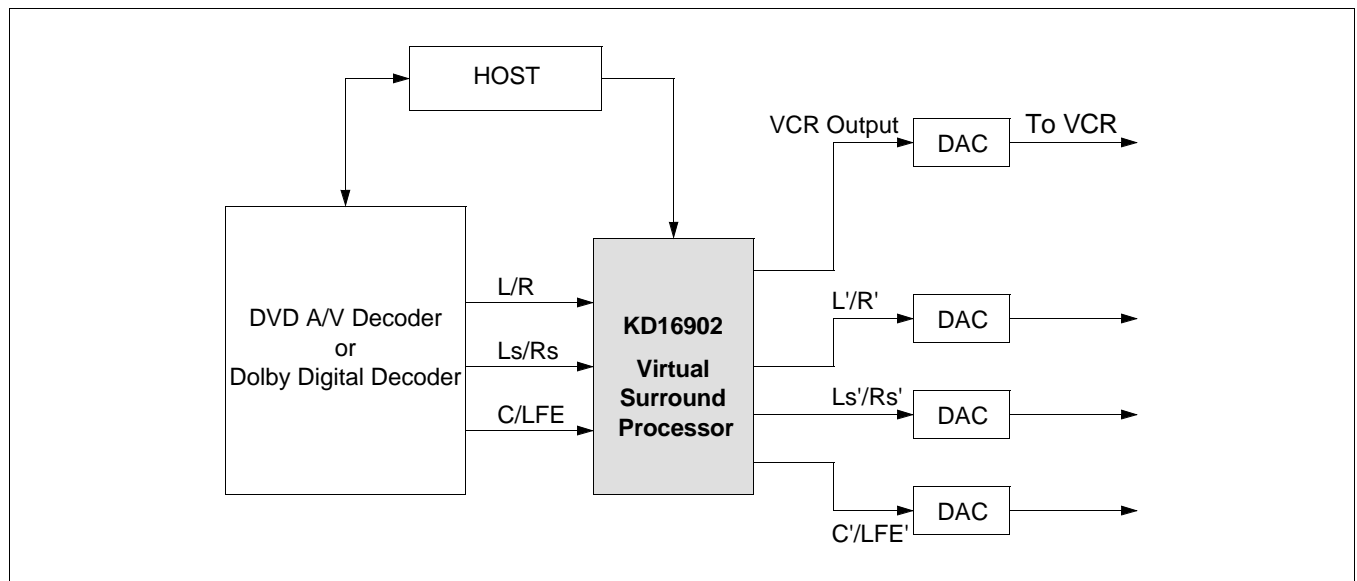

Block Diagram

Figure 2. Block diagram

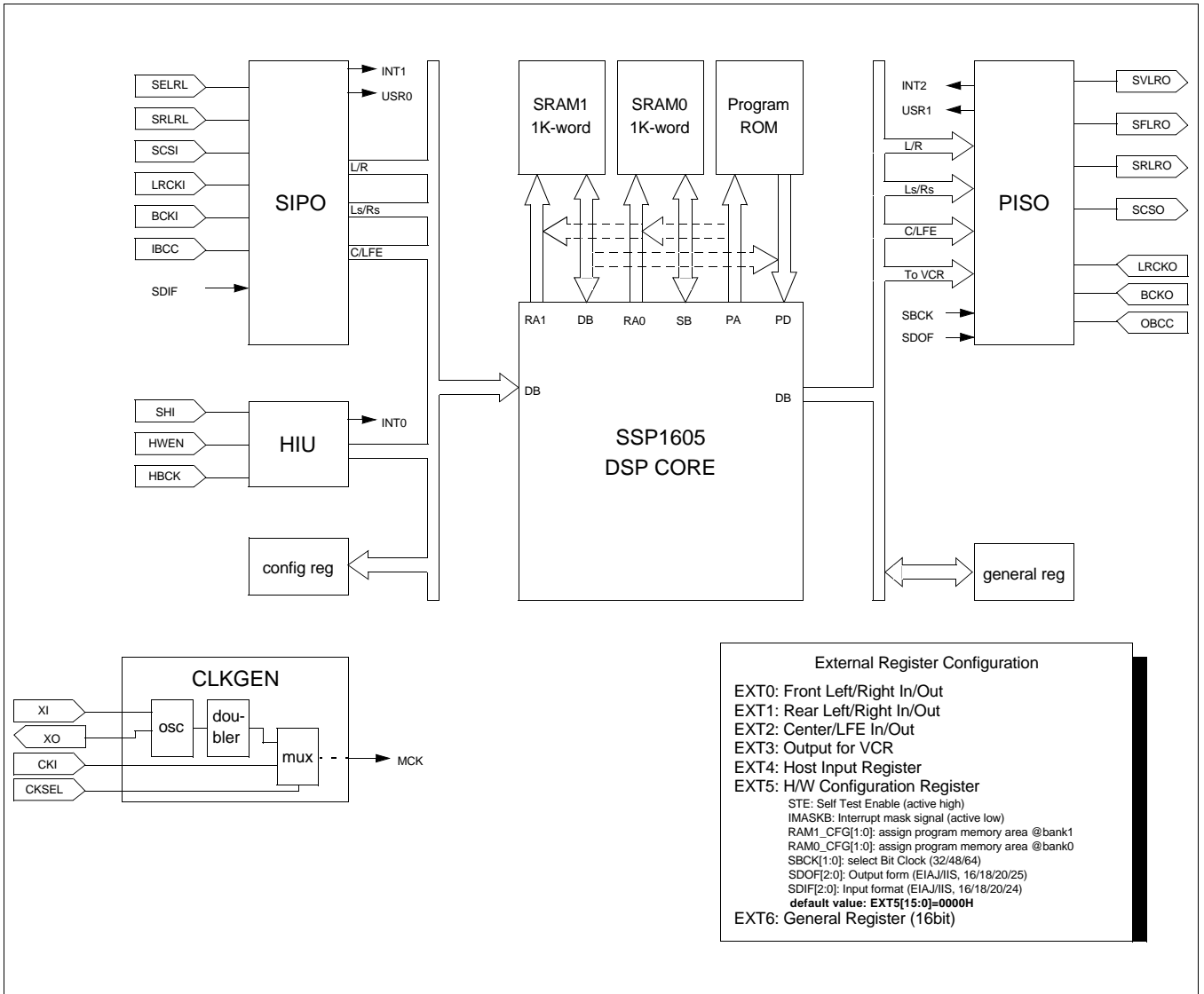

Pin Assignment

Figure 3. Pin Assignment (64 QFP)

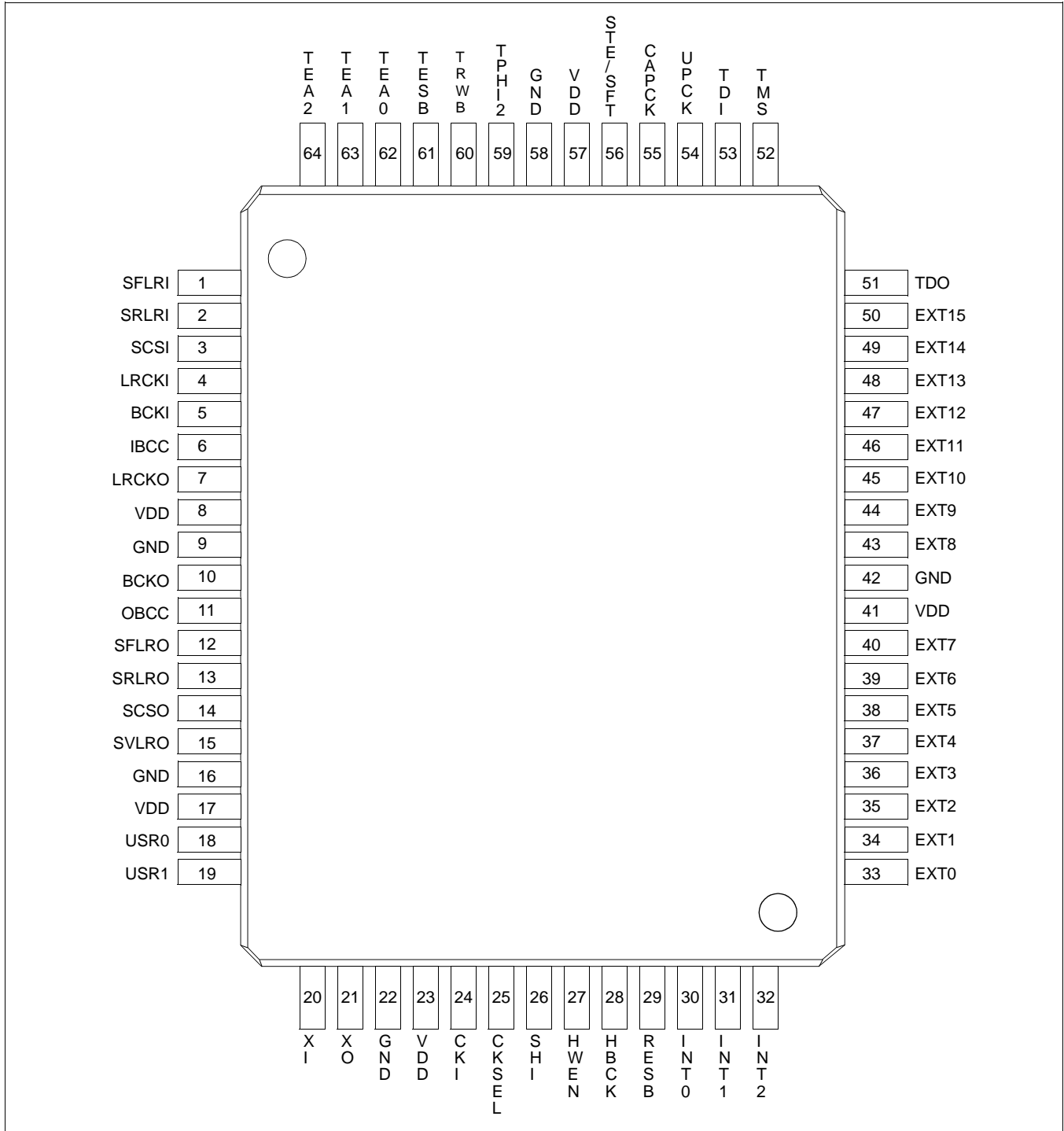

Pin Descriptions

Table 2. KD16902 Pin Descriptions (Type; pd=Pull-down, pu=Pull-up)

Pin Name	Number	I/O	Type	Pin Description
VDD	8,17,23,41,57	.	-	Power supply pins; 5.0 volt
GND	9,16,22,42,58	.	-	Ground pins
SFLRI	1	I	-	Serial digital audio signal input, Front Left/Right input
SRLRI	2	I	-	Serial digital audio signal input, Rear Left/Right input
SCSI	3	I	-	Serial digital audio signal input, Center/Subwoofer input
LRCKI	4	I	-	L/R word Clock Input of serial digital audio in
BCKI	5	I	-	Bit Clock Input of serial digital audio in
IBCC	6	I	pd	Input Bit Clock Control(0:normal, 1:reverse)
LRCKO	7	I	-	L/R word Clock Input of serial digital audio out
BCKO	10	I	-	Bit Clock Input of serial digital audio out
OBCC	11	I	pd	Output Bit Clock Control(0:normal, 1:reverse)
SFLRO	12	O		Serial digital audio signal output, Front Left/Right output
SRLRO	13	O		Serial digital audio signal output, Rear Left/Right output
SCSO	14	O		Serial digital audio signal output, Center/Subwoofer output
SVLRO	15	O		Serial digital audio signal output, Left/Right output to VCR
USR0~1	18~19	O		Test pin
XI	20	I	-	Crystal input when CKSEL=1; 16.934 MHz (dedicated)
XO	21	O	-	Crystal output
CKI	24	I	-	External Clock Input
CKSEL	25	I	pd	Select crystal/external; 1: crystal input, 0: external clock input
SHI	26	I	-	Serial Host Input
HWEN	27	I	-	Host Write Enable; Low active
HBCK	28	I	-	Host Bit Clock of serial data in
RESB	29	I	pu	Asynchronous Reset. Effective when CKI is rising
INT0~1	30~32	O		Test pin
EXT0~15	33~40,43~50	I/O	pu	Test pin; External bus data
TDO	51	O		Test pins; Test Output@TMS=1 / Nand-tree output@TMS=0
TMS	52	I	pd	Test pin; Test Mode Select (1: test mode, 0: normal mode)
TDI	53	I	pd	Test pins; Test Input@TMS=1 / Nand-tree input@TMS=0

Table 2. KD16902 Pin Descriptions (Type; pd=Pull-down, pu=Pull-up)

Pin Name	Number	I/O	Type	Pin Description
UPCK	54	I	pd	Test pin; Update clock
CAPCK	55	I	pd	Test pin; capture clock
STE/SFT	56	I	pd	Self-Test Enable(active high); Shift enable signal@test mode
TPHI2	59	I	pd	Test pin
TRWB	60	I	pd	Test pin; External bus read/write enable signal
TESB	61	I	pd	Test pin; External bus strobe signal
TEA0~2	62~64	I	pd	Test pin; External bus address

2 HARDWARE DESCRIPTION

DSP Core

- Up to 33 MIPS 16bit fixed point DSP core (SSP1605)
- 16 x 16 multiplier with 32 bit product
- 32 bit ALU / accumulator
- 0.6-μm double metal CMOS technology (CSP4HS)

Memory

- 4 K-word internal program ROM
- Maximum 2K-word internal data RAM

Figure 4. Memory Configuration

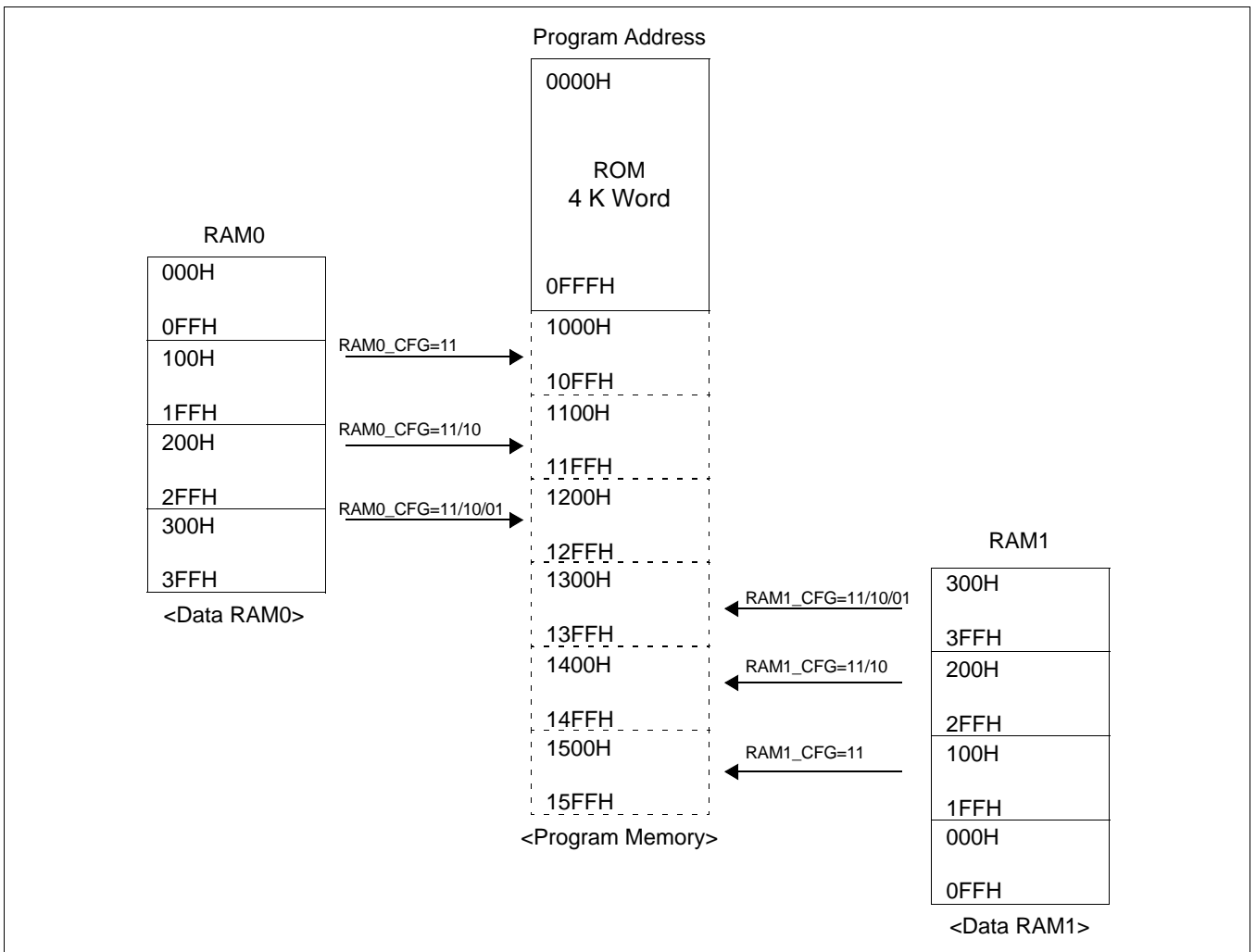

Hardware configuration

External register configuration

- EXT0: Front Left/Right channel In/Out port
- EXT1: Rear Left/Right channel In/Out port
- EXT2: Center/LFE channel In/Out port
- EXT3: VCR output port
- EXT4: Host Input Register
- EXT5: H/W Configuration Register (default value: EXT5[15:0]=0000H)
- EXT6: General Register (16 bit register read or write available)

Table 3. EXT5 Assignment

Bit	Assignment	Description
15:14	-	reserved
13	STE	Self test enable signal (active high); status input (read only) If STE=1, execute built-in self test program after RESB is released. STE=0, run normal processing.
12	IMASKB	Interrupt mask signal (active low, default value = low) If IMASKB=0, ignore any interrupt request. IMASKB=1, serve interrupt request
11:10	RAM1_CFG[1:0]	Assign program memory area on RAM bank1 00: Program memory= None 01: 300~3FF Hex -> Program memory= 1300~13FF Hex 10: 200~3FF Hex -> Program memory= 1300~14FF Hex 11: 100~3FF Hex -> Program memory= 1300~15FF Hex
9:8	RAM0_CFG[1:0]	Assign program memory area on RAM bank0 00: Program memory= None 01: 300~3FF Hex -> Program memory= 1200~12FF Hex 10: 200~3FF Hex -> Program memory= 1100~12FF Hex 11: 100~3FF Hex -> Program memory= 1000~12FF Hex
7:6	SBCK[1:0]	Select Bit Clock 00:32 FS, 01:48 FS, 10:64 FS
5:3	SDOF[2:0]	Select Output format (EIAJ /IIS, 16/18/20/24)
2:0	SDIF[2:0]	Select Input format (EIAJ /IIS, 16/18/20/24)

Digital Audio Interface

Digital audio interface (SIPO/PISO) has three 3 serial inputs and 4 serial outputs for the 6 channel input and the 8 channel output. It supports 16/18/20/24 bit EIAJ (right-justified) and IIS (left-justified) format. The SIPO/PISO unit interrupts DSP core after serial in/out completion. The left and right channels are distinguished by USR0 and USR1 flag as follows:

- L-ch Input: INT1=1, USR0=0, R-ch Input: INT1=1, USR0=1
- L-ch Output: INT2=1, USR1=0, R-ch Input: INT2=1, USR1=1

Table 4. Word / Bit Clock Control

Control		Description	Remark
IBCC	0	Synchronize with falling edge of BCKI	
	1	Synchronize with rising edge of BCKI	
OBCC	0	Synchronize with falling edge of BCKO	
	1	Synchronize with rising edge of BCKO	
LRCC	0	LRCKI(LRCKO)=L; L-ch data In/Out (default)	Controlled by HOST
	1	LRCKI(LRCKO)=H; L-ch data In/Out	

Table 5. Data Input Format

	Control			Output Data Format	Remark
	SDIF[2]	SDIF[1]	SDIF[0]		
Right-justify (EIAJ)	0	0	0	MSB first 16 bit, 32/48/64 fs	Slave Mode
	0	0	1	MSB first 18 bit, 48/64 fs	
	0	1	0	MSB first 20 bit, 48/64 fs	
	0	1	1	MSB first 24 bit, 48/64 fs	
Left-justify (IIS)	1	0	0	16 bit, 32/48/64 fs	
	1	0	1	18 bit, 48/64 fs	
	1	1	0	20 bit, 48/64 fs	
	1	1	1	24 bit, 48/64 fs	

Figure 5. Timing Diagram of Input Format

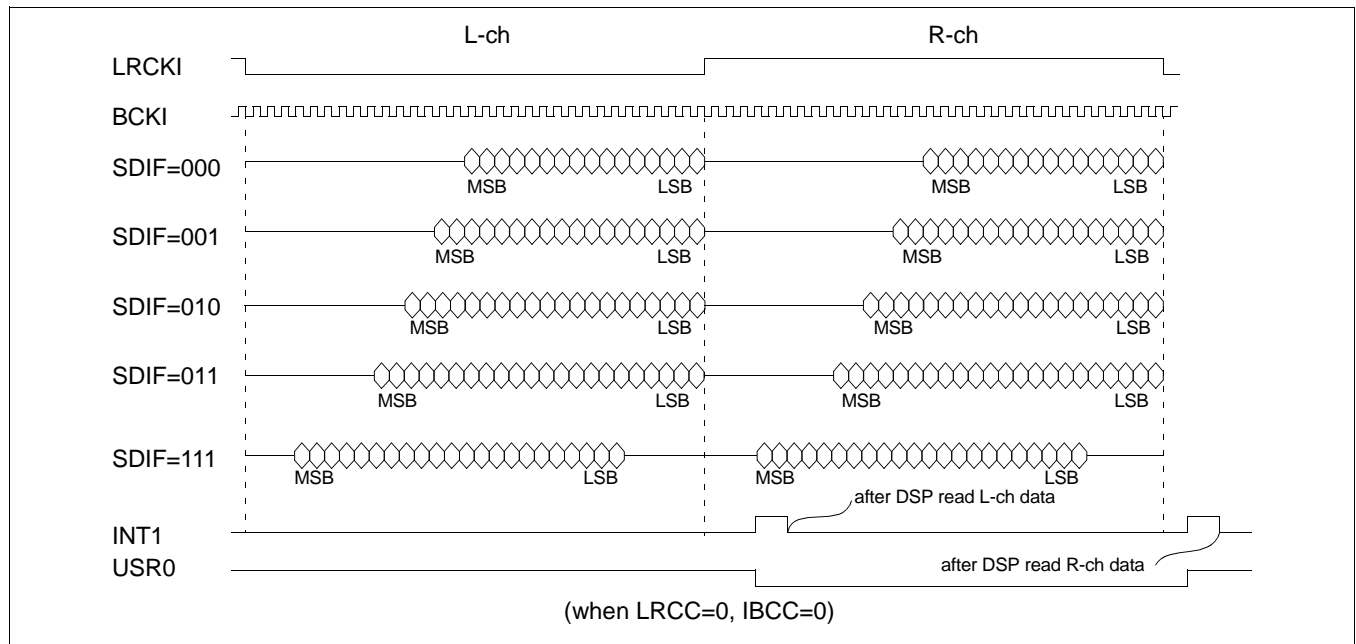
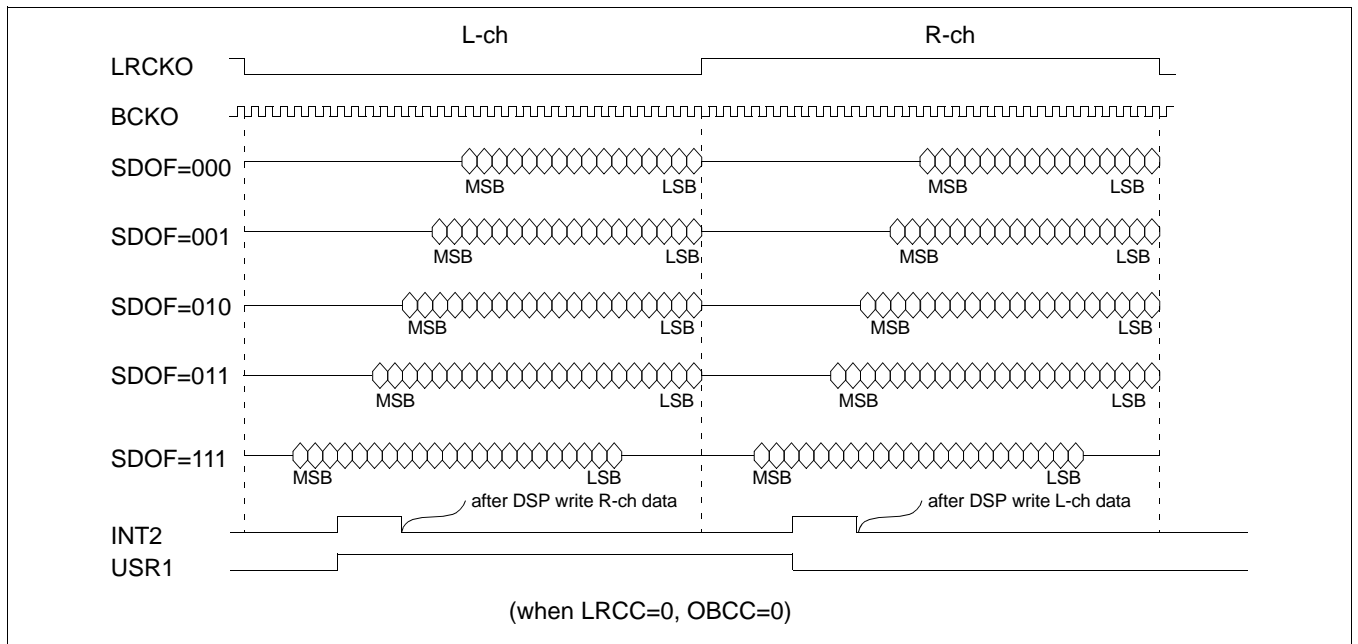

Table 6. Data Output Format

	Control			Output Data Format	Remark
	SDOF[2]	SDOF[1]	SDOF[0]		
Right-justify (EIAJ)	0	0	0	MSB first 16 bit, 32/48/64 fs	Slave Mode
	0	0	1	MSB first 18 bit, 48/64 fs	
	0	1	0	MSB first 20 bit, 48/64 fs	
	0	1	1	MSB first 24 bit, 48/64 fs	
Left-justify (IIS)	1	0	0	16 bit, 32/48/64 fs	
	1	0	1	18 bit, 48/64 fs	
	1	1	0	20 bit, 48/64 fs	
	1	1	1	24 bit, 48/64 fs	

Figure 6. Timing Diagram of Output Format



Host Interface

The KD16902 receives commands and parameters in serial format from the host through the host interface unit (HIU). The data is in byte unit. The HIU has HWEN (Host Write Enable), HBCK (Host Bit Clock), and SHI (Serial Host Input) pins. The maximum HBCK frequency is 5MHz. The KD16902 can accept host interrupt for every 60 machine cycles. However, the host should interrupt the KD16902 for every 3 sampling period to meet real time constraint. Host sends information through host interface unit as follows:

Figure 7. Timing Diagram of Host Interface

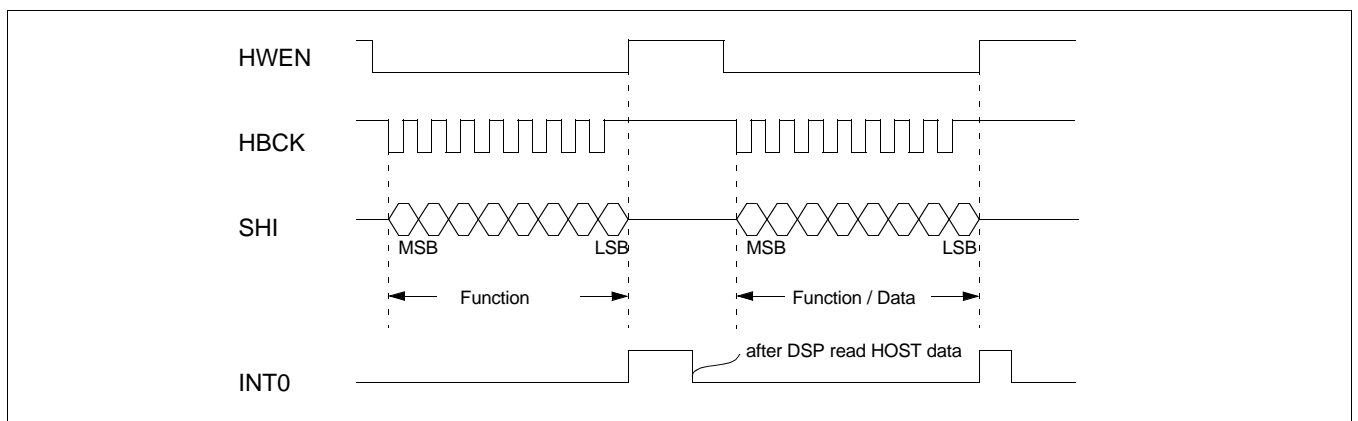

3 FUNCTIONAL DESCRIPTION

The KD16902 processor provides five functional modes. These modes, shown in Table 7, are selected by the command sent from the host. At the start or reset, the KD16902 stays idle and waits for the mode selection from the host. The KD16902 starts processing the corresponding functions after the mode selection.

Two different kinds of audio outputs exist in the KD16902. The first one is the two channel VCR output which is in turn input to VCR after being converted into analog by an external DAC. This feature is very useful for recording DVD output into VCR tape. The audio signal is recorded into VCR tape with the virtualizing effect, or downmix in case of mode 3. The second output is the speaker output. The audio is reproduced to speakers through this output. The KD16902 supports up to six channel output.

Table 7. Functional Modes

Mode	Function		Description
	Speaker Output	VCR Output	
1	2 Channel Virtual Surround	2 Channel Virtual Surround	For two speaker system
2	Multi Channel Virtual Surround	2 Channel Virtual Surround	For three or more speaker system
3	Bass Redirection	Downmix	The bass part of selected channels are redirected to other channels
4	Bypass	2 Channel Virtual Surround	Output is the original Dolby Digital audio
5	User Written Program	User Written Program	For downloading and executing user written program

Functional Modes

Mode-1

Figure 8. Mode 1

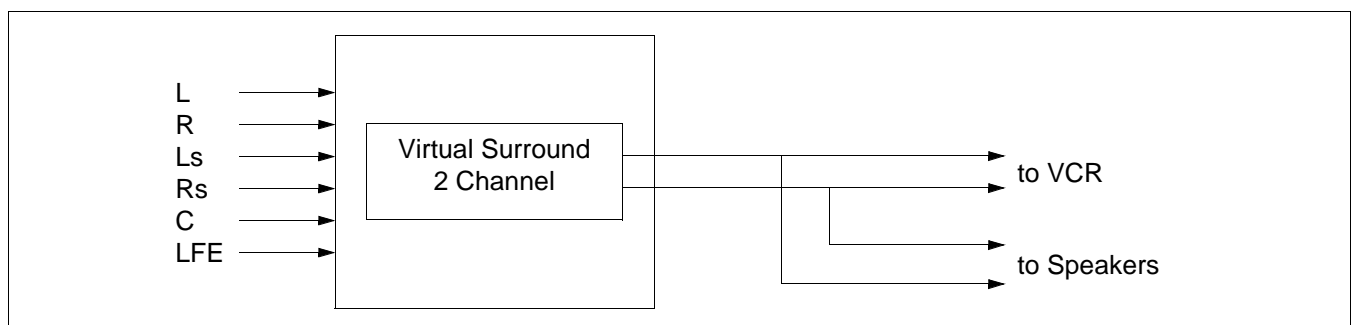

The mode 1 is used for two speaker systems. Dolby Digital bit stream requires up to six speakers to reproduce the audio properly. In this mode, the audio is reproduced using two speakers with the virtual surround effect. Since the number of channels for VCR output is always two, the output for the VCR output and the speaker output are the same as shown in Figure 8.

Mode-2

Figure 9. Mode 2

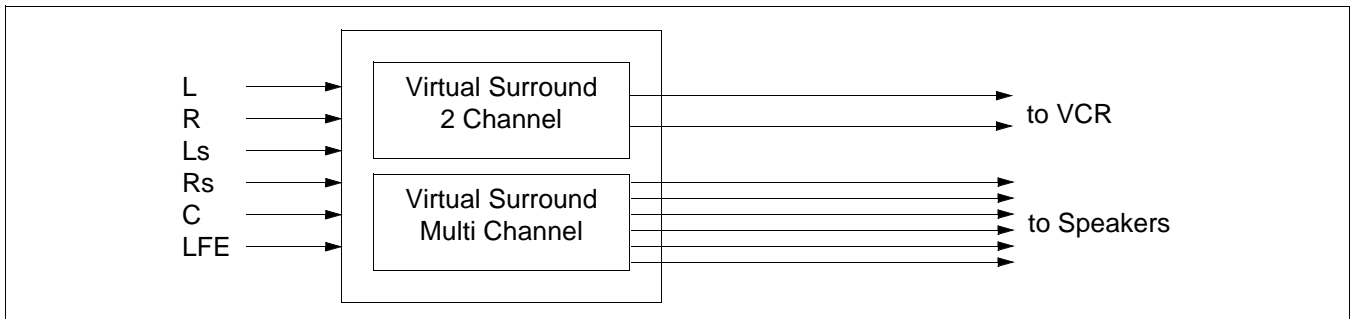

When the consumer has more than two speakers, mode 2 can be used. In this mode, the output of Dolby Digital is converted into the output mode set up by the consumer. For example, when the consumer has L,R, and C speakers (3/0 output mode), then the KD16902 converts the output of Dolby Digital into this mode using the Virtual Surround function. Even for the six speaker system, this mode enhances the surround effect by spreading the sound into wider area. For the VCR output, Dolby Digital output is converted into two channels using the Virtual Surround function.

Mode-3

Figure 10. Mode 3

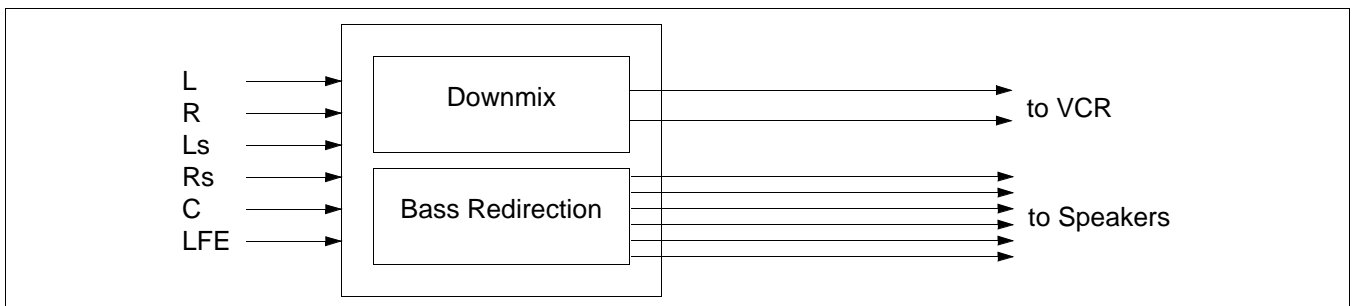

The mode 3 can be used when the consumer has six speakers but some of the speakers are small satellite speakers, which can distort the bass signals. The bass redirection function redirects the very low frequency parts of the channels with the small speakers into the channels for which speakers can reproduce the bass signals. In this mode, Dolby Digital's output is downmixed into two channels for the VCR output.

Mode 4

Figure 11. Mode 4

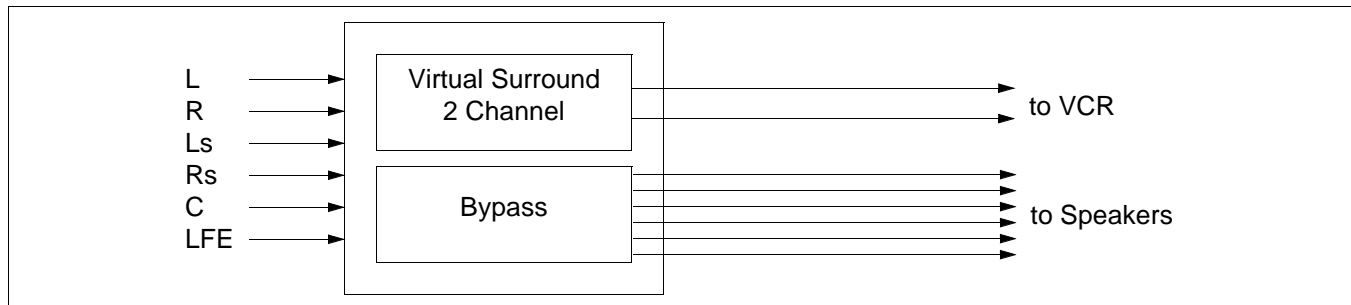

When the consumer wishes to hear the original Dolby Digital audio, mode 4 can be selected. The output of the Dolby Digital decoder is simply bypassed. For VCR output, the Virtual Surround function is applied.

Mode 5

Figure 12. Mode 5

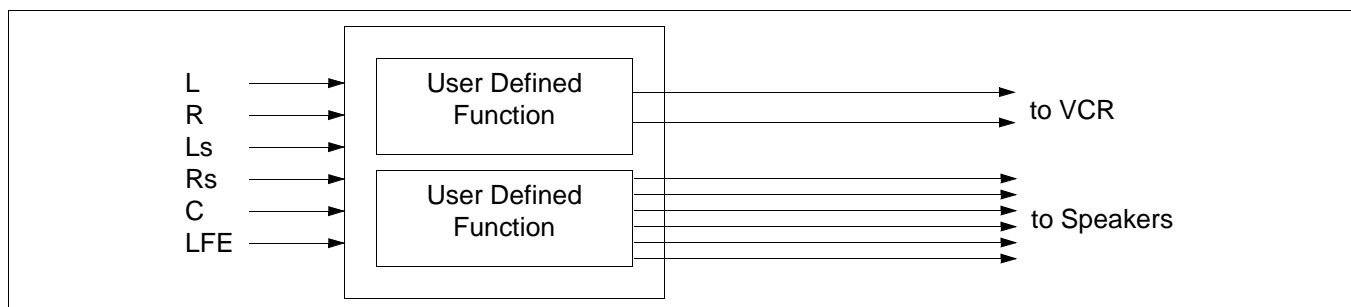

The mode 5 is used for downloading and executing the user written program. The KD16902 download the user written program into its internal RAM. In this mode, the user written codes are downloaded first. Then, the KD16902 starts execute the user written program after accepting the corresponding command.

Virtual Surround

An output of Dolby Digital may require up to six speakers to reproduce the audio properly. The Virtual Surround function, developed by QSound Labs, Inc, accepts output of Dolby Digital and converts it into two or more channel audio, depending on number of speakers available, with the surround effect.

The host sends the following parameters:

- Input/Output channel mode
- LFE On/Off
- Sampling frequency
- Bit resolution
- Audible area control

Figure 13. Virtual Surround Function

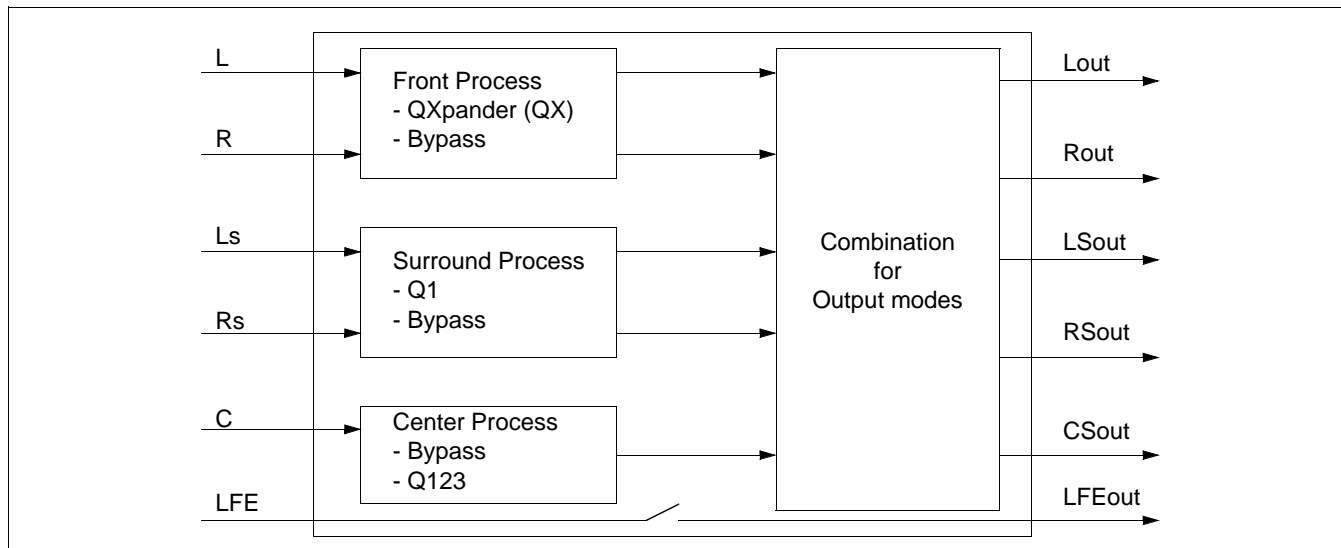

There are three main parts, licensed from QSound Labs, Inc., within the Virtual Surround function. First one is QXpander™ (QX™) which is used for the front channels. QXpander expands the separation between left and right channels, thus enhancing the front channels. Second part is the Q1™ which is applied to the surround channels. The Q1 provides discrete virtualization of the surround channels such that they are properly positioned with respect to the front channels regardless of output configuration. The Q1 automatically compensates for "omni" (mono) surround content as is typical of Dolby Pro Logic content that may be repackaged in a Dolby Digital System. The last part is the Q123™ for the center channel. It converts a mono signal into stereo signal. Depending on input and output combination, a phantom operation instead of Q123 can be applied to center signal. The phantom operation simply redirects the center signal into front speakers. The output of these three parts are combined appropriately to yield the surround audio with 5 or less number of speakers. If the consumer has a subwoofer speaker, the LFE channel is simply bypassed by setting the LFE on/off parameter.

QXpander, Q1, and Q123 are protected by U.S. patent nos. 5,105,462, 5,208,860 and 5,440,638 and various foreign counterparts, and are copyright QSound Labs, Inc., 1993 - 1997. QXpander, QX, Q1, and Q123 are trademarks of QSound Labs, Inc.

The advantage of the KD16902 is that the input and output are not constrained to 5.1 channel and 2 channels, respectively. The KD16902 can accept any input mode, and the output can be any speaker combination. The exception is 1+1 mode. The 1+1 mode is not supported in the KD16902. Table 8 summarizes the combination of input and output modes supported by the KD16902. The input mode used here is the term for the audio coding mode of the Dolby Digital bit stream. The output mode specifies the speaker combination. The terms, i.e., 3/2 for the output mode is same as those used for the input mode.

Table 8. Input and Output Modes for Virtual Surround Function

Input Mode	Output Mode	Output Description
1/0	1/0	Center Only
2/0		
3/0		
2/1		
3/1		
2/2		
3/2		
1/0	2/0	Left Front and Right Front
2/0		
3/0		
2/1		
3/1		
2/2		
3/2		
1/0	3/0	Left Front, Right Front, and Center
2/0		
3/0		
2/1		
3/1		
2/2		
3/2		
1/0	2/1	Left Front, Right Front, and Mono Surround
2/0		
3/0		
2/1		
3/1		
2/2		
3/2		

Table 8. Input and Output Modes for Virtual Surround Function

Input Mode	Output Mode	Output Description
1/0	3/1	Left Front, Right Front, Center, and Mono Surround
2/0		
3/0		
2/1		
3/1		
2/2		
3/2		
1/0	2/2	Left Front, Right Front, Left Surround, and Right Surround
2/0		
3/0		
2/1		
3/1		
2/2		
3/2		
1/0	3/2	Left Front, Right Front, Center, Left Surround, and Right Surround
2/0		
3/0		
2/1		
3/1		
2/2		
3/2		

The audible area control parameter specifies the range of area, in which a person can hear the surround effect. Figure 14 shows the audible area for the two speaker system. As the parameter value decreases, the audible area becomes wider. There is trade off between the range of audible area and the surround effect. The surround effect becomes more dramatic as the audible area decreases. Table 9 shows the range of the parameter for each sampling frequency.

Figure 14. Audible Area for Two Speaker System

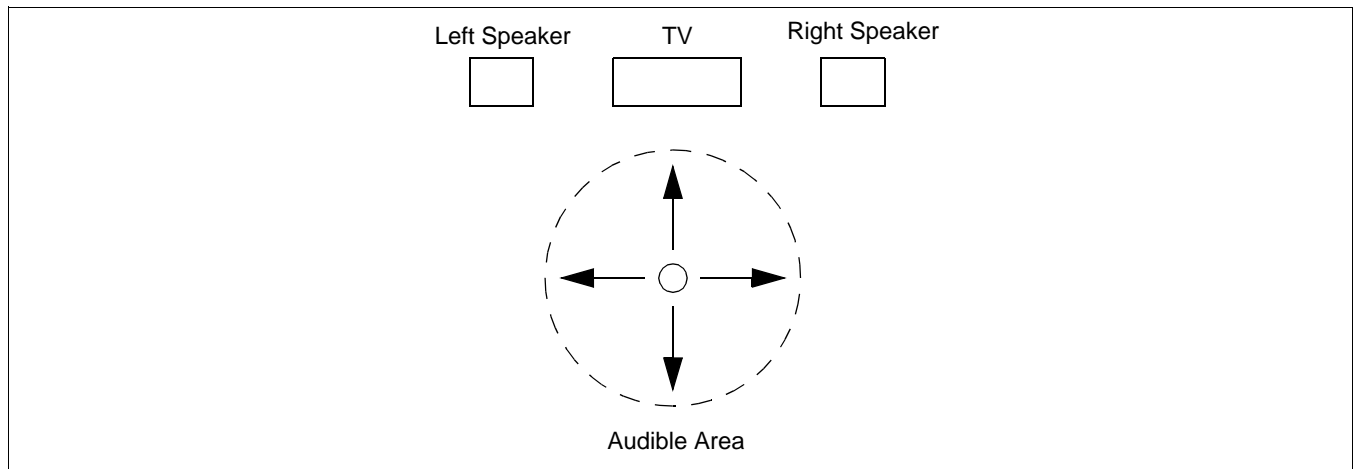

Table 9. Range of Audible Area Parameter

Sampling Frequency	Smallest Audible Area	Greatest Audible Area
32 KHz	0x1A00	0x0A00
44.1 KHz	0x12DD	0x0741
48 KHz	0x1155	0x06aa

Following is the set of default values for the parameters used in Virtual Surround function.

Table 10. Default Values for the Parameters used in the Virtual Surround Function

Command Name	Command Code	Parameter Value	Description
Input Channel Mode	0x09	0x0f	Input Channel Mode is 3/2 and LFE channel is on
Output Channel Mode	0x0a	0x02	Output Channel Mode is 2/0
Sampling Frequency	0x0b	0x00	48 KHz
Input Data Format	0x0c	0x00	Input sample resolution is 16 bits and left justification
Output Data Format	0x0d	0x00	Output sample resolution is 16 bits and left justification
Audible Area Control, High	0x15	0x11	Audible Area Control value is 0x1155
Audible Area Control, Low	0x16	0x55	Audible Area Control value is 0x1155

Bass Redirection

The KD16902 offers the bass redirection function for the consumers with small satellite speakers for some channels. Dolby offers several output configurations for bass management. The KD16902 can perform the bass redirection all configurations required by Dolby. This feature saves cost for the DVDP or any other system with Dolby Digital decoder because the system does not require separate circuit for bass management.

Figure 15 to Figure 18 shows the output configurations required by Dolby. Please note that the KD16902 does not offer analog amplifying gains for LFE signals. These have to done by the analog circuit in the system. The surround inputs to the summing stages in Figure 15, Figure 16, and Figure 18 is removed for Dolby Pro Logic Mode.

Figure 15. Output Configuration 1

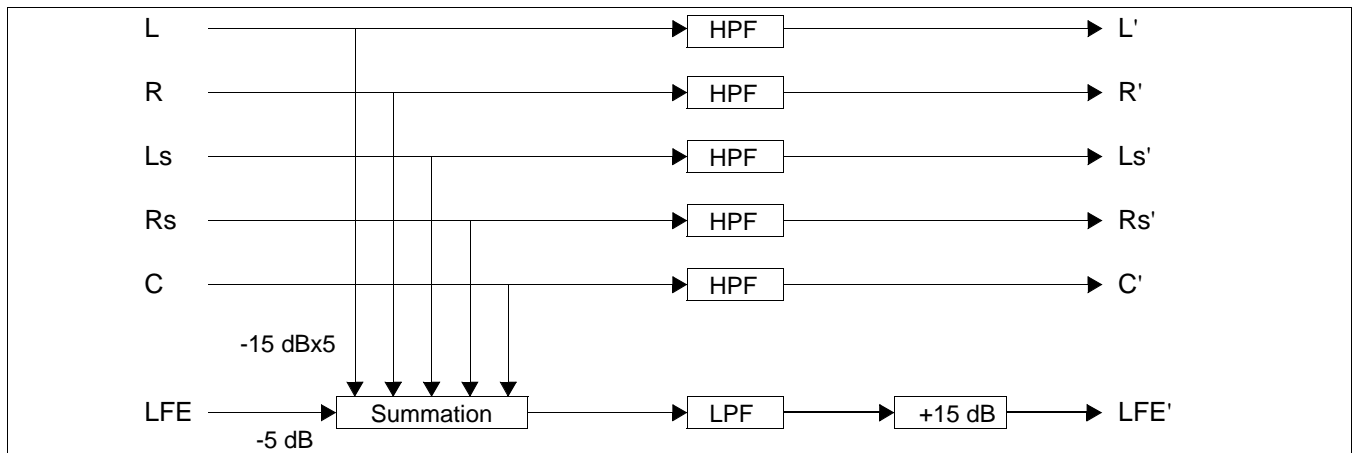

Figure 16. Output Configuration 2

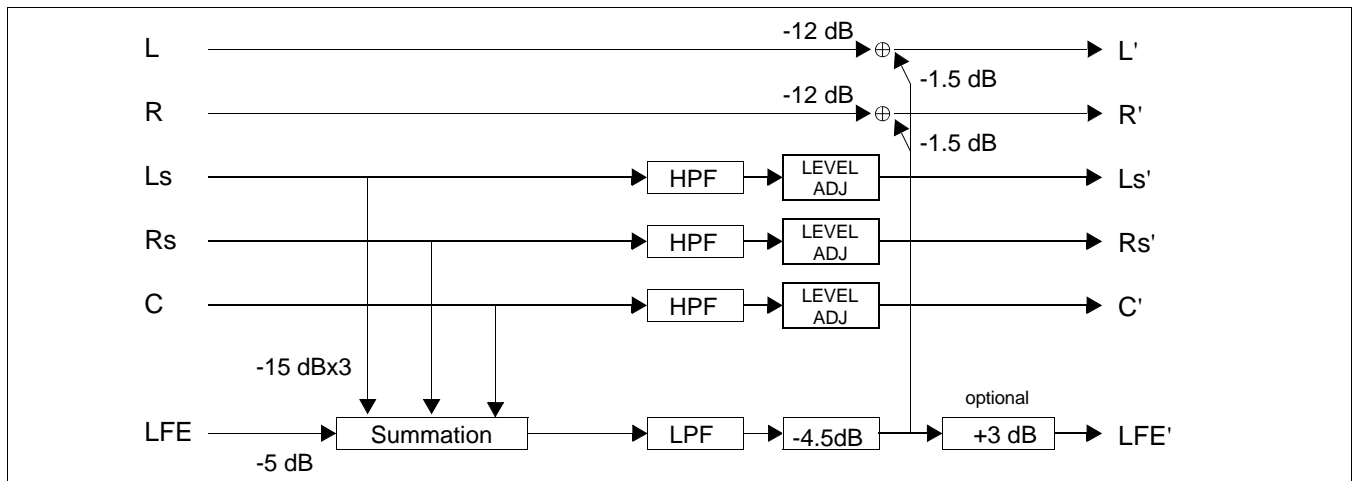

Figure 17. Output Configuration 3.

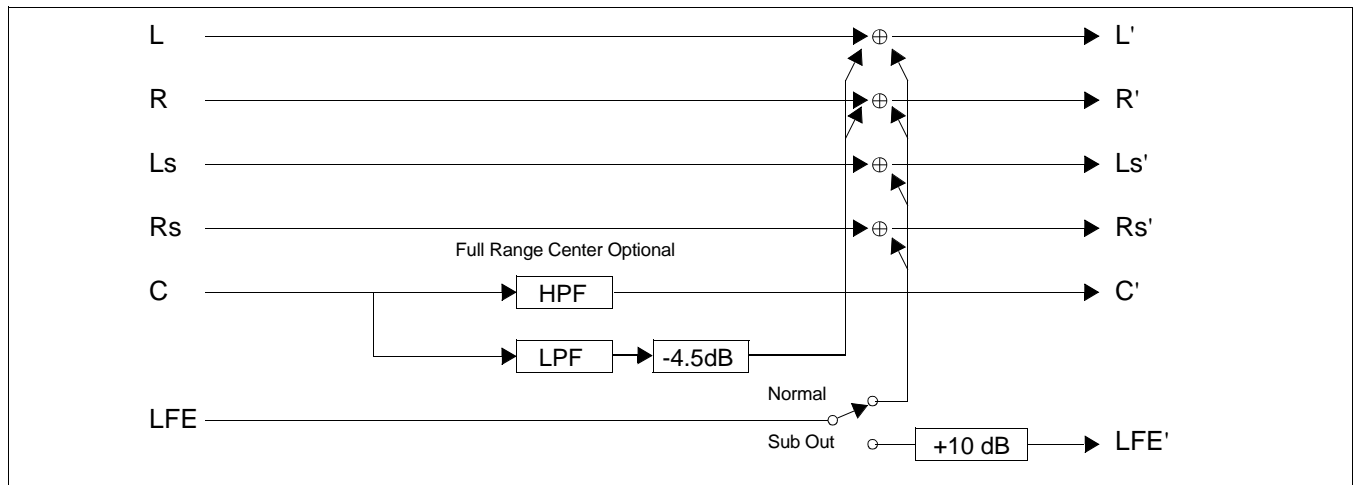
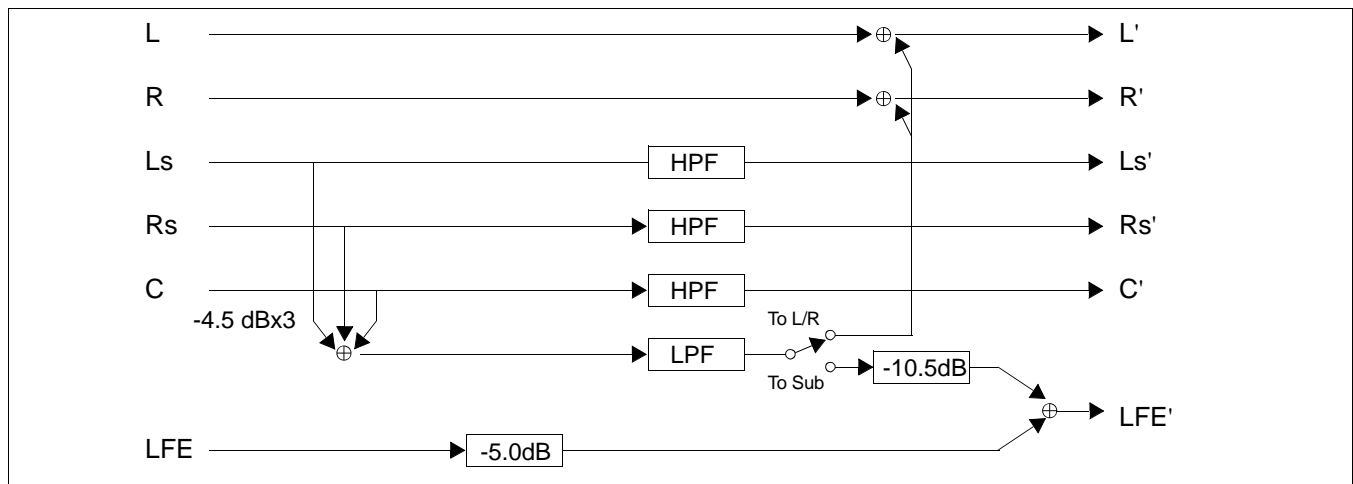

Figure 18. Simplified Configuration



The bass redirection function, shown in Figure 19, in the KD16902 can accommodate any output configuration. For Dolby Pro Logic mode, the surround input to the bass summing stages can be removed by setting the corresponding gain to zero. The processor needs the following parameters from the host to process a selected configuration.

- Sampling Frequency
- Filter switches
- Gain coefficients
- LFE redirection switches

Following is the list of the commands needed for bass redirection function with the corresponding terms shown in Figure 19.

Table 11. Commands used for Bass Redirection

Command Name	Command Code	Term in Figure 17
Filter Switches	0x19	f1, f2, f3, f4, f5
LFE Redirection Switches	0x1a	s1, s2, s3, s4
Gain of Front for Summation 1	0x1b and 0x1c	g1
Gain of Rear for Summation 2	0x1d and 0x1e	g2
Gain of Center for Summation 3	0x1f and 0x20	g3
Gain of Front for Summation 4	0x21 and 0x22	g4
Gain of Rear for Summation 4	0x23 and 0x24	g5
Gain of Center for Summation 4	0x25 and 0x26	g6
Gain of LPF Output for Summation 1	0x27 and 0x28	g7
Gain of LPF Output for Summation 2	0x29 and 0x2a	g8
Gain of LPF Output for Summation 3	0x2b and 0x2c	g9
Gain of LFE for LFE Summation	0x2d and 0x2e	g10
Gain of Front for LFE Summation	0x2f and 0x30	g11
Gain of Rear for LFE Summation	0x31 and 0x32	g12
Gain of Center for LFE Summation	0x33 and 0x34	g13
Gain of Front before Output	0x35 and 0x36	g14
Gain of Rear before Output	0x37 and 0x38	g15
Gain of Center before Output	0x39 and 0x3a	g16
Gain of LFE before Output	0x3b and 0x3c	g17

Following table describes the summations. The LPF mentioned in the table is the low pass filter after summation of front, rear, and center signals.

Table 12. Summations in Bass Redirection

Summation Name	Description
Summation 1	Summation of front and LPF output
Summation 2	Summation of rear and LPF output
Summation 3	Summation of center and LPF output
Summation 4	Summation front, rear, and center
LFE Summation	Summation of all six inputs

Figure 19. Bass Redirection Function

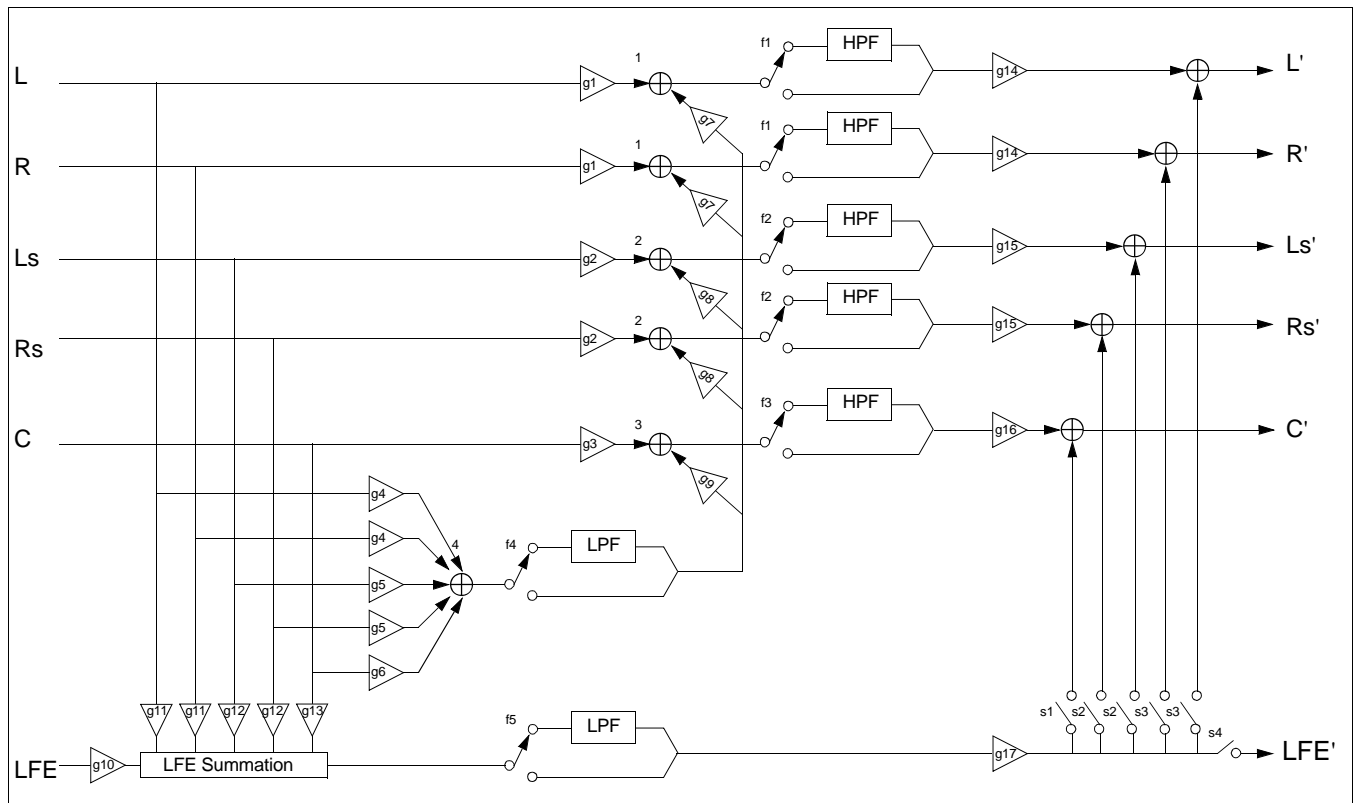

The KD16902 is based on the DSP core with 16 bit fixed point precision. Therefore, the gains are used for scaling down the signals before the summations to avoid overflow. The gains, g14 to g16, are either used for balancing the output levels of the five main channels or scaling before the addition with LFE signal. Since the overall output of Dolby Digital decoder is attenuated, the system should increase the output level of bass redirection appropriately to the user desired level.

Example:

Suppose, the user wants to add the front signals and the output of the LPF. The user chose to attenuate both signals equally by 6 dB using g1 and g7 respectively to avoid possible overflow.

Then, the rear and the center signals must be attenuated by 6 dB before output using g15 and g16 to preserve the output level balance. Also, the system should increase the output level of the KD16902 by 6 dB.

The parameter values of the switches for the basic output configurations are listed in Table 13 through Table 18. Samsung recommends gain values for the basic configurations. The recommended values for the gains are listed in Table 19 through Table 24. The values listed in the tables are for Dolby Digital mode. For Dolby Pro Logic mode, the values should be set appropriately. The default configuration is Configuration 1. Therefore, the values listed in Table 13 and Table 19 are the default parameters. The default sampling frequency is 48 kHz.

Table 13. Switch Parameters for Configuration 1

Command Name	Command Name	Parameter Values
Filter Switches	0x19	0x17
LFE Redirection Switches	0x1a	0x08

Table 14. Switch Parameters for Configuration 2

Command Name	Command Name	Parameter Values
Filter Switches	0x19	0x16
LFE Redirection Switches	0x1a	0x04

Table 15. Switch Parameters for Configuration 3 with Normal Mode

Command Name	Command Name	Parameter Values
Filter Switches	0x19	0x0c
LFE Redirection Switches	0x1a	0x08

Table 16. Switch parameters for Configuration 3 with Sub Out Mode

Command Name	Command Name	Parameter Values
Filter Switches	0x19	0x0c
LFE Redirection Switches	0x1a	0x06

Table 17. Switch Parameters for Simplified Configuration with "To L/R" Mode

Command Name	Command Name	Parameter Values
Filter Switches	0x19	0x0e
LFE Redirection Switches	0x1a	0x08

Table 18. Switch Parameters for Simplified Configuration with "To Sub" Mode

Command Name	Command Name	Parameter Values
Filter Switches	0x19	0x16
LFE Redirection Switches	0x1a	0x08

Table 19. Recommended Gain Values for Configuration 1

Command Name	Command Code		Parameter Value		dB Representation
	High	Low	High	Low	
Gain of Front for Summation 1	0x1b	0x1c	0x7f	0xff	0 dB
Gain of Rear for Summation 2	0x1d	0x1e	0x7f	0xff	0 dB
Gain of Center for Summation 3	0x1f	0x20	0x7f	0xff	0 dB
Gain of Front for Summation 4	0x21	0x22	0x00	0x00	- ∞ dB
Gain of Rear for Summation 4	0x23	0x24	0x00	0x00	- ∞ dB
Gain of Center for Summation 4	0x25	0x26	0x00	0x00	- ∞ dB
Gain of LPF Output for Summation 1	0x27	0x28	0x00	0x00	- ∞ dB
Gain of LPF Output for Summation 2	0x29	0x2a	0x00	0x00	- ∞ dB
Gain of LPF Output for Summation 3	0x2b	0x2c	0x00	0x00	- ∞ dB
Gain of LFE for LFE Summation	0x2d	0x2e	0x47	0xef	-5 dB
Gain of Front for LFE Summation	0x2f	0x30	0x16	0xc8	-15 dB
Gain of Rear for LFE Summation	0x31	0x32	0x16	0xc8	-15 dB
Gain of Center for LFE Summation	0x33	0x34	0x16	0xc8	-15 dB
Gain of Front before Output	0x35	0x36	0x7f	0xff	0 dB
Gain of Rear before Output	0x37	0x38	0x7f	0xff	0 dB
Gain of Center before Output	0x39	0x3a	0x7f	0xff	0 dB
Gain of LFE before Output	0x3b	0x3c	0x7f	0xff	0 dB

Table 20. Recommended Gain Values for Configuration 2

Command Name	Command Code		Parameter Value		dB Representation
	High	Low	High	Low	
Gain of Front for Summation 1	0x1b	0x1c	0x7f	0xff	0 dB
Gain of Rear for Summation 2	0x1d	0x1e	0x7f	0xff	0 dB
Gain of Center for Summation 3	0x1f	0x20	0x7f	0xff	0 dB
Gain of Front for Summation 4	0x21	0x22	0x00	0x00	- ∞ dB
Gain of Rear for Summation 4	0x23	0x24	0x00	0x00	- ∞ dB
Gain of Center for Summation 4	0x25	0x26	0x00	0x00	- ∞ dB
Gain of LPF Output for Summation 1	0x27	0x28	0x00	0x00	- ∞ dB
Gain of LPF Output for Summation 2	0x29	0x2a	0x00	0x00	- ∞ dB
Gain of LPF Output for Summation 3	0x2b	0x2c	0x00	0x00	- ∞ dB
Gain of LFE for LFE Summation	0x2d	0x2e	0x47	0xef	-5 dB
Gain of Front for LFE Summation	0x2f	0x30	0x00	0x00	- ∞ dB
Gain of Rear for LFE Summation	0x31	0x32	0x16	0xc8	-15 dB
Gain of Center for LFE Summation	0x33	0x34	0x16	0xc8	-15 dB
Gain of Front before Output	0x35	0x36	0x20	0x20	-12 dB
Gain of Rear before Output	0x37	0x38	0x20	0x20	-12 dB
Gain of Center before Output	0x39	0x3a	0x20	0x20	-12 dB
Gain of LFE before Output	0x3b	0x3c	0x6b	0xa5	-1.5 dB

Table 21. Recommended Gain Values for Configuration 3 with Normal Mode

Command Name	Command Code		Parameter Value		dB Representation
	High	Low	High	Low	
Gain of Front for Summation 1	0x1b	0x1c	0x50	0xc4	-4 dB
Gain of Rear for Summation 2	0x1d	0x1e	0x7f	0xff	0 dB
Gain of Center for Summation 3	0x1f	0x20	0x7f	0xff	0 dB
Gain of Front for Summation 4	0x21	0x22	0x00	0x00	-∞ dB
Gain of Rear for Summation 4	0x23	0x24	0x00	0x00	-∞ dB
Gain of Center for Summation 4	0x25	0x26	0x7f	0xff	0 dB
Gain of LPF Output for Summation 1	0x27	0x28	0x30	0x20	-8.5 dB
Gain of LPF Output for Summation 2	0x29	0x2a	0x00	0x00	-∞ dB
Gain of LPF Output for Summation 3	0x2b	0x2c	0x00	0x00	-∞ dB
Gain of LFE for LFE Summation	0x2d	0x2e	0x7f	0xff	0 dB
Gain of Front for LFE Summation	0x2f	0x30	0x00	0x00	-∞ dB
Gain of Rear for LFE Summation	0x31	0x32	0x00	0x00	-∞ dB
Gain of Center for LFE Summation	0x33	0x34	0x00	0x00	-∞ dB
Gain of Front before Output	0x35	0x36	0x7f	0xff	0 dB
Gain of Rear before Output	0x37	0x38	0x50	0xc4	-4 dB
Gain of Center before Output	0x39	0x3a	0x50	0xc4	-4 dB
Gain of LFE before Output	0x3b	0x3c	0x7f	0xff	0 dB

Table 22. Recommended Gain Values for Configuration 3 with Sub Out Mode

Command Name	Command Code		Parameter Value		dB Representation
	High	Low	High	Low	
Gain of Front for Summation 1	0x1b	0x1c	0x32	0xf1	-8 dB
Gain of Rear for Summation 2	0x1d	0x1e	0x7f	0xff	0 dB
Gain of Center for Summation 3	0x1f	0x20	0x7f	0xff	0 dB
Gain of Front for Summation 4	0x21	0x22	0x00	0x00	-∞ dB
Gain of Rear for Summation 4	0x23	0x24	0x00	0x00	-∞ dB
Gain of Center for Summation 4	0x25	0x26	0x7f	0xff	0 dB
Gain of LPF Output for Summation 1	0x27	0x28	0x1e	0x56	-12.5 dB
Gain of LPF Output for Summation 2	0x29	0x2a	0x00	0x00	-∞ dB
Gain of LPF Output for Summation 3	0x2b	0x2c	0x00	0x00	-∞ dB
Gain of LFE for LFE Summation	0x2d	0x2e	0x7f	0xff	0 dB
Gain of Front for LFE Summation	0x2f	0x30	0x00	0x00	-∞ dB
Gain of Rear for LFE Summation	0x31	0x32	0x00	0x00	-∞ dB
Gain of Center for LFE Summation	0x33	0x34	0x00	0x00	-∞ dB
Gain of Front before Output	0x35	0x36	0x7f	0xff	0 dB
Gain of Rear before Output	0x37	0x38	0x32	0xf1	-8 dB
Gain of Center before Output	0x39	0x3a	0x32	0xf1	-8 dB
Gain of LFE before Output	0x3b	0x3c	0x32	0xf1	-8 dB

Table 23. Recommended Gain Values for Simplified Configuration with "To L/R" Mode

Command Name	Command Code		Parameter Value		dB Representation
	High	Low	High	Low	
Gain of Front for Summation 1	0x1b	0x1c	0x7f	0xff	0 dB
Gain of Rear for Summation 2	0x1d	0x1e	0x7f	0xff	0 dB
Gain of Center for Summation 3	0x1f	0x20	0x7f	0xff	0 dB
Gain of Front for Summation 4	0x21	0x22	0x00	0x00	- ∞ dB
Gain of Rear for Summation 4	0x23	0x24	0x4c	0x49	-4.5 dB
Gain of Center for Summation 4	0x25	0x26	0x4c	0x49	-4.5 dB
Gain of LPF Output for Summation 1	0x27	0x28	0x7f	0xff	0 dB
Gain of LPF Output for Summation 2	0x29	0x2a	0x00	0x00	- ∞ dB
Gain of LPF Output for Summation 3	0x2b	0x2c	0x00	0x00	- ∞ dB
Gain of LFE for LFE Summation	0x2d	0x2e	0x7f	0xff	0 dB
Gain of Front for LFE Summation	0x2f	0x30	0x00	0x00	- ∞ dB
Gain of Rear for LFE Summation	0x31	0x32	0x00	0x00	- ∞ dB
Gain of Center for LFE Summation	0x33	0x34	0x00	0x00	- ∞ dB
Gain of Front before Output	0x35	0x36	0x7f	0xff	0 dB
Gain of Rear before Output	0x37	0x38	0x7f	0xff	0 dB
Gain of Center before Output	0x39	0x3a	0x7f	0xff	0 dB
Gain of LFE before Output	0x3b	0x3c	0x7f	0xff	0 dB

Table 24. Recommended Gain Values for Simplified Configuration with "To Sub" Mode

Command Name	Command Code		Parameter Value		dB Representation
	High	Low	High	Low	
Gain of Front for Summation 1	0x1b	0x1c	0x7f	0xff	0 dB
Gain of Rear for Summation 2	0x1d	0x1e	0x7f	0xff	0 dB
Gain of Center for Summation 3	0x1f	0x20	0x7f	0xff	0 dB
Gain of Front for Summation 4	0x21	0x22	0x00	0x00	- ∞ dB
Gain of Rear for Summation 4	0x23	0x24	0x00	0x00	- ∞ dB
Gain of Center for Summation 4	0x25	0x26	0x00	0x00	- ∞ dB
Gain of LPF Output for Summation 1	0x27	0x28	0x00	0x00	- ∞ dB
Gain of LPF Output for Summation 2	0x29	0x2a	0x00	0x00	- ∞ dB
Gain of LPF Output for Summation 3	0x2b	0x2c	0x00	0x00	- ∞ dB
Gain of LFE for LFE Summation	0x2d	0x2e	0x47	0xef	-5.0 dB
Gain of Front for LFE Summation	0x2f	0x30	0x00	0x00	- ∞ dB
Gain of Rear for LFE Summation	0x31	0x32	0x16	0xc8	-15 dB
Gain of Center for LFE Summation 4	0x33	0x34	0x16	0xc8	-15 dB
Gain of Front before Output	0x35	0x36	0x7f	0xff	0 dB
Gain of Rear before Output	0x37	0x38	0x7f	0xff	0 dB
Gain of Center before Output	0x39	0x3a	0x7f	0xff	0 dB
Gain of LFE before Output	0x3b	0x3c	0x7f	0xff	0 dB

User Defined Function

The KD16902 has additional flexibility of processing user defined function. The user written program is downloaded and executed in Mode 5. Mode 5 is divided into two stages. First, the user written program is downloaded from the host to the internal RAM. The KD16902, then, starts execute the user defined program after accepting the corresponding command from the host.

To go to other mode in Mode 5, the KD16902 must be reset using the reset command before accepting the mode selection command. Otherwise, the KD16902 will ignore the mode selection and keep execute the user defined function.

Program Download and Execution

The KD16902 has two internal RAM banks, RAM0 and RAM1. Each bank, with size of 1K words, is further divided into four pages. The user is allowed to use last three pages for both banks. *The user is not allowed write to page 0 of both RAM0 and RAM1. However, reading from the page 0 is allowed.* This makes total 1.5K words of internal RAM available for the user written codes.

After downloading, the user must configure the internal RAM into program memory and data memory. The KD16902 uses RAM0_CFG[1:0] and RAM1_CFG[1:0] bits of ext5 register for the memory configuration. Table 3 describes the bit assignment to ext5 register. The program memory is memory mapped into program address space. Table 25, Table 26, and Figure 20 show the memory configuration and program address map.

Table 25. Memory Configuration for RAM0

RAM0_CFG[1:0]	Data Memory	Program Memory	Program Address
00	pages 0, 1, 2, and 3	-	-
01	pages 0, 1, and 2	page 3	0x1200 to 0x12FF
10	pages 0 and 1	pages 2 and 3	0x1100 to 0x12FF
11	page 0	pages 1, 2, and 3	0x1000 to 0x12FF

Table 26. Memory Configuration for RAM1

RAM1_CFG[1:0]	Data Memory	Program Memory	Program Address
00	pages 0, 1, 2, and 3	-	-
01	pages 0, 1, and 2	page 3	0x1300 to 0x13FF
10	pages 0 and 1	pages 2 and 3	0x1300 to 0x14FF
11	page 0	pages 1, 2, and 3	0x1300 to 0x15FF

Figure 20. Program Memory Address Map

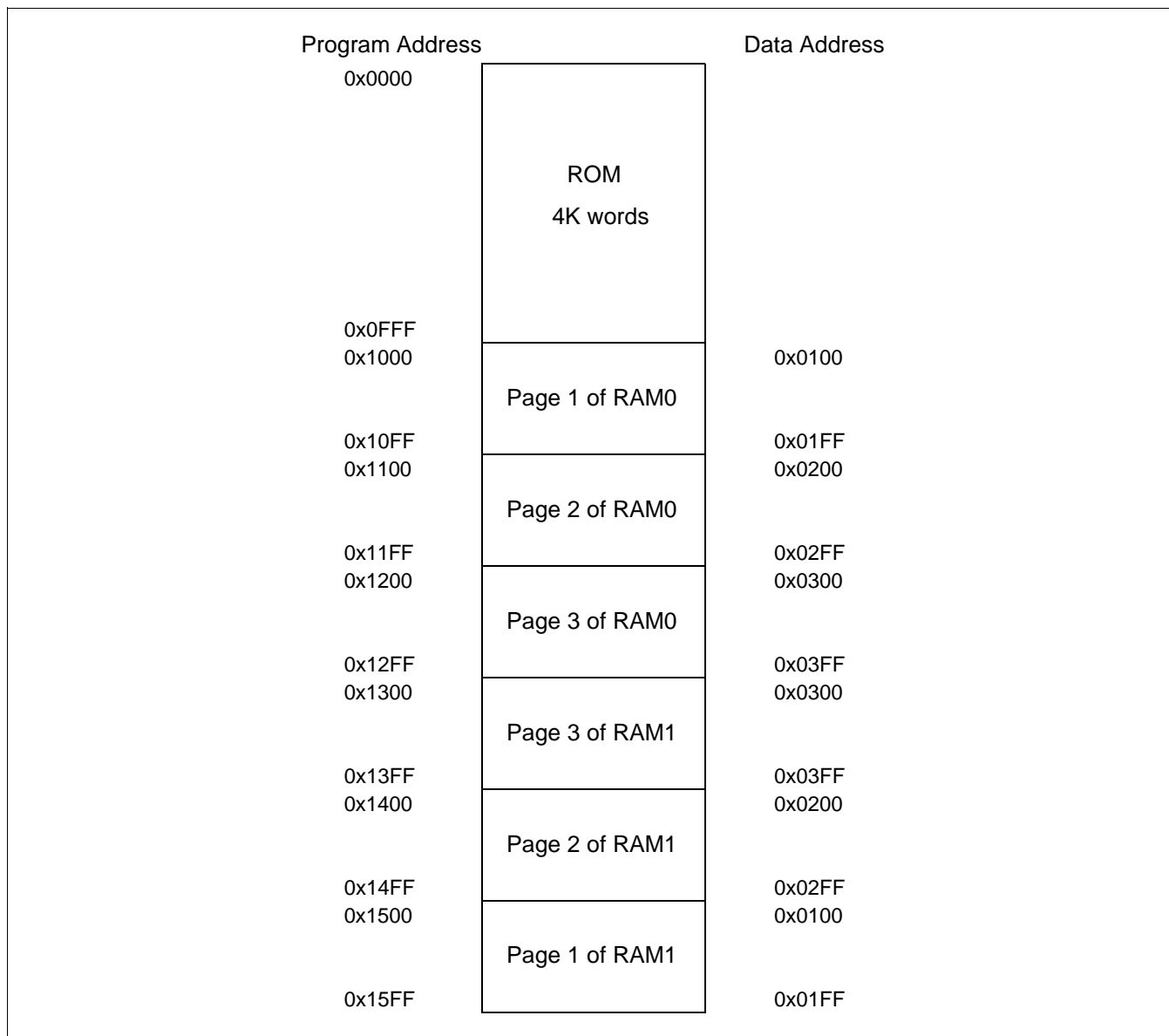

The host sends the Program Memory Configuration command for the memory configuration. The parameter following the command contains the information for RAM0_CFG[1:0] and RAM1_CFG[1:0]. The command and its parameter are defined in the next section. When the KD16902 accepts the parameter, the parameter's bit[3:2] and bit[1:0] are copied to RAM0_CFG[1:0] and RAM1_CFG[1:0] bits of ext5 register, respectively.

Table 27 shows the commands used for the downloading. The host sends the address and the code using these commands. The address and the code are divided into upper and lower bytes because the KD16902 only accepts data in unit of byte. *The data address, instead program address, is used for the downloading.* The address is in 10 bits since the bank size is 1024 words. The bit[7:0] of the data address are assigned to the parameter following the RAM Address, Low command. The bit[9:8], which indicates the RAM page, are assigned the lowest significant 2 bits of the parameter following the RAM Address, High command. The bit 7 of the parameter indicates the bank. It is set to 0 for RAM0 and 1 for RAM1. Figure 21 shows the parameter.

Table 27. Commands Used for Downloading User Written Code

Command	Command Code	Parameter Description
RAM Address, High	0x3e	Flag for banks and upper 2 bits of the address
RAM Address, Low	0x3f	Lower byte of the address
RAM Data, High	0x40	Upper byte of the code
RAM Data, Low	0x41	Lower byte of the code

Figure 21. Parameters for Data Address

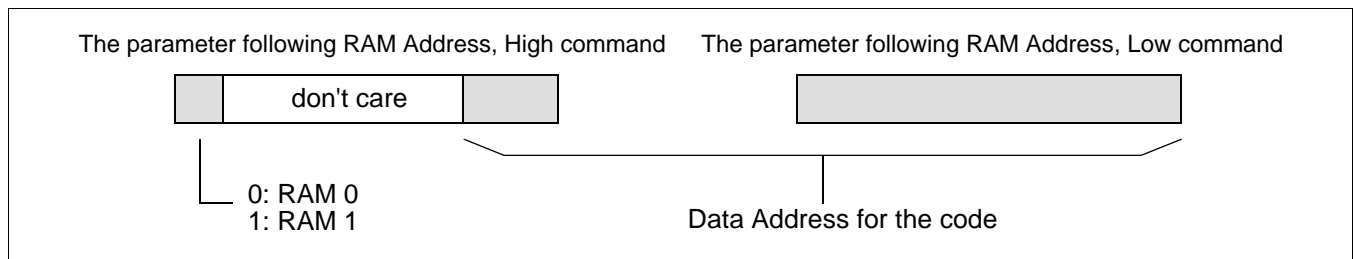

After finishing the downloading and setting memory configuration, the host sends Jump to Program Memory Address commands to start execution. After accepting these commands, the KD16902 constructs the starting address from the parameters following the commands. The address is loaded into the pc. *Please note that the program address is used for the Jump to Program Address commands.*

In Mode 5, the KD16902 can accept commands and parameters before executing the user defined program. *After accepting the Jump to Program Memory Address commands, the KD16902 ignores the commands sent from the host except the Reset command.*

Example:

The user wants to configure page 3 of RAM0 and pages 2 and 3 of RAM1 to program memory and the rest of the internal RAM to data memory. Figure 22 shows the program memory and the data memory within the internal RAM.

Figure 22. Program Memory and Data Memory within the internal RAM

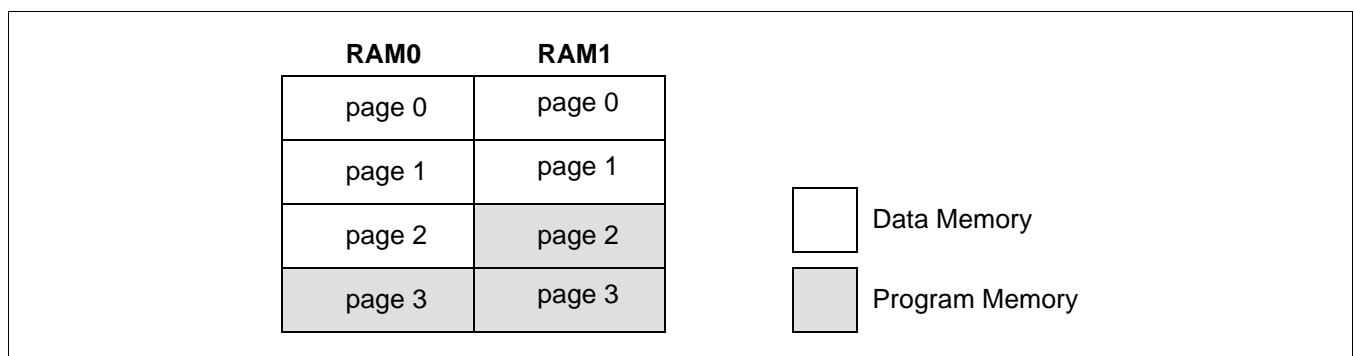

The host sends the following commands and parameters to the KD16902 for downloading and executing the user written codes.

```

0x05 ; Select Mode 5, the User Written Program
0x3E ; RAM Address, High
0x03 ;
0x3F ; RAM Address, Low
0x00 ; The first instruction is at 0x0300
0x40 ; RAM Data, High
<upper byte of the first instruction>
0x41 ; RAM Data, Low
<lower byte of the first instruction>
0x3E
0x03
0x3F
0x01 ; The second instruction is at 0x0301
0x40
<upper byte of the second instruction>
0x41
<lower byte of the second instruction>

keep download the rest of the user written codes

0x3D ; Program Memory Configuration Command
0x09 ; RAM0_CFG[1:0] - 01 & RAM1_CFG[1:0] - 10
0x42 ; Jump to Program Memory Address, High
0x12
0x43 ; Jump to Program Memory Address, Low
0x00 ; pc <- 0x1200  program address 0x1200 <=> data address 0x0300 in RAM0

```

Programming Guide

In the KD16902, the input and the output uses separate interrupts. The L/Ls/C and R/Rs/LFE samples are read from the external registers at different instances of input interrupt. The L/Ls/C samples are read first, followed by the R/Rs/LFE samples at the next interrupt. Similar to input, the L/Ls/C/Lv and R/Rs/LFE/Rv samples are written to the external registers at different instances of output interrupt. Here, the Lv and Rv denotes the left and right VCR outputs, respectively. This makes the input/output interrupt frequency twice the sampling frequency.

The KD16902 requires the user written program to synchronize with the input interrupts. To synchronize properly with the input interrupts, the user written program must wait until R/Rs/LFE samples are read before proceeding to the main program. The user written program can use an entry, labeled Flag, in data memory for this purpose. The input interrupt service routine (ISR) sets this flag to 1 after reading the R/Rs/LFE samples. The user must toggle the content of Flag back to 0 before proceeding to the main part.

Since the interrupt frequency is larger than the sampling frequency, the interrupt may occur while the user written program is in running state. The user written program must copy the content of the input buffers to its own working buffers before proceeding to the main part. Otherwise, the input ISR may change the content of the input buffer and the user's function may not work properly. Table 28 shows the input buffers which are in page 0 of RAM1. The buffers are listed in the order of ascending address.

Table 28. Input Buffers

Order	Label	Description
1	InputL	Input Buffer for upper 16 bit of left front
2	InputLSt	Input Buffer for upper 16 bit of left surround
3	InputCt	Input Buffer for upper 16 bit of center
4	InputR	Input Buffer for upper 16 bit of right front
5	InputRSt	Input Buffer for upper 16 bit of right surround
6	InputSubt	Input Buffer for upper 16 bit of LFE
7	InputLFtLow	Input Buffer for lower 8 bit of left front
8	InputLStLow	Input Buffer for lower 8 bit of left surround
9	InputCtLow	Input Buffer for lower 8 bit of center
10	InputRFtLow	Input Buffer for lower 8 bit of right front
11	InputRStLow	Input Buffer for lower 8 bit of right surround
12	InputSubtLow	Input Buffer for lower 8 bit of LFE

Example:

Following codes illustrate the proper usage of FLAG and user's working buffers. The user buffers are in the same order as the input buffers in this code.

```

        andi 00
        ld   @Flag, a

User_Wait:
        mod f, setie
        andi 00
        cmp a, @Flag
        bra z=1, @User_Wait

        andi 00
        ld   @Flag, a

        ldi  xr0, 1           # The user buffers are in page 1 of RAM0
        ldi  xr5, 0
        ldi  r0, @UserL      # The user buffers
        ldi  r5, @InputL    # The input buffers defined for the KD16902
        ldi  a, 0x0C

Read_Input:
        ld   x, (r5+!)
        ld   (r0+!), x
        sub 01
        bra z=0, @Read_Input

User_Main:
        main part of user written program

```

Similar to the inputs, the L/Ls/C/Lv and R/Rs/LFE/Rv samples are written to the external registers at different instances of output interrupt. The L/Ls/C/Lv samples are written to the external registers first followed by the R/Rs/C/Rv samples at the next interrupt. Since the KD16902 requires the user written program to be synchronized with the input interrupt, a special treatment is needed for the output. The KD16902 offers two subroutines for handling the output. The first one, *Init_OP_Buffers*, is used for initializing the output buffers. The user must include this subroutine at the beginning of the program. The second one, *Set_OP_Buffers*, returns the pointer to the output buffers. It places the beginning address of the output buffers to the register, r5. The output buffers are in page 0 of RAM1. Therefore, the user must set xr5 to 0 before calling this subroutine. The user must place this subroutine before writing output the output buffers. Table 29 shows the order of output buffers.

Table 29. Order of Output Buffers

Order	Output Buffer
1	upper 16 bit of left front
2	upper 16 bit of left surround
3	upper 16 bit of center
4	upper 16 bit of right front
5	upper 16 bit of right surround
6	upper 16 bit of LFE
7	lower 8 bit of left front
8	lower 8 bit of left surround
9	lower 8 bit of center
10	lower 8 bit of right front
11	lower 8 bit of right surround
12	lower 8 bit of LFE

Example:

Following code illustrates proper usage of output buffers:

```

        call @Init_OP_Buffers          # initialize the output buffers

        andi 00
        ld  @Flag, a

User_Wait:
        mod f, setie
        andi 00
        cmp a, @Flag
        bra z=1, @User_Wait

        andi 00
        ld  @Flag, a

        load the input from input buffers to working buffers

        main part of user written program

        ldi xr0, 1                    # The user buffers are in page 1 of RAM0
        ldi xr5, 0
        ldi r0, @UserL
        ldi a, 0x0C

        call always, @Set_OP_Buffers # get pointer to the output buffers

Write_Output:
        ld  x, (r0+)                  # r0 is pointer to the user buffers
        ld  (r5+!), x                  # r5 is pointer to the output buffers
        sub 01
        bra z=0, @Write_Output

        bra always, @User_Wait

```

4 COMMAND SET

The KD16902 provides commands for selecting mode and for providing parameters for the functions. The host sends the commands and parameters to the KD16902 through HIU, the host interface unit. The HIU only accepts data with length of a byte.

Command Usage Guide

For setting a parameter to a function, the host must send the command code identifying the parameter followed by the parameter value. Some parameters are in length of two bytes. For these parameters, the value is divided into high and low bytes because the KD16902 accepts only byte data from host. The host, first, sends the command code identifying the high byte portion of the parameter followed by the high byte data. Then, the host sends the command code for the low byte portion followed by the low byte data. The high byte must be sent first. If the order is reversed, the parameter will not set properly.

The flow chart in Figure 23 and Figure 24 shows how the KD16902 accepts commands while running a process. All the parameters sent from the host needs the End of Parameter Setting command to be in effect. The End of Parameter Setting command does not have to be sent for each parameter. The host may send several parameters before sending the End of Parameter Setting command.

Figure 23. Flow Chart during Initialization Stage

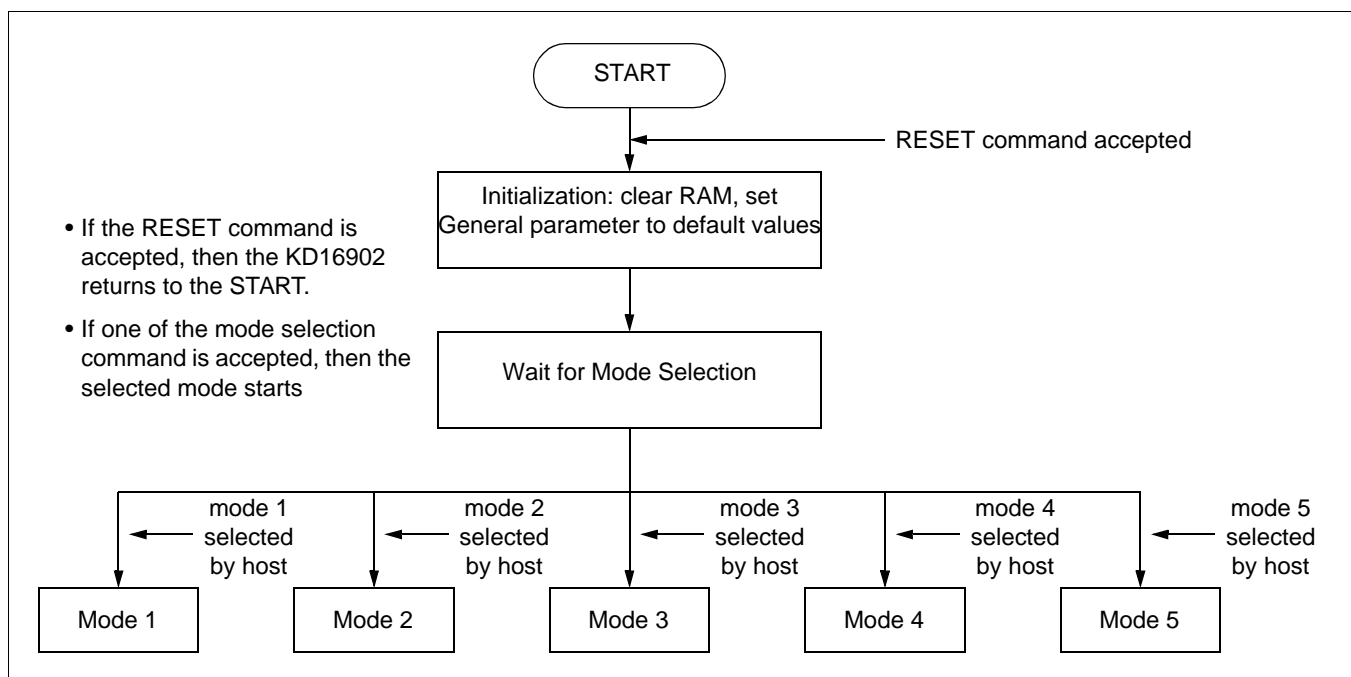
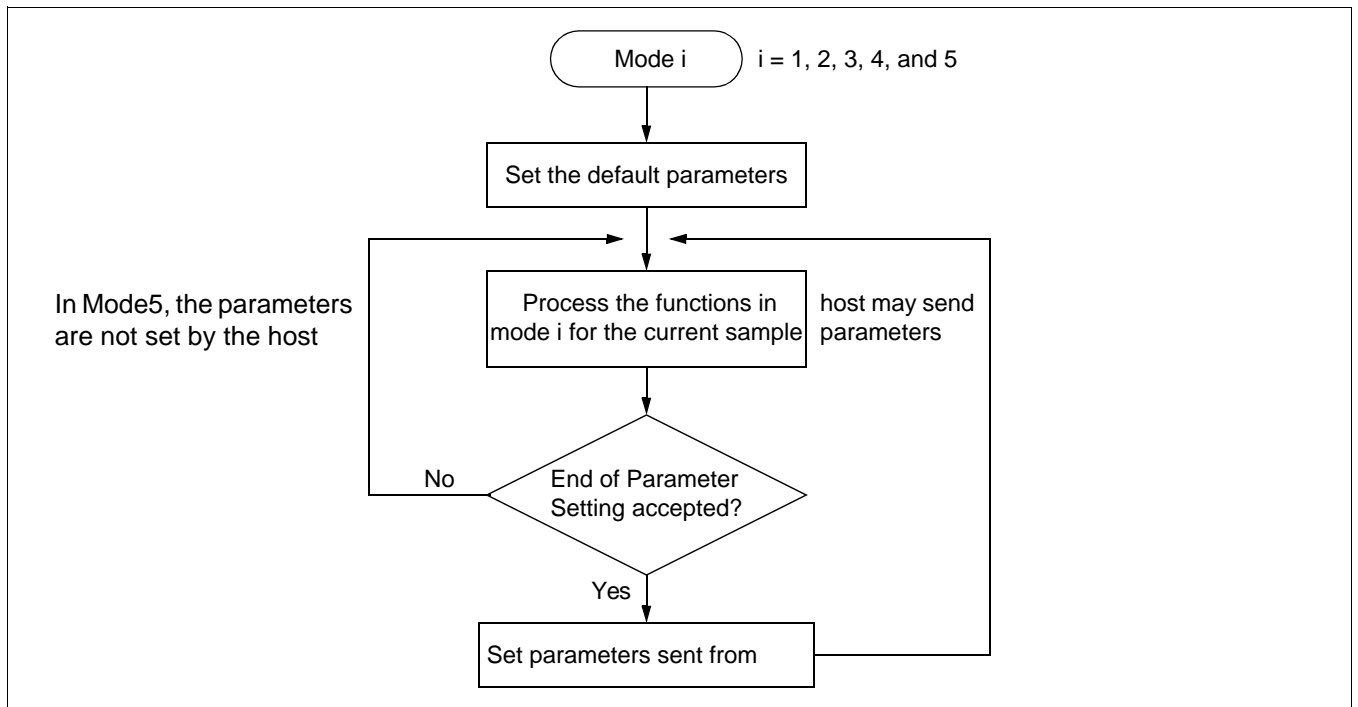

Figure 24. Flow Chart in a Mode



Example

The current mode is mode 3. The user wants to change sampling frequency and the gain of the front signal to 32 KHz and 0.5, respectively. Table shows the related commands and the new values for the parameters.

Table 30. New Parameter Values

Command	Command Code	New Parameter Value	Description
Sampling Frequency	0x0b	0x02	32 KHz
Gain of Front for Summation 1 (High)	0x1b	0x40	Upper byte of Q15 representation of 0.5
Gain of Front for Summation 1 (Low)	0x1c	0x00	Lower byte of Q15 representation of 0.5

The host send the command and parameter values to the KD16902 in the following order.

- 0x0b; sampling rate command
- 0x02; 32 KHz
- 0x1b; gain of front for summation 1 (high)
- 0x40; upper byte of the new value
- 0x1c; gain of front for summation 1 (low)
- 0x00; lower byte of the new value
- 0x05; end of parameter setting

Command Set Summary

The command set is divided into several classes. Following table describes the command classes:

Table 31. Command Classes

Command Class	Description
Mode Selection	Used for selecting a mode
General	Can be used in all modes
Downmix	Used only for Downmix function. Accepted only in mode 3
Virtual Surround	Used only for Virtual Surround function. Accepted only in modes 1, 2, and 4
Bass Redirection	Used only for Bass Redirection function. Accepted only in mode 3
Memory Configuration	Used for downloading user defined codes into internal RAM

The commands are summarized in Table 32:

Table 32. Command Set Summary

Command Name	Command Code	Command Class	Description
Mode 1	0x01	Mode Selection	Select Mode 1
Mode 2	0x02	Mode Selection	Select Mode 2
Mode 3	0x03	Mode Selection	Select Mode 3
Mode 4	0x04	Mode Selection	Select Mode 4
Mode 5	0x05	Mode Selection	Select Mode 5
End of Parameter Setting	0x06	General	Update the parameters of the current mode according to the host setting
RESET	0x07	General	Returns to waiting state. The parameters for all modes are reset to the default values
reserved	0x08	reserved	reserved
Input Channel Mode	0x09	General	Set input channel combination using the next incoming byte.
Output Channel Mode	0x0a	General	Set output channel combination using the next incoming byte
Sampling Frequency	0x0b	General	Set sampling frequency using the next incoming byte
Input Data Format	0x0c	General	Set input to 16/18/20/24 bit format and left/right justification using the next incoming byte
Output Data Format	0x0d	General	Set output to 16/18/20/24 bit format and left/right justification using the next incoming byte

Table 32. Command Set Summary

Command Name	Command Code	Command Class	Description
Input LRCC Flag	0x0e	General	The LSB of the next incoming byte is the L/R inversion flag
Bit Format	0x0f	General	Set bit format to 32 fs/48 fs/ 64 fs using the next incoming byte
Scale DM	0x10	Downmix	Next incoming byte specifies whether scale the audio signal to avoid overflow in downmix
reserved	0x11	reserved	reserved
reserved	0x12	reserved	reserved
reserved	0x13	reserved	reserved
reserved	0x14	reserved	reserved
Audible Area Control, High	0x15	Virtual Surround	Next incoming byte is the upper byte of audio area control parameter
Audible Area Control, Low	0x16	Virtual Surround	Next incoming byte is the lower byte of audio area control parameter
reserved	0x17	reserved	reserved
reserved	0x18	reserved	reserved
Filter Switches	0x19	Bass Redirection	Next incoming byte is the filter switches
LFE Redirection Switches	0x1a	Bass Redirection	Next incoming byte is the LFE redirection switches
Gain of Front for Summation 1, High	0x1b	Bass Redirection	Next incoming byte is the upper byte of gain of front for summation 1
Gain of Front for Summation 1, Low	0x1c	Bass Redirection	Next incoming byte is the lower byte of gain of front for summation 1
Gain of Rear for Summation 2, High	0x1d	Bass Redirection	Next incoming byte is the upper byte of gain of rear for summation 2
Gain of Rear for Summation 2, Low	0x1e	Bass Redirection	Next incoming byte is the lower byte of gain of rear for summation 2
Gain of Center for Summation 3, High	0x1f	Bass Redirection	Next incoming byte is the upper byte of gain of center for summation 3
Gain of Center for Summation 3, Low	0x20	Bass Redirection	Next incoming byte is the lower byte of gain of center for summation 3
Gain of Front for Summation 4, High	0x21	Bass Redirection	Next incoming byte is the upper byte of gain of front for summation 4
Gain of Front for Summation 4, Low	0x22	Bass Redirection	Next incoming byte is the lower byte of gain of front for summation 4

Table 32. Command Set Summary

Command Name	Command Code	Command Class	Description
Gain of Rear for Summation 4, High	0x23	Bass Redirection	Next incoming byte is the upper byte of gain of rear for summation 4
Gain of Rear for Summation 4, Low	0x24	Bass Redirection	Next incoming byte is the lower byte of gain of rear for summation 4
Gain of Center Summation 4, High	0x25	Bass Redirection	Next incoming byte is the upper byte of gain of center for summation 4
Gain of Center for Summation 4, Low	0x26	Bass Redirection	Next incoming byte is the lower byte of gain of center for summation 4
Gain of LPF Output for Summation 1, High	0x27	Bass Redirection	Next incoming byte is the upper byte of gain of LPF Output for summation 1
Gain of LPF Output for Summation 1, Low	0x28	Bass Redirection	Next incoming byte is the lower byte of gain of LPF Output for summation 1
Gain of LPF Output for Summation 2, High	0x29	Bass Redirection	Next incoming byte is the upper byte of gain of LPF Output for summation 2
Gain of LPF Output for Summation 2, Low	0x2a	Bass Redirection	Next incoming byte is the lower byte of gain of LPF Output for summation 2
Gain of LPF Output for Summation 3, High	0x2b	Bass Redirection	Next incoming byte is the upper byte of gain of LPF Output for summation 3
Gain of LPF Output for Summation 3, Low	0x2c	Bass Redirection	Next incoming byte is the lower byte of gain of LPF Output for summation 3
Gain of LFE for LFE Summation, High	0x2d	Bass Redirection	Next incoming byte is the upper byte of gain of LFE for LFE summation
Gain of LFE for LFE Summation, Low	0x2e	Bass Redirection	Next incoming byte is the lower byte of gain of LFE for LFE summation
Gain of Front for LFE Summation, High	0x2f	Bass Redirection	Next incoming byte is the upper byte of gain of front for LFE summation
Gain of Front for LFE Summation, Low	0x30	Bass Redirection	Next incoming byte is the lower byte of gain of front for LFE summation
Gain of Rear for LFE Summation, High	0x31	Bass Redirection	Next incoming byte is the upper byte of gain of rear for LFE summation
Gain of Rear for LFE Summation, Low	0x32	Bass Redirection	Next incoming byte is the lower byte of gain of rear for LFE summation
Gain of Center for LFE Summation, High	0x33	Bass Redirection	Next incoming byte is the upper byte of gain of center for LFE summation
Gain of Center for LFE Summation, Low	0x34	Bass Redirection	Next incoming byte is the upper byte of gain of center for LFE summation

Table 32. Command Set Summary

Command Name	Command Code	Command Class	Description
Gain of Front before Output, High	0x35	Bass Redirection	Next incoming byte is the upper byte of gain of front before output
Gain of Front before Output, Low	0x36	Bass Redirection	Next incoming byte is the lower byte of gain of front before output
Gain of Rear before Output, High	0x37	Bass Redirection	Next incoming byte is the upper byte of gain of rear before output
Gain of Rear before Output, Low	0x38	Bass Redirection	Next incoming byte is the lower byte of gain of rear before output
Gain of Center before Output, High	0x39	Bass Redirection	Next incoming byte is the upper byte of gain of center before output
Gain of Center before Output, Low	0x3a	Bass Redirection	Next incoming byte is the lower byte of gain of center before output
Gain of LFE before Output, High	0x3b	Bass Redirection	Next incoming byte is the upper byte of gain of LFE before output
Gain of LFE before Output, Low	0x3c	Bass Redirection	Next incoming byte is the lower byte of gain of LFE before output
Program Memory Configuration	0x3d	Memory Configuration	Select program RAM area, RAM0_CFG[1:0], RAM1_CFG[1:0]
RAM Address, High	0x3e	Memory Configuration	Next incoming byte is the upper byte of the data address for the user written code
RAM Address, Low	0x3f	Memory Configuration	Next incoming byte is the lower byte of the data address for the user written code
RAM Data, High	0x40	Memory Configuration	Next incoming byte is the upper byte of the user written code
RAM Data, Low	0x41	Memory Configuration	Next incoming byte is the lower byte of the user written code
Jump to Program Memory Address, High	0x42	Memory Configuration	Next incoming byte is the upper byte of the start address of the user written program
Jump to Program Memory Address, Low	0x43	Memory Configuration	Next incoming byte is the lower byte of the start address of the user written program

Command Set Description

Mode 1

Format

0	0	0	0	0	0	0	0	1
---	---	---	---	---	---	---	---	---

Command Class

Mode Selection

Description

Change current mode to mode 1.

Mode 2

Format

0	0	0	0	0	0	0	1	0
---	---	---	---	---	---	---	---	---

Command Class

Mode Selection

Description

Change current mode to mode 2.

Mode 3

Format

0	0	0	0	0	0	0	1	1
---	---	---	---	---	---	---	---	---

Command Class

Mode Selection

Description

Change current mode to mode 3.

Mode 4

Format

0	0	0	0	0	1	0	0
---	---	---	---	---	---	---	---

Command Class

Mode Selection

Description

Change current mode to mode 4.

Mode 5

Format

0	0	0	0	0	1	0	1
---	---	---	---	---	---	---	---

Command Class

Mode Selection

Description

Change current mode to mode 5.

End of Parameter Setting

Format

0	0	0	0	0	1	1	0
---	---	---	---	---	---	---	---

Command Class

General

Description

Start use the new parameters for the current mode. This command is required after setting parameters for the current running mode. The parameters for other modes cannot be set during the current mode.

RESET**Format**

0	0	0	0	0	1	1	1
---	---	---	---	---	---	---	---

Command Class

General

Description

Returns to the waiting stage for mode selection. The parameter for all modes are reset to the default values.

Input Channel Mode**Format**

0	0	0	0	1	0	0	1
---	---	---	---	---	---	---	---

Inch_Mode

Command Class

General

Description

The data following the command specifies the input channel mode and the LFE flag.

Inch_Mode[2:0] - Input Channel Mode

Inch_Mode[3] - LFE Flag, 0 for LFE On and 1 for LFE Off

Inch_Mode[7:4] - reserved

Table 33. Input Channel Mode

Inch_Mode[2:0]	Input Channel Mode	Channels
000	Not Supported	Not Supported
001	1/0	C
010	2/0	L, R
011	3/0	L, C, R
100	2/1	L, R, S
101	3/1	L, C, R, S
110	2/2	L, R, Ls, Rs
111	3/2	L, C, R, Ls, Rs

Output Channel Mode

Format

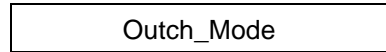
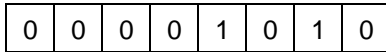

Command Class

General

Description

The data following the command specifies the output channel mode. The format used for Outch_mode[2:0] is same as that of Inch_mode[2:0]

Outch_Mode[2:0] - Output Channel Mode

Outch_Mode[7:3] - reserved

Table 34. Output Channel Mode

Outch_Mode[2:0]	Output Channel Mode	Channels
000	Not Supported	Not Supported
001	1/0	C
010	2/0	L, R
011	3/0	L, C, R
100	2/1	L, R, S
101	3/1	L, C, R, S
110	2/2	L, R, Ls, Rs
111	3/2	L, C, R, Ls, Rs

Sampling Frequency

Format

0	0	0	0	1	0	1	1
---	---	---	---	---	---	---	---

Samp_Rate

Command Class

General

Description

The data following the command specifies the sampling frequency.

Samp_Rate[1:0] - Sampling Rate

Samp_Rate[7:2] - reserved

Table 35. Sampling Rate

Samp_Rate[1:0]	Sampling Rate
00	48 KHz
01	44.1 KHz
10	32 KHz

Input Data Format

Format

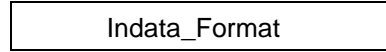
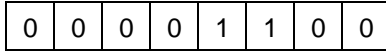

Command Class

General

Description

The data following the command specifies the input data resolution and the left/right justification

Indata_Format[1:0] - input sample resolution

Indata_Format[2] - Input data left (1) / right (0) justification

Indata_Format[7:3] - reserved

Table 36. Input Sample Resolution

Indata_Format[1:0]	Input Data Resolution
00	16 bit
01	18 bit
10	20 bit
11	24 bit

Output Data Format

Format

0	0	0	0	1	1	0	1
---	---	---	---	---	---	---	---

Outdata_Format

Command Class

General

Description

The data following the command specifies the output data resolution and the left/right justification.

Outdata_Format[1:0] - Output sample resolution

Outdata_Format[2] - Output data left (1) / right (0) justification

Outdata_Format[7:3] - reserved

Table 37. Output Sample Resolution

Outdata_Format[1:0]	Output Data Resolution
00	16 bit
01	18 bit
10	20 bit
11	24 bit

Input LRCC Flag

Format

0	0	0	0	1	1	1	0
---	---	---	---	---	---	---	---

LRCC

Command Class

General

Description

The data following this command specifies the input L/R inversion flag.

LRCC[0] - LRCC flag

LRCC[7:1] - reserved

Bit Format

Format

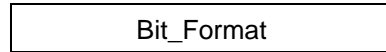
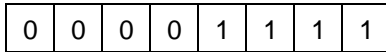

Command Class

General

Description

The parameter following this command specifies the bit format to 32 fs, 48 fs, or 64 fs

LRCC[1:0] - specifies the bit format

LRCC[7:2] - reserved

Table 38. Bit Format

Bit_Format[1:0]	Description
00	32 fs
01	48 fs
10	64 fs

Scale DM

Format

0	0	0	1	0	0	0	0
---	---	---	---	---	---	---	---

Scale_DM

Command Class

Downmix

Description

The parameter following this command specifies whether scale the audio signal to avoid overflow in downmixing. For default, the audio signal is not scaled.

Table 39. Scale_DM

Scale_DM	Description
0x00	Do not scale the audio signal. Default Value
0x01	Scale the audio signal.

Table 40. Amount of Scaling for Each Input Channel Mode

Input Channel Mode	Scaling Factor
1/0	1.0000
2/0	1.0000
3/0	0.5860
2/1	0.5860
3/1	0.4140
2/2	0.4140
3/2	0.3204

Audible Area Control, High

Format

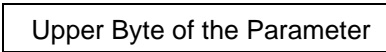
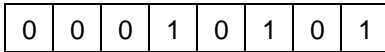

Command Class

Virtual Surround

Description

The parameter following this command is the upper byte of the audible area control parameter. The parameter controls range of audible area in which an user hears the surround effect. Please refer to Virtual Surround part of Functional Description section for more detail.

Audible Area Control, Low

Format

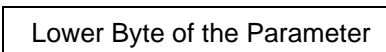
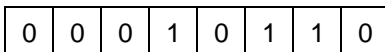

Command Class

Virtual Surround

Description

The data following this command is the lower byte of the audible area control parameter. The parameter controls range of audible area in which an user hears the surround effect. Please refer to Virtual Surround part of Functional Description section for more detail.

Filter Switches

Format

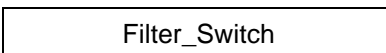
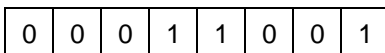

Command Class

Bass Redirection

Description

The data following this command specifies the on/off switches for filters in bass redirection function.

Filter_Switch[4:0] - [f5, f4, f3, f2, f1] Each represent On (1) / Off (0) switch for the corresponding filter.

Please refer to Figure 19 for more detail.

Filter_Switch[7:5] - reserved

LFE Redirection Switches

Format

0	0	0	1	1	0	1	0
---	---	---	---	---	---	---	---

LFE_Redir

Command Class

Bass Redirection

Description

The data following this command specifies the switches for LFE redirection before output.

LFE_Redir[3:0] - [s4, s3, s2, s1] Please refer to Figure 19 for more detail.

LFE_Redir[7:3] - reserved

Table 41. LFE Redirection Switch

LFE Redirection Switch	Description
LFE_Redir[0], s1	Redirect the LFE signal to front channel before output
LFE_Redir[1], s2	Redirect the LFE signal to rear channel before output
LFE_Redir[2], s3	Redirect the LFE signal to center channel before output
LFE_Redir[3], s4	On/Off switch for LFE output

Gain of Front for Summation 1, High

Format

0	0	0	1	1	0	1	1
---	---	---	---	---	---	---	---

Upper Byte of the Parameter

Command Class

Bass Redirection

Description

The parameter following this command is the upper byte of the gain applied to the front signals before summation 1. Please refer to Bass Redirection part of Functional Description section for more detail.

Gain of Front for Summation 1, Low

Format

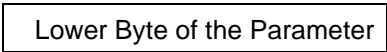
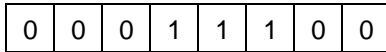

Command Class

Bass Redirection

Description

The parameter following this command is the lower byte of the gain applied to the front signals before summation 1. Please refer to Bass Redirection part of Functional Description section for more detail.

Gain of Rear for Summation 2, High

Format

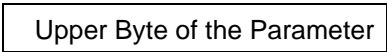
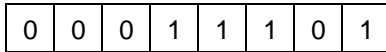

Command Class

Bass Redirection

Description

The parameter following this command is the upper byte of the gain applied to the rear signals before summation 2. Please refer to Bass Redirection part of Functional Description section for more detail.

Gain of Rear for Summation 2, Low

Format

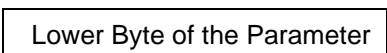
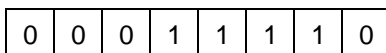

Command Class

Bass Redirection

Description

The parameter following this command is the lower byte of the gain applied to the rear signals before summation 2. Please refer to Bass Redirection part of Functional Description section for more detail.

Gain of Center for Summation 3, High

Format

0	0	0	1	1	1	1	1
---	---	---	---	---	---	---	---

Upper Byte of the Parameter

Command Class

Bass Redirection

Description

The parameter following this command is the upper byte of the gain applied to the center signal before summation 3. Please refer to Bass Redirection part of Functional Description section for more detail.

Gain of Center for Summation 3, Low

Format

0	0	1	0	0	0	0	0
---	---	---	---	---	---	---	---

Lower Byte of the Parameter

Command Class

Bass Redirection

Description

The parameter following this command is the lower byte of the gain applied to the center signal before summation 3. Please refer to Bass Redirection part of Functional Description section for more detail.

Gain of Front for Summation 4, High

Format

0	0	1	0	0	0	0	1
---	---	---	---	---	---	---	---

Upper Byte of the Parameter

Command Class

Bass Redirection

Description

The parameter following this command is the upper byte of the gain applied to the front signals before summation 4. Please refer to Bass Redirection part of Functional Description section for more detail.

Gain of Front for Summation 4, Low

Format

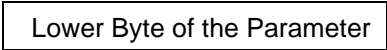
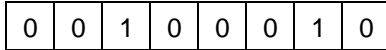

Command Class

Bass Redirection

Description

The parameter following this command is the lower byte of the gain applied to the front signals before summation 4. Please refer to Bass Redirection part of Functional Description section for more detail.

Gain of Rear for Summation 4, High

Format

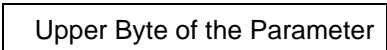
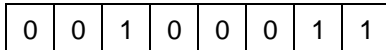

Command Class

Bass Redirection

Description

The parameter following this command is the upper byte of the gain applied to the rear signals before summation 4. Please refer to Bass Redirection part of Functional Description section for more detail.

Gain of Rear for Summation 4, Low

Format

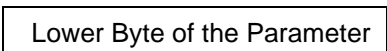
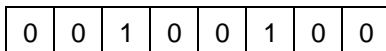

Command Class

Bass Redirection

Description

The parameter following this command is the lower byte of the gain applied to the rear signals before summation 4. Please refer to Bass Redirection part of Functional Description section for more detail.

Gain of Center for Summation 4, High

Format

0	0	1	0	0	1	0	1
---	---	---	---	---	---	---	---

Upper Byte of the Parameter

Command Class

Bass Redirection

Description

The parameter following this command is the upper byte of the gain applied to the center signal before summation 4. Please refer to Bass Redirection part of Functional Description section for more detail.

Gain of Center for Summation 4, Low

Format

0	0	1	0	0	1	1	0
---	---	---	---	---	---	---	---

Lower Byte of the Parameter

Command Class

Bass Redirection

Description

The parameter following this command is the lower byte of the gain applied to the center signal before summation 4. Please refer to Bass Redirection part of Functional Description section for more detail.

Gain of LPF Output for Summation 1, High

Format

0	0	1	0	0	1	1	1
---	---	---	---	---	---	---	---

Upper Byte of the Parameter

Command Class

Bass Redirection

Description

The parameter following this command is the upper byte of the gain applied to the LPF output before summation 1. Please refer to Bass Redirection part of Functional Description section for more detail.

Gain of LPF Output for Summation 1, Low

Format

0	0	1	0	1	0	0	0
---	---	---	---	---	---	---	---

Lower Byte of the Parameter

Command Class

Bass Redirection

Description

The parameter following this command is the lower byte of the gain applied to the LPF output before summation 1. Please refer to Bass Redirection part of Functional Description section for more detail.

Gain of LPF Output for Summation 2, High

Format

0	0	1	0	1	0	0	1
---	---	---	---	---	---	---	---

Upper Byte of the Parameter

Command Class

Bass Redirection

Description

The parameter following this command is the upper byte of the gain applied to the LPF output before summation 2. Please refer to Bass Redirection part of Functional Description section for more detail.

Gain of LPF Output for Summation 2, Low

Format

0	0	1	0	1	0	1	0
---	---	---	---	---	---	---	---

Lower Byte of the Parameter

Command Class

Bass Redirection

Description

The parameter following this command is the lower byte of the gain applied to the LPF output before summation 2. Please refer to Bass Redirection part of Functional Description section for more detail.

Gain of LPF Output for Summation 3, High

Format

0	0	1	0	1	0	1	1
---	---	---	---	---	---	---	---

Upper Byte of the Parameter

Command Class

Bass Redirection

Description

The parameter following this command is the upper byte of the gain applied to the LPF output before summation 3. Please refer to Bass Redirection part of Functional Description section for more detail.

Gain of LPF Output for Summation 3, Low

Format

0	0	1	0	1	1	0	0
---	---	---	---	---	---	---	---

Lower Byte of the Parameter

Command Class

Bass Redirection

Description

The parameter following this command is the lower byte of the gain applied to the LPF output before summation 3. Please refer to Bass Redirection part of Functional Description section for more detail.

Gain of LFE for LFE Summation, High

Format

0	0	1	0	1	1	0	1
---	---	---	---	---	---	---	---

Upper Byte of the Parameter

Command Class

Bass Redirection

Description

The parameter following this command is the upper byte of the gain applied to the LFE signal before LFE summation. Please refer to Bass Redirection part of Functional Description section for more detail.

Gain of LFE for LFE Summation, Low

Format

0	0	1	0	1	1	1	0
---	---	---	---	---	---	---	---

Lower Byte of the Parameter

Command Class

Bass Redirection

Description

The parameter following this command is the lower byte of the gain applied to the LFE signal before LFE summation. Please refer to Bass Redirection part of Functional Description section for more detail.

Gain of Front for LFE Summation, High

Format

0	0	1	0	1	1	1	1
---	---	---	---	---	---	---	---

Upper Byte of the Parameter

Command Class

Bass Redirection

Description

The parameter following this command is the upper byte of the gain applied to the front signals before LFE summation. Please refer to Bass Redirection part of Functional Description section for more detail.

Gain of Front for LFE Summation, Low

Format

0	0	1	1	0	0	0	0
---	---	---	---	---	---	---	---

Lower Byte of the Parameter

Command Class

Bass Redirection

Description

The parameter following this command is the lower byte of the gain applied to the front signals before LFE summation. Please refer to Bass Redirection part of Functional Description section for more detail.

Gain of Rear for LFE Summation, High

Format

0	0	1	1	0	0	0	1
---	---	---	---	---	---	---	---

Upper Byte of the Parameter

Command Class

Bass Redirection

Description

The parameter following this command is the upper byte of the gain applied to the rear signals before LFE summation. Please refer to Bass Redirection part of Functional Description section for more detail.

Gain of Rear for LFE Summation, Low

Format

0	0	1	1	0	0	1	0
---	---	---	---	---	---	---	---

Lower Byte of the Parameter

Command Class

Bass Redirection

Description

The parameter following this command is the lower byte of the gain applied to the rear signals before LFE summation. Please refer to Bass Redirection part of Functional Description section for more detail.

Gain of Center for LFE Summation, High

Format

0	0	1	1	0	0	1	1
---	---	---	---	---	---	---	---

Upper Byte of the Parameter

Command Class

Bass Redirection

Description

The parameter following this command is the upper byte of the gain applied to the center signal before LFE summation. Please refer to Bass Redirection part of Functional Description section for more detail.

Gain of Center for LFE Summation, Low

Format

0	0	1	1	0	1	0	0
---	---	---	---	---	---	---	---

Lower Byte of the Parameter

Command Class

Bass Redirection

Description

The parameter following this command is the lower byte of the gain applied to the center signal before LFE summation. Please refer to Bass Redirection part of Functional Description section for more detail.

Gain of Front before Output, High

Format

0	0	1	1	0	1	0	1
---	---	---	---	---	---	---	---

Upper Byte of the Parameter

Command Class

Bass Redirection

Description

The parameter following this command is the upper byte of the gain applied to the front signals before output. Please refer to Bass Redirection part of Functional Description section for more detail.

Gain of Front before Output, Low

Format

0	0	1	1	0	1	1	0
---	---	---	---	---	---	---	---

Lower Byte of the Parameter

Command Class

Bass Redirection

Description

The parameter following this command is the lower byte of the gain applied to the front before output. Please refer to Bass Redirection part of Functional Description section for more detail.

Gain of Rear before Output, High

Format

0	0	1	1	0	1	1	1
---	---	---	---	---	---	---	---

Upper Byte of the Parameter

Command Class

Bass Redirection

Description

The parameter following this command is the upper byte of the gain applied to the rear signals before output. Please refer to Bass Redirection part of Functional Description section for more detail.

Gain of Rear before Output, Low

Format

0	0	1	1	1	0	0	0
---	---	---	---	---	---	---	---

Lower Byte of the Parameter

Command Class

Bass Redirection

Description

The parameter following this command is the lower byte of the gain applied to the rear signals before output. Please refer to Bass Redirection part of Functional Description section for more detail.

Gain of Center before Output, High

Format

0	0	1	1	1	0	0	1
---	---	---	---	---	---	---	---

Upper Byte of the Parameter

Command Class

Bass Redirection

Description

The parameter following this command is the upper byte of the gain applied to the center signal before output. Please refer to Bass Redirection part of Functional Description section for more detail.

Gain of Center before Output, Low

Format

0	0	1	1	1	0	1	0
---	---	---	---	---	---	---	---

Lower Byte of the Parameter

Command Class

Bass Redirection

Description

The parameter following this command is the lower byte of the gain applied to the center signal before output. Please refer to Bass Redirection part of Functional Description section for more detail.

Gain of LFE before Output, High

Format

0	0	1	1	1	0	1	1
---	---	---	---	---	---	---	---

Upper Byte of the Parameter

Command Class

Bass Redirection

Description

The parameter following this command is the upper byte of the gain applied to the LFE signal before output. Please refer to Bass Redirection part of Functional Description section for more detail.

Gain of LFE before Output, Low

Format

0	0	1	1	1	1	0	0
---	---	---	---	---	---	---	---

Lower Byte of the Parameter

Command Class

Bass Redirection

Description

The parameter following this command is the lower byte of the gain applied to the LFE signal before output. Please refer to Bass Redirection part of Functional Description section for more detail.

Program Memory Configuration

Format

0	0	1	1	1	1	0	1
---	---	---	---	---	---	---	---

RAM_Config

Command Class

Memory Configuration

Description

Configure internal RAM into data memory and program memory. Each bank is divided into data memory and program memory according to the parameter following the command.

RAM_Config[1:0] - Used for configuring RAM0

RAM_Config[3:2] - Used for configuring RAM1

Table 42. Memory Configuration for RAM0 using RAM_Config[1:0]

RAM_Config[1:0]	Data Memory	Program Memory
00	pages 0, 1, 2, and 3	-
01	pages 0, 1, and 2	page 3
10	pages 0 and 1	pages 2 and 3
11	page 0	pages 1, 2, and 3

Table 43. Memory Configuration for RAM1 using RAM_Config[3:2]

RAM_Config[3:2]	Data Memory	Program Memory
00	pages 0, 1, 2, 3	-
01	pages 0, 1, and 2	page 3
10	pages 0 and 1	pages 2 and 3
11	page 0	pages 1, 2, and 3

RAM Address, High

Format

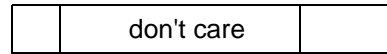
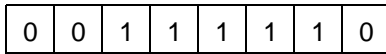

└─ 0: RAM0
 └─ 1: RAM1

└─ bits 9 and 8 of the address

Command Class

Memory Configuration

Description

The parameter following this command is used for constructing address of user written code. Its bit 1 and bit 0 is the two most significant bits of the address. The data address, which is in 10 bits, is used for downloading. The bit 7 is used for selecting the bank. After receiving the complete address and the code, the KD16902 downloads the user written code into the internal RAM at the address.

RAM Address, Low

Format

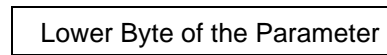
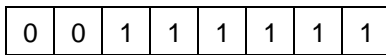

Command Class

Memory Configuration

Description

The parameter following this command contains the lower 8 bits of the address of an user written code. The data address, which is in 10 bits, is used for downloading. After receiving the code, the KD16902 downloads the user written code into the internal RAM at the address.

RAM Data, High

Format

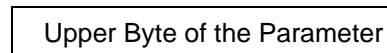
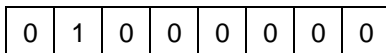

Command Class

Memory Configuration

Description

The parameter following the code is the upper byte of the user written code which is to be downloaded. The user written code is downloaded into the internal RAM at the address defined by RAM Address, High and RAM Address, Low.

RAM Data, Low

Format

0	1	0	0	0	0	0	0	1
---	---	---	---	---	---	---	---	---

Lower Byte of the Parameter

Command Class

Memory Configuration

Description

The parameter following the code is the lower byte of the user written code which is to be downloaded. The user written code is downloaded into the internal RAM at the address defined by RAM Address, High and RAM Address, Low.

Jump to Program Memory Address, High

Format

0	1	0	0	0	0	0	1	0
---	---	---	---	---	---	---	---	---

Upper Byte of the Parameter

Command Class

Memory Configuration

Description

The parameter following the code is the upper byte of the starting address of the user written codes. The address is program address. After constructing the address with the lower byte part, the KD16902 loads the starting address into pc. Then, the KD16902 starts execute the user written program.

Jump to Program Memory Address, Low

Format

0	1	0	0	0	0	0	1	1
---	---	---	---	---	---	---	---	---

Lower Byte of the Parameter

Command Class

Memory Configuration

Description

The parameter following the code is the lower byte of the starting address of the user written codes. The address is program address. After constructing the address with the lower byte part, the KD16902 loads the starting address into pc. Then, the KD16902 starts execute the user written program.

5 ELECTRICAL CHARACTERISTICS

Table 44. Absolute Maximum Ratings

Characteristics	Symbol	Value	Unit
DC Supply Voltage	V_{DD}	- 0.3 to 7.0	V
Input / Output Voltage	V_I / V_O	-0.3 to $V_{DD} + 0.3$	V
Storage Temperature	T_{STG}	Plastic; -40 to + 125	°C

Table 45. Recommended Operating Conditions

Characteristics	Symbol	Value	Unit
DC Supply Voltage	V_{DD}	Commercial; 4.75 to 5.25	V
Input / Output Voltage	V_I / V_O	0 to V_{DD}	V
Operating Temperature	T_{OPR}	Commercial; 0 to 70	°C

Table 46. DC Characteristics ($V_{DD}=4.75$ to $5.25(V)$, $T_a=25(^{\circ}C)$)

Characteristics	Symbol	Condition	Min	Type	Max	Unit
Input Voltage High	V_{IH}	CMOS	.7 V_{DD}	-	-	V
Input Voltage Low	V_{IL}	CMOS	-	-	.3 V_{DD}	V
Output Voltage High	V_{OH}	$I_{OH} = -1$ mA	2.4	-	-	V
Output Voltage Low	V_{OL}	$I_{OL} = 1$ mA	-	-	0.4	V
Operating Current	I_{DD}	X1=16.9MHz	-	-	200	mA

Figure 25. System Clock and Reset Pulse Timing

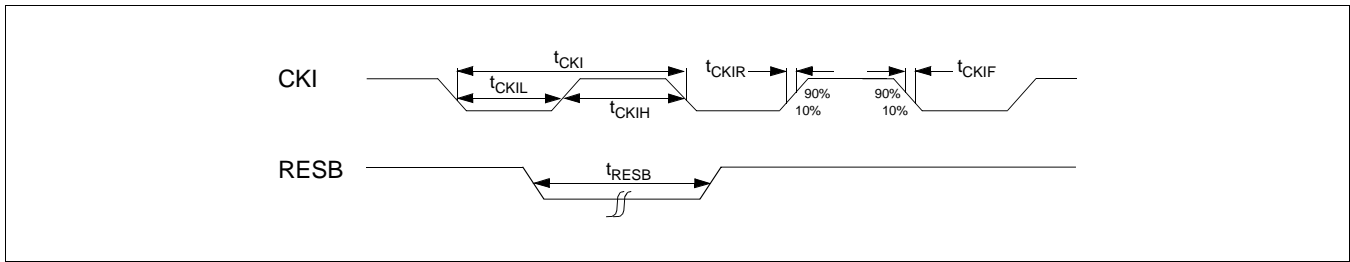

Table 47. System Clock and Reset Pulse Characteristics

AC Characteristics	Symbol	min	typ	max
System Clock Width	t_{CKI}	33.87MHz±50ppm		
System Clock Pulse Width High	t_{CKIH}	0.45* t_{CKI}	-	0.55* t_{CKI}
System Clock Pulse Width Low	t_{CKIL}	0.45* t_{CKI}	-	0.55* t_{CKI}
System Clock Rise and Fall Time	t_{CKIR} , t_{CKIF}	-	3ns	-
Reset Pulse Width Low during normal operation	t_{RESB}	100ns	-	-
Reset Pulse Width Low after system POWER-ON		1ms	-	-

Figure 26. Serial Host Interface Timing

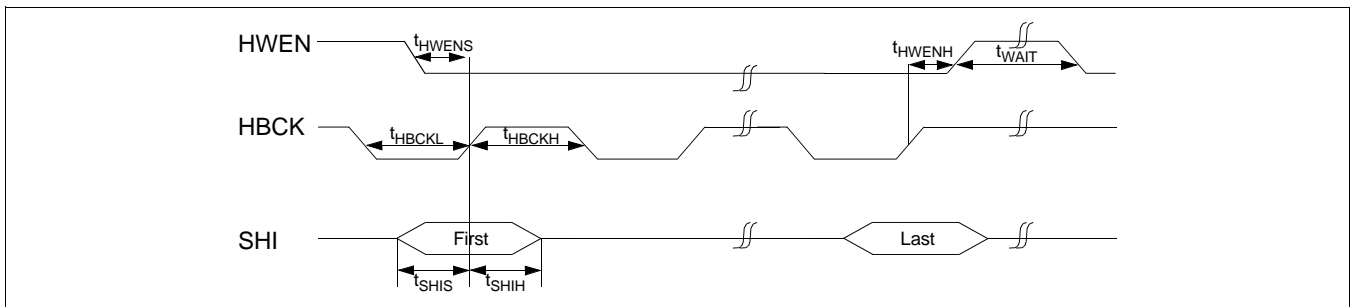

Table 48. Serial Host Interface Characteristics

AC Characteristics	Symbol	min	typ	max
HWEN Setup to First HBCK Edge	t_{HWENS}	10 ns	-	-
HWEN Hold to Last HBCK Edge	t_{HWENH}	10 ns	-	-
HBCK Pulse Width High	t_{HBCKH}	50 ns	-	-
HBCK Pulse Width Low	t_{HBCKL}	50 ns	-	-
SHI Input Set-up Time	t_{SHIS}	10 ns	-	-
SHI Input Hold Time	t_{SHIH}	10 ns	-	-
HWEN Wait Time	t_{WAIT}	1000ns	-	-

Figure 27. Serial Audio Input Timing @ IBCC=0

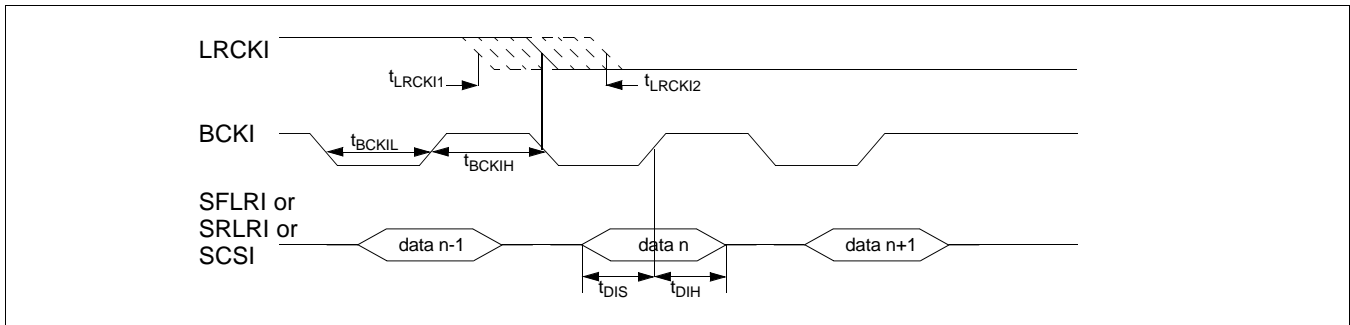

Table 49. Serial Audio Input Characteristics

AC Characteristics	Symbol	min	typ	max
BCKI Falling Edge to LRCKI Edge	t_{LRCKI1}	0 ns	-	$t_{BCKIH} - 10$ ns
	t_{LRCKI2}	0 ns	-	$t_{BCKIL} - 10$ ns
BCKI Pulse Width High	t_{BCKIH}	50 ns	-	-
BCKI Pulse Width Low	t_{BCKIL}	50 ns	-	-
Data Input Set-up Time	t_{DIS}	30 ns	-	-
Data Input Hold Time	t_{DIH}	30 ns	-	-

Figure 28. Serial Audio Output Timing @ OBCC=0

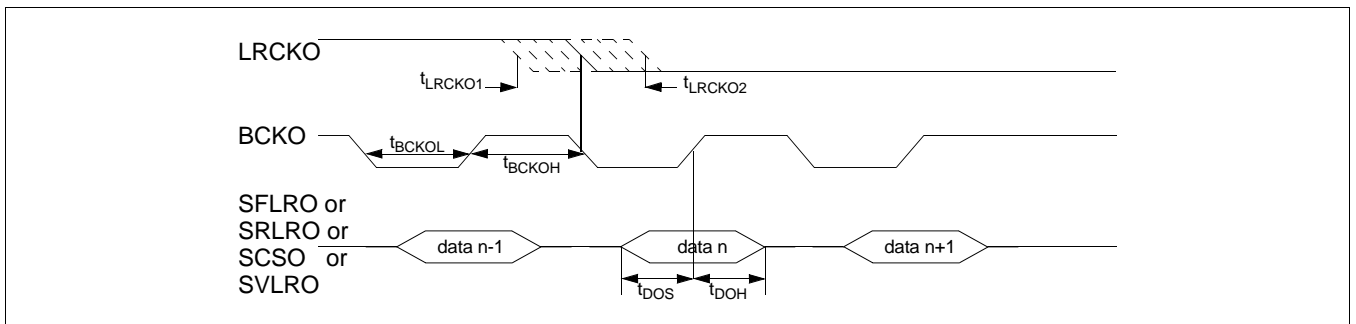

Table 50. Serial Audio Output Characteristics

AC Characteristics	Symbol	min	typ	max
BCKO Falling Edge to LRCKO Edge	t_{LRCKO1}	0 ns	-	$t_{BCKOH} - 10$ ns
	t_{LRCKO2}	0 ns	-	$t_{BCKOL} - 10$ ns
BCKO Pulse Width High	t_{BCKOH}	50 ns	-	-
BCKO Pulse Width Low	t_{BCKOL}	50 ns	-	-
Data Output Set-up Time	t_{DOS}	30 ns	-	-
Data Output Hold Time	t_{DOH}	30 ns	-	-

6 EVALUATION BOARD DIAGRAM

Figure 29. KD16902 Evaluation Board Diagram

