

QUAD OPERATIONAL AMPLIFIER

- In the Linear Mode the Input Common Mode Voltage Range Includes Ground.
- Four Internally Compensated OP Amps are in Single Package.
- Low Power Dissipation and Power Drain Suitable for Battery Operation.
- Differential Input Voltage Range Equal to the Power Supply Voltage.
- Wide Power Supply Voltage Range and Signal Power Supply : Single Supply $3V_{DC}$ to $36V_{DC}$
Dual Supplies $\pm 1.5V_{DC}$ to $\pm 18V_{DC}$.
- Large Output Voltage Swing : $0V_{DC}$ to $V_{CC}-1.5V_{DC}$.
- Low Input Biasing Current : $I_I=45nA_{DC}$ (Typ.).

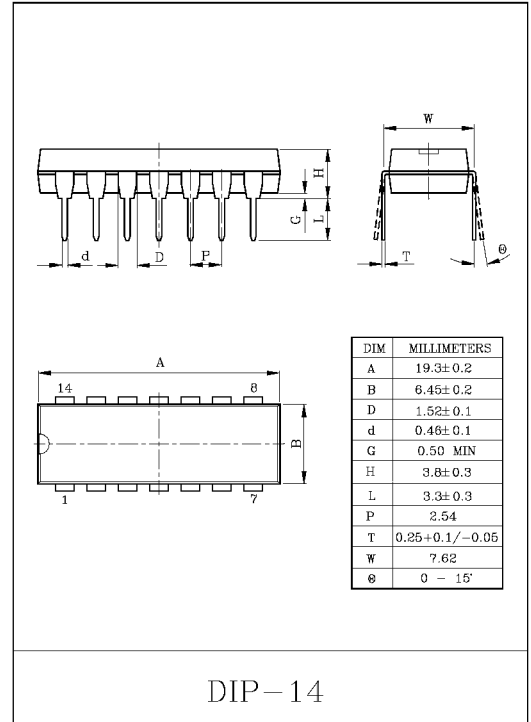

PIN CONNECTION (TOP VIEW)

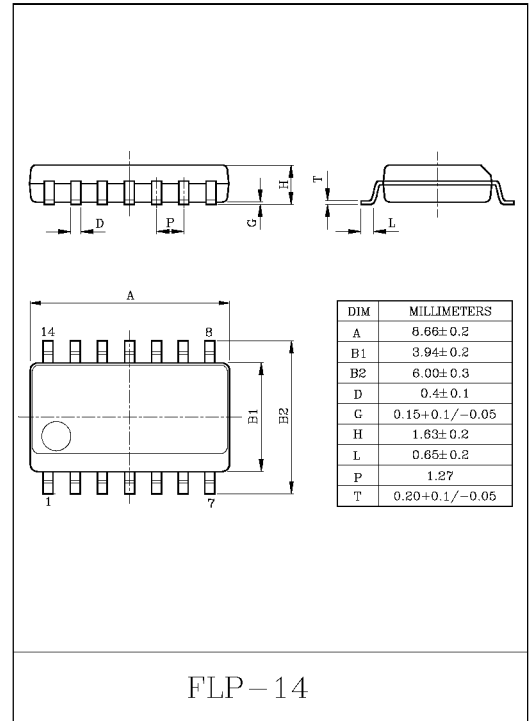
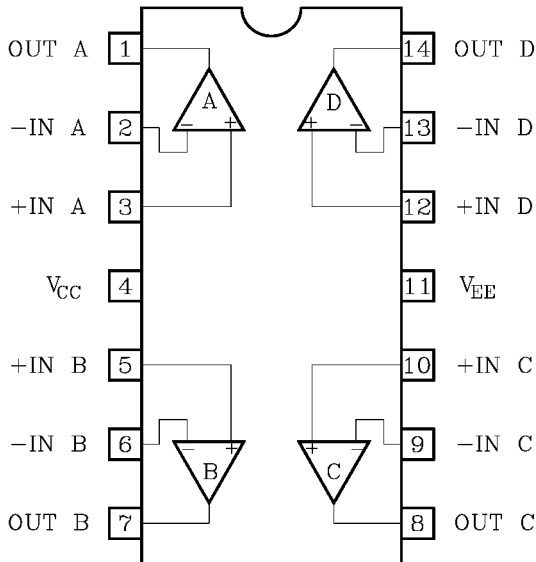

KIA324P/F

MAXIMUM RATINGS (Ta=25°C)

CHARACTERISTIC		SYMBOL	RATING	UNIT
Supply Voltage		V _{CC}	36, +18	V
		V _{EE}	0, -18	
Differential Input Voltage		DV _{IN}	±36	V
Input Voltage		V _{IN}	-0.3~36	V
Power Dissipation	KIA324P	P _D	625	mW
	KIA324F		280	
Operating Temperature		T _{opr}	-40~85	°C
Storage Temperature		T _{stg}	-55~125	°C

EQUIVALENT CIRCUIT

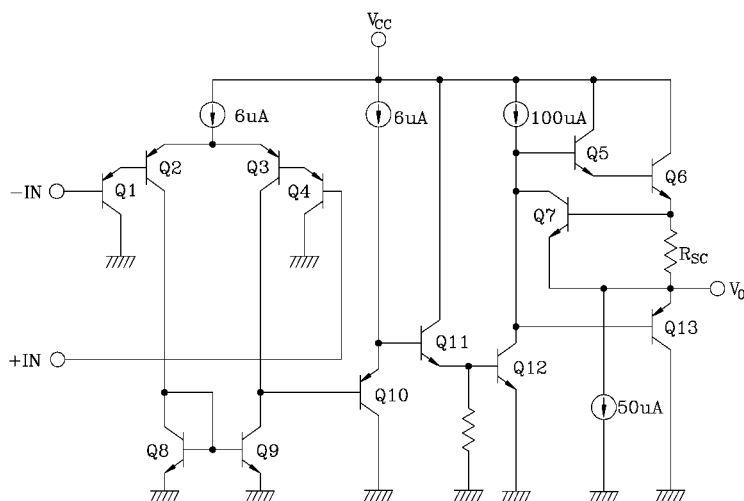

ELECTRICAL CHARACTERISTICS (V_{CC}=5V, V_{EE}=GND, Ta=25°C)

CHARACTERISTIC	SYMBOL	TEST CONDITION	MIN.	TYP.	MAX.	UNIT
Input Offset Voltage	V _{IO}	R _g ≤ 10kΩ	-	2	7	mV
Input Offset Current	I _{IO}	-	-	5	30	nA
Input Bias Current	I _I	-	-	45	150	nA
Common Mode Input Voltage	CMV _{IN}	V _{CC} =30V, V _{EE} =GND	0	V _{CC} -1.5	-	V
Supply Current	I _{CC} , I _{EE}	R _L =∞, All OP Amps	-	0.7	1.2	mA
Voltage Gain	G _V	R _L ≥ 2kΩ	86	100	-	dB
Maximum Output Voltage Swing	V _{OP-P}	R _L =2kΩ	0	V _{CC} -1.5	-	V
Common Mode Input Signal Rejection Ratio	CMRR	-	60	85	-	dB
Supply Voltage Rejection Ratio	SVRR	R _g =10kΩ	60	100	-	dB
Source Current	I _{source}	-IN=0V _{DC} , +IN=1V _{DC}	20	40	-	mA
Sink Current	I _{sink}	-IN=1V _{DC} , +IN=0V _{DC}	10	20	-	mA

KIA324P/F

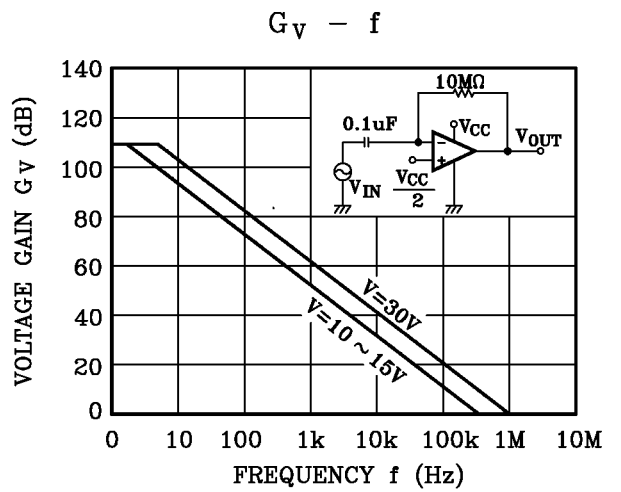
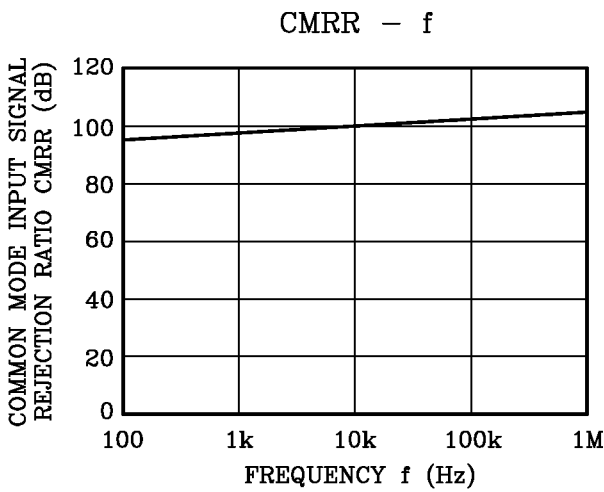
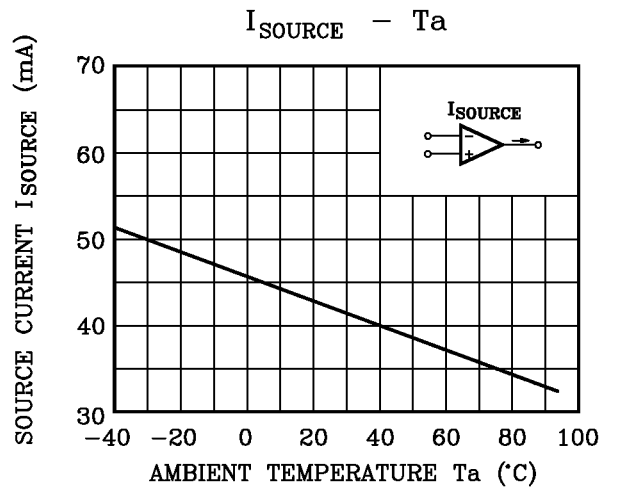
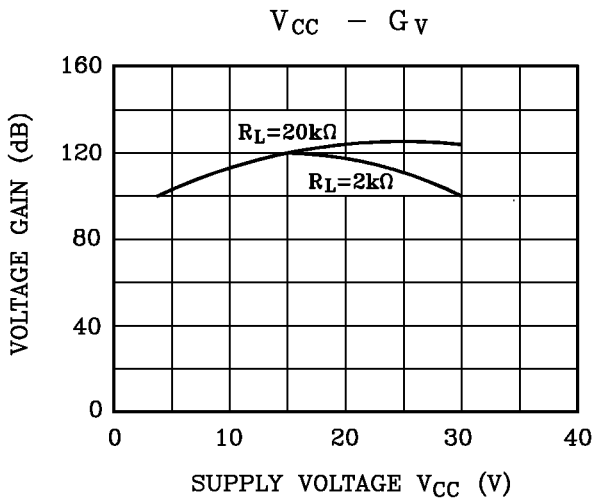
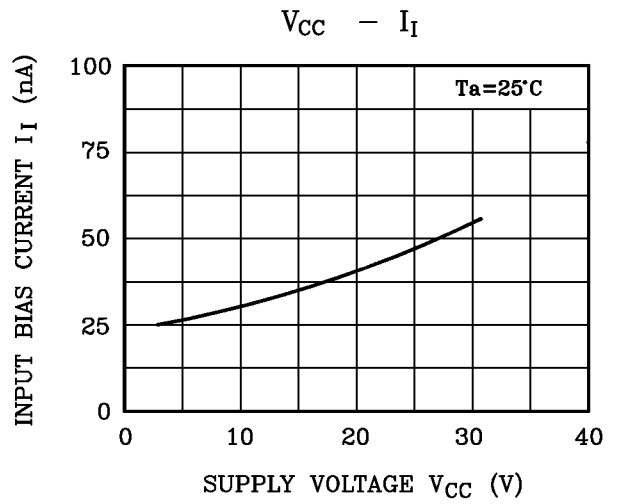
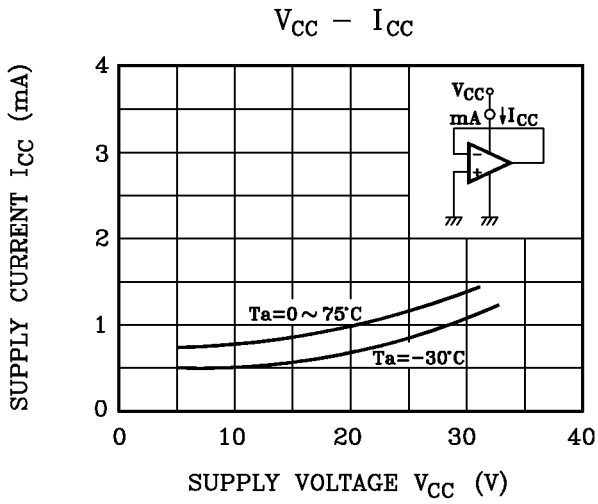

KIA324P/F

