

KT8555

TIME SLOT ASSIGNMENT CIRCUIT

INTRODUCTION

The KT8555 is a per channel Time Slot Assignment Circuit (TSAC) that produces 8-bit receive and transmit time slots for four 1 CHIP CODEC.

Each frame synchronization pulse may be independently assigned to a time slot in a frame of up to 84 time slots.

FEATURES

- | Single, 5V operation
- | Low power consumption: 5mW
- | Controls four 1 CHIP CODEC
- | Independent transmit and receive frame syncs enables
- | channel unidirectional mode
- | Up to 64 time slots per frame
- | Compatible with KT8554/7 CODECs
- | TTL and CMOS compatible

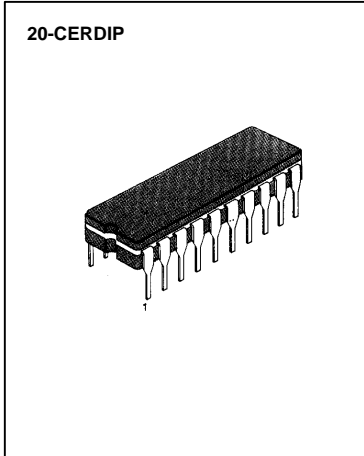

ORDERING INFORMATION

Device	Package	Operating Temperature
KT8555J	20-CERDIP	- 20°C ~ + 125°C

PIN CONFIGURATION

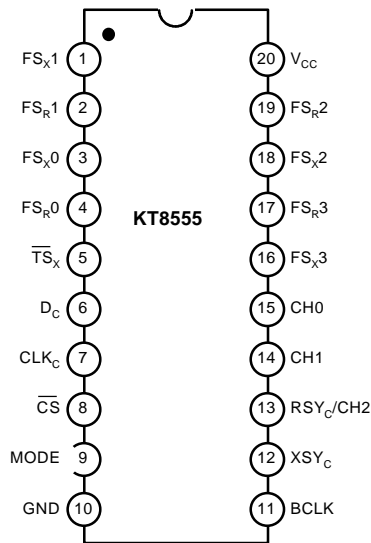

Fig. 1

PIN DESCRIPTION

Pin No	Symbol	Description
3 1 18 16	FS _X 0 FS _X 1 FS _X 2 FS _X 3	A frame sync output which is normally low, and goes active-high for 8 cycles of BCLK when a valid transmit time slot assignment is made.
4 2 19 17	FS _R 0 FS _R 1 FS _R 2 FS _R 3	A frame sync output which is normally low, and goes active-high for 8 cycles of BCLK when a valid receive time slot assignment is made.
5	\overline{TS}_X	This pin pulls low during any active transmit time slot. (N-channel open drain)
6	D _C	The input for an 8 bit serial control word. \overline{X} is the first bit clocked in.
7	CLK _C	The clock input for the control interface.
8	\overline{CS}	The active-low chip select for the control interface.
9	MODE	Mode 1 = Open or V _{CC} Mode 2 = Gnd
10	GND	Ground
11	BCLK	The bit clock input (2.048 MHz)
12	XSY _C	The transmit TSO sync pulse input. Must be synchronous with BCLK.
13	RSY _C /CH2	The transmit time slot 0 sync pulse input. Must be synchronous with BCLK. In mode 1 this input is the receive time slot 0 sync pulse, RSY _C , which must be synchronous with BCLK. In mode 2 this is the CH2 input for the MSB of the channel select word.
14	CH1	The input for the NSB (next significant bit) of the channel select word.
15	CH0	The input for the LSB (last significant bit) of the channel select word, which defines the frame sync output affected by the following control word.
20	V _{CC}	Power supply pin. 5V ±5%

ABSOLUTE MAXIMUM RATINGS (T_a = 25°C)

Characteristic	Symbol	Value	Unit
Positive Supply Voltage	V _{CC}	7.0	V
Input Voltage	V _I	V _{CC} + 0.3 ~ - 0.3	V
Output Voltage	V _O	V _{CC} + 0.3 ~ - 0.3	V
Operating Temperature Range	T _{OPR}	- 25 ~ 125	°C
Storage Temperature Range	T _{STG}	- 65 ~ 150	°C
Lead Temperature (Soldering, 10 secs)	T _{LEAD}	300	°C

ELECTRICAL CHARACTERISTICS (Unless otherwise noted; $V_{CC} = 5.0V \pm 5\%$, $T_a = 0^\circ C \sim 70^\circ C$)

Characteristic	Symbol	Test Conditions	Min	Typ	Max	Unit
Operating Current	I_{CC}	BCLK = 2.048MHz, all outputs open		1	1.5	mA
Input Voltage High	V_{IH}		2.0			V
Input Voltage Low	V_{IL}				0.7	V
Input Current 1	I_{I1}	All Inputs Except Mode, $V_{IL} < V_{IN} < V_{IH}$	-1		1	μA
Input Current 2	I_{I2}	Mode, $V_{IN} = 0V$	-100			μA
Output Voltage High	V_{OH}	FS _X and FS _R Outputs, $I_{OH} = 3mA$	2.4			V
Output Voltage Low	V_{OL}	FS _X and FS _R Outputs, $I_{OL} = 3mA$			0.4	V
		TS _X output, $I_{OL} = 3mA$			0.4	V
Rise and Fall Time of Clock	$t_{R(CK)}$ $t_{F(CK)}$	BCLK, CLK _C			50	nS
Delay to TS _X Low	$t_D(TSX L)$	$C_L = 50pF$			140	nS
Delay to TS _X High	$t_D(TSX H)$	$R_L = 1K\Omega$ to V_{CC}	30		100	nS
Hold Time from BCLK to Frame Sync	$t_H(BFS)$		50			nS
Set-Up Time from Frame Sync to BCLK	$t_H(FSB)$		30			nS
Delay Time from BCLK Low to FX _{X/R} 0-3 High or Low	t_D	$C_L = 50pF$			50	nS
Hold Time from Channel Select to CLKC	$t_H(CSC)$		50			nS
Set-Up Time from Channel Select to CLKC	$t_{SU}(CSC)$		30			nS
Period of Clock	t_{CK}	BCLK, CLK _C	240			nS
Width of Clock High	$t_W(CKH)$	BCLK, CLK _C	50			nS
Width of Clock Low	$t_W(CLK)$	BCLK, CLK _C	50			nS
Set-Up Time from D _C to CLKC	$t_{SU}(DC C)$		30			nS
Hold Time from CLKC to D _C	$t_H(CDC)$		50			nS
Set-Up Time from CS to CLKC	$t_{SU}(CC)$		30			nS
Hold Time from CLKC to CS	$t_H(CC)$		100			nS

TIMING DIAGRAM

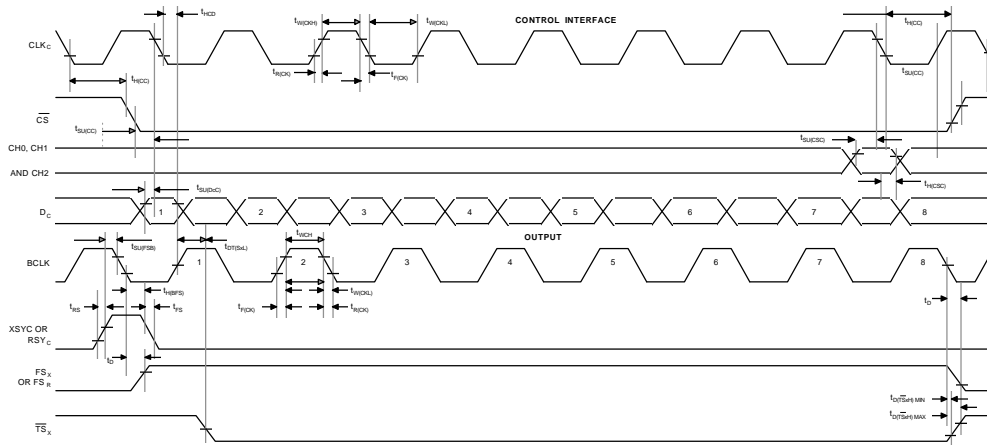

APPLICATION INFORMATION
OPERATING CONTROL MODE 1

The KT8555 is a control interface which requires an 8 bit serial control word. Either one of the frame sync output group, FS_X0 to FS_X3 or FS_R0 to FS_R3, affected by the control word is defined by the two bits, \bar{X} and \bar{R} . Time slot selected from 0 to 63 is specified. A frame sync output is highly active for one time slot which is equivalent to 8 cycles of BCLK. Up to 64 time slots are allowed to form a frame. There are two operational mode. In mode 1, each channel of transmit and receive direction has different time slot assigned. This mode can be selected by either leaving pin 9 (MODE) opened or connecting it with V_{CC}. In such a case, pin 13 is RSYC input defining the start of each receive frame while four output, FS_R0 to FS_R3, are assigned with respect to RSYC. On the other hand, start of each transmit frame is defined by XSYC input by which output FS_X0 to FS_X3, are assigned. XSYC and RSYC can be phase related. Channels from 0-3 are selected by the input CH0 and CH1 (refer to the table 1).

\bar{X}	\bar{R}	T5	T4	T3	T2	T1	T0
-----------	-----------	----	----	----	----	----	----

\bar{X} is the first bit clocked into D_C input

CH1	CH0	Channel Selected
0	0	Assign to FS _X 0 and/or FS _R 0
0	1	Assign to FS _X 1 and/or FS _R 1
1	0	Assign to FS _X 2 and/or FS _R 2
1	1	Assign to FS _X 3 and/or FS _R 3

CONTROL DATA FORMAT

T5	T4	T3	T2	T1	T1	Time Slot
0	0	0	0	0	0	0
0	0	0	0	0	1	1
0	0	0	0	1	0	2
.
.
0	1	1	1	1	0	30
0	1	1	1	1	1	31
1	0	0	0	0	0	32
1	0	0	0	0	1	33
.
.
1	1	1	1	1	1	63

\bar{X}	\bar{R}	Action
0	0	Assign time slot to both selected FS _X and FS _R
0	1	Assign time slot to selected FS _X only
1	0	Assign time slot to selected FS _R only
1	1	Disable both selected FS _X and FS _R

TABLE 1. OPERATING CONTROL MODE 1

OPERATING CONTROL MODE 2

In mode 2, all 8 frame sync outputs can be assigned with respect to XSYC input. The mode 2, selected by connecting pin 9 (MODE) to GND, enables the KT8555 TSAC suitable for an 8-channel unidirectional controller and for a system where both transmit and receive direction of each channel have same time slot assigned. For instance, FS_X and FS_R input of 1 CHIP CODEC are hard wired together. The channel assigned has its channel selected by CH0, CH1 and CH2 (refer to table 2).

CH2	CH1	CH0	Channel Selected
0	0	0	Assign to FS _X 0
0	0	1	Assign to FS _X 1
0	1	0	Assign to FS _X 2
0	1	1	Assign to FS _X 3
1	0	0	Assign to FS _R 0
1	0	1	Assign to FS _R 1
1	1	0	Assign to FS _R 2
1	1	1	Assign to FS _R 3

\bar{X}	\bar{R}	Action
0	0	Assign time slot to selected output
0	1	Assign time slot to selected output
1	0	Assign time slot to selected output
1	1	Disable both selected output

TABLE 2. OPERATING CONTROL MODE 2



APPLICATION CIRCUIT

The KT8555 TSAC combined with any kind of 1 CHIP CODEC from KT8554/7 series can obtain data timing as illustrated in Fig. 3. Even though FS_x output goes high before BCLK gets high, the D_x output of the 1 CHIP CODEC remains in the TRI-STATE mode until both outputs are high. The eight bit period is shortened to avoid PCM data clash at PCM pre-highway.

Alternatively, full 8 bits can be obtained by inverting the BCLK to the 1 CHIP CODEC devices, thereby rising edges of BCLK and FS_{x/R} are aligned.

Fig. 4 is typical timing of the control data interface.

Fig. 5 is the typical application circuit at operating control mode 2.

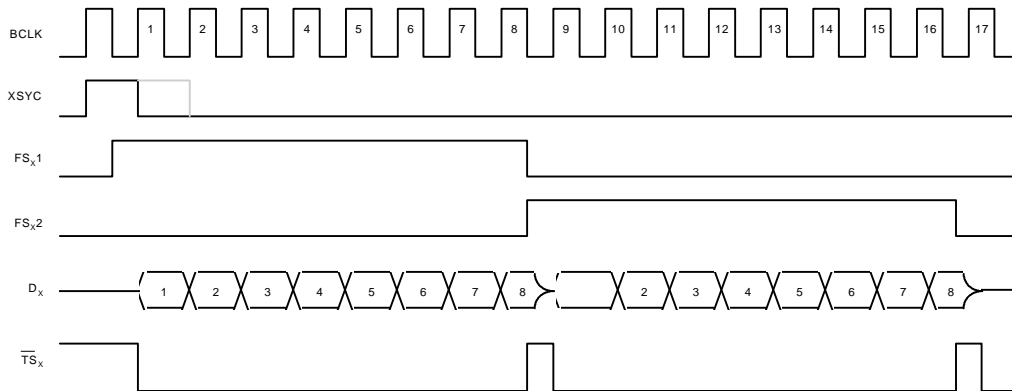

Fig. 3 Transmit Data Timing

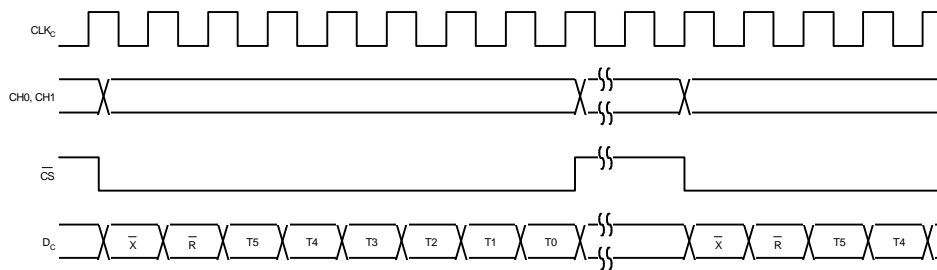
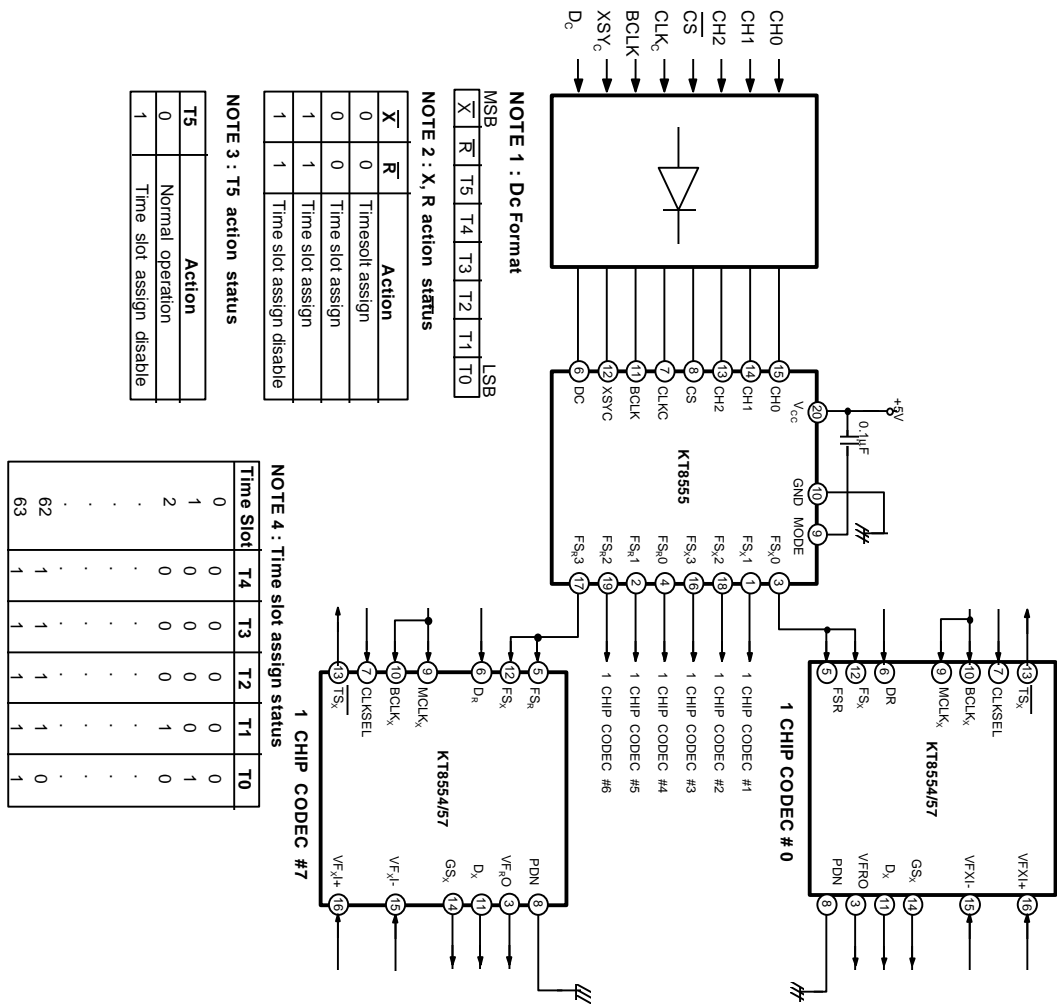

Fig. 4 Control Data Timing



NOTE 5 : Different time slot assign for RX and TX respectively also available.

Fig. 5 Digital interface on a typical subscriber linecard